

4. Project Description

Pacific Gas and Electric Company (PG&E), a regulated California utility, proposes to construct the Embarcadero-Potrero 230 kV Transmission Project (Proposed Project). The project would include construction, operation, and maintenance of a new 230 kV transmission line in San Francisco between the Embarcadero Substation, at the corner of Fremont and Folsom Streets, and the Potrero Switchyard on Illinois Street between 22nd and 23rd Streets. The new transmission line would be located primarily offshore in the San Francisco Bay, with shorter segments underground in paved city streets.

4.1 Project Title

Embarcadero-Potrero 230 kV Transmission Project
Application No. A.12-12-004

4.2 Project Sponsor's Name and Address

Pacific Gas and Electric Company
77 Beale Street, B30A
San Francisco, California 94105

4.3 Lead Agency Name and Address

California Public Utilities Commission
Energy Division
505 Van Ness Avenue, Fourth Floor
San Francisco, California 94102

4.4 Lead Agency Contact Person and Phone Number

Billie Blanchard, Project Manager
Energy Division CEQA Unit
California Public Utilities Commission
505 Van Ness Avenue, Fourth Floor
San Francisco, California 94102
(415) 703-2068
E-mail: billie.blanchard@cpuc.ca.gov

4.5 Project Location

The proposed Embarcadero-Potrero 230 kV Transmission Project would be entirely within the City and County of San Francisco (the City). The transmission line would be approximately 3.5 miles in total length, including approximately 2.5 miles to be installed offshore in the San Francisco Bay, 0.4 miles to be installed in horizontal directional drills (HDD) between onshore transition points and the bay, and approximately 0.6 miles to be installed underground in paved areas, including Spear Street and Folsom Street in San Francisco's Rincon Hill neighborhood and in 23rd Street east of Illinois Street in the Central Waterfront area.

Figure 4-1 is a map of the vicinity and Figure 4-2 illustrates the project location.

4.6 Surrounding Land Uses and Setting

The northern end of the Proposed Project would be at the existing PG&E Embarcadero Substation at the corner of Fremont and Folsom Streets in the Rincon Hill area. Underground portions of the transmission line would be in the paved right-of-way of Folsom Street and Spear Street, with the proposed northern HDD transition point in Spear Street under the San Francisco-Oakland Bay Bridge (PG&E, 2012a, Section 3.10.3.1).



Land uses along Folsom Street comprise a combination of commercial and residential uses, including apartments and condominium towers, parking lots, and the Transbay Temporary Terminal. Residential uses along Folsom Street include apartments at 333 First Street, apartments between Fremont and Beale Streets, and the Infinity Towers high-rise residential complex between Main and Spear Streets. Commercial uses include parking lots, vacant land that is part of the Transbay Redevelopment Project Area, and commercial businesses and offices.

Along Spear Street, the block between Folsom and Harrison contains the Hills Plaza on the east, a mixed-use center with residential condominiums on the top floors above restaurants, commercial offices, and retail businesses. The Hills Plaza also includes a private day care center, the Bright Horizons/Marin Day School Hills Plaza Campus. Residential land uses on Spear Street consist of apartments and condominiums, including the Infinity Towers at Spear Street and Folsom, and the street-level Harbor Lofts, live/work lofts and townhomes, at 400 Spear Street south of Harrison. The street-level Harbor Lofts would be the nearest residences at approximately 25 feet from the nearest edge of construction activity. The Bay Bridge crosses above Spear Street near the cul-de-sac at the southern end of the street, adjacent to two commercial buildings and The Embarcadero.

The proposed transmission line would enter the bay via the HDD at a point between Pier 28 and the Pier 30/32 parking complex, and would continue in a direction perpendicular to the shoreline until it becomes generally between 1,500 and 2,500 feet offshore. Turning south to parallel the shoreline from Piers 28 and 30/32, the route would continue past the marina at Pier 40, the ballpark, south past Pier 70, and return to land at the east end of 23rd Street. PG&E designed the proposed route to avoid as many underwater obstacles as possible, such as charted wrecks, abandoned piers, established cable areas, or other obstructions that had been identified during the feasibility stage of design. The marine portion of the route would not be within the north/south shipping lanes or designated anchoring areas. The route would be inland from the existing Trans Bay Cable (TBC) transmission line, which, as shown in Figure 4-2, is located on the bay floor between the City of Pittsburg and the east end of 23rd Street.

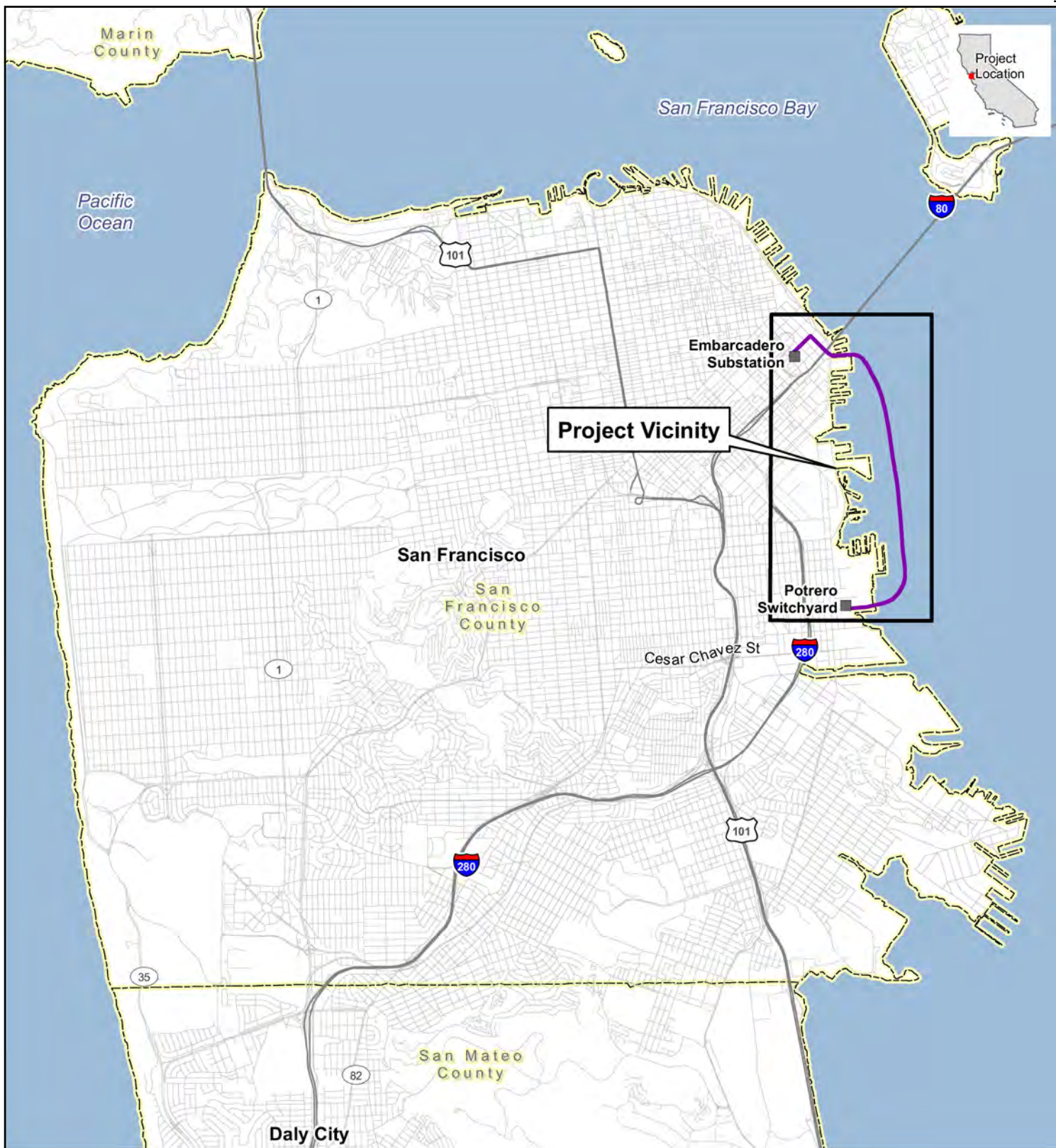
The southern end of the proposed transmission line would be at a new Potrero 230 kV Switchyard on Illinois Street between 22nd and 23rd Streets, in the Central Waterfront area. The proposed route would run under the alignment of 23rd Street to the proposed southern HDD transition point in 23rd Street east of Illinois Street. At the shoreline and on the south side of 23rd Street are a DHL facility (freight and logistics company) at 401 23rd Street, a storage facility, and the high voltage direct current (HVDC) converter station for the Trans Bay Cable. The new 230 kV Potrero Switchyard would be within the site of the former Potrero Power Plant site now owned by [NRG Potrero LLC \(formerly GenOn Energy, Inc.\)](#), on the north side of 23rd Street. The nearest residence would be about 700 feet to the west, on Third Street.



 Proposed Transmission Line
 Project Location



0 1 2
Miles



Source: PG&E, 2012.

Figure 4-1
Project Vicinity

This page intentionally blank.

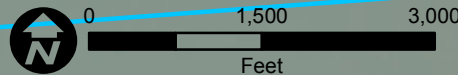
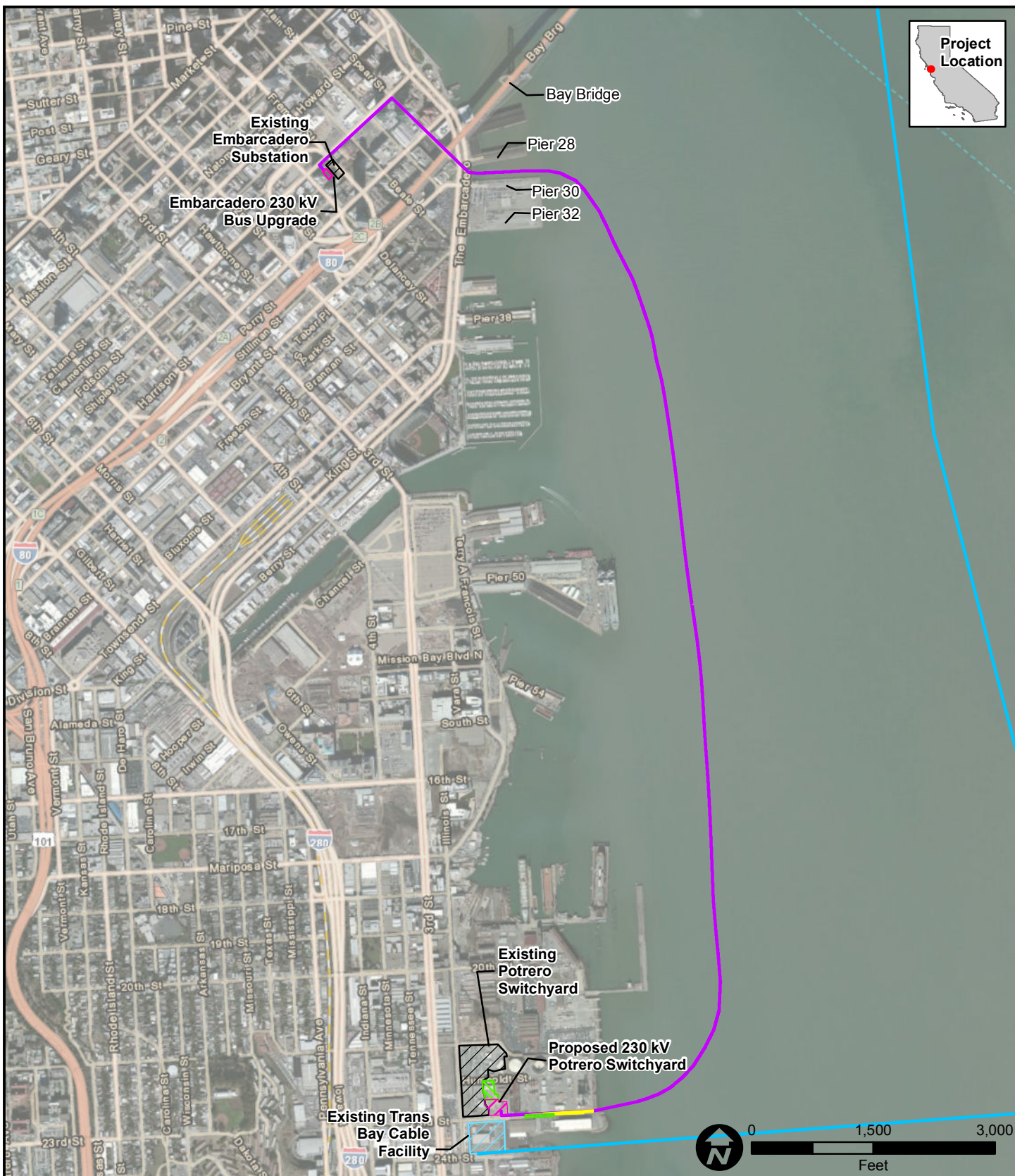







-  Proposed Embarcadero-Potrero 230 kV Project
-  Existing 400 MW Trans Bay Cable
-  Existing Substation/Switchyard
-  Proposed Substation/Switchyard
-  Proposed U/G Electric Easement
-  TCE Parcel
-  Existing Trans Bay Cable Facility

Figure 4-2
Project Location

Source: PG&E 2012, PLATTS 2010

This page intentionally blank.

4.7 General Plan Designation

The Proposed Project would be entirely within San Francisco and in the San Francisco Bay. Although the Proposed Project would not be subject to local plans and policies, this assessment considers project consistency with the federal, state, and local plans, including the San Francisco General Plan, consistent with CPUC General Order 131-D.

San Francisco General Plan, Rincon Hill Area Plan, and Central Waterfront Area Plan. The San Francisco General Plan contains ten Area Plans that set specific policies and guidelines for certain neighborhoods in the City. The Embarcadero Substation is within the Rincon Hill planning area, and the Potrero Switchyard is within the Central Waterfront planning area. Project construction within Folsom Street would also be within the Transit Center District Plan (TCDP) area and the Transbay Redevelopment Project Area.

Port of San Francisco Waterfront Land Use Plan. All submarine portions of the proposed transmission line, and portions of the proposed Potrero 230 kV Switchyard, would be within the boundary of the Port. Additionally, onshore portions east of and including the northern HDD transition in Spear Street would be within the Port's South Beach/China Basin Waterfront Subarea, adjacent to Seawall Lot 328 (SWL 328).

San Francisco Bay Conservation and Development Commission (BCDC), San Francisco Bay Plan and San Francisco Waterfront Special Area Plan. BCDC's jurisdiction includes the tidal waters of the San Francisco Bay and a 100-foot shoreline band. The submarine portion of the route would require an administrative permit from the BCDC for work within the bay and within the 100-foot shoreline band. In addition to installation of the submarine cable, a localized excavation may be made in the seafloor sediments at the HDD bore hole exit point to receive the heavy drilling fluids when the pilot hole is exited and during the pipe pulling operations. The mud captured at each HDD exit would be pumped up to a barge and disposed of per appropriate permits and regulations (see Table 4-6 in Section 4.14). Permitting by the U.S. Army Corps of Engineers (USACE) would be subject to a coastal management zone consistency determination by BCDC.

California State Lands Commission (CSLC) Jurisdictional Determination. The submarine portion of the route would be within lands that the State has legislatively granted to the City and County of San Francisco, according to a review conducted by the CSLC staff and summarized in a letter from CSLC to PG&E dated July 10, 2012. The City and County of San Francisco manages all day-to-day administration of the legislative grant; however, the CSLC has certain residual and review authority over these lands (CSLC, 2012).

4.8 Zoning

The Proposed Project would occur within the following zoning districts of the San Francisco Planning Code:

- Rincon Hill Downtown Residential Mixed Use District: includes the existing Embarcadero Substation and the Embarcadero 230 kV Bus Upgrade Project.
- TB DTR Transbay Downtown Residential District: Folsom Street between Fremont and Spear.
- RC-4 Residential-Commercial High Density: Folsom Street between Beale and Spear.
- M-1 Light Industrial: Spear Street near The Embarcadero and the proposed northern HDD transition.

- M-2 Heavy Industrial: includes the proposed Potrero 230 kV Switchyard and staging areas, and an area near The Embarcadero and the proposed northern HDD transition.
- PDR-1-G Production, Distribution & Repair Districts: areas west and south of Potrero Switchyard and proposed southern HDD transition.

4.9 Project Overview

The Proposed Project would include construction, operation, and maintenance of a new, single-circuit, 230 kV transmission line of approximately 3.5 miles between PG&E's Embarcadero Substation and Potrero Switchyard.

PG&E intends the Proposed Project to enhance the reliability of PG&E's electric service to San Francisco, and particularly to the downtown area served by the Embarcadero Substation, given the significant adverse impacts that a service outage would have on the citizens and economy of San Francisco.

The timeline for construction and testing would be approximately 22 months. During construction, building the new transmission line would require approximately 15 months of work offshore and in city streets, overlapping with 22 months of work to develop the new Potrero 230 kV Switchyard.

4.9.1 Project Objectives

PG&E states the following objectives for the Proposed Project in the CPCN application:

- 1) Improve reliability of PG&E's 230 kV transmission system in San Francisco by constructing a new 230 kV transmission line between Embarcadero Substation and Potrero Switchyard that provides a high likelihood of continued electric service to downtown San Francisco in the event of overlapping outages on both of the two existing 230 kV transmission lines running between PG&E's Martin and Embarcadero substations. Specifically:
 - (a) To increase substantially the likelihood of continued electric service to Embarcadero Substation in the event of concurrent unplanned outages of both existing 230 kV cables, such as might occur following a major seismic event.*
 - (b) To provide a high likelihood of continued electric service to Embarcadero Substation in the event of a forced outage of one existing 230 kV cable while the other existing 230 kV cable is subject to a planned outage.**
- 2) Construct an economically and technically feasible third 230 kV transmission line to PG&E's Embarcadero Substation along a route, and using construction methods and materials, that increase the likelihood that the new transmission line will remain operable following a major earthquake in the San Francisco Bay Area.*
- 3) Interconnect PG&E's San Francisco 230 kV and 115 kV transmission systems at Potrero Switchyard so that each system reinforces the other system in the event of outages or replacements of existing underground cables.*
- 4) Construct an economically and technically feasible third 230 kV transmission line to PG&E's Embarcadero Substation from Potrero Switchyard, which is the only PG&E substation on the San Francisco 115 kV network that has sufficient capacity to serve current and expected future Embarcadero loads in the event that both existing 230 kV cables into Embarcadero were out of service.*
- 5) In the long term, after the load served from Embarcadero Substation exceeds the capacity of a single existing 230 kV transmission line, improve reliability of PG&E's San Francisco 230 kV trans-*

mission system by having in place a new 230 kV transmission line to PG&E's Embarcadero Substation that will allow PG&E to maintain electric service to all customers served from Embarcadero Substation, with any one of the 230 kV transmission lines serving Embarcadero Substation subject to a planned or forced outage.

6) Construct an economically and technically feasible third 230 kV transmission line to PG&E's Embarcadero Substation before either of the two existing 230 kV transmission lines to PG&E's Embarcadero Substation must be replaced, so that downtown San Francisco is not at risk of a single-cable outage causing a prolonged loss of electric service when one of the two existing 230 kV transmission lines must be replaced.

7) Construct a third 230 kV transmission line to PG&E's Embarcadero Substation so that PG&E may allow one of the two existing 230 kV transmission lines serving Embarcadero Substation to be de-energized to allow infrastructure construction without placing downtown San Francisco at risk of a single-cable outage causing a prolonged loss of electric service.

(pp. 7-8 of PG&E, 2012a)

4.9.2 Purpose and Need

PG&E's CPCN application describes the reasons why public convenience and necessity warrant construction and operation of the proposed transmission facilities. PG&E states that the project is needed to enhance the reliability of PG&E's electric service to San Francisco, and particularly to the downtown area served by Embarcadero Substation (p. 12 of PG&E, 2012a). On March 23, 2012, the California Independent System Operator (CAISO) Governing Board approved the project as needed for reliability as part of its 2011-2012 Transmission Plan (pp. 107-108 of CAISO, 2012).

The Embarcadero Substation is a critical component of the electric transmission system serving much of downtown San Francisco, including the Financial District, Union Square, North Beach, The Embarcadero, Chinatown, Nob Hill, Telegraph Hill, and the South of Market and North of AT&T Park areas including Rincon Hill. The Embarcadero Substation is currently fed by two underground 230 kV cables from Martin Substation in Brisbane. PG&E's 115 kV system in San Francisco is supplied from Martin Substation and also by the Trans Bay Cable (TBC) connection at PG&E's Potrero Switchyard. Unlike PG&E's other San Francisco substations, Embarcadero Substation is not tied into the 115 kV transmission network, so if the two existing Martin-Embarcadero cables are out of service, only a very small number of the affected PG&E customers (representing approximately 10 MW of 305 MW of total load projected in 2016) could be served from another distribution substation. The Proposed Project would address various low-probability but very high impact scenarios under which both Martin-Embarcadero cables are out of service, causing a potentially lengthy loss of electricity in downtown San Francisco (pp. 8-9 of PG&E, 2012a).

The Proposed Project would provide a third cable into Embarcadero Substation from Potrero Switchyard rather than Martin Substation. The Proposed Project would also interconnect PG&E's 230 kV and 115 kV systems in San Francisco at Potrero (pp. 13-14 of PG&E, 2012a). Historically, the Hunters Point and Potrero Power Plants provided generation to meet local reliability needs and supply the 115 kV network. With the power plants now retired, PG&E anticipates that interconnecting the 230 kV and 115 kV systems would provide new benefits to PG&E operations and reliability, including: (a) provide the 115 kV system with an additional source of power through the existing Martin-Embarcadero 230 kV cables; (b) facilitate the eventual replacement of the 115 kV cables, some of which are now 55 to 65 years old; and (c) provide power from the 115 kV system to the 230 kV system if the 115 kV system were operational, but both TBC and the Martin-Embarcadero 230 kV cables were not (p. 11 of PG&E, 2012a).

PG&E has concluded that the Proposed Project is warranted based upon the risk of an overlapping outage of both existing Martin-Embarcadero cables; the impact that such an outage would have upon its customers in San Francisco; and the ability of the Proposed Project to mitigate the risk of outage.

The CPUC must determine during the review of the CPCN application whether the Proposed Project would serve a present or future public convenience and necessity, among other issues, subject to Pub. Util. Code § 1001 et seq. and General Order 131-D.

4.10 Project Components

PG&E proposes to interconnect the new transmission line into the upgraded 230 kV bus at Embarcadero Substation¹ and to install a new 230 kV switchyard adjacent to the existing 115 kV Potrero Switchyard. Table 4-1 provides an overview of the proposed transmission line sections.

Table 4-1. Transmission Line Sections, Approximate Length

| Transmission Line Section | Approximate Length |
|--|--------------------|
| Northern Underground Segment: Embarcadero Substation to HDD Transition Manholes on Spear Street | 0.4 mi |
| Northern HDD Segment | 0.2 mi |
| Submarine Segment at Typical Cable Burial Depth – Offshore | 2.5 mi |
| Southern HDD Segment | 0.2 mi |
| Southern Underground Segment: Potrero Switchyard to HDD Transition Manholes on 23rd Street | 0.2 mi |
| Overall Length: Embarcadero Substation to Potrero Switchyard | 3.5 mi |

Source: Table 2-1 of PG&E, 2012a.

The Proposed Project involves both transmission and substation/switchyard construction activities consisting of three major elements:

1. Construction of an approximately 3.5-mile, single-circuit 230 kV transmission line in a submarine configuration. The route would be as shown on Figure 4-2, with land-based interconnections to the Embarcadero Substation and Potrero Switchyard, as follows:
 - 0.6 miles of underground three-phase transmission line (three conductors) using 2500 thousand circular mil (kcmil) cross-linked polyethylene (XLPE) copper cable installed in a single underground duct bank with polyvinyl chloride (PVC) conduits from the substations to the landing point for the submarine cables, using open trenching;
 - 0.4 miles of transitional sections, with 2800 kcmil XLPE copper cables (1400 mm²) installed in high-density polyethylene (HDPE) conduits using HDD methods, where the submarine cables transitions from onshore to offshore; and
 - 2.5 miles of three parallel 2800 kcmil XLPE copper submarine cables laid underneath the sea floor of the San Francisco Bay.

¹ A bus is a conductor that serves as a common connection for two or more circuits within a substation. Its main purpose is to conduct electricity. See Section 4.10.2 for the Embarcadero 230 kV Bus Upgrade project.

2. Termination of the new cable into the 230 kV bus at Embarcadero Substation; see Figure 4-3. The new cable would terminate at Embarcadero Substation at either a new gas-insulated switchgear (GIS) that is under development or, if the new switchgear is delayed, the termination would occur at a modified substation bus inside the existing Embarcadero Substation.
3. Construction of a new 230 kV switchyard near the existing 115 kV Potrero Switchyard at the termination of the new cable, including interconnection of the new 230 kV switchyard and the existing 115 kV Potrero Switchyard via up to two new 230/115 kV transformers; see Figure 4-4. The new switchyard interconnects the 230 kV and 115 kV systems within the City, allowing power to flow from the 115 kV system up to the 230 kV system or from the 230 kV down to the 115 kV system, depending upon system conditions at the time. (pp. 4-6 of PG&E, 2012a)

In addition, construction would involve use of equipment staging sites, laydown yards, equipment and material storage areas, and areas to temporarily store excavated materials near the substations and land routes; see Figure 4-5 (PG&E, 2013a). Commercially available off-site office and yard space may also be used.

4.10.1 New 230 kV Transmission Line

The Proposed Project would install a new single-circuit 230 kV alternating current (AC) transmission line between Potrero Switchyard and Embarcadero Substation that is designed to continue operating following a reasonably foreseeable seismic event in the San Francisco area. PG&E's design-basis earthquake event is a moment magnitude (Mw) 7.8 earthquake on the San Andreas Fault, with a peak ground acceleration (PGA) determined at the 84th percentile motions (one standard deviation above the median). (p. 2-14 of PG&E, 2012a)

The proposed transmission line would consist of one 230 kV-rated three-phase circuit, in an underground and submarine route of 3.5 miles. On land, the three-phase circuit would be installed in a single underground duct bank; in the San Francisco Bay the circuit would be installed as three separate cables underneath the bay floor. PG&E would interconnect the new transmission line into a 230 kV bus at Embarcadero Substation and into a new 230 kV switchyard adjacent to the existing 115 kV Potrero Switchyard.

The single-circuit transmission line would use one copper extruded dielectric conductor cable per phase. The transmission line would be designed to be capable of carrying 400 megavolt-amperes (MVA) (1005 A) at the normal conductor temperature rating of 90 degrees centigrade, and up to 458 MVA (1150 A) for 48 hours under emergency conditions with a conductor temperature of 105 degrees centigrade.

Underground Cable

Two underground sections would connect the Potrero Switchyard and Embarcadero Substation to HDD transition manholes. The solid-dielectric XLPE copper conductor underground land cables would be installed in a buried reinforced concrete-encased duct bank system. The dimensions of the duct bank would be approximately 3 feet 7 inches wide by 3 feet 4 inches in height; see Figure 4-6. The trench to be excavated to install the duct bank would be slightly larger, typically approximately 4 feet 6 inches wide by 10 feet deep. At least 3 feet of cover material, or engineered fill (fluidized thermal backfill), would be placed over the top of duct bank. Installing the duct banks and vaults would require excavation and disposal of approximately 6,000 cubic yards (cy).

The three electrical cables would be contained within three 8-inch-diameter PVC conduits with one additional conduit left open as a spare for future use should a single cable fail. Fiber optic lines for sys-

tem protection and communication would be housed in two 4-inch-diameter conduits that will be installed alongside the 8-inch-diameter conduits and within the concrete duct bank. Most of the duct bank will be in a two-by-two duct configuration with potential transitions to a flat configuration to clear substructures in areas congested with other underground utilities or to fan out to the termination structures at the switchyards.

The northern underground segment between Embarcadero Substation and the northern onshore HDD transition on Spear Street would be approximately 0.4 miles. This segment would extend in a reinforced concrete duct bank northeast under Folsom Street from Embarcadero Substation to Spear Street. The route would turn southeast onto Spear Street toward the proposed northern HDD landing location near the end of Spear Street.

Under PG&E's proposed design, the northern onshore segment would have four vaults, including three at the cable landing location under or near the Bay Bridge, inside which each of the separated electrical phases of the submarine cable would be spliced to a corresponding phase (A, B or C) of the land cable. From these vaults, the three phases of the land cable would be joined in one duct bank, which would connect to a fourth vault in Folsom Street between Fremont and Main Streets.



The southern underground segment between Potrero Switchyard and the southern onshore HDD transition would be approximately 0.2 miles. The cable would exit along the southern boundary of the new Potrero 230 kV Switchyard in an underground concrete duct bank and then turn east beneath 23rd Street. The route would continue east to the southern HDD landing location, which will be located within the HDD entry pits and splice vault work zone depicted on Figure 4-9 (Potrero HDD Transition Area). There would be three vaults at the cable landing location in 23rd Street, inside which each phase of the land cable would be spliced to a corresponding, separated phase (A, B or C) of the submarine cable.

Throughout the length of the underground cable, an approximately 12-foot minimum bending radius would be maintained, and proper support and cable restraint would be applied per PG&E Underground Transmission Design Criteria (ETLS068192) and Installation Guide (ETLS072140) standards (p.2-18 of PG&E, 2012a).

The Proposed Project would generally include a minimum 11-foot burial depth for the onshore underground segments, which would both meet low-cost EMF reduction goals on the northern underground segment (See Section 4.15) and also generally allow the cable to clear all other utilities in the right-of-way, with the exception of two large storm sewers at the following locations: (1) in the intersection of Spear and Folsom; and (2) at the end of the route as it turns to enter the Embarcadero Substation. In both cases, PG&E has stated that the trench can feasibly be lowered sufficient additional depth to clear the sewer (PG&E, 2013a).

Additionally, due to utility congestion along the northern underground segment, PG&E performed a two-step analysis to establish that there would be sufficient space in Spear and Folsom Streets to install an 11-foot-deep duct bank (B&V, 2012). First, PG&E obtained preliminary as-built drawings from the San Francisco Department of Public Works based on a recent City sewer replacement and repaving project in Spear Street. PG&E also reviewed underground utility markings on Spear Street made for the City sewer project. The proposed alignment is based on these drawings and markings, and EMF policy goals (described in Section 4.15) (PG&E, 2013a); the final alignment may vary somewhat from the proposed alignment to account for the actual physical conditions encountered under the streets.



 Proposed Transmission Line
 Substation

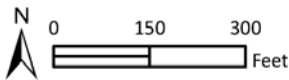

Copyright: © 2009 ESRI, i-cubed, GeoEye





Source: PG&E, 2012.

Figure 4-3
Embarcadero Substation Area

This page intentionally blank.



-  Proposed Embarcadero-Potrero 230 kV Project
-  Existing 400 MW Trans Bay Cable





-  Existing Substation/Switchyard
-  Proposed Substation/Switchyard
-  Proposed U/G Electric Easement
-  TCE Parcel
-  Existing Trans Bay Cable Facility

Figure 4-4

Potrero Switchyard Area

This page intentionally blank.

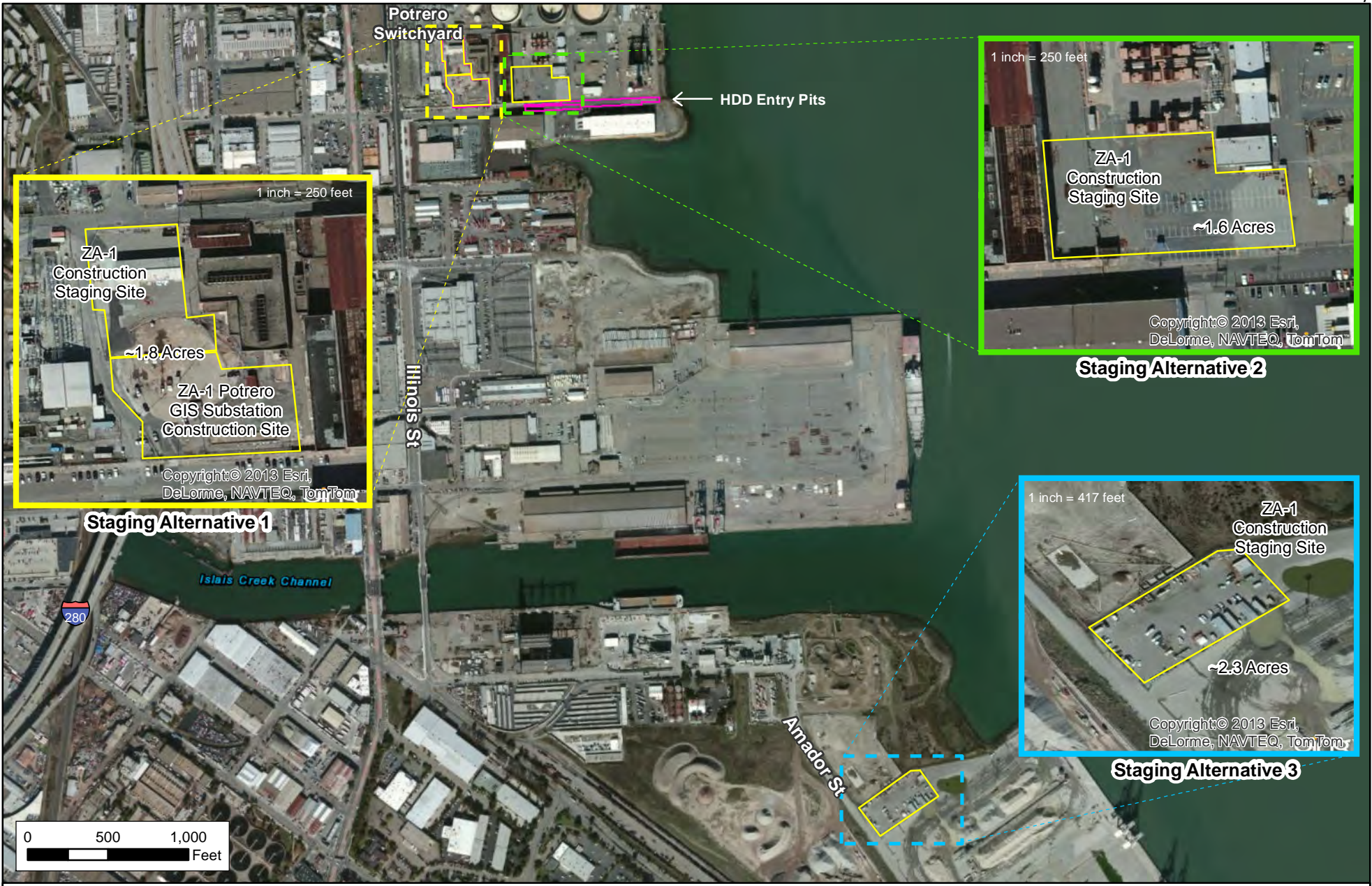

Source: PG&E, 2013.

Figure 4-5
Potential Staging Locations

This page intentionally blank.

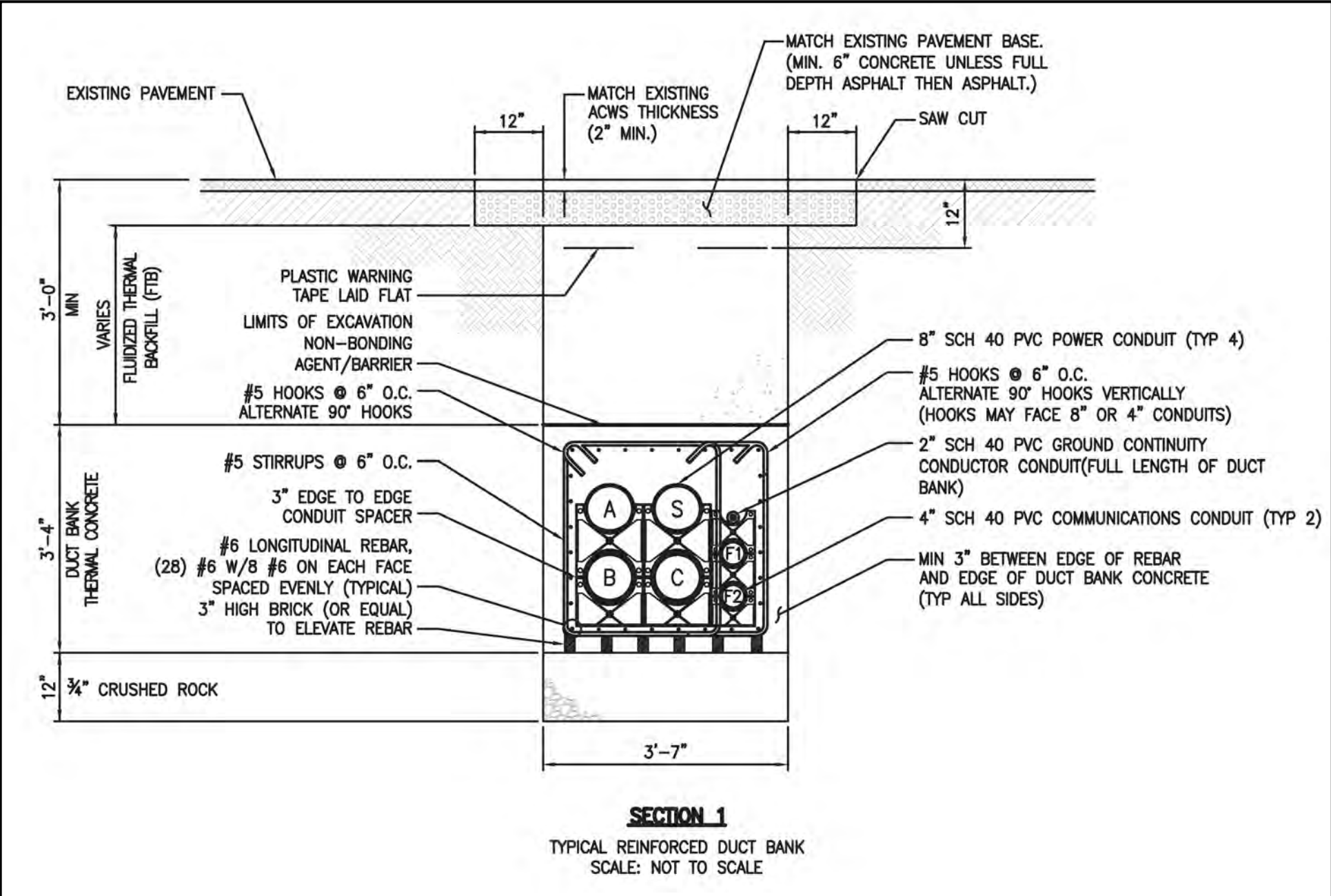

Secondly, along Folsom Street, PG&E conducted a visual survey of existing utilities as evidenced by their existing vaults. The survey concluded that the intersections of Folsom Street with Spear Street and with Main Street are crowded with utilities. However, PG&E has stated that there is enough room to install the duct bank between the existing utilities at a depth of 11 feet along the north side of Folsom Street (B&V, 2012; PG&E, 2013a).

Submarine/Underground Transition Locations

The cables would make two transitions from land to the marine environment: one on the southern end of the route on 23rd Street near Potrero Switchyard and one on the northern end of the route at Spear Street, en route to Embarcadero Substation. At each HDD transition manhole, the onshore entry pits would be up to about 5 feet wide, 8 feet long, and about 6 feet deep, requiring excavation and export of approximately 300 cy of material; see Figure 4-7.

Each transition location requires three HDD borings approximately 1,000 feet in length to extend the three phases of the submarine cable, ground cable, and communications cable from the land. Three HDDs at each transition would be spaced at approximately 10 feet apart on land and gradually flared out to form an approximately 33- to 150-foot separation under water. At each HDD transition location, the underground duct bank would split into three single-phase manholes with a vault at each of the three landing locations inside which a phase of the underground cable would be spliced to the separated electrical phases of the submarine cable.

Northern HDD Transition

The HDD rig for the northern landing would be staged in the southeastern-most block of Spear Street, directly under or near the Bay Bridge; see Figure 4-8. This block of Spear Street is a cul-de-sac with no through traffic. The northern HDD transition to the bay would be steeper than the southern HDD transition. Water depth is near 80 feet about 850 feet east of Piers 28 and 30/32 and then slopes up steeply towards the seawall, climbing approximately 25 feet vertically over a 50-foot horizontal distance. Given this steep transition zone, the HDD installation would extend beyond the toe of this slope to locate the exit point within a flatter area. This extension should improve constructability and avoid potentially creating, or being affected by, bay floor stability problems in the area of the steep slope.

Southern HDD Transition

The HDD rig for the southern landing near Potrero Switchyard would be in 23rd Street, within the HDD entry pits and splice vault work zone depicted on Figures 4-9 and 4-10. This location would allow the submarine route to land north of the existing TBC transmission line. Water depth in the bay near the onshore portion of the HDD boring is less than 10 feet for the first 400 feet; it then gradually slopes down and levels off to a depth of approximately 35-40 feet about 1,500 feet from the shoreline.

Submarine Cable

The submarine cable system would continue the transmission line with one 230 kV-rated circuit using one single conductor cable per phase. Accordingly, the submarine portion of the transmission line would consist of three parallel cables (one for each phase of the circuit). Circuit ground wire and the communications cables would each be bundled with separate phase cables. The cables would have a minimum separation of approximately 33 feet in the shallower water areas and a maximum separation of approximately 150 feet in deeper water. Typically, submarine cables are separated from one another by a distance equal to two or three times the water depth to provide mechanical protection and facilitate any necessary repairs (p. 2-23 of PG&E, 2012a).

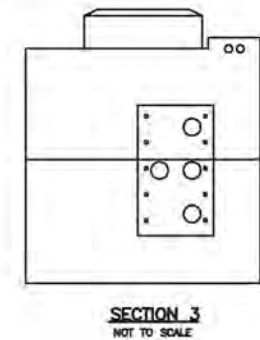
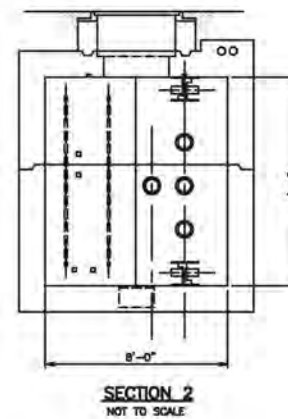
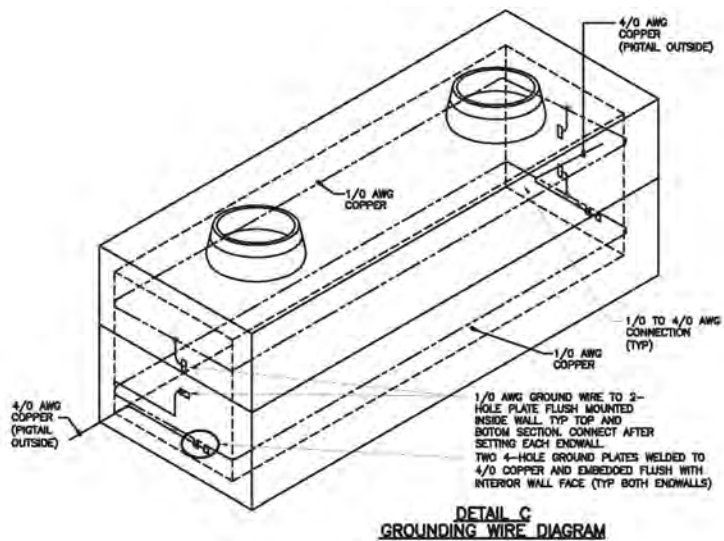
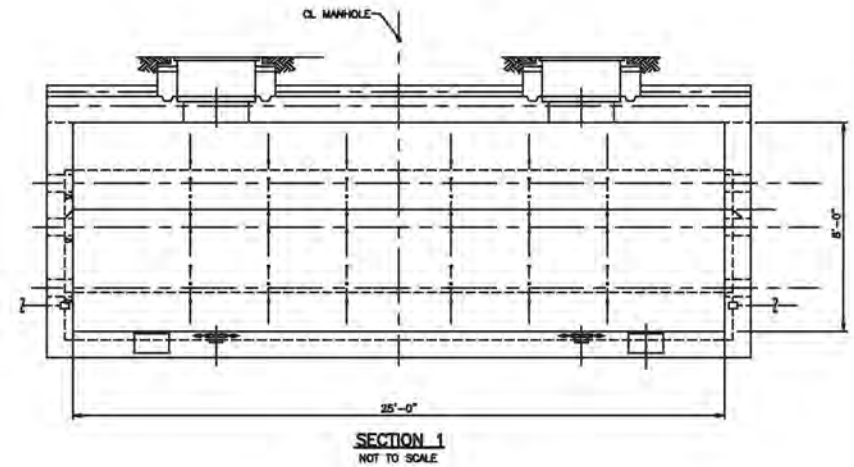
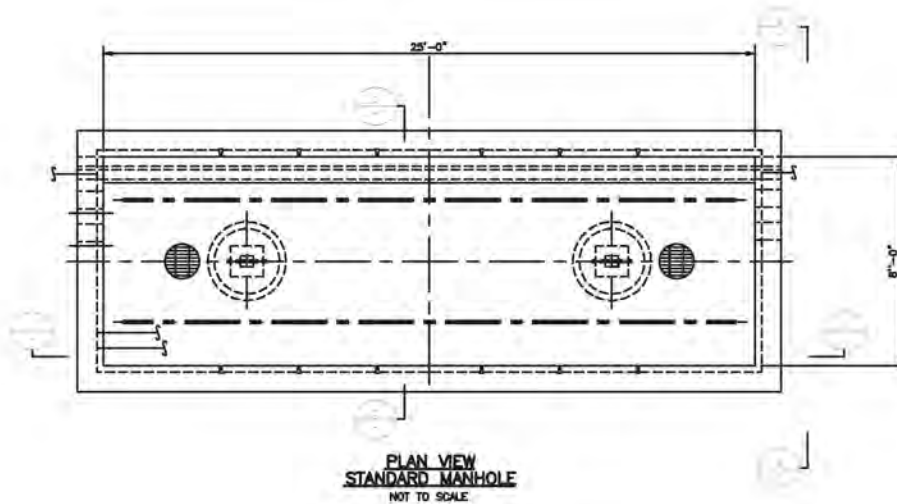

Expected and typical project submarine cable parameters are shown in Table 4-2. Along the northern HDD under The Embarcadero, the depth would be a minimum of 50 feet, which would be deeper than typical, to avoid the existing sewer collection/transportation box and the rock dike at the shoreline.

Table 4-2. Submarine Cable Parameters, Approximate Distances and Depths

| Submarine Cable Component | Approximate Distance or Depth |
|--|-------------------------------|
| Approximate Submarine Cable Route | 2.5 miles |
| Maximum Sea Water Depth | 80 feet |
| Typical Cable Burial Depth – Offshore | 6–10 feet |
| Typical Cable Burial Depth – HDD | 30 feet |
| Minimum Cable Burial Depth – Northern HDD at The Embarcadero | 50 feet |
| Expected Minimum Cable Spacing – Offshore | 33 feet |
| Expected Maximum Cable Spacing – Offshore | 150 feet |
| Expected Minimum Cable Spacing – HDD | 10 feet |

Source: Table 2-2 of PG&E, 2012a.

Each of the submarine cables would be directly buried using a hydroplow into the bay floor to a depth of approximately 6 to 10 feet below the bay floor; see Figure 4-11 and 4-12. The water depth is less than 10 feet at The Embarcadero seawall between the piers. The water depth increases to 80 feet approximately 850 feet east of Piers 28 and 30/32, near the proposed northern HDD exit point. The water depth slopes gradually up to 35-40 feet at the southern HDD exit location.

A double copper or steel armored 2800 kcmil (1400 mm²) cable with solid-dielectric copper conductor, XLPE insulation, and a lead sheath would be used to satisfy the project electrical loading requirements; see Figures 4-13a and 4-13b for the two cable options.² The sizing is based on the typical HDD depth and conservative design parameters that may be finalized during detailed design.

4.10.2 Embarcadero 230 kV Bus Upgrade Project

The existing Embarcadero Substation is at the corner of Fremont and Folsom Streets in the Rincon Hill area. The substation is located inside a multi-story building clad in precast concrete architectural panels and constructed in 1974. A basement beneath the entire building plan is used for the medium voltage and existing 230 kV cable entries as well as the heating, ventilation, and air conditioning (HVAC) equipment. Electrical equipment within the Embarcadero Substation includes air-insulated buses, switchgear, and banks of 230/34 kV and 34/12 kV transformers. The substation is not tied into PG&E’s 115 kV transmission network.

PG&E does not propose to modify the existing Embarcadero Substation as part of the project (PG&E’s Response 4, PG&E, 2012b). No new substation work at Embarcadero Substation would be required beyond that already underway in a separate reliability project involving design changes and equipment replacement at Embarcadero Substation (the Embarcadero 230 kV Bus Upgrade Project).

PG&E would terminate the proposed Embarcadero-Potrero cable at the new gas-insulated switchgear currently under development as part of the Embarcadero 230 kV Bus Upgrade Project. PG&E’s Embarcadero 230 kV Bus Upgrade aims to address reliability risks associated with the existing bus configuration

² Submarine cable sizes are expressed in square millimeters and English units according to the standards of the International Electrotechnical Commission (ICE).

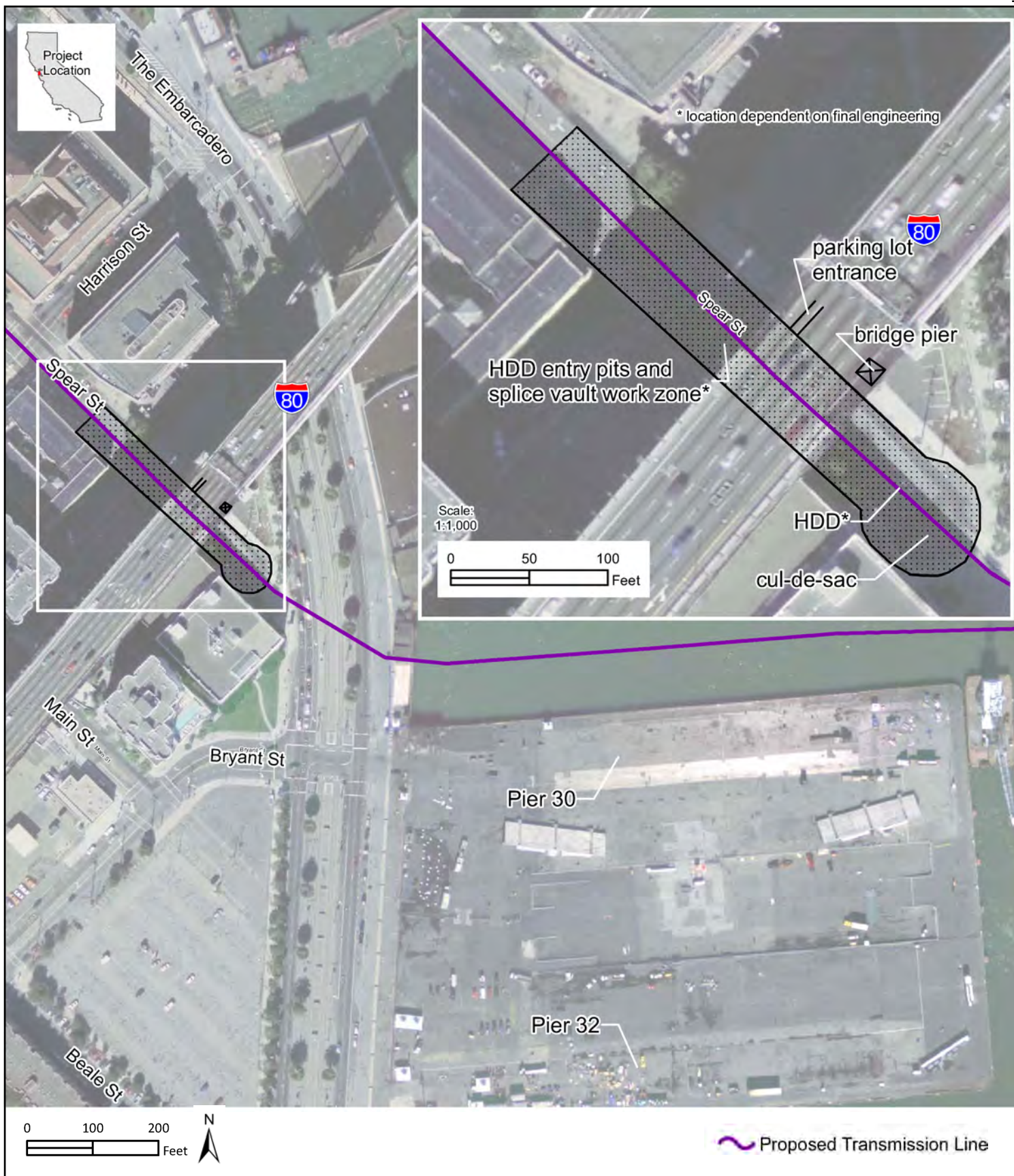
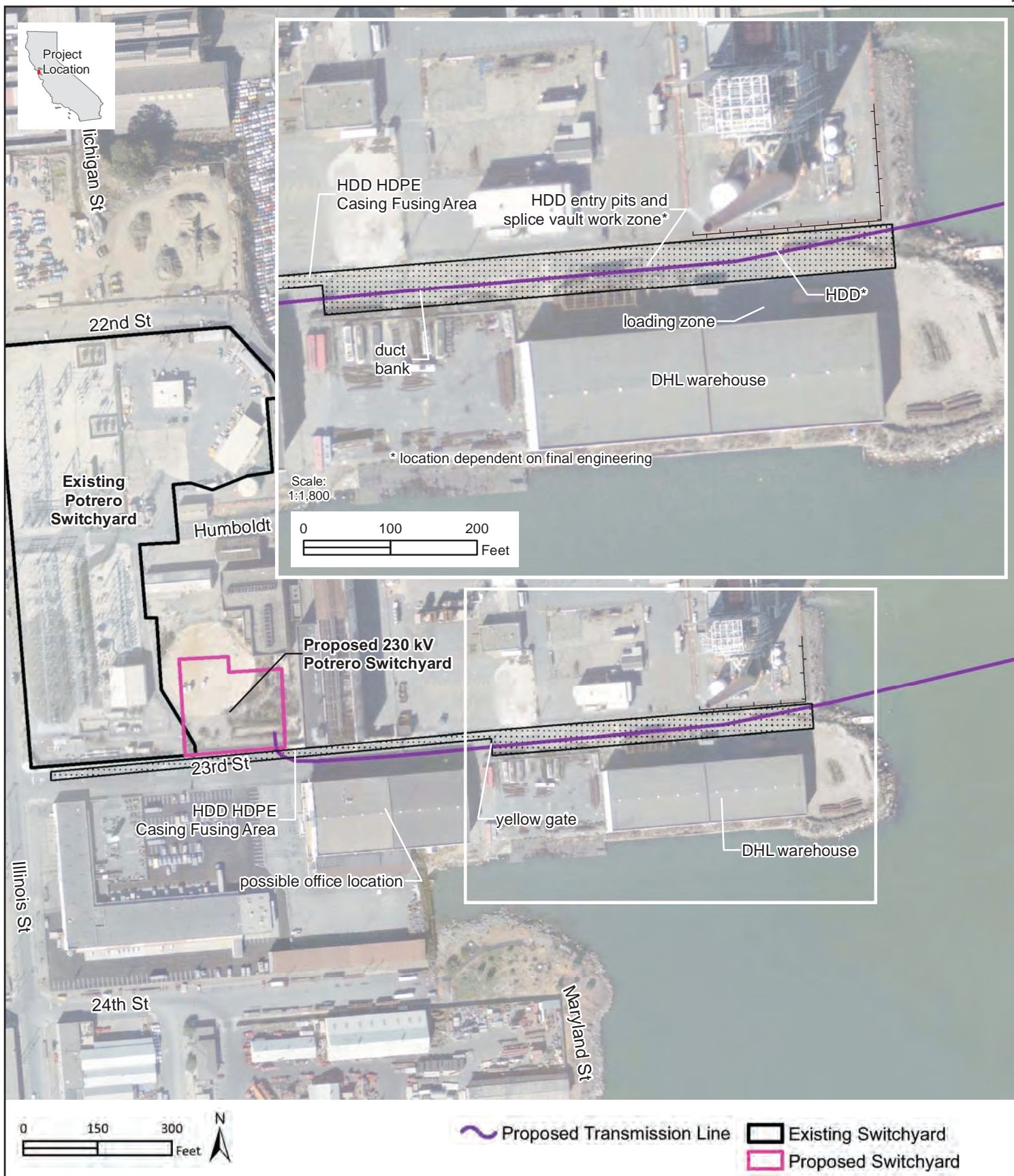
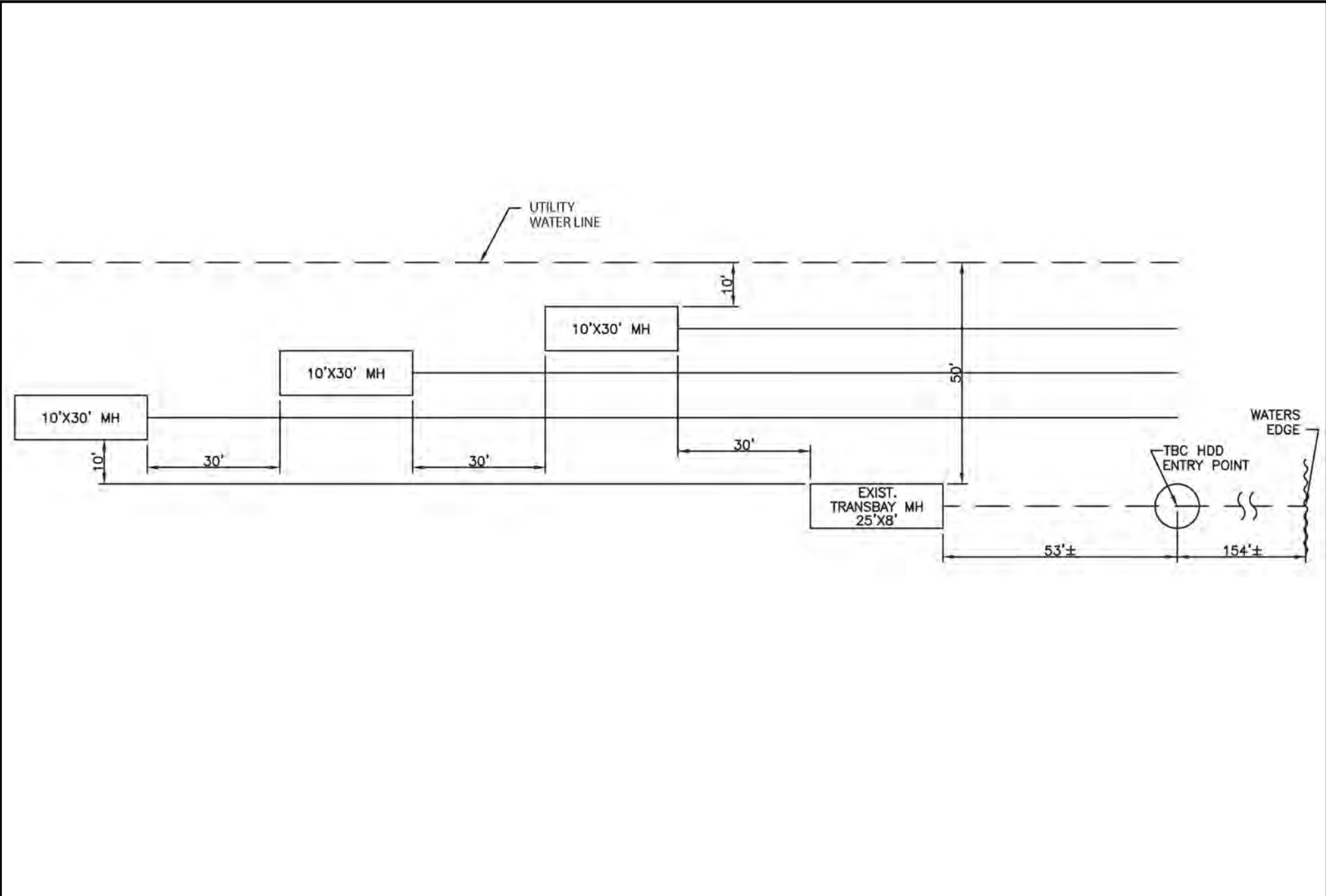

Figure 4-8
Embarcadero HDD Transition Area

This page intentionally blank.



This page intentionally blank.



Source: PG&E, 2012.

Figure 4-10
Southern HDD Transition
Manhole Layout

This page intentionally blank.

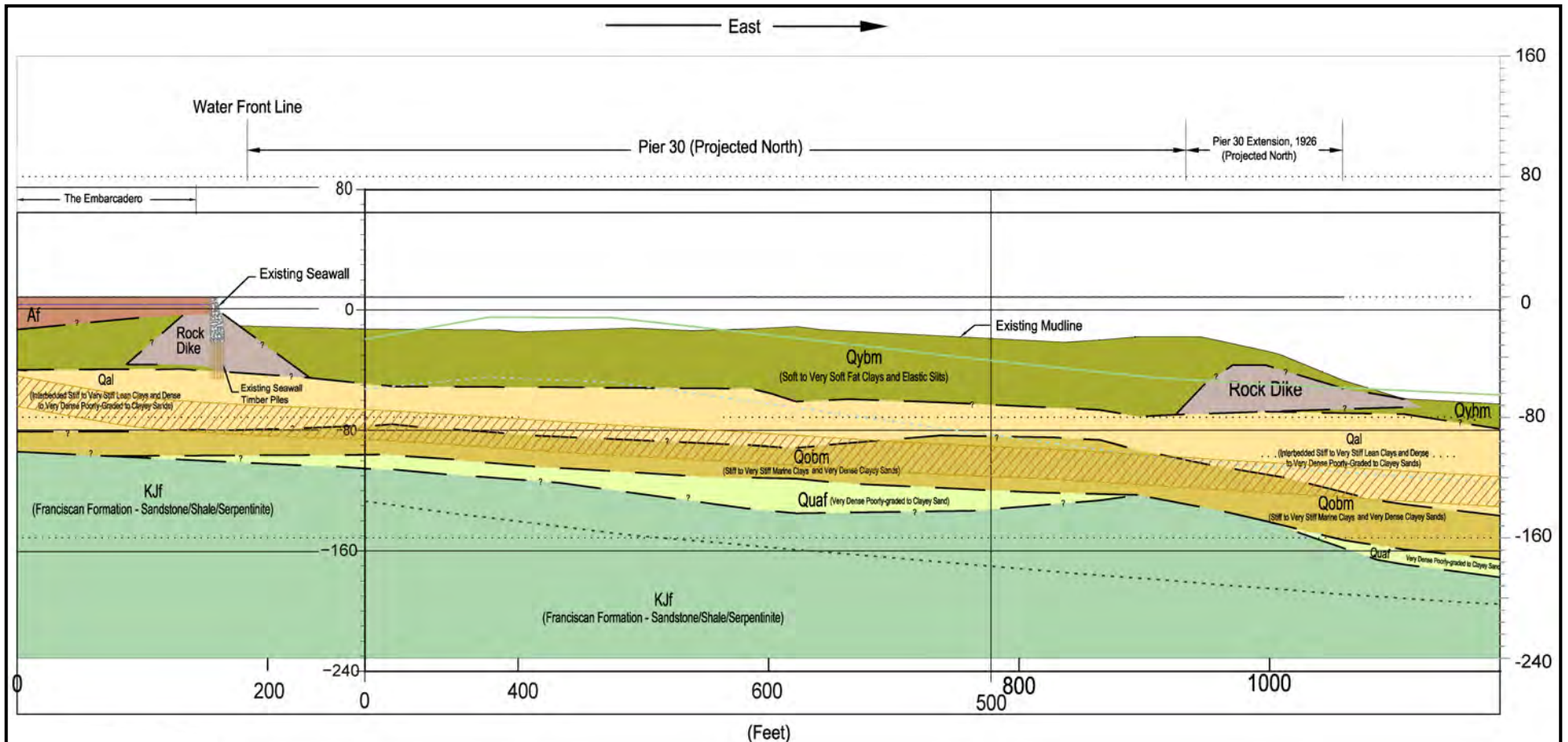

LEGEND

- | | | | |
|---|------------------------------|--|--|
| Af | Artificial Fill | | Bottom of Bay Mud (CDMG 1969) |
| Rock Dike | Rock Dike | | Top of Bedrock (CDMG 1969) |
| Qybm | Young Bay Mud | | Bottom of Bay Mud from Nearby Explorations |
| Qal | Alluvial Deposits | -? | Top of Bedrock from Nearby Explorations |
| Qobm | Old Bay Mud | | HDD Path |
| Quaf | Alameda Formation | | |
| KJf | Franciscan Formation - Shale | | |

Figure 4-11
Geologic Profile of North Transition
from Land to Marine

This page intentionally blank.

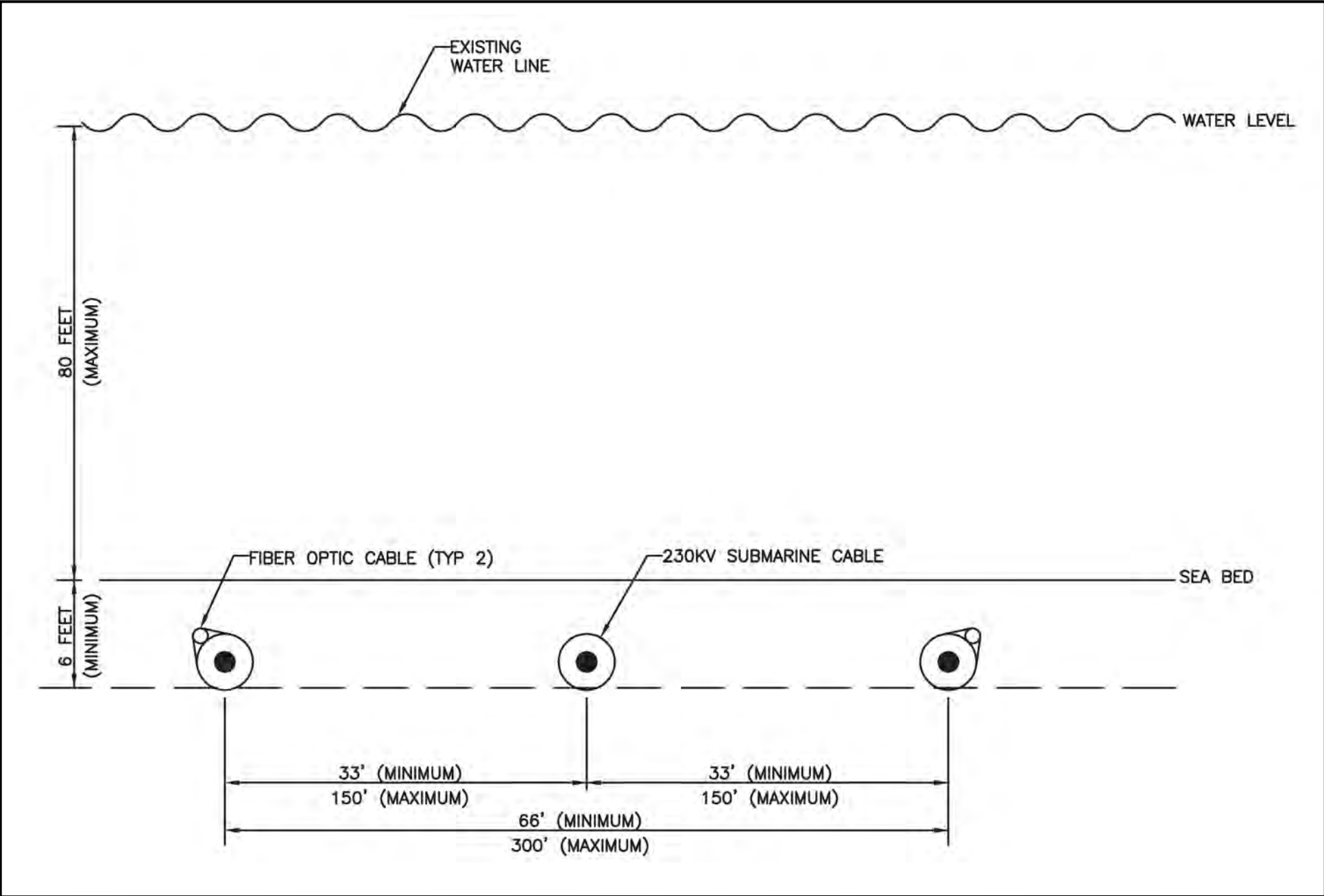

This page intentionally blank.

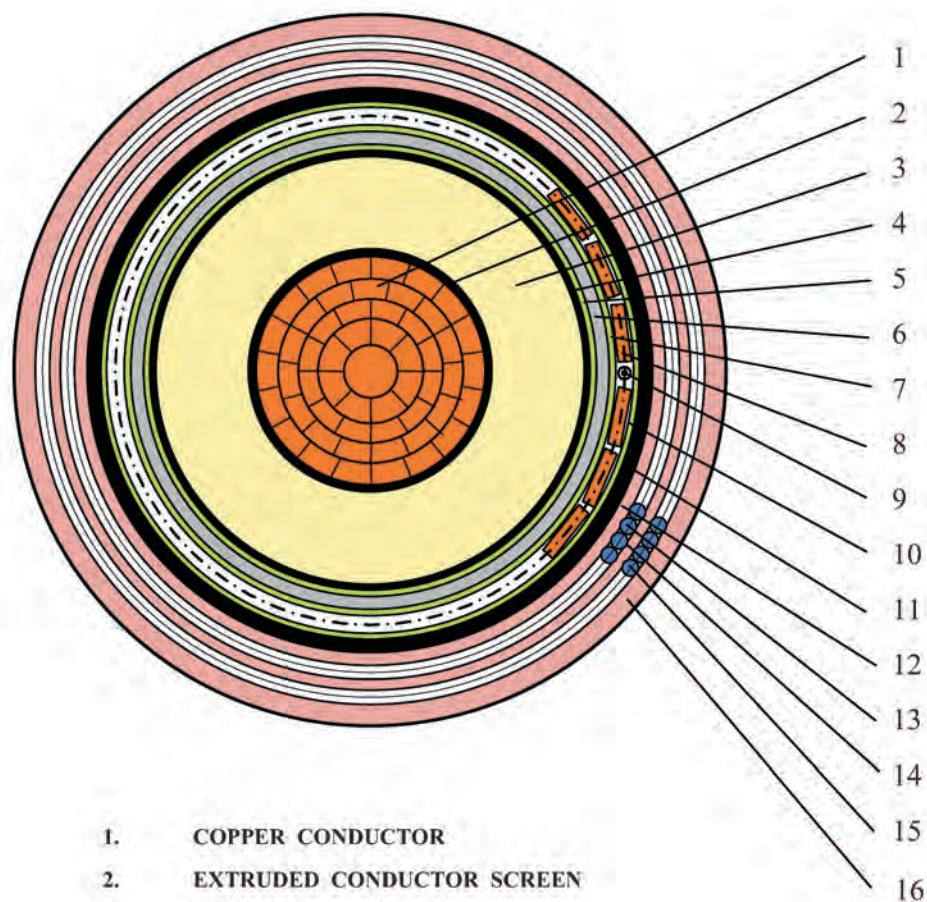

1. COPPER CONDUCTOR
2. EXTRUDED CONDUCTOR SCREEN
3. XLPE INSULATION
4. EXTRUDED INSULATION SCREEN
5. SEMI CONDUCTING SWELLING TAPE(S)
6. LEAD ALLOY SHEATH
7. SEMICONDUCTING SWELLING BEDDING TAPE(S)
8. FLAT COPPER WIRE SHIELD
9. OPTICAL FIBER IN STAINLESS STEEL TUBE
10. SEMI CONDUCTING SWELLING BINDER TAPE(S)
11. POLYETHYLENE SHEATH
12. POLYPROPYLENE YARN BEDDING
13. FIRST STEEL WIRE ARMOR
14. POLYPROPYLENE YARN BINDER
15. SECOND STEEL WIRE ARMOR
16. POLYPROPYLENE YARN SERVING

Figure 4-13a

Cross Section of the Proposed 230 kV XLPE Submarine Cable with Double Steel Armoring Design

This page intentionally blank.

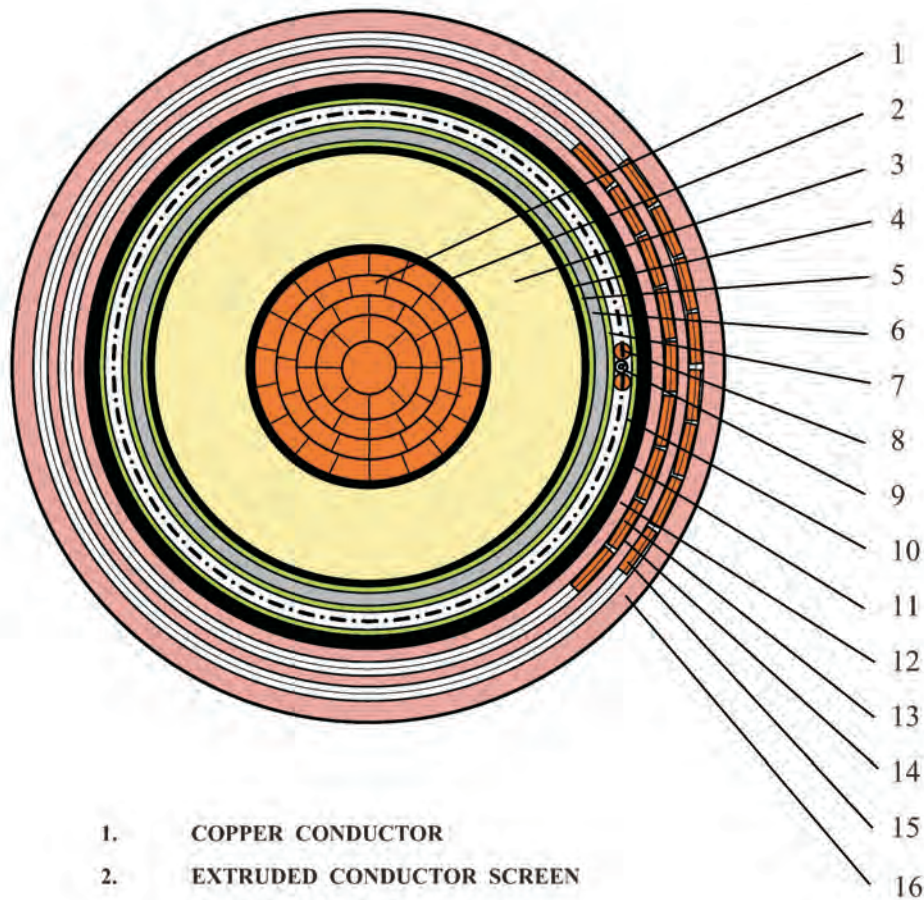

1. COPPER CONDUCTOR
2. EXTRUDED CONDUCTOR SCREEN
3. XLPE INSULATION
4. EXTRUDED INSULATION SCREEN
5. SEMI CONDUCTING SWELLING TAPE(S)
6. LEAD ALLOY SHEATH
7. SEMICONDUCTING SWELLING BEDDING TAPE(S)
8. COPPER WIRE SHIELD
9. OPTICAL FIBER IN STAINLESS STEEL TUBE
10. SEMI CONDUCTING SWELLING BINDER TAPE(S)
11. SEMI CONDUCTING POLYETHYLENE SHEATH
12. POLYPROPYLENE YARN BEDDING
13. FIRST FLAT COPPER WIRE ARMOR
14. POLYPROPYLENE YARN BINDER
15. SECOND FLAT COPPER WIRE ARMOR
16. POLYPROPYLENE YARN SERVING

Figure 4-13b

Cross Section of the Proposed 230 kV XLPE Submarine Cable with Double Copper Armoring Design

This page intentionally blank.

by incorporating “breaker-and-a-half” configuration, where two main buses are connected through “bays” of three circuit breakers in series so that the failure of any one circuit breaker would not extensively interrupt power. If the new switchgear is delayed, until the Bus Upgrade is complete, PG&E would modify the substation bus inside the northwest corner of the existing Embarcadero Substation to allow temporary termination of the Embarcadero-Potrero cable.

PG&E expects to implement the bus upgrade whether or not the Embarcadero-Potrero 230 kV Transmission Project is approved as proposed (Advice Letter 4085-E, filed by PG&E July 17, 2012; effective August 16, 2012). The Embarcadero 230 kV Bus Upgrade Project was found categorically exempt from CEQA by CPUC in August 2012. As of January 10, 2013, the date that CPUC determined the application to be complete for the proposed Embarcadero-Potrero 230 kV Transmission Project, construction had not yet begun on the Embarcadero 230 kV Bus Upgrade.

4.10.3 Potrero 230 kV Switchyard

The existing Potrero Switchyard is located on Illinois Street between 23rd and 22nd Streets in what is known as the Dogpatch neighborhood in the San Francisco Central Waterfront area. The facility is an open yard that operates as a 115/12 kV substation; however, for naming consistency, PG&E refers to the site as Potrero Switchyard. Currently, there is no 230 kV equipment at the existing Potrero Switchyard. To accommodate the proposed 230 kV cable, the project would include construction of a new 230 kV switchyard and 230/115 kV substation within about one acre on a parcel owned by [GenOn Energy, Inc/NERG Potrero LLC](#). PG&E would need to acquire this property through a fee simple transaction or condemn the property for utility use. The site is located on 23rd Street, adjacent to and east of the existing switchyard; see Figure 4-4.

Due to space constraints at the proposed site, the new 230 kV switchyard would feature gas-insulated switchgear (GIS) housed in an estimated 8,500-square-foot building with basement; see [Figure 4-14a \(Revised Site Plan for Proposed Potrero 230 kV Switchyard\)](#) and [Figure 4-14b \(Revised Parcel Map for Private Land Rights Acquisition near Potrero Switchyard\)](#). The switchgear, associated automation and control systems, and station service systems (i.e., AC power equipment to supply the building) would be inside. Up to 8,000 cy would need to be excavated and exported for the building basement and duct bank between the new switchyard building and the 115 kV buses at the south end of the existing Potrero Switchyard.

The proposed Potrero 230 kV Switchyard and GIS building area would require [acquisition of](#) a site of approximately [1.025 acres or 44,700](#)~~41,200~~ square feet. Impermeable surfaces would include the building roof of approximately 8,500 square feet and concrete or paved outdoor equipment areas of approximately 10,000 square feet. Additionally, the remainder of the yard (approximately ~~2326,000~~ square feet) would likely have a combination of gravel and concrete/asphalt surfaces. Preliminary foundation evaluation suggests deep-foundation systems may be needed for some of the structures within the new Potrero 230 kV Switchyard, including the GIS building (PG&E, 2013a).

The basement of the new GIS building would contain electrical conduits, trays and cables to interconnect the electrical equipment on the main floor. The layout would include a spare bay with space for an additional 230 kV transformer and shunt reactor. Although there is no proposal for an additional 230 kV supply, ongoing studies, such as the CAISO San Francisco Peninsula Reliability Assessment (discussed in Section 1.5), may determine a need for a second 230 kV connection into Potrero Switchyard in the future. Duct banks to the existing 115 kV Potrero Switchyard and the proposed submarine cable would enter and exit the new 230/115 kV substation building via the basement; ~~see~~ [Figures 4-15a, 4-15b and 4-15c show revised profile drawings for the proposed Potrero 230 kV Switchyard](#).

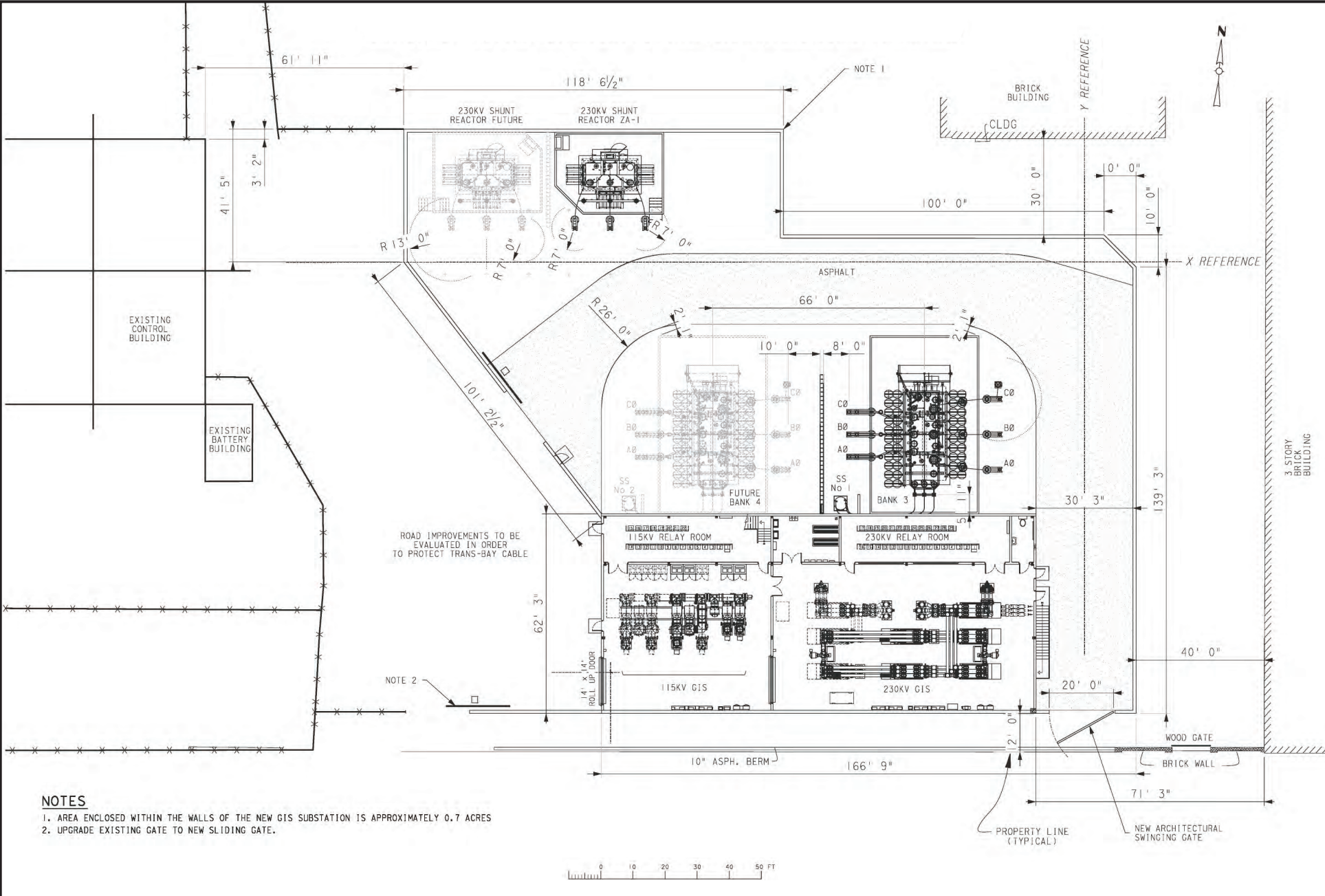

Source: PG&E, 2013b.

Figure 4-14a
Revised Site Plan for Proposed
Potrero 230 kV Switchyard



Figure 4-14b

Revised Parcel Map for Private Land Rights
Acquisition near Potrero Switchyard)



Source: PG&E, 2013b.

This page intentionally blank.

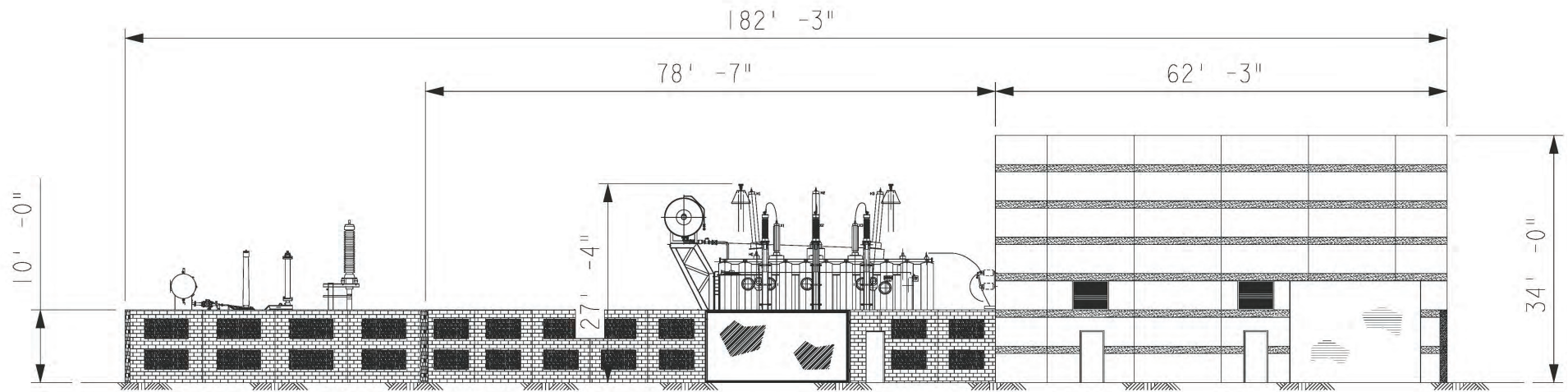

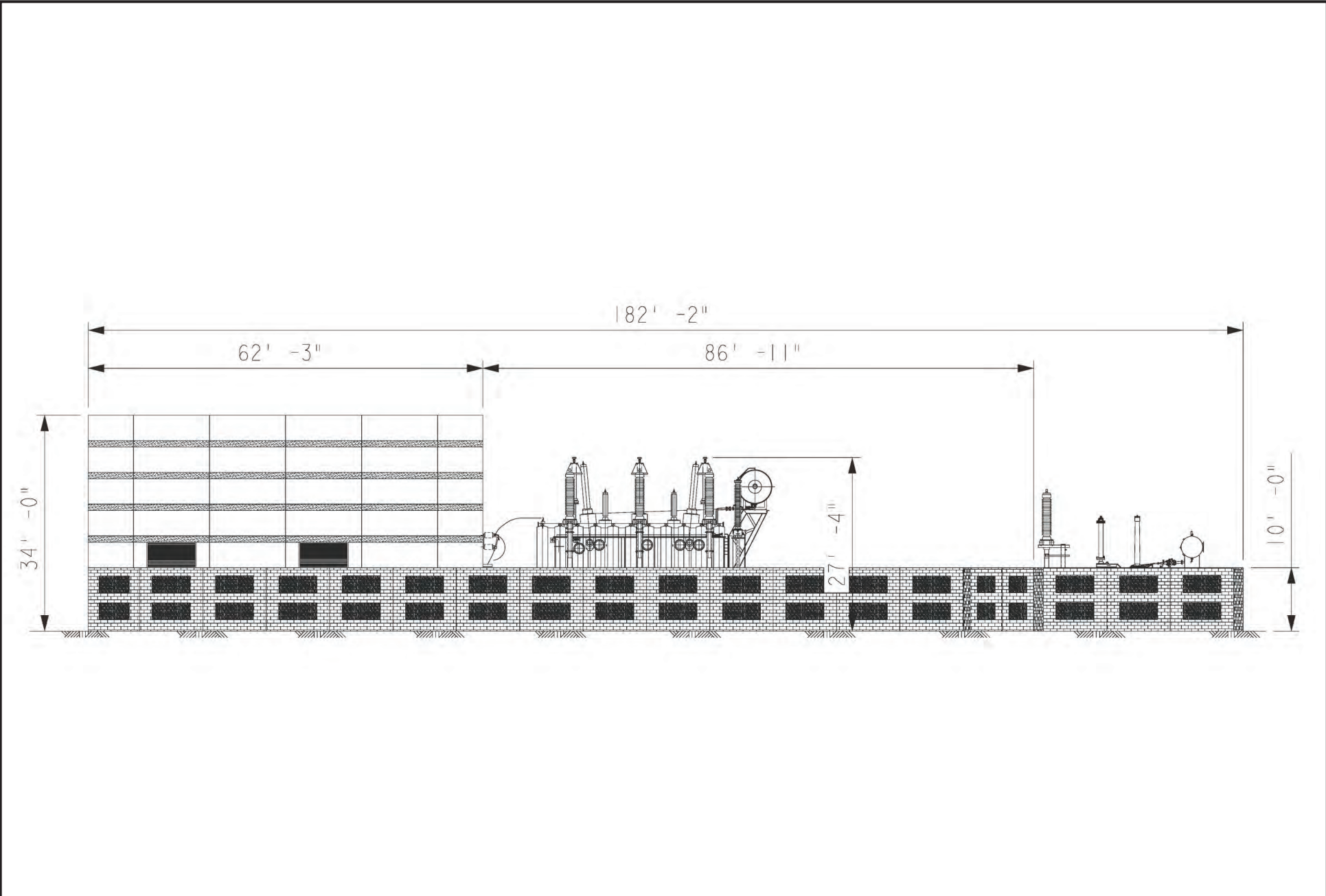

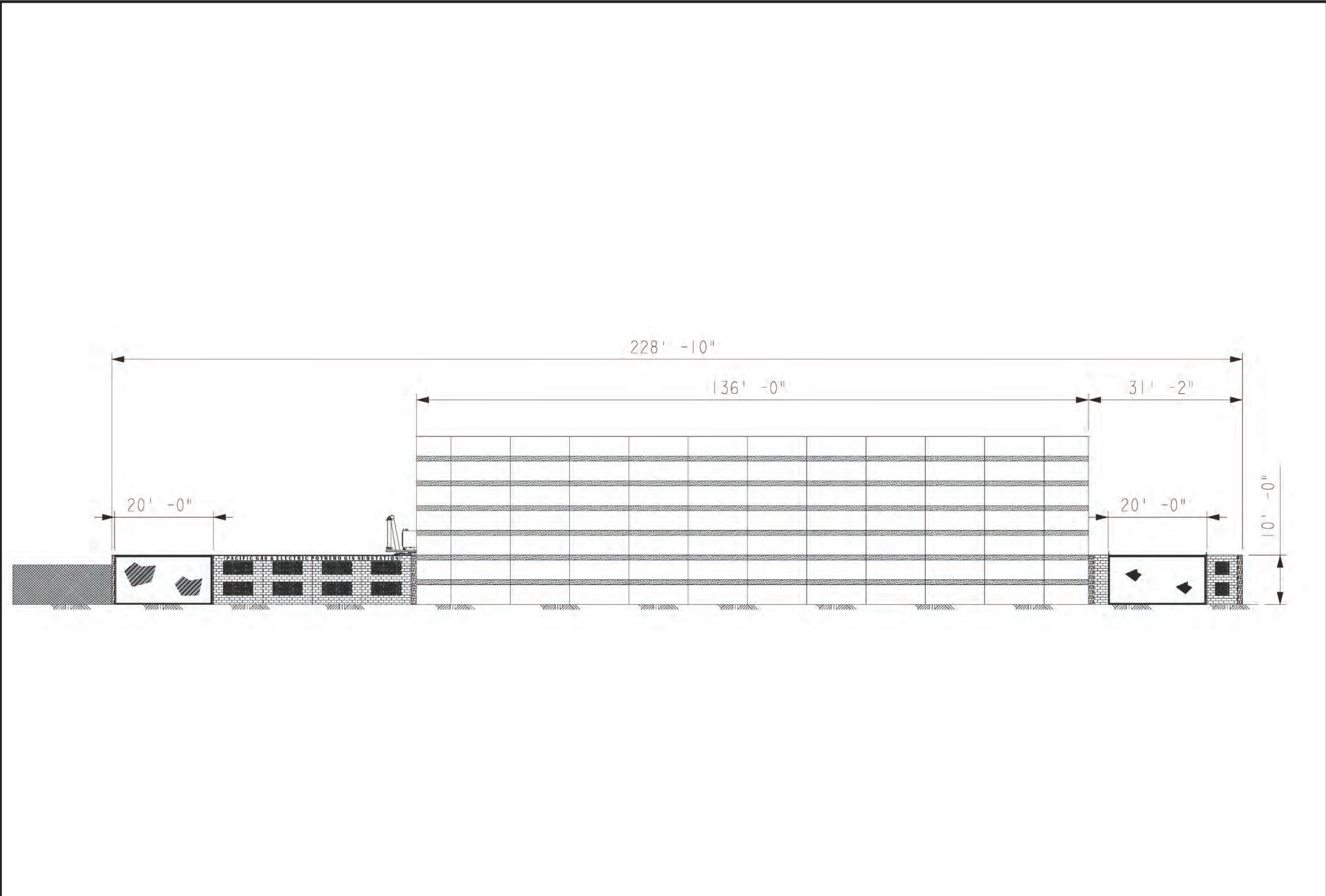

Source: PG&E, 2013b.

Figure 4-15c
Revised Potrero 230 kV
Switchyard North Elevation

The building height would be approximately 40-34 feet above grade to accommodate the GIS electrical equipment and a parapet wall, and building dimensions would be approximately 136 feet by 62 feet. The building's cladding would be a light neutral color with a non-reflective finish (p.3.1-20 of PG&E, 2012a). Including the outdoor equipment, the new Potrero 230 kV Switchyard would cover an area of approximately 190 feet by 110 feet with added room for maintenance vehicle access 0.7 acres (measuring all areas within the perimeter wall and façade). Outdoor equipment would be partitioned from the GIS building with firewalls. The proposed outdoor equipment includes one new 230/115 kV transformer, one new 230 kV shunt reactor, and their respective cable-to-air bushing connections. These would be shielded from the street by a new 10-foot-tall masonry wall around the perimeter of the new 230 kV switchyard, except for the southern front of the GIS building, which would act itself as the perimeter boundary on that side. The perimeter wall would include a minimum of one 20-foot-wide access gate via 23rd Street, and the wall-facility perimeter would be set back at least 3 feet away from the southern property line to allow for new landscaping. An existing gate from 23rd Street onto the Michigan Street alignment would be widened to allow for access to the western side of the facility through another gate in the perimeter off of the Michigan Street alignment. The gate in the brick wall that currently fronts Station A will-may need to be widened and the wall modified to allow adequate ingress, egress, and internal circulation access for large transformer equipment and future maintenance activities. Modification of discrete sections of the brick wall may include complete or partial removal. Any potential modification or removal of Station A buildings would be in compliance with the San Francisco Building Code Chapters 16B-C ("Unreinforced Masonry Building [UMB] Ordinance") to meet applicable seismic safety requirements. NRG Potrero LLC and the City and County of San Francisco have a Settlement Agreement for the Station A buildings³ that tolls compliance with the UMB Ordinance pending preparation of a Site Plan for the redevelopment of the entire former Potrero Power Plant site, including treatment of the Station A buildings.

Portions of the exterior yard areas that would not require Spill Prevention, Control, and Countermeasure (SPCC) oil containment may have some provisions for stormwater mitigation or control (such as pervious pavement, detention, and/or landscaping) depending on City building code requirements. Final design would be dependent on the results of the geotechnical investigation and possible chemical analysis of the site soil.

The existing SPCC/stormwater collection facilities at the Potrero 115 kV Switchyard (near the intersection of Illinois and 23rd Streets) would be utilized wherever possible and economically feasible. Storm water transport would be either by gravity flow (surface or piped), or pumping may be required depending on final hydraulic design. Small amounts of additional temporary water storage (500 to 1,000 gallons) may be utilized as part of the water transference system from the new 230 kV switchyard to the existing 115 kV switchyard area.

The proposed 230 kV switchyard would connect to the existing 115 kV switchyard through twelve underground 115 kV cables (i.e., two cables per phase per 115 kV bus); see Figure 4-16. The cables would be connected to the existing 115 kV switchyard using six single-phase tubular steel termination poles, approximately 10 feet high, with insulated terminals to a total height of approximately 17 feet. The new poles would likely be at the south end of the existing 115 kV bus, near 23rd Street. The height of the existing 115 kV bus structure is approximately 34 feet.

³ The "Station A buildings" consist of a small group of unreinforced masonry buildings on the NRG property consisting of the Station A, Meter, Compressor and Gatehouse buildings.

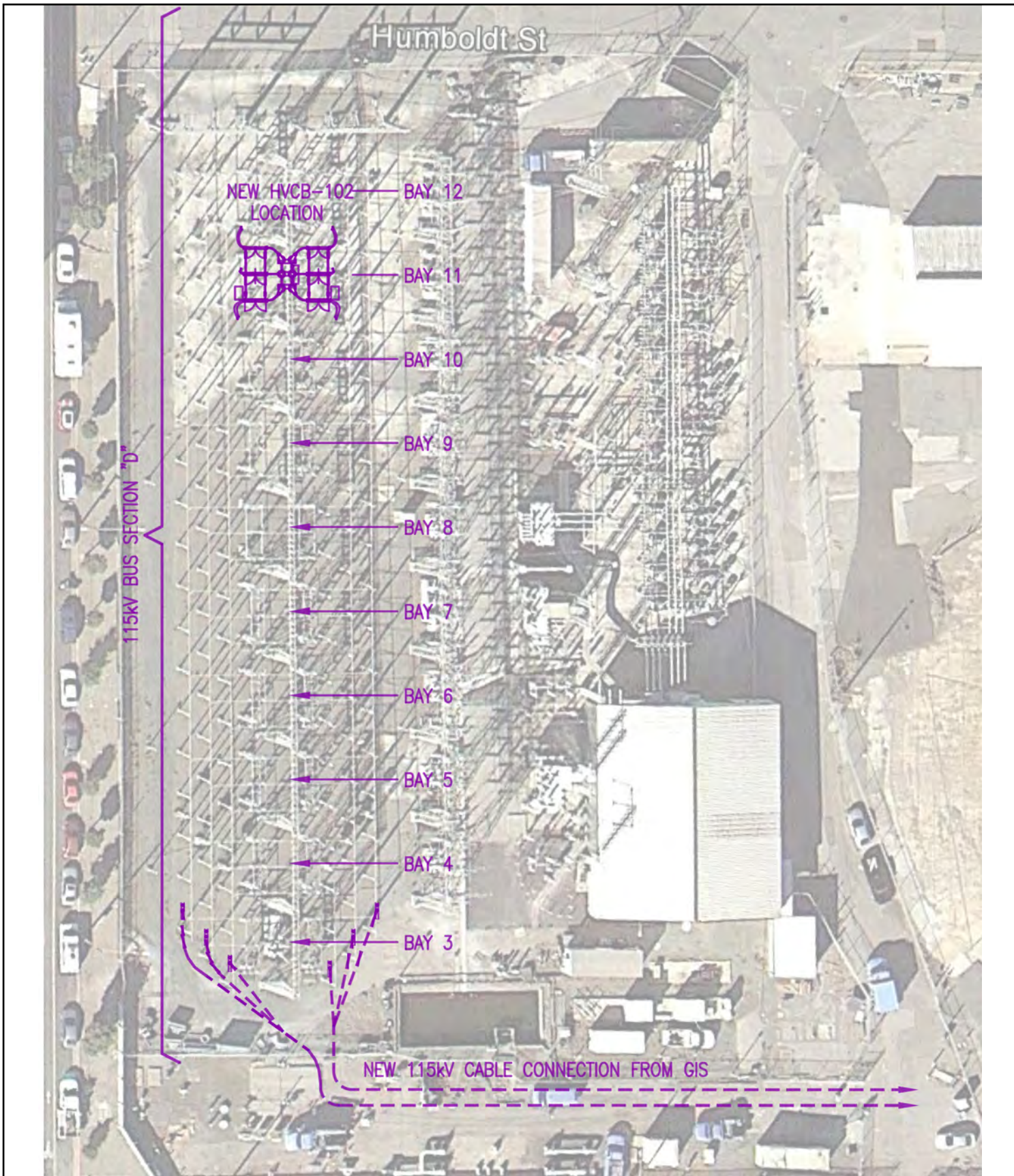

This page intentionally blank.

All new substation equipment, including cable terminations, would be seismically qualified to the High Level of Institute of Electrical and Electronics Engineers (IEEE) 693. The new 230 kV switchyard building would meet the requirements [for Occupancy Category III](#) of the California Building Code (CBC) ([Chapter 4 of PG&E, 2013c](#)).

4.11 Project Construction

This section includes an overview of the proposed construction methods and those typically used for construction of the underground and offshore portions of a 230 kV transmission line, and for work at Potrero Switchyard and Embarcadero Substation. This section includes discussion of the following:

- General construction considerations, including work areas;
- Traffic controls and lane closures;
- Staging areas;
- Easements and right-of-way;
- Underground transmission line construction;
- Substation and switchyard construction;
- Submarine cable installation, including installing the HDD transitions;
- Construction phasing; and
- Workforce and equipment.

4.11.1 General Construction Considerations

Other than staging, all onshore transmission line-related construction activities would be conducted in temporarily closed lanes along the project route. Lane closures would require additional detailed design and planning because city streets along the route would typically need to have one travel lane and one parking lane closed by PG&E during duct bank construction; see Section 4.11.2. Staging areas are discussed separately; see Section 4.11.3. Existing commercially available office and yard space may be used by contractors or agencies.

Work Areas

Trenching work areas would extend typically about 1,500 feet in length by 12 feet wide with work crews excavating and securing the trench walls via shoring. Once the shoring process is complete for approximately 500 feet, another crew would install the duct bank, and the trench would be backfilled and pavement restored. Approximately 150 feet to 300 feet of trench would be open at any one time. Staging and excavation for each vault would require approximately 1,500 square feet of work space. The sequential layout of the construction work area from the front end would include:

- 100 feet of traffic control taper/buffer zone;
- 500 feet of logistical work area for the trenching and trucking activities;
- 150 feet of trench excavation;
- 150 feet of conduit installation and backfilling;
- 300 to 400 feet of trench paving; and
- 200 feet of work area for temporary paving activities at the tail end of the construction operation.

Work areas for the HDD landing sites would be located in Spear Street and in 23rd Street. The work area for the northern HDD landing site would be approximately 500 feet by 60 feet at the Spear Street cul-de-sac, and the work area for the southern HDD landing site would be 800 feet by 50 feet along 23rd Street. An additional 800 feet of 23rd Street would be used for staging, which would extend the temporary lane closure and loss of parking between Illinois Street and the shoreline.

Cable pulling would occur after installing the underground conduits, pouring the concrete duct bank and backfilling the trench. Each cable reel and crew would require an area approximately 200 feet by 12 feet. Cable installation would occur between the southern onshore section termination at Potrero Switchyard and the Bay to land transition manholes on 23rd Street; between the northern onshore section termination at Embarcadero Substation and the Folsom Street manhole; and from that manhole to the Bay to land transition manholes at the Spear Street cul-de-sac. In conjunction with the area used by the reel trailer carrying the 12-by-6-foot-wide reels, the cable puller would also require an area approximately 100 feet by 12 feet wide.

Cable splicing procedures would typically require a single crew truck directly adjacent to each manhole. Actual splicing would occur within the buried manhole with aboveground support. The work area required for this activity is typically approximately 75 feet by 12 feet.

At work areas for trenching or HDD installation, electricity will be provided by portable “whisper-quiet” generators. The project would not require generators at the Potrero Switchyard construction area, nor at the connection to the Potrero 115 kV bus, as the old power plant station service line and/or existing distribution lines would be used as temporary power sources.

Dewatering and Groundwater Handling

Dewatering of the trench would be conducted using a pump or well points. Groundwater encountered during underground construction would be pumped into containment tanks and tested for turbidity and pH values. PG&E would discharge the pumped water into the storm sewer system when the water meets quality standards; otherwise, PG&E would dispose of it in accordance with state and federal standards.

Control containment and discharge could be performed in a variety of ways on site, such as by using holding tanks (e.g., truck trailer “Baker tanks”) that allow acceptable de-sedimentation prior to discharge. Other control containment and discharge methods could include pumping ground water directly to water trucks for haul off to a treatment facility, or with prior agreement and any necessary ministerial permits, discharge to a sewer. To discharge to a sewer, PG&E would prepare a special request for discharge and treatment of the estimated amount, as well as the cost of discharge, that would be submitted to the San Francisco Public Utilities Commission (SFPUC) Bureau of Environmental Regulation Management. Additionally, PG&E would need to obtain a water supply of approximately two 2,000-gallon truckloads per day for dust control during construction, likely through coordination with the SFPUC. The request for water supply and dewatering flows would be developed during final design (Section 2.6.2.2 of PG&E, 2012a; PG&E, 2013a).

Excavated Materials

During construction, materials removed during trench excavation would be placed directly into trucks and removed from the area and disposed of off-site. The estimated total amount of materials to be disposed of is 6,000 cy for onshore trenches, duct banks, and vaults, 300 cy for the HDD pits, and 8,000 cy for the Potrero 230 kV Switchyard basement, for a project total of 14,300 cy. Materials that are used for construction of the underground conduits, such as concrete, plastic conduit, and asphalt, would be stored onsite during construction or at staging areas.

All excavated material would be removed from the site and hauled off to an appropriate landfill based on the pre-construction characterization of soils. Since numerous dump trucks would be required for the hauling operation, trucks would be staged for rotating hauling activities. Dust control and wet sweeping best management measures would be implemented during excavation.

Pre-characterization of soils would be completed prior to construction via soil borings throughout the route. The soil borings would be reviewed and characterized for proper disposal to a landfill that on a predetermined basis can accept the different classes of soil found at the project site. In addition, once construction commences, a site-specific hazardous waste manifest system would be used for each soil disposal truck. It should be noted that, to the extent feasible, all excavated material would be hauled off immediately and not be stored on- or off site. See also Section 4.13, Applicant Proposed Measures.

Vegetation Clearance

All onshore portions of the transmission line would be underground, and all work areas would be in city streets or paved areas. In the event that vegetation clearance is needed, disturbance would be minimized to that needed for safe access.

There are over 110 trees planted along the sidewalks that line the northern project route on The Embarcadero, Spear Street, and Folsom Street near the Embarcadero Substation. Depending on the precise location of the underground line (determined during final design), some of these trees may need to be removed or trimmed. One entire row of 18 sweetgum trees (2 to 3 inches in diameter and 10 to 15 feet tall) on Spear Street between Folsom Street and Harrison Street could potentially be trimmed or removed during construction (PG&E, 2013a).

Temporarily disturbed areas would be restored to preconstruction condition once construction is complete. Any roots from trees and deep-rooted shrubs encountered during trenching or excavation would be pruned above the underground transmission line duct bank to avoid interference.

Erosion Control and Pollution Prevention

PG&E would prepare and implement an Erosion and Sediment Control Plan as part of a Stormwater Pollution Prevention Plan (SWPPP) that would be prepared for the Proposed Project. Erosion control and pollution prevention measures in the SWPPP would address elements such as track-out controls, stock-pile handling, dewatering discharge, drain inlet protection, and replacement of any disturbed pavement or landscaping.

Cleanup and Post Construction Restoration

The Proposed Project would occur in areas that are either paved, landscaped, or graveled, such as at the existing Potrero Switchyard and the affected portions of ~~GenOn~~-NRG property. Restoration would consist of removing the construction equipment and materials and repaving, restoring landscaping, or recovering with gravel or depending on the original condition of the site.

All work areas, whether vegetated or not, would be restored to conditions equal to or better than pre-construction conditions. Vegetated areas disturbed by the project could include limited street or landscaped areas that would be replanted per agreement with the City or landowner. As part of the final construction activities, PG&E would restore all removed curbs, gutters, street surfaces, and sidewalks, repave all removed or damaged paved surfaces, restore landscaping or vegetation as necessary, and clean up the job site.

Trash and litter at the job site would be collected in bins or appropriate containers easily accessible to construction crews and removed to the staging areas for off-haul to the appropriate solid waste facility. PG&E expects to characterize soils for disposal in-situ, and spoils and asphalt/concrete waste would be hauled off for appropriate disposal following characterization. All hazardous materials and hazardous wastes would be handled, stored, and disposed of in accordance with all applicable regulations, by personnel qualified to handle hazardous materials.

4.11.2 Traffic Controls and Lane Closures

All lane closures would be identified in more detail by a Traffic Management Plan that PG&E must develop in consultation with the City (Section 2.6.1.2 of PG&E, 2012a). The City would likely require a full lane of pavement restoration which in turn would require a two lane closure over a 1,500 foot work area. PG&E would apply for a Special Traffic Permit from the San Francisco Municipal Transportation Agency (SFMTA). PG&E would submit a Traffic Management Plan as part of this application. For the short-term closures of underground transmission line construction, appropriate traffic controls would be implemented during trenching and during vault installations. Traffic controls would include but not be limited to typical traffic control cones, candles, electronic signage board and temporary fixed warning signs for workmen prior to work zone in both directions, and/or Type III barricades, as specified in the Special Traffic Permit from the City of San Francisco. PG&E expects most work in temporarily closed lanes would be in franchise along the onshore portion of the route. Overall, lane closures would generally extend along one city block, or potentially portions of two blocks where working near an intersection, at any given time. However, exact lane closures can only be determined following detailed investigations into existing utilities and final construction planning. No new access roads would be developed for this project.

PG&E would also apply for a ministerial Excavation Permit from the San Francisco Department of Public Works (DPW) to allow trenching from the two landings through franchise to PG&E's properties at the transmission line termination points. The Transbay Joint Powers Authority and San Francisco Planning Department have no independent permitting jurisdiction relative to the Proposed Project. However, the Transbay Joint Powers Authority and SFMTA would be involved during review of PG&E's Traffic Management Plan, where relevant for the Special Traffic Permit.

PG&E would coordinate provisions for emergency vehicle and local access with City personnel. PG&E's coordination with emergency responders would occur prior to construction and during the construction phase. PG&E proposes to coordinate daily with all first responders to exchange information regarding the locations of crews and work areas. Additionally, for trenching in areas where access is needed crossing the trench line, steel plates would be on hand and immediately placed to provide access for the needed response.

4.11.3 Staging Areas

Onshore Staging

In addition to the use of closed lanes for underground work areas, PG&E expects that onshore staging for the Proposed Project would occur in one or more of three possible staging locations, and along 23rd Street, as follows:

- Staging Alternative 1 would be located on [GenOn-NRG Potrero LLC](#) property north of 23rd Street east of Illinois Street, to the north of the proposed Potrero 230 kV Switchyard. The L-shaped area is approximately [0.90.76](#) acres extending north of the proposed switchyard construction work area, comprising of [two-three](#) rectangular shaped areas approximately [215-135](#) feet by [60-145](#) feet, [120 feet by 25 feet](#), and [170-160](#) feet by [140-65](#) feet.

- Staging Alternative 2 would be located on [GenOn-NRG](#) property in a paved area to the east of the proposed Potrero 230 kV switchyard. The L-shaped area is approximately 1.5 acre, comprising of two rectangular shaped areas approximately 325 feet by 140 feet and 90 feet by 220 feet.
- Staging Alternative 3 would be located on Port of San Francisco property on Amador Street near Cargo Way. It is a rectangular paved area, with an estimated area of approximately 2.3 acres (430 feet by 230 feet).

Figure 4-5 illustrates the potential locations for staging onshore activities. In addition, PG&E or agency contractors could decide to use commercially available office or yard space in San Francisco and the Port of Oakland to base their operations; any such existing office or yard space will have already been subject to city permitting requirements.

HDD staging would occur along 23rd Street and in the public street. This area would be used for all pipe fusion and pipe casing work to stage both the northern and southern HDD. The work area in 23rd Street would extend to the water's edge, where fused sections of the HDPE conduit would be connected to a small boat, floated, and tugged to the points of each HDD exit (PG&E, 2013a).

The proposed HDD staging site along 23rd Street (Figure 4-9) would be approximately 1,600 feet in length by 20 feet wide. Approximately half or 800 feet of the staging area would be located in the public street, and would result in the temporary loss of street parking for 70 spaces. The remainder of the closure along 23rd Street would be [approximately](#) 800 feet by [50-40](#) feet for the southern HDD landing work area.

Submarine Work Staging

Crews for submarine work would need to board crew boats from an existing commercial marina such as the Yerba Buena Island Marina, and be taken to the designated anchoring locations of the project vessels. PG&E has not proposed any specific anchoring points or locations for staging the marine crews. Given that anchoring locations vary each day based on local ship traffic, project-related vessels and barges would be directed daily regarding anchoring locations via the Vessel Traffic Service of San Francisco and the U.S. Coast Guard.

4.11.4 Easements and Right-of-Way

The onshore portions of the project, including the two HDD termination points, would be located primarily in franchise in city streets or PG&E-owned property with the exception of a portion of the southern landing area. At the northern landing area, the line would pass through City streets and areas owned by the State of California (Caltrans, for the portion under the Bay Bridge). The portion of the submarine route in the San Francisco Bay would require a license from the Port of San Francisco.

The southern landing location at 23rd Street would require approximately ~~38,000~~[23,200](#) square feet of right-of-way acquisition from the shoreline to a gate located approximately 760 feet west from the shoreline. In addition, the Potrero 230 kV Switchyard site would need to be acquired in fee simple or by condemnation from landowner [GenOnNRG Potrero LLC](#), and a License would need to be obtained from the Port for use of Port property (Section 2.5 of PG&E, 2012a).

[A](#) Temporary Construction Easements [approximately 5040](#)-feet wide and permanent easements would be negotiated by PG&E and acquired from private property owners. PG&E indicates that all private property is in Port's jurisdiction. Two sections of the cable are in private property. The first is in the DHL facility [GenOnNRG Potrero LLC property](#) at 401 23rd Street. The [DHL GenOnNRG](#) parcel extends 760 feet from the shoreline to the franchise area. Both a temporary and a narrower permanent easement would be required in that area.

The second piece of the cable route in private property is approximately 100 feet long connecting the proposed Potrero 230 kV Switchyard to the proposed cable in franchise in 23rd Street. This property would be part of the switchyard acquisition from landowner ~~GenOn~~NRG. A portion of cable route that extends approximately 400 feet appears to be outside the Port's jurisdiction but is within franchise in 23rd Street.

4.11.5 Underground Transmission Line Construction

This section describes the proposed construction methods for construction of the underground transmission line. Installation of the underground transmission line, duct banks, and splice vaults would be completed using a cut-and-cover method (open trenching) along the majority of the route. The major underground construction activities would begin with vault installation, followed by trenching and duct bank installation, and, finally, cable installation.

4.11.5.1 Trenching/Duct Bank Installation

Prior to trenching, PG&E would notify other utility companies (via the Underground Service Alert [USA]) to locate and mark existing underground structures along the proposed alignments, and also would conduct exploratory excavations (potholing) to prove the locations for proposed facilities as needed. PG&E would apply for a ministerial Excavation Permit from the City for trenching in City streets. No complete long-term road closures would be expected during trenching, although one-way traffic controls as well as short-term road closures up to 1,500 feet would be necessary to allow for certain construction activities and to maintain public safety.

After the route is marked, the pavement within the trenchline would be removed. Trenching activity requires one work crew progressively excavating, hauling off material, and backfilling. Upon reaching final trench excavation depth, a second work crew secures the trench walls via shoring. Once the shoring process is complete, a third installs PVC conduit to provide a raceway for the electrical cable. Upon completion of PVC conduit laydown, the trench is backfilled and the trench alignment temporarily paved. This progression would continue between each HDD transition area and the points of termination at Embarcadero Substation and Potrero Switchyard. Final roadway restoration and asphalt paving would be completed once the cable is fully installed, tested and released to operations. This to avoids having to break the final pavement to replace any section of cable should it failed during testing.

Trenching would progress at an approximate rate of 50 feet per day. The length of open trench at any one time would typically be 150 feet to 300 feet on any street, depending on the City's permitting requirements. Steel plating would be placed over the trench to maintain vehicular and pedestrian traffic across areas that are not under active construction. Traffic controls would also be implemented to direct local traffic safely around the work areas (see Section 4.11.2). The total surface of the trench plates over backfilled areas would vary between approximately 100 to 500 feet in length each day until it has reached a surface large enough (typically 300 feet) for temporary pavement restoration. Trench paving would likely occur once a week to minimize the amount of trench plates on the road.

As the trench for the underground 230 kV cable is completed, PG&E would install PVC cable conduits and concrete encasement duct bank. The duct bank cover would measure at least 36 inches. The typical dimensions of a single circuit reinforced duct bank are approximately 3 feet 7 inches wide by 3 feet 4 inches deep, although typical dimensions may vary depending on soil stability and the presence of existing substructures (Figure 4-6). The trench would be widened or shored where needed to meet California Occupational Safety and Health Administration (OSHA) safety requirements.

Where the electrical transmission duct bank would cross or run parallel to other substructures (which have operating temperatures at earth temperature), a minimum radial clearance of 12 inches would be required. These substructures include gas lines, telephone lines, water mains, storm lines, and sewer lines. In addition, a 5-foot minimum radial clearance would be required where the new duct bank crosses another heat-radiating substructure at right angles. A 15-foot minimum radial clearance would be required between the duct bank and any parallel substructure whose operating temperature significantly exceeds the normal earth temperature. Such heat-radiating facilities may include other underground electric transmission circuits, primary electric distribution cables (especially multiple-circuit duct banks), steam lines, or heated oil lines.

PG&E would identify utilities during final design, evaluate their proximity and potential for induced current and/or corrosion, and in coordination with the utility-system owner, determine whether steps are necessary to reduce the potential to induce current or cause corrosion. PG&E would take the necessary steps in coordination with those utility system owners to minimize any potential effects through measures, such as increased cathodic protection or utility relocation. The steps are summarized as follows:

- During final design, prepare study of corrosion and induced currents.
- Send results of study to each affected utility system owner for review and comments.
- Owners submit requirements for protection of each of their facilities.
- PG&E makes changes accordingly or compensates owner for future protection measures, per the owner's preference.

Once the PVC conduits are installed, thermal-select or controlled backfill would be transported, placed, and compacted. A road base backfill or slurry concrete cap would be installed, and the road surface would be restored in compliance with the City permits. While the completed trench sections are being restored, additional trenchline would be opened farther down the street. This process would continue until the entire conduit system is in place.

All backfilling material would be engineered material called flowable thermal concrete (FTC), and flowable thermal backfill (FTB). Each has unique properties specific to its application, while both are designed to have thermal characteristics for heat displacement. For a typical trench, the bottom 2 feet encases the PVC conduit with FTC, while the remainder of the trench would be filled with City-approved "diggable control density fill" FTB to the roadway sub-base level. From that point, all restoration would be based upon matching the street's existing sub-base and surface, i.e., asphalt, concrete, or combination of the two. The excavated material would not be used as backfill (see Section 4.11.1, Excavated Materials). The estimated total amount of excavated materials to be removed for trenches, duct banks, and vaults is 6,000 cy.

The total duration of trench excavation and manhole installation, not including cable pulling and HDD operations, is estimated to take approximately four months along the northern underground segment, and two months along the southern underground segment. Cable pulling, discussed in Section 4.11.5.3, is a standalone operation that would be performed after the vaults are installed, the duct bank is fully poured, and the trench back-filled and temporarily paved. Final paving restoration would be scheduled after the cable is fully installed and operative. The San Francisco paving permit would likely require a full lane of pavement restoration which in turn would require a two lane closure over a 1,500 foot work area. Final paving would take 5 days along Spear and Folsom Streets and 2 days on 23rd Street.

Equipment necessary for trenching in closed lanes and HDD work areas include pavement saw cutting equipment, pavement grinder, excavators, and dump trucks. Pavers would be used for restoration.

(PG&E, 2013a). Section 4.11.9 lists all equipment expected to be used during construction. PG&E expects 4 dump trucks to be used to haul trench and excavation materials and import backfill to the project. The number of daily total haul truck trips would depend upon the rate of the trenching, which is estimated to progress at an approximate rate of 50 feet per day over 6 months. Jackhammers would be used when needed to break up sections of concrete that the saw-cutting and pavement-breaking machines cannot reach. Other miscellaneous equipment would include a concrete saw, various paving equipment, and pickup trucks (see also Section 4.11.9). In general, no equipment would be left at the trench site overnight, with the exception of an excavator.

4.11.5.2 Vault Installation

The typical complete pre-cast vault installation would take 4 to 7 days, working 10 hours per day from breaking ground to finishing grade. For each vault, the excavation would be approximately 34 feet long, 14 feet wide and up to 15 feet deep. Excavation for vaults of this size would require shoring components such as driven sheet piles, or slide rail steel sheeting. Once the initial excavation and shoring is installed, preparation of the sub-base would consist of the installation of crushed rock for leveling purposes. If present, groundwater would be tested and either pumped out to a controlled containment or discharged as would occur during trenching.

Once the vault preparation steps (excavation, shoring and finish grade leveling) are completed, setting the vault is performed via sectional lifts of the three vault pre-cast sections using either a hydraulic or a lattice type crane. With all sections of the vault set in place, backfilling can start as the shoring is removed.

Lane closures would be required at each vault location according to the following sequence:

1. Vault installation would be a stand-alone operation performed prior to trenching/duct bank installation, which would require a 4- to 7-day lane closure period for each vault.
2. Conduit cleaning/proofing would be performed after the duct bank is completely installed and backfilled. It requires a 2-day lane closure period.
3. Cable pulling would require a 2-day lane closure period per cable phase (6 total days of lane closure).
4. Racking/splicing would require 2 to 3 days at the landing single phase vaults and 7 to 9 days at the Folsom Street three-phase vault.

While the estimated total lane closure at each vault is 20 days, conduit cleaning/proofing, cable pulling and racking/splicing can only be sequential for a total of 13 days sustained closure at a single vault location.

The major equipment required for vault installation would consist of an excavator, pickup trucks, end dump trucks, stake trucks for material, 75-ton crane, crane riggers truck, tractor trailers for sheet piling delivery, tractor trailers for delivery of precast concrete manhole sections, and possibly water trucks and/or containment water tanks (see also Section 4.11.9).

4.11.5.3 Cable Pulling, Splicing, and Termination

The proposed cable system would consist of three major components: the cable, splices that connect cable sections, and terminators that connect the cable to the equipment at the substations. Cable installation would occur after the underground vaults, duct banks and HDDs are installed.

Cable Pulling

The cable for the Proposed Project would consist of three individual cables (one per electrical phase) and a communication fiber optic cable. Pulling between two vaults typically would take approximately 2 to 3 days, working 10 hours per day. To pull each cable through the duct bank, a cable reel would be placed at the end of a duct bank section in a vault, and a pulling rig would be placed at the other end of the duct bank section in another vault. With a small rope called a “fish line,” a larger rope would be pulled into the duct. The large rope would be attached to pulling eyes on a conductor end, and the large rope would pull the conductor into the duct. To ease pulling tensions, a lubricant would be applied to the conductor as it enters the duct. The three electric phases and one communication cable would be pulled through their individual ducts at the rate of two of the three sections between vaults per day.

Cable Splicing

Prior to starting the actual splicing, the vaults would be outfitted with steel racks that would ensure the cable splices are securely affixed to the vault’s inner walls. A splice trailer would be positioned adjacent to the vault manhole openings, and a mobile power generator would be located directly behind the trailer. The vaults must be kept dry twenty four hours per day to prevent water or impurities contamination of the unfinished splices. Racking and splicing is estimated to take 2 to 3 days at each landing single-phase vault and 7 to 9 days at the Folsom Street three-phase vault.

Cable Termination

At the southern end of the route, the cable would continue underground into the new Potrero 230 kV Switchyard building basement where it would terminate. At the northern end of the route, the cable would continue underground into the building of the Embarcadero 230 kV Bus Upgrade. Terminating the cable at the substations would take approximately 7 days at each end.

4.11.5.4 Jack and Bore or Microtunneling Construction

Jack and bore or microtunneling construction methods would be used if traditional open trenching cannot be used or existing utilities must be avoided in certain underground locations. Where the submarine to underground transition occurs, the trenchless construction method would be HDD, as described further in Section 4.11.7.3, Submarine to Land Transitions.

If a jack and bore segment must be used for a segment of underground cable installation, a casing would be advanced into the soil while the soils are removed by an auger rotating inside the casing. A steel casing would be used initially while the hole is being drilled to be replaced by a final casing. To minimize power losses from magnetic induction, the final casing would normally be made of nonmagnetic materials such as a fiberglass-reinforced polymer mortar. The internal PVC conduits would then be installed in the casing using plastic spacers to keep the conduits separated. The annular space between conduits and casing would then be filled with thermal grout.

Microtunneling would use a remotely controlled boring machine combined with the pipe jacking technique to directly install cable underground as an alternative to avoid having long stretches of open trench. Typical microtunnel equipment would include the boring machine, a hydraulic jacking system to jack the conduit, a closed loop slurry system to remove the excavated tunnel spoil, a slurry cleaning system to remove the spoil from the slurry water, a lubrication system for the exterior of the conduit during installation, and a guidance system to provide installation accuracy.

4.11.6 Substation and Switchyard Construction

4.11.6.1 Potrero Switchyard

Potrero Site Preparation

Activities needed to prepare the Potrero Switchyard for construction of the new 230 kV switchyard and 230/115 kV substation would include contractor equipment and personnel mobilization, utility locations, surveys, and similar construction support. Construction areas would be delineated, including the affected portions of the [GenOn-NRG](#) site, the existing switchyard, and the staging area. Public safety systems (fencing, signage, etc.) would be put in place as part of final preparations before beginning construction work.

Soil contamination is known to exist at the proposed switchyard location. The extent of soil removal necessary would be determined prior to mobilization, with the preliminary estimate being less than 8,000 cy for this site. Excavation, soil export, and import activities would be completed before below-grade construction activities begin. Adequate laydown space would be prepared to receive materials required for initial construction activities at the [GenOn-NRG](#) site and at the staging areas (see Section 4.11.3).

Potrero 230 kV Switchyard Building and Perimeter Fencing

Developing the switchyard building and completing the basement would involve constructing the building and developing site access on 23rd Street. The new switchyard would be prepared for the installation of the transformers and shunt reactor.

Preliminary foundation evaluation by PG&E suggests deep-foundation systems may be needed for some of the structures within the proposed Potrero 230 kV Switchyard, including the GIS building (PG&E, 2013a). Construction of the GIS building basement and its foundation system may require sloped-excavation or earth-retention around the perimeter of the basement excavation. Final determination would be made after the geotechnical investigation. If an earth-retention system is required for basement construction, vertical elements of the following types may be used: drilled or inserted soldier beams and timber lagging; continuous drilled piers (tangent or secant); or sheet piles. Determination of shoring type would be highly dependent on subsurface materials encountered during the geotechnical investigation and the depth of groundwater (PG&E, 2013a).

The foundation support at the new Potrero 230 kV Switchyard, including sheet piles or any other vertical elements, would be built using a non-pile (hammer) driving method, such as the Tubex grout injection method. The Tubex grout injection method uses a drill table to force a pile into the ground, then grout is injected under high pressure into the soil, a reinforcing cage or dowels are placed, and the pile is filled with concrete. This method minimizes vibration and noise, and no soil removal would be required for installing the foundation support, since the grout would be injected into the native soil. Design and final selection of these elements would be based on both the final geotechnical recommendations and the results of competitive bidding by specialty contractors qualified to perform shoring installation.

Interconnection of the 115 kV/230 kV System

Following development of the new switchyard building, PG&E would establish a new 115 kV connection between the new 230 kV switchyard and the existing Potrero Switchyard. A duct bank would be constructed from the new switchyard building to the two existing 115 kV buses at the south end of the existing Potrero Switchyard. The work would require coordination with existing underground features inside the switchyard property.

Existing Potrero Switchyard Modifications

Modifications to the existing Potrero Switchyard would include installing six tubular steel termination poles to transition the 115 kV cables from the new switchyard and duct bank and to connect to the existing 115 kV buses. Relocation of existing circuit breakers and other equipment would be necessary to secure adequate space to install new high voltage cable terminations, switches, and related structures.

Equipment Installation and Testing

Equipment installation would begin following completion of the switchyard building. The conceptual building design would provide for multiple installation functions to proceed concurrently. Cabling and equipment testing could take place alongside assembly work. Much of the cable installation work at the switchyard building would take place in the basement vault beneath the equipment.

Cable Connection, Energizing, and Commissioning

With the previous steps complete, the new 230 kV cables would then be connected into the new switchyard and substation equipment. Energizing and final testing would then take place. Immediately following termination and testing, the cables may be energized and final switchyard tests performed. The switchyard may be commissioned and tests associated with the interconnection with Potrero Switchyard completed; alternatively, in the event the Embarcadero-Potrero 230 kV cable is not available for use, 115 kV power could be sourced from Potrero Switchyard for testing the new 230 kV switchyard equipment.

Spill Prevention, Control, and Countermeasures

PG&E would prepare a Spill Prevention, Control, and Countermeasure (SPCC) Plan for the new Potrero 230 kV Switchyard, which would specifically describe the containment of equipment containing more than 50 gallons of oil. PG&E proposes local containment for the new 230 kV transformer and [shunt reactor](#). The SPCC Plan would include engineered and operational methods for preventing, containing, and controlling potential releases (e.g., construction of retention pond, moats, or berms) and provisions for quick and safe cleanup.

Depending on final hydraulic design, any collected stormwater would be either transferred by pumped pressure piping or gravity flow (surface or piped) to the existing 115 kV switchyard SPCC oil containment basin (near the intersection of Illinois and 23rd Streets), or after provisions for oil/water separation, directly into the stormwater collection system at the new 230 kV switchyard. Small amounts of additional temporary water storage (500 to 1,000 gallons) may be used as part of the water transference system from the new 230 kV switchyard area to the existing 115 kV switchyard area.

4.11.6.2 Embarcadero Substation

Since the connections at Embarcadero Substation would be made into either the existing structure or the upgraded 230 kV bus, the proposed work would only involve cable connection, energizing, and commissioning. The underground cable would be brought directly into the cable connection point of the gas insulated switchgear of the upgraded bus at Embarcadero Substation. The new 230 kV cable would then be connected into the new substation equipment. Energizing and final testing would take place, and immediately following termination and testing, the cable could be placed into service.

4.11.7 Submarine Cable Installation

The cables would be installed into the bottom sediments of the San Francisco Bay by hydroplow or other similar cable-burying technique, at a depth varying from approximately 6 to 10 feet below the floor of the bay. The Proposed Project would use a hydroplow that is pulled along the seabed behind a barge, as illustrated in Figure 4-17.

4.11.7.1 Submarine Cable Installation Procedures

The transmission cables would be buried, where feasible, a minimum of 6 feet under the surface of the sediments to protect the cables from mechanical damage. The hydroplow barge would typically be pulled into position via two commercial tugboats, and the barge anchors would be positioned to allow the barge to kedge between them along the cable route. Keding is a process by which a ship is moved slowly along the surface of the water towards the fixed point of the anchor. Once in position, the moored barge would be propelled via two diesel engines — one for steering, the other for keding anchor.

The barge would tow the hydroplow, a water jet that consists of a long blade mounted to either a sled- or tire-mounted submerged vehicle. The hydroplow blade contains water nozzles on the leading edge that displace the sediment using high-pressure water. PG&E proposes to use a hydroplow with low pressure water jets that would generally be engaged below the seabed, which would act to attenuate or dampen noise generated by the water jets and to minimize the underwater noise (PG&E, 2013a). Deck-mounted water pumps take water from the bay to the plow for jetting; the pumps draft water from a vertical suction line that is set from the barge approximately 3 feet below the surface. The intake line would be equipped with a wire-mesh screen to screen debris and reduce potential entrainment.

Each submarine cable for the transmission line would be fed from the barge down to the seabed through the blade and would exit at the foot of the blade to be laid directly into the sea bottom sediments. The length and angle of the blade would determine the burial depth of the cable. As the blade moves forward and the cable is placed in the momentarily opened trench, the majority of the fluidized sediments behind the blade fall back into the trench, effectively burying the cable. PG&E proposes to use this cable-laying method as a means of avoiding environmental disturbance that could otherwise occur through traditional mechanical trenching methods. The cable laying process is expected to require 24 to 36 hours of plowing time for each of the three cables, with 1 day needed before and after the hydroplowing to mobilize and demobilize. A team of approximately 21 people would be needed in-water and at the project site to perform the installation.

4.11.7.2 Alternative Submarine Cable Installation Procedures

PG&E developed the submarine cable route as part of a preliminary design to avoid known rocky soil conditions and any existing buried cables so that the proposed three submarine cables would be buried by hydroplow for their entire lengths. Nonetheless, either rocky soil conditions, ~~or~~ existing (but unknown) cables crossing the route, or other seismic safety design considerations may not ~~physically~~ allow the cables to be buried. At these locations, the cables would be laid directly on the bottom of the bay for a short distance until they can again be buried into the sediments. To protect such segments of exposed



Actual hydroplow used in Trans Bay Cable project.

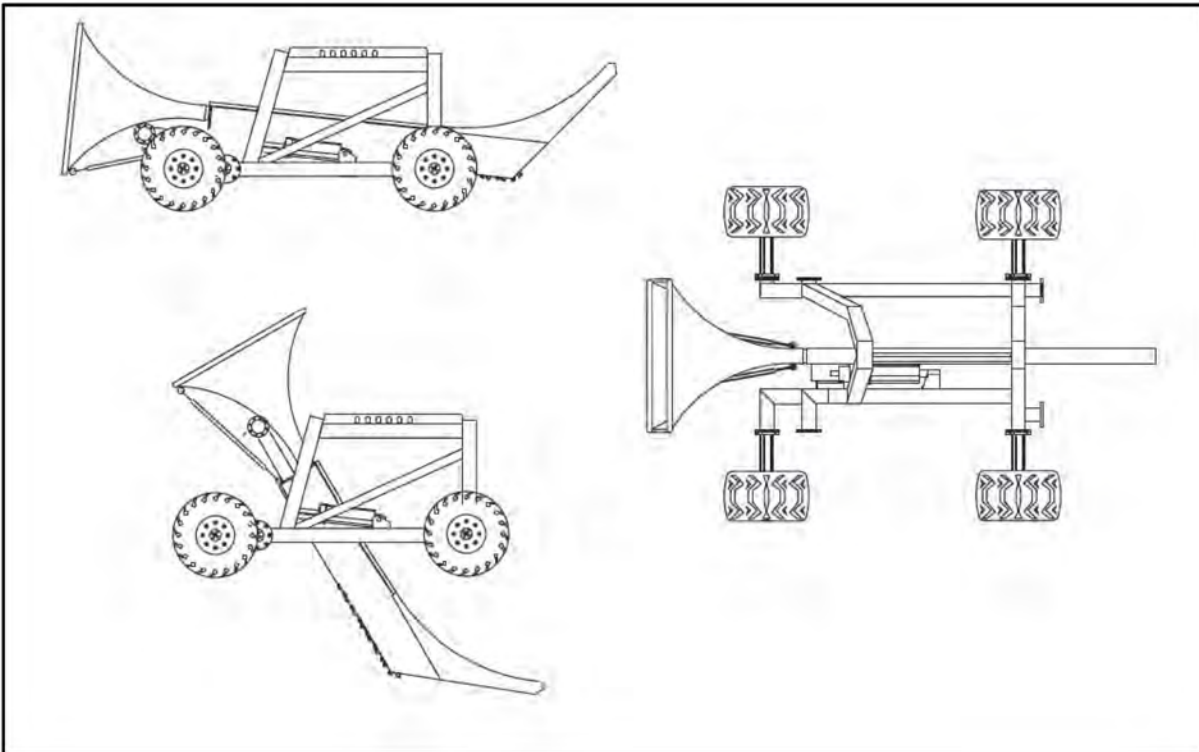

This page intentionally blank.

cable from future damage by anchors, fishing gear, etc., concrete “blankets” or steel half-pipe sections would be placed over them. Typically, this might be done for 100 feet to either side of a crossing, at 50 feet in width (200 feet by 50 feet total area). PG&E’s preliminary engineering indicates that no such blankets or pipe would be needed. Final design review prior to construction would include a review of existing conditions. However, to allow flexibility should the need arise in final design evaluations, PG&E assumes that up to 5 percent of the route, or 650 feet in length by 50 feet in width, may need to be covered by blankets or pipe on the seafloor.

4.11.7.3 Submarine to Land Transitions

Installing the submarine-to-land transition conduit would occur using shore-based HDD. PG&E proposes to use this drilling method as a means of avoiding disturbance of the shoreline. Each of the three phases of submarine cable would transition from land to water in separate HDPE conduits installed by HDD methods from the two HDD transition locations inland to exit points on the bottom of the bay. On the land side, the HDD conduit would transition to the underground duct bank conduits through a transition manhole. The submarine cable would be pulled through the conduits and spliced to a land cable type inside this vault at the onshore transitions.

The Proposed Project would use a typical HDD installation with a guided drill head to open the initial hole followed by a series of increasingly larger drill bits to bring the opening to the desired final diameter. After the hole is at the specified diameter, the internal conduits would be bundled together and pulled at one time through the hole. The detailed design of the HDD installation would be done during the final design stages.

At each landing zone, HDD operations would last for approximately 6 to 7 weeks, starting with securing the area around the HDD pit, which generally includes closing one lane and closing street parking at least on one side. PG&E would coordinate construction with DHL at the southern transition along 23rd Street or its extension into the DHL facility to ensure continued commercial access during construction.

Work would include the following steps:

- Excavating the HDD entry pit and inserting the HDD rig.
- Drilling the HDD bore holes.
- Excavating an adjacent exit (receiving) pit at the exit of the bore hole to capture mud, which would be pumped up to a barge and disposed of per appropriate regulations.
- Pulling fused sections of HDPE pipe as conduit into the bore holes.
- Connecting the ends of HDPE pipes into the transition splice vaults.
- Pulling the submarine cables back through the HDPE pipes and then into the splice vaults.
- Splicing the submarine cable to the underground land cable in the splice vaults.
- Restoring the area to pre-construction conditions.

The horizontal drilling rig and support equipment would be rigged up within the available temporary workspace. Plastic sheeting would be placed under the drill rig and any support equipment that could have a potential for a hydraulic, fuel, or oil leak. Silt fencing, erosion control, and spill containment would also be provided around the drilling equipment in order to ensure no run-off would leave from the site. A temporary chain link fence would be installed around all of the drilling equipment.

Prior to the drill reaching the underwater exit, the fluids would be circulated through the HDD back to the drill rig and collected and cleaned for reuse. Before the end of the drilling operation, the HDD exit

location would be identified and a localized excavation would be made in the seafloor sediments at the exit point to receive the heavy drilling fluids when the pilot hole is exited and during the pipe pulling operations.

At the proposed northern landing zone in Spear Street, the HDD entry points and final path would be determined during final design. Excavation for the HDD pit would likely occur within approximately 700 feet from the shoreline, and the drill would continue approximately another 1,000 to 2,300 feet to the exit point at the bottom of the bay floor. The HDD would transition to a depth of up to approximately 150 feet below ground, and would need to be at least 50 feet deep to pass below both the sewer transport/storage box under The Embarcadero and the seawall between Piers 28 and 30/32. This path would be above the bedrock layer, below the piles that support the seawall, and primarily within Colma Formation clayey sand deposits and bay muds (Figure 4-11). This drill path would also be a sufficient distance away from the steep offshore slope, permitting a smooth transition to direct burial of the cable within the bay floor.

At the proposed southern landing zone in 23rd Street, the HDD would begin at entry points and follow a path to be determined during final design. Excavation for the HDD pit would occur within the HDD entry pits and splice vault work zone depicted on Figure 4-9. The HDD would transition to a depth of approximately 30 to 50 feet below ground level and proceed approximately another 1,000 feet to an exit point at the bottom of the bay floor. This path would stay above and close to the bedrock layer and within bay mud. No seawall or deep pile obstructions were identified by PG&E along this section of shoreline.

PG&E estimates that HDD activity and drill rig use at each of the HDD locations (north and south) would occur over 13 days per each of the three borings, for a total of 39 days total at each the northern and southern HDD landings. Each day is expected to include 10 hours of drilling, for a total of 390 hours at each transition; working 6 days per week, HDD operations would last 6 to 7 weeks. The duration of 39 days at each landing is the best estimate available to PG&E (PG&E, 2013a).

PG&E expects to include acoustical performance specifications for contractors to use silencing during HDD activities to minimize the sound levels. The precise details of lane and parking space closures in the cul-de-sac on Spear Street would depend on final design (PG&E, 2013a).

HDD Entry and Exit Pits

HDD entry pits would be up to about 5 feet wide, 8 feet long, and 6 feet deep and would be covered with steel plates during non-working hours. These pits would be used only for fluid containment before pumping the fluid to the control equipment for cleaning and re-circulation. Exit (receiving) pits in the bay would be up to about 24 feet by 12 feet long and 7 feet deep.

Excavation of entry pits would require saw cutting the asphalt and excavating with a backhoe. Receiving pits would be excavated using a clamshell dredger from a work barge anchored above the exit points. Shoring would be used for the entry (containment) pit, but no shoring would be undertaken in the exit (receiving) pits. The sides of the offshore pits would be sloped sufficiently such that shoring would not be necessary.

Pilot Hole Drilling

Pilot hole drilling would be discontinued approximately 50 to 75 feet away from the exit point, to leave a “plug” of soil between the drilled hole and the sea floor. At that location, the drill pipe would be “tripped” out of the hole and the hole would be forward-reamed to a diameter of about 20 inches (assuming a 14-inch outside diameter HDPE conduit).

Following the pilot hole, reaming tools may be used to enlarge the opening to accept the proposed lines. The reaming tools are generally attached to the drill string at the exit point of the pilot hole and then rotated and drawn back to the drilling rig, thus progressively enlarging the pilot hole with each pass. During this process, drilling fluid typically consisting of bentonite clay and water would be continuously pumped into the hole to remove cuttings and maintain the integrity of the hole.

Reaming would be followed by “swabbing” to test the condition of the hole. Drilling fluids would be pumped into the hole during both of these operations. As a result of leaving the 50-foot to 75-foot plug in the bottom of the hole, all drilling fluids used during these processes would flow back to the entry point through the bore-hole annulus for re-circulating.

Pullback of Pipe, Conduit, and Cable

After swabbing the hole, the final 50 feet to 75 feet would be exited to the sea floor at which time some fluids would drain into the exit pits and containment sump. Once the hole has been sufficiently enlarged, the HDPE conduit and line would be attached behind the reaming tool on the exit side of the crossing and pulled back through the drill hole toward the drill rig, completing the crossing.

The pipe and casing of the HDPE conduit would be assembled and fused at the work area onshore within 23rd Street shown on Figure 4-9 (Potrero HDD Transition Area). Since the pipe would be a lightweight and durable conduit for the cable, it would be connected to a small boat and dragged until the pipe is floating on the water. Using the same boat, the conduit would then be tugged along the surface of the water to the area of each HDD exit (PG&E, 2013a).

The HDPE pipe would be floated into place, the front end sunk and hooked up to the drill pipe, and the pullback would proceed. Detailed construction plans to be completed by the HDD contractor would specify whether or not part of the HDPE conduit would be rested on a barge to help guide it into the bore opening, or whether the pipe would simply be submerged to the bore opening from the surface of the water. As the pipe is pulled into the drilled hole, it would displace its volume of drilling fluids to the exit pit and containment sump for approximately half the length of the pipeline, at which time the flow would begin to turn around to the entry pit where it would be contained in frac tanks for either re-use or disposal. In addition to the displacement volume, additional drilling fluid would be pumped during the pullback and would flow to the exit containment sump.

Divers would attach the HDPE conduit and submarine cable to the end of the HDD, and the cable would be pulled back onshore; see Figure 4-18. After installation of the cable, divers would pump these fluids into tanks on the barge for transfer by vacuum trucks to an approved disposal site.

Pumps would not be expected to run continuously. Pumps for drilling fluids would only operate when drilling occurs and would not operate when pull back occurs. Pull-back could potentially require over-night work should pull-back necessitate prolonged work hours. If soil conditions are such that the integrity of the hole cannot be readily maintained with daytime only activities, HDD operations would have to proceed on a 24-hour basis (PG&E, 2013a).

4.11.8 Construction Phasing

The timeline for construction and testing would be 22 months with initiation of service targeted for December 2015. The transmission line would require 15 months of work (September 2014 to December 2015), and this would overlap with 22 months of work (February 2014 to December 2015) for development of the Potrero 230 kV Switchyard. The preliminary schedule, including two to three months for additional permitting, is shown in Table 4-3.

| Table 4-3. Preliminary Proposed Construction Schedule | | | | | | | | | | | | | | | | | | | | | | | | | |
|--|----------|----------|----------|----------|----------|----------|----------|----------|----------|----------|----------|----------|----------|----------|----------|----------|----------|----------|----------|----------|----------|----------|----------|----------|----------|
| | Dec 2013 | Jan 2014 | Feb 2014 | Mar 2014 | Apr 2014 | May 2014 | Jun 2014 | Jul 2014 | Aug 2014 | Sep 2014 | Oct 2014 | Nov 2014 | Dec 2014 | Jan 2015 | Feb 2015 | Mar 2015 | Apr 2015 | May 2015 | Jun 2015 | Jul 2015 | Aug 2015 | Sep 2015 | Oct 2015 | Nov 2015 | Dec 2015 |
| Transmission Line Construction | | | | | | | | | | | | | | | | | | | | | | | | | |
| Permitting, ROW Acquisition | X | X | X | X | X | X | X | X | X | X | | | | | | | | | | | | | | | |
| Onshore Underground Installation | | | | | | | | | | X | X | X | X | X | X | X | X | | | | | | | | |
| Offshore to Onshore HDD Transition | | | | | | | | | | | X | X | X | X | X | X | X | X | | | | | | | |
| Offshore Submarine Installation | | | | | | | | | | | | | | | | | | | X | X | X | X | X | X | |
| Testing and Commissioning | | | | | | | | | | | | | | | | | | | | | | | | | X |
| Potrero Switchyard Development | | | | | | | | | | | | | | | | | | | | | | | | | |
| Switchyard Site Preparation | | | X | X | X | X | X | | | | | | | | | | | | | | | | | | |
| Building Construction | | | | | | | X | X | X | X | X | X | X | X | X | | | | | | | | | | |
| Substation Interconnection | | | | | | | | | | | X | X | X | X | X | X | | | | | | | | | |
| Substation Installation | | | | | | | | | | | | | X | X | X | X | X | X | X | X | X | X | X | X | |
| Testing and Commissioning | | | | | | | | | | | | | | | | | | | | | | | | | X |
| In-Service Date | | | | | | | | | | | | | | | | | | | | | | | | | X |

Source: Table 2-5 of PG&E, 2012a; PG&E, 2013a.
Anticipated construction hours: 10 hours per day, 5 days per week.

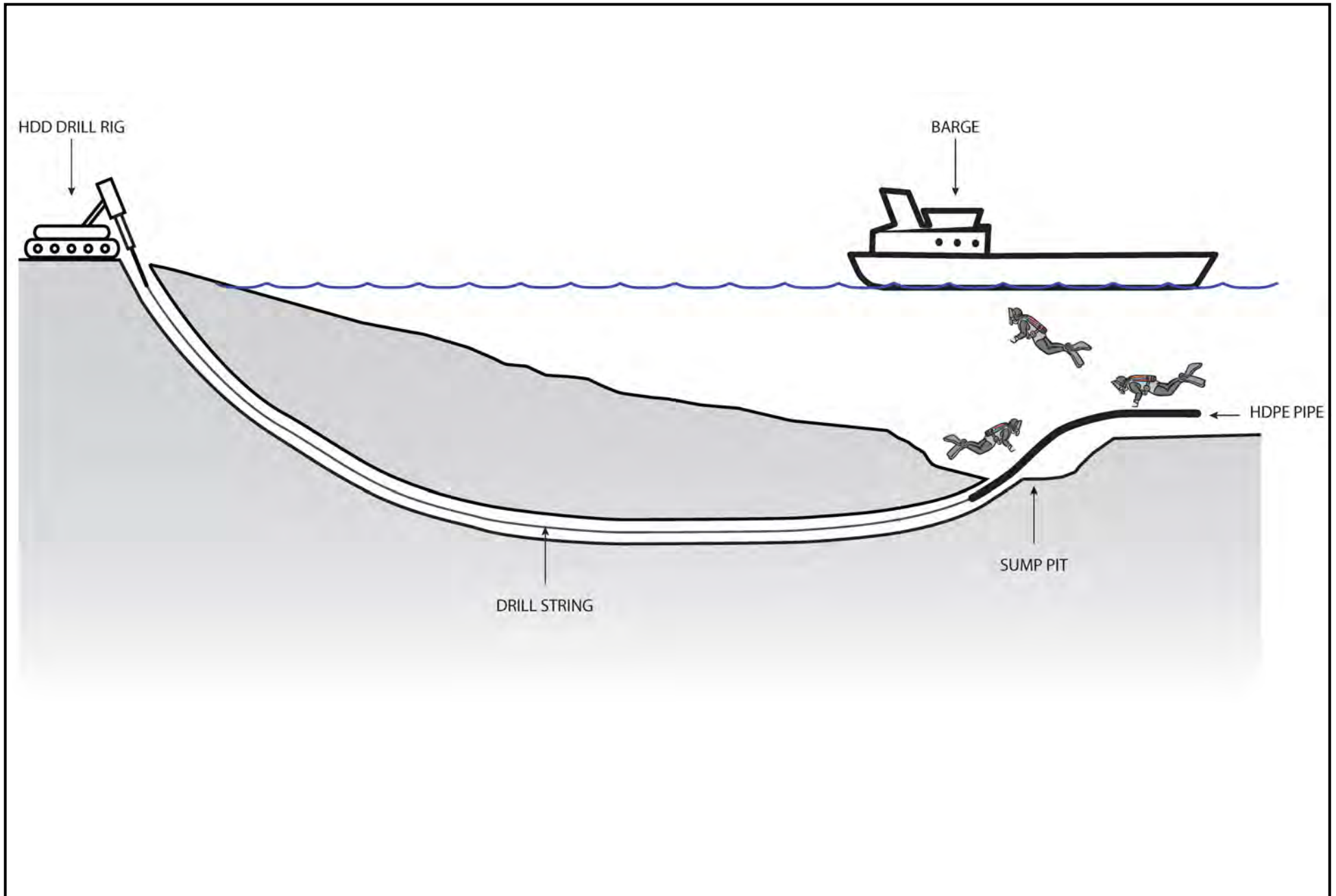

This page intentionally blank.

This preliminary schedule in Table 4-3 includes the construction of the onshore underground transmission line sections from substations to submarine cable ends; HDD construction for the submarine cable landing; submarine cable transportation and installation; and overall cable system testing and commissioning. The duration also conservatively includes hydroplow work only during the San Francisco Central Bay dredging work windows to minimize potential impacts to marine species.

Construction hours would typically be between 7 a.m. and 8 p.m., or during times set through coordination with the City and County of San Francisco. Trenching would progress at an approximate rate of 50 feet per day, and approximately 150 feet to 300 feet of trench would be open at any one time. The total duration of trench excavation and manhole installation, not including cable pulling and HDD operations, is estimated to take approximately four months for the northern underground segment along Spear and Folsom Streets and two months for the southern underground segment on 23rd Street. If trenching work would cause potential traffic congestion, the project may require nighttime work to avoid traffic disruption.

Along the trench route in city streets, PG&E would also require 4 to 7 days for installing each vault, 2 days for conduit cleaning/proofing, 2 days for cable pulling, and 2 to 3 days for racking and splicing at the landing single phase vaults and 7 to 9 days at the Folsom Street three-phase vault. Although some work may overlap, in total, each vault location would have approximately 13 days of sustained lane closure. Work to complete the two HDD transitions, install HDPE conduit, and pullback cable would take 129 days. Final paving restoration would be scheduled after the cable is fully installed and operative; final paving would take 5 days along Spear and Folsom Streets and 2 days on 23rd Street.

4.11.9 Workforce and Equipment

Construction would involve a workforce of 15 to 75 people at any one time (pp. 5-6 of PG&E, 2012a). Approximately 30 construction personnel and approximately 8 truck drivers would be employed for excavation and conduit installation using two excavation crews. Approximately 20 construction personnel would be employed during cable installation, 15 construction personnel during the HDD installations, and 25 construction personnel during the submarine cable installation. The number of employees would peak at approximately 75 construction personnel, including switchyard workers, supervisors, and inspectors. PG&E expects to hire approximately 20 percent of its construction workforce locally (roughly 10 to 15 employees). Up to 40 round-trips (80 one-way trips) would occur for workers traveling to and from each work site daily (p. 3.16-17 of PG&E, 2012a).

PG&E would require project contractors to make a good faith effort to establish a local hiring plan in collaboration with PG&E and City Build, a City of San Francisco agency created to develop local jobs and hiring in the City. Equipment expected to be used during project construction is summarized in Table 4-4.

Table 4-4. Equipment Expected to be Used During Construction

| Equipment | Quantity | Use | Expected Duration of Use |
|--|----------|--|--------------------------|
| Underground Delivery and Set-Up | | | |
| Rigging truck | 1 | Underground Transmission Line Delivery and Setup, manhole installation | 40 days |
| Mechanics truck | 1 | Equipment repair | As needed only |
| Small mobile crane | 1 | Underground duct bank installation delivery and setup | 4 months |
| Shop van | 2 | Cable splice | 1 month |
| 2-ton flatbed truck | 1 | Conduit installation | 4 months |

Table 4-4. Equipment Expected to be Used During Construction

| Equipment | Quantity | Use | Expected Duration of Use |
|--|------------------------|---|--------------------------|
| Underground Transmission Line and Switchyard Construction | | | |
| Pickup trucks | 4 to 10 | Transport construction personnel | 8 months |
| 2-ton flatbed truck | 2 | Haul materials | 6 months |
| Flatbed boom truck | 2 | Haul and unload materials | 6 months |
| Rigging truck | 1 | Haul tools and equipment | 6 months |
| Mechanic truck | 1 | Service and repair equipment | As needed only |
| Winch truck | 1 | Install and pull rope into position in conduits | 22 days |
| Cable puller truck | 1 | Pull transmission cables through conduits | 22 days |
| Cement trucks | 2 | Transport and pour backfill slurry | 4 months |
| Shop vans | 2 | Store tools | 8 months |
| Crawler backhoe | 2 | Excavate trenches (excavate around obstructions) | 4 months |
| Large backhoe | 2 | Excavate trenches (main trencher) | 4 months |
| Dump trucks | 4 | Haul trench and excavation materials/import backfill | 6 months |
| Large mobile crane (75-ton) | 1-2 | Lift/load/set 20-ton cable reels and prefabricated 40-ton splice vaults and lift cable ends on terminating structures | 22 days |
| Small mobile cranes (<12 tons) | 2 | Load and unload materials | 22 days |
| Cable reel trailers | 2 | Transport cable reels and feed cables into conduits | 22 days |
| Splice trailer (40-foot) | 1 | Splicing supplies for cable splice/air condition manholes | 40 days |
| Air compressors | Variable | Operate air tools | 3 months |
| Air tampers | Variable | Compact soil | 6 months |
| Rollers | 1 | Repave streets over trench and manhole locations | 6 months |
| Paver | 1 | Repave streets over trench and manhole locations | 6 months |
| Portable generators | 1-3 | Construction power | 8 months |
| Horizontal Directional Drill equipment | 1 | For horizontal bores by HDD | 3 months |
| Baker (water) storage tanks | As needed | Store water pumped from trenches, if needed | 4 months |
| Pumps | As needed | Remove water from trench, if needed | 4 months |
| Shoring boxes | Variable | Maintain trench walls, prevent collapse of loose soils or sand | 6 months |
| Tank trucks | As needed | Transport water from Baker tanks, to process/disposal facility | 6 months |
| Submarine Cable Installation | | | |
| Small motor harbor craft | 3 | Cable Laying (22 days) | 22 days |
| Cable laying barge | 1 | Hydroplow guide | 22 days |
| Tug or other vessel | 1 to 2 intermittent | To position barge | Intermittent, 22 days |

Table 4-4. Equipment Expected to be Used During Construction

| Equipment | Quantity | Use | Expected Duration of Use |
|--|---------------------|--|--------------------------|
| Submarine to Land Transitions (HDD Transitions) | | | |
| Small motor harbor craft | 2 | HDD Operation, for moving people, conduit, and as safety watch | 129 days |
| Barge | 1 | To serve as work platform during HDD operation, with generator to power drilling mud vacuum and other tools, including clamshell dredger | 129 days |
| Tug or other vessel | 1 to 2 intermittent | To position barge during HDD operation | Intermittent, 22 days |

Source: Table 2-4 of PG&E, 2012a; PG&E, 2013a.

4.12 Operation and Maintenance

Once the project is built and energized, PG&E’s existing local maintenance and operations group would assume monitoring and control duties and maintenance, inspection, and security roles, as needed, with support from a marine contractor. Aside from contracted stand-by marine transportation and technical support, no additional staff would be hired by PG&E after the transmission project is energized and placed into service.

Monitoring and control functions for the new facilities would be connected to the existing PG&E computer system by telecommunications. Regular inspection of transmission lines, substations, instrumentation and control, and support systems is critical for safe, efficient, and economical operation. Early identification of items needing maintenance, repair, or replacement would ensure continued safe operation of the project. Aboveground components would be inspected at least annually for corrosion, equipment misalignment, loose fittings, and other common mechanical problems. The underground portion of the line would be inspected regularly from inside the vaults to avoid disturbing traffic using city streets (Section 2.8 of PG&E, 2012a).

Routine inspection of the underground terminals would occur every three months, and detailed video and infrared inspection of vaults, splices, and terminals would occur every two years. A Distributed Temperature Sensing system of fiber optics integrated in the body of the cable would be used to monitor the submarine and underground cable.

4.12.1 Submarine Cable

Recording on Maritime Maps

Once the submarine cables are installed they would be recorded by the Coast Guard and given to NOAA for publication. PG&E would publish a Local Notice to Mariners (LNM) via Coast Guard District 11. This would provide advisory to the San Francisco Vessel Traffic Service (VTS) to allow the management of waterway traffic over VHF-FM Channel 14 requiring transit through the project location.

Surveying and Maritime Alert System

PG&E intends to conduct marine surveys at regular intervals after cable installation to assess whether potential seabed topography changes have occurred along the cable route. A cable-tracking system may be deployed as part of the route survey to confirm cable burial depth.

Besides promoting the new cable awareness and engaging stakeholders by registering the new cable on navigational maps, PG&E intends to implement an operation and maintenance strategy that would include an automatic identification system (AIS) vessel monitoring to ensure the new cable security. The system would use live vessel position in conjunction with the cable location information to create automatic warnings if the cable is at risk due to abnormal shipping activities such as vessels that are off-course or moving at unusual speed.

4.13 Applicant Proposed Measures

PG&E proposes to implement certain measures to ensure the Proposed Project would occur with minimal environmental impacts in a manner consistent with applicable rules and regulations. PG&E proposes to implement these measures during the design, construction, and operation of the Proposed Project in order to avoid or minimize potential environmental impacts (PG&E, 2012a; PG&E, 2013a).

Applicant Proposed Measures (APMs) listed in Table 4-5 are considered part of the Proposed Project and are considered in the evaluation of environmental impacts (see Section 5, Initial Study). CPUC approval would be based upon PG&E adhering to the Proposed Project as described in this document, including this project description and the APMs, as well as any adopted mitigation measures identified by this Initial Study.

Table 4-5 lists each APM by environmental issue area. In some cases, mitigation measures presented in Section 5 either expand upon or add detail to the APMs presented in Table 4-5 if necessary, to ensure that potential impacts would be reduced to less than significant levels.

Table 4-5. Applicant Proposed Measures (APMs)

| APM Number | Issue Area |
|--|--|
| Aesthetics | |
| APM AE-1 | Nighttime Lighting to Minimize Potential Visual Impacts. The new switchyard may include outdoor lighting for safety and security purposes. Design and layout for new outdoor lighting at the switchyard will incorporate measures, such as use of non-glare or hooded fixtures and directional lighting, to reduce spillover into areas outside the switchyard site and minimize the visibility of lighting from offsite locations. The new lighting will be operated only as needed and will be designed to avoid casting light or glare offsite. |
| Agricultural and Forestry Resources | |
| There are no agricultural or forest lands in the vicinity of the project. Therefore, no Applicant Proposed Measures are included for agricultural resources. | |
| Air Quality | |
| APM AQ-1 | <p>Minimize Fugitive Dust. Consistent with Table 2 of the [1999] BAAQMD CEQA Guidelines, PG&E will minimize dust emissions during construction by implementing the following measures:</p> <ul style="list-style-type: none"> ▪ Water all active construction areas at least twice daily. ▪ Cover all trucks hauling soil, sand, and other loose materials or require all trucks to maintain at least two feet of freeboard. ▪ Pave, apply water three times daily, or apply (non-toxic) soil stabilizers on all unpaved access roads, parking areas, and staging areas at construction sites. ▪ Sweep daily (with water sweepers) all paved access roads, parking areas, and staging areas at construction sites. ▪ Sweep streets daily (with water sweepers) if visible soil material is carried onto adjacent public streets. ▪ Post a publicly visible sign with the telephone number and person to contact regarding dust complaints. This person will respond and take corrective action within 48 hours. The BAAQMD's phone number will also be visible to ensure compliance with applicable regulations. <p>Since these measures are consistent with the BAAQMD CEQA Guidelines, construction emissions are considered to be less than significant (BAAQMD, 1999; BAAQMD, 2012c). Note that implementation of the first measure listed above would not apply to paved areas with no exposed soil or when rains are occurring.</p> |

Table 4-5. Applicant Proposed Measures (APMs)

| | |
|-----------------|--|
| <p>APM AQ-2</p> | <p>Minimize Construction Exhaust Emissions. The following measures will be implemented during construction to further minimize the less-than-significant construction exhaust emissions:</p> <ul style="list-style-type: none"> ▪ Encourage construction workers to take public transportation to the project site where feasible. ▪ Minimize construction equipment exhaust by using low-emissions or electric construction equipment where feasible. Develop a plan demonstrating that the off-road equipment (more than 50 horsepower) to be used would achieve a project-wide fleet-average 20 percent NO_x reduction and 45 percent PM reduction compared to the most recent CARB fleet average. Acceptable options for reducing emissions include the use of late model engines, low-emission diesel products, alternative fuels, engine retrofit technology, after-treatment products, add-on devices such as particulate filters, and/or other options as such become available. ▪ Minimize unnecessary construction vehicle idling time. The ability to limit construction vehicle idling time is dependent upon the sequence of construction activities and when and where vehicles are needed or staged. Certain vehicles, such as large diesel-powered vehicles, have extended warm-up times following start-up that limit their availability for use following start-up. Where such diesel-powered vehicles are required for repetitive construction tasks, these vehicles may require more idling time. The project will apply a "common sense" approach to vehicle use, such that idling is reduced as far as possible below the maximum of five consecutive minutes required by regulation (13 CCR 2485). If a vehicle is not required for use immediately or continuously for construction activities or other safety-related reasons, its engine will be shut off. ▪ Minimize welding and cutting by using compression or mechanical applications where practical and within standards. ▪ Encourage use of natural gas or electric powered vehicles for passenger cars and light-duty trucks where feasible and available. |
| <p>APM AQ-3</p> | <p>Minimize Potential Naturally Occurring Asbestos (NOA) Emissions. The following measures will be implemented prior to and during construction to minimize the potential for NOA emissions:</p> <ul style="list-style-type: none"> ▪ Prior to commencement of construction, samples of the Potrero Switchyard construction area will be analyzed for presence of asbestos, serpentinite or ultramafic rock ▪ If asbestos, serpentinite or ultramafic rock is determined to be present, implement all applicable provisions of the Airborne Toxic Control Measure (ATCM) for Construction, Grading, Quarrying and Surface Mining Operations (17 CCR 93105), including: <ul style="list-style-type: none"> <i>For disturbed areas of 1.0 acre or less:</i> <ul style="list-style-type: none"> – Construction vehicle speed at the work site will be limited to 15 miles per hour or less – Prior to any ground disturbance, sufficient water will be applied to the area to be disturbed to prevent visible emissions from crossing the property line – Areas to be graded or excavated will be kept adequately wetted to prevent visible emissions from crossing the property line – Storage piles will be kept adequately wetted, treated with a chemical dust suppressant, or covered when material is not being added to or removed from the pile – Equipment will be washed down before moving from the property onto a paved public road – Visible track-out on the paved public road will be cleaned using wet sweeping or a High Efficiency Particular Air filter equipped vacuum device within 24 hours <i>For disturbed areas of greater than 1.0 acre:</i> <ul style="list-style-type: none"> – Submit an Asbestos Dust Mitigation Plan to the BAAQMD and obtain approval prior to commencement of construction – Implement and maintain the provisions of the approved Asbestos Dust Mitigation Plan from the beginning of construction through the duration of the construction activity |

Table 4-5. Applicant Proposed Measures (APMs)

| Biological Resources | |
|----------------------|---|
| APM BIO-1 | <p>General Measures. Environmental awareness training will be conducted for onsite construction personnel prior to the start of construction activities. The training will explain the APMs and any other measures developed to prevent impacts on special-status species, including nesting birds. The training will also include a description of special-status species and their habitat needs, as well as an explanation of the status of these species and their protection under the ESA, CESA, and other statutes. A brochure will be provided with color photos of sensitive species, as well as a discussion of any permit measures. A copy of the training and brochure will be provided to CPUC at least 30 days prior to the start of construction for project files. This APM also includes the following measures:</p> <ul style="list-style-type: none"> ▪ Biological monitor: A qualified biological monitor will verify implementation and compliance with all applicant proposed measures. The monitor will have the authority to stop work or determine alternative work practices where safe to do so, as appropriate, if construction activities are likely to impact sensitive biological resources. ▪ Litter and trash management: All food scraps, wrappers, food containers, cans, bottles, and other trash from the project area will be deposited in closed trash containers. Trash containers will be removed from the project area at the end of each working day. ▪ Parking: Vehicles and equipment will be parked on pavement, existing roads, and previously disturbed or developed areas or work areas as identified in this document. ▪ Pets and firearms: No pets or firearms will be permitted at the project site. |
| APM BIO-2 | <p>Preconstruction Surveys. Preconstruction bird nesting surveys will be conducted in the project area no more than 15 days before work is performed in the nesting season February 1 to August 15. Surveyors will search for all potential nest types (e.g. ground, cavity, shrub/tree, structural, etc.) and determine whether or not the nest is active. A nest will be determined to be active if eggs or young are present in the nest. Upon discovery of active nests, appropriate minimization measures (e.g., buffers or shielding) will be determined and approved by the biologist. PG&E's biological monitor will determine the use of a buffer or shield and work may proceed based upon: acclimation of the species or individual to disturbance, nest type (cavity, tree, ground, etc.), and level and duration of construction activity.</p> <p>In the unlikely event a listed species is found nesting nearby in this urban environment, CDFG and USFWS will be notified if a nest of a listed species is identified in the area of analysis, and the CPUC will be provided with nest survey results, if requested. When active nests are identified, monitoring for significant disturbance to the birds will be implemented.</p> <p>Nest checks will occur each day construction is occurring, documented in a nest check form to be included in the Worker's Environmental Awareness Training package. Typically a nest check will have a minimum duration of 30 minutes, but may be longer or shorter, or more frequent than one check per day, as determined by PG&E's biological monitor based on the type of construction activity (duration, equipment being used, potential for construction-related disturbance) and other factors related to assessment of nest disturbance (weather variations, pair behavior, nest stage, nest type, species, etc.). The biological monitor will record the PG&E construction activity occurring at the time of the nest check and note any work exclusion buffer in effect at the time of the nest check. Non-PG&E activities in the area should also be recorded (e.g. adjacent construction sites, roads, commercial/industrial activities, residential activities, etc.). The biological monitor will record any sign of disturbance to the active nest, including but not limited to parental alarm calls, agitated behavior, distraction displays, nest fleeing and returning, chicks falling out of the nest or chicks or eggs being predated as a result of parental abandonment of the nest. Should the PG&E biological monitor determine project activities are causing or contributing to nest disturbance that might lead to nest failure, the PG&E biological monitor will coordinate with the Construction Manager to limit the duration or location of work, and/or set other limits related to use of project vehicles, helicopters, chainsaws, and/or heavy equipment. Should PG&E's biological monitor determine that project activities are not resulting in significant disturbance to the birds, construction activity will continue and nest checks while work is occurring will be conducted periodically.</p> |
| APM BIO-3 | <p>Seasonal Work Windows. Where feasible, hydroflow cable installation will be conducted between June 1 <u>March 1</u> and November 30, based on the seasonal work windows for steelhead, Chinook salmon, and Pacific herring (USEPA et al., 1996). If work is planned to occur outside of this work window, PG&E will coordinate any additional measures, such as <u>buffer zones and</u> monitoring for herring spawn, with NMFS, USFWS, and CDFW. <u>PG&E will notify CDFW 30 days in advance of its intent to apply for an extension of the work window.</u></p> |

Table 4-5. Applicant Proposed Measures (APMs)

| | |
|---------------------------|---|
| APM BIO-4 | Herring Spawning Protection. If work occurs within the Bay in December, January, or February, a qualified observer shall monitor hydroplow and HDD connection activities when in proximity (about 660 to 980 feet, or 200 to 300 meters) to potential Pacific herring spawning sites. Herring spawning sites are generally located in shallow water near the surface, and are visible as a large mass of herring eggs, which are adhesive, and attach most commonly to eelgrass or other algae, and can also attach to piers and other features; no eelgrass beds occur in the work areas. If herring spawning sites are observed within 660 feet (200 meters) of the work site by a qualified monitor stationed on a nearby boat, pier, or beach, all in-water activities such as hydroplowing shall be stopped within that distance or as otherwise specified by the resource agencies for 2 weeks. |
| APM BIO-5 | Aquatic Habitat Protection. PG&E will acquire the necessary permits to conduct cable installation activities in the San Francisco Bay. PG&E will comply with all conditions and requirements of these permits and certification. |
| APM BIO-6 | Fish Screen. All hydroplow water jet intakes will be covered with a mesh screen to minimize the potential for impingement or entrainment of fish species. |
| Cultural Resources | |
| APM CUL-1 | <p>Pre-Construction Worker Cultural Resources Training. Prior to construction, PG&E will design and implement a Worker Cultural Resources Training Program for all project personnel who may encounter and/or alter historical resources or unique archaeological properties. Construction supervisors, workers, and other field personnel will be required to attend the training program prior to their involvement in field operations. The program will be conducted in conjunction with other environmental awareness training and education for the project. The cultural resources training session will be led by a qualified instructor meeting the Secretary of Interior's Professional Qualification Standards as listed beginning on page 44716 of Volume 48 of the Federal Register and as may be updated by the National Park Service.</p> <p>This Program will minimally include:</p> <ul style="list-style-type: none"> ▪ A review of the environmental setting (prehistory, ethnography, history) associated with the project; ▪ A review of Native American cultural concerns and recommendations during project implementation; ▪ A review of applicable federal, state, and local laws and ordinances governing cultural resources and historic preservation; ▪ A review of what constitutes prehistoric or historical archaeological deposits and what the workers should look out for; ▪ A discussion of site avoidance requirements and procedures to be followed in the event unanticipated cultural resources are discovered during construction; ▪ A discussion of procedures to follow in the event human remains are discovered during construction; ▪ A discussion of disciplinary and other actions that could be taken against persons violating historic preservation laws and PG&E policies; ▪ A discussion of eligible and potentially eligible built environment resources and procedures to follow regarding minimizing vibration from equipment in designated areas; and ▪ A statement by the construction company or applicable employer agreeing to abide by the program conditions, PG&E policies, and applicable laws and regulations. |
| APM CUL-2 | Resource Avoidance. There are no known archaeological or historical resources within the direct impact areas defined for the proposed route. In keeping with the intent of the NHPA and CEQA, PG&E's preferred approach for archaeological resources and historical resources is avoidance of impacts to significant (or unevaluated) resources. Where avoidance is not feasible, potential impacts to significant cultural resources must be treated in a way that is acceptable to PG&E, the State Historic Preservation Officer (SHPO), and if applicable, the local Native American community. Treatment might include data recovery excavations, public interpretation/education, Historic American Buildings Survey (HABS)/Historic American Engineering Record (HAER) recordation, or other measures. If there is an unanticipated discovery of a buried archaeological deposit or human remains, or unanticipated impacts to a historical building cannot be avoided, PG&E will implement APM CUL-4, -5, and -7. |

Table 4-5. Applicant Proposed Measures (APMs)

| | |
|-----------|--|
| APM CUL-3 | <p>Construction Monitoring. A professional archaeologist meeting the Secretary of the Interior’s Professional Qualifications Standards will monitor all project-related on-shore excavation that is within an area of moderate to high sensitivity for prehistoric or historical buried resources, as such areas are presented in PEA Appendix D (Nolte et al. 2012). This shall include monitoring areas within 167 feet (50 meters) of recorded or previously identified prehistoric and historical-era sites or features, APM CUL-3 will be guided by an Archaeological Monitoring and Inadvertent Discovery Plan, which will include the framework for evaluation and treatment of any unanticipated discoveries described in APM CUL-4.</p> <p>In addition to the monitoring archaeologist, a qualified maritime archaeologist will be on call during construction to assist with implementation of the Archaeological Monitoring and Inadvertent Discovery Plan should maritime resources be identified during excavation. If appropriately qualified, the same person may act as both the monitoring archaeologist and maritime archaeologist. This APM CUL-3 in combination with APM CUL-4 will ensure that archaeological resources will not be impacted during construction without adequate evaluation and any necessary actions (as further detailed in APM CUL-4 and the Archaeological Monitoring and Inadvertent Discovery Plan) to preserve information regarding impacted resources. Site assessment procedures and data recovery or other measures will be developed as part of the Archaeological Monitoring Plan and applied during the monitoring process.</p> |
| APM CUL-4 | <p>Unanticipated Discoveries of Cultural Deposits. In the event that previously unidentified archaeological, cultural, or historical sites, artifacts, or features are uncovered during implementation of the project, work will be suspended within 100 feet (30 meters) of the find and redirected to another location. PG&E’s cultural resources specialist or designated representative will be contacted immediately to examine the discovery and determine if additional work is needed. If the discovery can be avoided or protected and no further impacts will occur, the resource will be documented on California Department of Parks and Recreation 523 forms and no further effort will be required.</p> <p>If the resource cannot be avoided and may be subjected to further impacts, PG&E or their representative will evaluate the significance of the discovery following federal and state laws outlined above and implement data recovery or other appropriate treatment measures if warranted. Evaluation of historical-period resources will be done by a qualified historical archaeologist while evaluation of prehistoric resources will be done by a qualified archaeologist specializing in California prehistoric archaeology. Evaluations may include archival research, oral interviews, and/or field excavations to determine the full depth, extent, nature, and integrity of the deposit.</p> |
| APM CUL-5 | <p>Unanticipated Discovery of Human Remains. If human remains or suspected human remains are discovered during construction, work within 100 feet of the find will stop immediately and the construction foreman shall contact the PG&E cultural resources specialist, who will then call the City and County of San Francisco Medical Examiner. There shall be no further excavation or disturbance of the site, or any nearby area reasonably suspected to overlie adjacent remains, until medical examiner has determined that the remains are not subject to provisions of Section 27491 of the Government Code. If the medical examiner determines the remains to be Native American, he/she shall contact the NAHC within 24 hours. The NAHC will appoint a Most Likely Descendent for recommendations on the treatment and disposition of the remains (Health and Safety Code Sect. 7050.5, Public Resources Code Sect. 5097.24).</p> |
| APM CUL-6 | <p>Vibrations to Historical Structures. Historical buildings are present near the project route and may be vulnerable to damage from heavy equipment vibrations. To ensure that resources are not inadvertently damaged or impacted during construction implementation, the crews will be informed of historical structure locations and instructed to confine all excavation and backfill work to the existing city streets right-of-way (historical structure locations are depicted in PEA Appendix D (Nolte et al. 2012) as part of APM-CUL-1).</p> <p>Project construction in proximity to Station A will include the use of Tubex and the smallest possible machinery to minimize vibration effects. A structural engineer will check the condition of the building prior to construction. Once activities that result in vibration have begun, the engineer will check the condition of the building to monitor Station A during construction (at 25 percent, 50 percent, 75 percent, and 100 percent completion of excavation using heavy equipment) and assess the effects on the building. If the structural engineer determines that structural integrity is compromised, the interior of the building will be documented following the procedures outlined in APM-CUL-7.</p> |

Table 4-5. Applicant Proposed Measures (APMs)

| | |
|----------------------------------|---|
| APM CUL-7 | <p>Record to Historic American Building Survey/Historic American Engineering Record Standards. Station A's setting will be affected by construction of the GIS building. The currently visible exterior façade on the west side of the main turbine building may be blocked from view, and the brick wall that fronts Station A and that serves as a visual barrier will be partially or completely removed.</p> <p>Prior to construction, the setting and exterior of the Station and brick wall will be documented using HAER standards. These standards include large format photography of the structures, photo reproduction of historical plans, mapping, and a descriptive and historical narrative. The resulting documentation will be archived with PG&E, the SHPO, the Bancroft Library at the University of California Berkeley, the San Francisco Landmarks Preservation Advisory Board files at the San Francisco Planning Department, the Foundation for San Francisco's Architectural Heritage, and the San Francisco Public Library.</p> |
| APM CUL-8 | <p>Apply Secretary of the Interior Standards for the Treatment of Historic Properties to Brick Wall Modifications. The gate in the brick wall that fronts Station A will <u>may</u> be widened and the wall removed or modified to allow access for large transformer equipment and future maintenance activities.</p> <p>Modifications to or removal of the wall will follow the Secretary of the Interior Standards for the Treatment of Historic Properties (available at http://www.nps.gov/hps/tps/standguide/) and will be designed to be compatible with the historic character of Station A. PG&E will submit a draft of its design for the brick wall modifications to the Commission no less than 30 days prior to any alteration of the wall.</p> |
| Paleontological Resources | |
| APM PR-1 | <p>Worker Environmental Awareness Program Paleontological Resources Module. The project's worker environmental awareness program, which all workers will complete prior to beginning work on the project site, will include a module on paleontological resources (fossils). The module will discuss the laws protecting paleontological resources, recognition in the field and types of paleontological resources that could be encountered on the project, and the procedures to be followed if a paleontological resource is discovered. A copy of the project's worker environmental awareness training will be provided to the CPUC for recordkeeping prior to the start of construction.</p> |
| APM PR-2 | <p>Unanticipated Paleontological Resource Discovery. If fossils are observed during excavation, work in the immediate vicinity of a paleontological find will be halted or redirected to avoid additional impact to the specimen(s), and to allow a professional paleontologist to assess the scientific importance of the find and determine appropriate treatment. If the discovery is significant, the qualified paleontologist will implement data recovery excavation to scientifically recover and curate the specimen.</p> |
| Geology and Soils | |
| APM GS-1 | <p>Appropriate soil stability design measures implementation. Based on available references, artificial fills, fine sands, silts, and bay mud are the primary soil types expected to be encountered in the excavated areas as project construction proceeds. Potentially problematic subsurface conditions may include soft or loose soils. Where soft, loose, or liquefiable soils are encountered during design studies or construction of the onshore portion of the route, appropriate measures will be implemented to avoid, accommodate, replace, or improve soft or loose soils and liquefaction hazards encountered during construction. Such measures may include the following:</p> <ul style="list-style-type: none"> ▪ Locating construction staging and operations away from areas of soft and loose soil. ▪ Over-excavating soft or loose soils and replacing them with suitable non-expansive engineered fill. ▪ Increasing the density and strength of soft or loose soils through mechanical vibration and/or compaction. ▪ Treating soft or loose soils in place with binding or cementing agents. ▪ Construction activities in areas where soft or loose soils are encountered may be scheduled for the dry season, as necessary, to allow safe and reliable equipment access. ▪ Physical ground improvement such as in-situ soil mixing, drain piles, or sheet piles. ▪ Deepening of trench and/or the HDD to place the transmission line beneath liquefiable fills and/or potential for lateral spreading, where feasible. |

Table 4-5. Applicant Proposed Measures (APMs)

| | |
|--|--|
| APM GS-2 | <p>Appropriate seismic safety design measures implementation. As part of conceptual design investigation, site-specific seismic analyses were performed to evaluate PGAs for design of project components. Because the proposed transmission cables will be lifeline utilities, the 84th percentile motions (i.e., one standard deviation above the median; see Table 3.6-2), were used (B&V 2012). The project will be designed based on current seismic design practices and guidelines. <u>Potential seismic safety design practices for onshore segments may include geotextile wrap, an oversized trench with a compressible zone, flexible joints, duct banks with heavier/high strength reinforcement, flexible conduits in place of concrete duct banks, soil improvement, or use of deep foundations; offshore segments may include flexible joints at the transition to land cables, sinusoidal installation or other methods to provide slack in the submarine cable.</u></p> |
| APM GS-3 | <p>Appropriate erosion-control measures implementation. Best Management Practices (BMPs) will be implemented to minimize and avoid surface runoff, erosion, and pollution (see APM WQ-1 and WQ-2).</p> |
| Greenhouse Gas Emissions | |
| APM GHG-1 | <p>Minimize Construction Exhaust Emissions. The following measures will be implemented during construction to further minimize the less-than-significant construction GHG emissions:</p> <ul style="list-style-type: none"> ▪ Encourage construction workers to take public transportation to the project site where feasible. ▪ Minimize construction equipment exhaust by using low-emissions or electric construction equipment where feasible. ▪ Minimize unnecessary construction vehicle idling time. The ability to limit construction vehicle idling time is dependent upon the sequence of construction activities and when and where vehicles are needed or staged. Certain vehicles, such as large diesel-powered vehicles, have extended warm-up times following start-up that limit their availability for use following start-up. Where such diesel-powered vehicles are required for repetitive construction tasks, these vehicles may require more idling time. The project will apply a “common sense” approach to vehicle use, such that idling is reduced as far as possible below the maximum of five consecutive minutes required by California regulation (13 CCR 2485). If a vehicle is not required for use immediately or continuously for construction activities, its engine will be shut off. ▪ Minimize welding and cutting by using compression or mechanical applications where practical and within standards. ▪ Encourage use of natural gas or electric powered vehicles for passenger cars and light-duty trucks where feasible and available. ▪ Encourage the recycling of construction waste where feasible. |
| APM GHG-2 | <p>Avoid and Minimize Potential SF6 Emissions. PG&E will include Potrero Switchyard in PG&E’s system-wide SF6 emission reduction program, which includes inventorying and monitoring system-wide SF6 leakage rates and employing X-ray technology to inspect internal circuit breaker components to eliminate dismantling of breakers and reduce accidental releases. New circuit breakers installed at Potrero Switchyard and Embarcadero Substation will have a manufacturer’s guaranteed SF6 leakage rate of 0.5 percent per year or less and will be maintained in accordance with PG&E’s maintenance guidelines.</p> |
| <p>In addition to these APMs, PG&E is implementing the following voluntary company-wide actions to further reduce GHG emissions:</p> <ul style="list-style-type: none"> ▪ PG&E is an active member of the SF6 Emission Reduction Partnership for Electric Power Systems, a voluntary program between the USEPA and electric power companies that focuses on reducing emissions of SF6 from transmission and distribution operations. Since 1998, PG&E has reduced its SF6 leakage rate by 89 percent and absolute SF6 emissions by 83 percent. ▪ PG&E supports Natural Gas STAR, a program promoting the reduction of CH4 from natural gas pipeline operations. Since 1998, PG&E has avoided the release of thousands of tons of CH4. ▪ On April 24th, 2012, PG&E submitted a proposal to state regulators for a new clean energy program that would give its electric customers an opportunity to support 100 percent renewable energy for an average of a few dollars a month. If approved, the “Green Option” would be totally voluntary, and customers could enroll in and/or leave the program as they wish. If approved, PG&E will buy renewable energy certificates to match the portion of each participating electric customer’s energy that is not already covered by PG&E’s eligible renewable energy deliveries. PG&E is asking the California Public Utilities Commission to approve the Green Option by early 2013. | |

Table 4-5. Applicant Proposed Measures (APMs)

| Hazards and Hazardous Materials | |
|---------------------------------|---|
| APM HM-1 | <p>Implementation of Hazardous Material and Emergency Response Procedures. PG&E will implement construction controls, training and communication to minimize the potential exposure of the public and site workers to potential hazardous materials during all phases of project construction. These construction practices include construction worker training appropriate to the site worker's role (see APM HM-3), and containment and spill control practices in accordance with the Stormwater Pollution Prevention Plan (see APM WQ-1). If it is necessary to store chemicals, they will be managed in accordance with all applicable regulations. Material safety data sheets will be maintained and kept available on site, as applicable.</p> <p>Soil that is suspected of being contaminated (on the basis of existing analytical data or visual, olfactory, or other evidence) and is removed during trenching or excavation activities will be segregated, tested, and if contaminated above hazardous levels, will be contained and disposed of offsite at a licensed waste facility. The presence of known or suspected contaminated soil will require testing and investigation procedures to be supervised by a qualified person, as appropriate, to meet state and federal regulations.</p> <p>All hazardous materials and hazardous wastes will be handled, stored, and disposed of in accordance with all applicable regulations, by personnel qualified to handle hazardous materials. Practices during construction will include, but not be limited to, the following:</p> <ul style="list-style-type: none"> ▪ Proper disposal of potentially contaminated materials. ▪ Site-specific buffers for construction vehicles and equipment located near sensitive resources/receptors. ▪ Emergency response and reporting procedures to address any potential hazardous material spills as described in PEA Section 3.9, Hydrology and Water Quality. ▪ Stopping work at that location and contacting the CUPA (SFDPH Environmental Health Section; see PEA Section 3.8.2.1 above) immediately if unanticipated visual evidence of potential contamination or chemical odors are detected. Work will be resumed at this location after any necessary consultation and approval by the CUPA or other entities as specified by the CUPA. <p>For the O&M phase of the project, existing operational hazardous substance control and emergency response plans will be updated as appropriate to incorporate necessary modifications resulting from this project. <i>(Also see APM WQ-1 and APM WQ-3 in PEA Section 3.9.4.2)</i></p> |
| APM HM-2 | <p>Development and Implementation of a Health and Safety Plan. PG&E will prepare a project-specific health and safety (H&S) plan prior to project construction. The purpose of the plan is to minimize potential safety hazards to site construction workers. The H&S plan will outline the project team H&S responsibilities; present job safety analyses, H&S procedures, and personal protective equipment requirements; establish worker training and monitoring requirements; and describe emergency response procedures relevant to project activities. Each contractor will be responsible for preparing and submitting to PG&E their own H&S Plan specific to their activities using the PG&E Plan for project-specific information.</p> <p>For the O&M phase of the project, existing H&S plans for Potrero Switchyard and Embarcadero Substation will be modified and adhered to as appropriate.</p> |
| APM HM-3 | <p>Adherence to Applicable Site-specific RMPs and SMPs. In addition to following its own project-specific procedures during the construction phase, PG&E will adhere to any applicable site-specific plans such as the SMP for the former Potrero Power Plant (see PEA Section 3.8.3.1), as well as the Maher Ordinance (see PEA Section 3.8.2.1).</p> |
| APM HM-4 | <p>Emergency Spill Supplies and Equipment. Oil-absorbent material, tarps, and storage drums will be available on the project site during construction and used to contain and control any minor releases of oil. In the event that excess water and liquid concrete escapes during pouring, it will be directed to lined and bermed areas adjacent to the borings, where the water will evaporate and the concrete will begin to set. Once the excess concrete has been allowed to set up, it will be removed and transported for disposal, according to applicable regulations. <i>(Also see APM WQ-4.)</i></p> |

Table 4-5. Applicant Proposed Measures (APMs)

| | |
|----------|---|
| APM HM-5 | <p>Soil, Groundwater, and Underground Tank Characterization. In areas where existing data are not available, soil and groundwater sampling and potholing will be conducted in onshore project areas before construction begins. Appropriate handling, transportation, and disposal locations will be determined based on results of the analyses performed on soil and groundwater. In addition, results will be provided to contractor and construction crews to inform them about soil and groundwater conditions and potential hazards. The location, distribution, and/or frequency of the borings will give adequate representation of the conditions in the construction area.</p> <p>If suspected hazardous substances are unexpectedly encountered during trenching or other construction activities (using indicators such as sheen, odor, soil discoloration), work will be stopped until the material or tank is properly characterized and appropriate measures are taken to protect human health and the environment. Appropriate personal protective equipment will be used and waste management will be performed in accordance with applicable regulations. If excavation of hazardous materials is required, the materials will be disposed of in accordance with applicable regulations. If necessary, groundwater will be collected during construction, contained, and disposed of in accordance with all applicable regulations.</p> <p>If underground or aboveground storage tanks are found to be located along the project route and the route cannot be adjusted to avoid disturbance, the tanks will be removed prior to project construction. If it is determined that removal and disposal of tanks is necessary, a separate workplan describing the proper decommissioning and removal of the tanks and removal of any associated impacted soil will be prepared prior to removal.</p> <p><i>(Also see APM WQ-5.)</i></p> |
| APM HM-6 | <p>Horizontal Directional Drilling (HDD) Drilling Fluid and Cuttings Monitoring and Management. HDD operations will include provisions for monitoring for loss of drilling fluids. Spill response measures shall include reducing fluid pressures and thickening the fluid mixture. Both the drilling technique and early detection and response shall be used to minimize release of fluids to the environment. A Frac-out Plan will be developed and prepared based on site specific conditions and specific contractor methods and equipment.</p> <p><i>(Also see APM WQ-6 and APM WQ-7.)</i></p> |
| APM HM-7 | <p>Sediment Testing Program for Submarine Cable Installation. As discussed above, sediments along the submarine cable route are located near known contaminated sediment areas (SFEI, 2012), and a Sampling and Analysis Plan will be prepared in coordination with the Dredged Material Management Office (DMMO) of the U.S. Army Corps of Engineers. Sediment sampling shall be performed at the locations where the HDD emerges into the Bay, and the results would be considered and addressed prior to commencement of construction near these locations. Potential contaminants such as PAHs and heavy metals are generally insoluble or have low solubility in water. Conducting sediment analysis of samples before the installation of the submarine cable will establish baseline conditions along the project route. The sediment testing program will be used to develop appropriate construction control measures that may include controlling turbidity during construction through adjustment of hydroplow jet controls and flows, turbidity monitoring during construction in certain areas, and appropriate handling and disposal of any sediment that may be removed as part of the submarine transitions to HDD installation.</p> <p><i>(Also see APM WQ-8.)</i></p> |

Table 4-5. Applicant Proposed Measures (APMs)

| Hydrology and Water Quality | |
|-----------------------------|--|
| APM WQ-1 | <p>Development and Implementation of a Stormwater Pollution Prevention Plan (SWPPP). Stormwater discharges associated with project construction activities are regulated under the General Construction Permit. Cases in which construction will disturb more than one acre of soil require submittal of a Notice of Intent, development of a SWPPP (both certified by the Legally Responsible Person (LRP)), periodic monitoring and inspections, retention of monitoring records, reporting of incidences of noncompliance, and submittal of annual compliance reports. PG&E will comply with all General Construction Permit requirements.</p> <p>Following project approval, PG&E will prepare and implement a SWPPP, which will address erosion and sediment control to minimize construction impacts on surface water quality. The SWPPP will be designed specifically for the hydrologic setting of the Proposed Project in proximity to the San Francisco Bay. Implementation of the SWPPP will help stabilize graded areas and reduce erosion and sedimentation. The SWPPP will designate BMPs that will be adhered to during construction activities. Erosion and sediment control BMPs, such as straw wattles, erosion control blankets, and/or silt fences, will be installed in compliance with the SWPPP and the General Construction Permit. Suitable soil stabilization BMPs will be used to protect exposed areas during construction activities, as specified in the SWPPP. During construction activities, BMPs will be in place to address construction materials and wastes.</p> <p>BMPs, where applicable, will be designed by using specific criteria from recognized BMP design guidance manuals. Erosion and sediment-minimizing efforts will include measures such as the following:</p> <ul style="list-style-type: none"> ▪ Defining ingress and egress within the project site to control track-out ▪ Implementing a dust control program during construction ▪ Properly containing stockpiled soil <p>Identified erosion and sediment control measures will be installed in an area before construction begins and inspected and improved as needed before any anticipated storm events. Temporary sediment control measures intended to minimize sediment transport from temporarily disturbed areas, such as silt fences or wattles, will remain in place until disturbed areas are stabilized. In areas where soil is to be temporarily stockpiled, soil will be placed in a controlled area and managed with similar erosion-control techniques. Where construction activities occur near a surface water body or drainage channel, the staging of construction materials and equipment and excavation spoil stockpiles will be placed at least 50 feet from the water body and properly contained, such as with berms and/or covers, to minimize risk of sediment transport to the drainage. Any surplus soil will be transported from the site and appropriately disposed of.</p> <p>A copy of the SWPPP will be provided to the CPUC for recordkeeping. The plan will be maintained and updated during construction as required by the SWRCB.</p> |
| APM WQ-2 | <p>Implementation of a Worker Environmental Awareness Program. The project's worker environmental awareness program will communicate environmental issues and appropriate work practices specific to this project to all field personnel. These will include spill prevention and response measures and proper BMP implementation. The training program will emphasize site-specific physical conditions to improve hazard prevention (such as identification of flow paths to nearest water bodies) and will include a review of all site-specific water quality requirements, applicable portions of erosion control and sediment transport BMPs contained in the SWPPP (APM WQ-1) and the health and safety plan (see APM HM-2 in PEA Section 3.8.4.2). A copy of the project's worker environmental awareness training record will be provided to the CPUC for recordkeeping. An environmental monitoring program will also be implemented to ensure that the plans are followed throughout the construction period.</p> |
| APM WQ-3 | <p>Implementation of Hazardous Material and Emergency Response Procedures. PG&E will implement construction controls, training and communication to minimize the potential exposure of the public and site workers to potential hazardous materials during all phases of project construction.</p> <p>These construction practices include construction worker training appropriate to the site worker's role (see APM HM-3), containment and spill control practices in accordance with the SWPPP (see APM WQ-1), and emergency response to ensure appropriate cleanup of accidental spills. If it is necessary to store chemicals, they will be managed in accordance with all applicable regulations. Material safety data sheets will be maintained and kept available on site, as applicable. The project SWPPP (APM WQ-1) will identify areas where refueling and vehicle-maintenance activities and storage of hazardous materials, if any, will be permitted.</p> <p><i>(Also see APM HM-1.)</i></p> |

Table 4-5. Applicant Proposed Measures (APMs)

| | |
|----------|---|
| APM WQ-4 | <p>Emergency Spill Supplies and Equipment. Materials will be available on the project site during construction to contain, collect and dispose of any minor spill (for example, absorbent material, tarps, and storage drums). In the event that excess water or liquid concrete escapes during pouring activities, it will be directed to lined and bermed areas adjacent to the borings, where the water will evaporate and the concrete will begin to set. Once the excess concrete has been allowed to set up, it will be removed and transported for disposal, according to applicable regulations.</p> <p><i>(Also see APM HM-4.)</i></p> |
| APM WQ-5 | <p>Soil Sampling/Wastewater and Groundwater Characterization. Soil sampling and potholing will be conducted in onshore project areas before construction begins, and soil information will be provided to construction crews to inform them about soil conditions and potential hazards. If hazardous substances are unexpectedly encountered during trenching, work will be stopped until the material is properly characterized and appropriate measures are taken to protect human health and the environment. If excavation of hazardous materials is required, they will be handled in accordance with applicable regulations.</p> <p>Prior to initiating excavation activities along the underground transmission cable routes, soil borings will be advanced to identify areas where contaminated groundwater may be contacted. The location, distribution, and/or frequency of the borings will give adequate representation of the conditions in the construction area. If suspected contaminated groundwater is encountered at the depths of the proposed construction, samples will be collected and submitted for laboratory analysis of petroleum hydrocarbons, metals, volatile organic compounds, and semi-volatile organic compounds. If necessary, groundwater will be collected during construction, contained, and disposed of in accordance with all applicable regulations. Appropriate personal protective equipment will be used and waste management will be performed in accordance with applicable regulations. Non-contaminated groundwater will be released to one of the city's combined sanitary and stormwater drainage systems (with prior approval) or contained, tested, and disposed of in accordance with applicable regulations.</p> <p><i>(Also see APM HM-5.)</i></p> |
| APM WQ-6 | <p>Horizontal Directional Drilling (HDD) Monitoring and Management. HDD operations will include best management practices for monitoring for loss of drilling fluids, spill containment and response measures. Monitoring and response measures specific to the site subsurface conditions and construction equipment will be included in a Frac-out Plan. The objectives of this monitoring program are to quickly identify any unplanned release of drilling fluids during drilling; determine the size, extent, and location of the release; and evaluate and implement appropriate containment and cleanup measures after a release has occurred. Routine monitoring will be conducted at regular intervals during all drilling activities. More intensive monitoring will be implemented if drilling fluid circulation to the HDD endpoints is lost or an unplanned release is detected.</p> <p>In general, both the drilling technique and early detection and response shall be used to minimize release of fluids to the environment. Techniques to minimize potential loss of drilling fluids include termination of the pilot hole short of the exit into the bay, monitoring of fluid pressures, and adjustments to the drilling fluid mix (see PEA Section 2.6.4, Submarine Cable Installation.) To minimize any potential impacts to water quality, drilling muds (which are heavier than water) shall consist of naturally occurring materials such as water and bentonite clay, plus inert, non-toxic polymers. Monitoring measures that will be included in the Frac-out Plan include use of dyes in the fluid, use of a fluorometer to determine dye concentrations in the water column, and monitoring by divers or side scan sonar in the event of loss of circulation of the fluid; potential responses to a release include measures such as reductions in drilling pressure, thickening of the fluid mixture, and in the event of an emergency, cessation or substantial reduction of drilling and fluid circulation. On land, measures would include installation of spill control berms and pits. For a release in the water column, divers and side scan sonar will be used to track the extent and location of the release. Appropriate containment and clean-up measures will be employed depending on the amount and location of the release, including disposal of material. Waste drilling fluids will be collected in a manner that is in accordance with all local, state and federal regulations.</p> <p><i>(Also see APM HM-6 and APM WQ-7.)</i></p> |
| APM WQ-7 | <p>Prevention of Contaminant Migration along HDD Route. The project will be designed to prevent contaminants along the HDD route from leaching to the shoreline or bay via the boreholes of the HDD. In areas of contamination (as determined by soil and sediment sampling) the HDD conduit can be sealed to effectively plug voids that might permit movement of contaminants down the HDD drill path after the HDD initial drill is established and the HDD conduit is being pulled into position. In the event that contaminants are found during pre-construction sampling, in areas where contaminants are found and where there are potential voids between the conduit and surrounding soil the voids will be filled with grout or similar material to prevent any potential preferential pathway for the passage of contaminants, as described below.</p> |

Table 4-5. Applicant Proposed Measures (APMs)

| | |
|------------------------------|---|
| APM WQ-8 | <p>Sediment Testing Program and Sediment Controls for Submarine Cable and Offshore HDD Intercept. Sediments along the submarine cable route are located near known contaminated sediment areas (SFEI, 2012), and may be contaminated with PAHs, metals, and/or pesticides. These compounds are generally insoluble or have low solubility in water. Sediments will be temporarily disturbed during hydroplow operations and during excavation of the HDD exit pits. In coordination with the DMMO, PG&E will prepare a Sampling and Analysis Plan for the sampling and analysis of sediment along the submarine cable route and where the HDD exits into the Bay. As part of preparation and implementation of the Sampling and Analysis Plan, surveys will be conducted to examine water depths, slopes, sediment types, potential contaminants, and any other activities or obstacles. Sensitive habitats, cultural resources, existing and abandoned pipelines, old cables, and material discarded on the bottom of the Bay will be located to ensure the new cable will be installed so as to avoid these conflicts or obstacles. In cases where a cable must cross a pipeline or existing cable, arrangements will be made with the owner of the existing installation to establish necessary separations between each installation (ICPC, 2009).</p> <p>The HDD offshore exits were selected far enough into the Bay to minimize the potential for encountering near-shore contaminated sediments. At an HDD exit location, it is a common practice to deploy divers to excavate a collection pit approximately 100 to 400 square feet and 6 feet deep at the exit point depending on final design. The results of the sediment sampling will be used to plan the appropriate handling of sediment resulting from the excavation of the HDD pit as determined in consultation with the DMMO. As the HDD is installed, drilling muds, which are heavier than water, will collect in this excavated collection pit. A barge on the surface is used during HDD installation to pump these drilling muds into a containment tank on the barge/ship for appropriate disposal. Hydroplow installation causes temporary disturbance of sediments. Most of the fluidized material falls back behind the hydroflow jets and increases in turbidity along the narrow path of the jets are minimized. Turbidity is limited by controlling the pressure of the jets and the rate of hydroplow advancement. The hydroplow is instrumented to enable measurement and control of pressure and tow tension.</p> <p><i>(Also see APM HM-7.)</i></p> |
| APM WQ-9 | <p>Project Site Restoration. As part of the final construction activities, PG&E will restore all removed curbs and gutters, repave, and restore landscaping or vegetation as necessary.</p> |
| APM WQ-10 | <p>Sediment Monitoring and Response Plan. Estimates of the amounts of material that may be suspended will vary depending on the specific type of equipment to be used. During final design, the expected equipment type will be identified and an evaluation can be made of the amount of sediment expected to be suspended. Along with the sediment quality information being gathered as described in APM WQ-8 and APM HM-7, this information will be used to determine, in coordination with the RWQCB, allowable thresholds of turbidity in the area of operations. A Sediment Monitoring and Response Plan will be developed in coordination with the RWQCB, taking into account equipment and the results of sediment sampling, that will set monitoring distance and methodology, acceptable thresholds of turbidity compared to background, and adaptive operational controls that will be used to reduce sediment suspension. These controls may include, but are not limited to, increasing or decreasing the speed of cable installation operation, increasing or decreasing the operational jet nozzle pressure, adjusting the operational angle of the jet nozzles on the burial blade, and other operational parameters that may reduce sediment suspension.</p> |
| Land Use and Planning | |
| APM LU-1 | <p>Provide Construction Notification and Minimize Construction Disturbance. A public liaison representative will provide the public with advance notification of construction activities, between two and four weeks prior to construction. The announcement shall state specifically where and when construction will occur in the area. Notices shall provide tips on reducing noise intrusion, for example, by closing windows facing the planned construction. PG&E shall also publish a notice of impending construction in local newspapers, stating when and where construction will occur.</p> <p>All construction activities will be coordinated with the City and Port of San Francisco at least 30 days before construction begins in these areas. Work will be coordinated to minimize any potential conflicts with other construction or recreational projects.</p> |
| APM LU-2 | <p>Provide Public Liaison Person and Toll-Free Information Hotline. PG&E shall identify and provide a public liaison person before and during construction to respond to concerns of neighboring residents about noise, dust, and other construction disturbance. Procedures for reaching the public liaison officer via telephone or in person shall be included in notices distributed to the public as described above. PG&E shall also establish a toll-free telephone number for receiving questions or complaints during construction.</p> |

Table 4-5. Applicant Proposed Measures (APMs)

| Mineral Resources | |
|---|---|
| Since economically viable sources of rock materials are not mapped along or adjacent to any portion of the project route, no mineral resource-related Applicant Proposed Measures are included with this project. | |
| Noise | |
| APM NO-1 | Noise Minimization with Portable Barriers. Compressors and other small stationary equipment used during construction will be shielded with portable barriers if located within 200 feet of a residence. |
| APM NO-2 | Noise Minimization with Quiet Equipment. Quiet equipment (for example, equipment that incorporates noise-control elements into the design; e.g., quiet model compressors can be specified) will be used during construction whenever possible. |
| APM NO-3 | Noise Minimization through Direction of Exhaust. Equipment exhaust stacks and vents will be directed away from buildings where feasible. |
| APM NO-4 | Noise Minimization through Truck Traffic Routing. Truck traffic will be routed away from noise-sensitive areas where feasible. |
| APM NO-5 | Noise Disruption Minimization through Residential Notification. In the event that nighttime construction is necessary because of clearance restrictions, affected residents will be notified in advance by mail, personal visit, or door-hanger and informed of the expected work schedule. |
| APM NO-6 | HDD Noise Minimization Measures. Temporary barriers utilizing materials such as intermodal containers or frac tanks, plywood walls, mass-loaded vinyl (vinyl impregnated with metal) or hay bales will be used to reduce noise generated by the onshore HDD operations. If night-time HDD activities are required, the project will monitor actual noise levels from HDD activities between 8:00 p.m. and 7:00 a.m. If the noise levels created by the HDD operation are found to be in excess of the ambient noise level by 5 dBA at the nearest property plane, PG&E will, within 24 hours of the excess measurement, employ additional minimization measures necessary to limit the increase to 5 dBA. Such measures may include ensuring semi-permanent stationary equipment (generators, lights, etc.) are stationed as far from sensitive areas as practicable, utilize "quiet" or "Hollywood/Movie Studio" silencing packages, and/or modify barriers to further reduce noise levels. |
| APM NO-7 | Noise Minimization Equipment Specification. PG&E will specify general construction noise reduction measures that require the contractor to ensure all equipment is in good working order, adequately muffled and maintained in accordance with the manufacturers' recommendations. |
| Population and Housing | |
| No Applicant Proposed Measures are included for population and housing. | |
| Public Services | |
| No Applicant Proposed Measures are included for public services. | |
| Recreation | |
| No Applicant Proposed Measures are included for recreation. | |

Table 4-5. Applicant Proposed Measures (APMs)

| Transportation | |
|-------------------------------|--|
| APM TR-1 | <p>Traffic Management Implementation. PG&E will follow its standard safety practices, including installing appropriate barriers between work zones and transportation facilities, posting adequate signs, and using proper construction techniques. PG&E will coordinate construction traffic access at Embarcadero Substation and Potrero Switchyard with SFMTA during project construction. PG&E is a member of the California Joint Utility Traffic Control Committee, which published the California Joint Utility Traffic Control Manual (2010). PG&E will follow the recommendations in this manual regarding basic standards for the safe movement of traffic on highways and streets in accordance with Section 21400 of the CVC. These recommendations include provisions for safe access of police, fire, and other rescue vehicles.</p> <p>In addition, PG&E will apply for an Excavation Permit and a Special Traffic Permit from the City of San Francisco, and will also submit a Traffic Management Plan to the City as part of his application. The Traffic Management Plan will include the following elements and activities:</p> <ul style="list-style-type: none"> ▪ Consult with SF Muni at least one month prior to construction to coordinate bus stop relocation (as necessary) and to reduce potential interruption of transit service, especially to the Transbay Temporary Terminal. ▪ Include a discussion of work hours, haul routes, limits on lengths of open trench, work area delineation, traffic control and flagging. ▪ Identify all access and parking restrictions and signage requirements, including any bicycle route or pedestrian detours, should the need for these arise during final design. ▪ Lay out a plan for notifications and a process for communicating with affected residents and businesses prior to the start of construction. Advance public notification would include postings of notices and appropriate signage of construction activities. The written notification shall include the construction schedule, the exact location and duration of activities within each street (i.e., which lanes and access points/driveways would be blocked on which days and for how long), and a toll-free telephone number for receiving questions or complaints. ▪ Include a plan to coordinate all construction activities with emergency service providers in the area at least one month in advance. Emergency service providers shall be notified of the timing, location, and duration of construction activities. All roads shall remain passable to emergency service vehicles at all times. ▪ Include the requirement that all open trenches be covered with metal plates at the end of each workday to accommodate traffic and access. ▪ Specify the street restoration requirements pursuant to PG&E’s franchise agreements with the City and County of San Francisco. ▪ Identify all roadway locations where special construction techniques (e.g., horizontal boring, directional drilling, or night construction) would be used to minimize impacts to traffic flow. ▪ Develop circulation and detour plans to minimize impacts to local street circulation. This may include the use of signing and flagging to guide vehicles through and/or around the construction zone. These plans will also address loading zones. |
| APM TR-2 | <p>Marine Traffic Management Implementation. PG&E and its contractors will coordinate with the USCG VTS to establish a Vessel Safety Zone, and will provide information for the appropriate notices to mariners for cable laying work. The USCG requires 90-day notification for establishment of the Vessel Safety Zone. This information is then disseminated by the USCG to mariners and other parties.</p> |
| Utilities and Service Systems | |
| APM UTIL-1 | <p>Coordination with SFPUC Regarding Stormwater System Facilities. One of the extremely large SFPUC stormwater transport/storage boxes underlies The Embarcadero, where the northern HDD is planned. In this area, the HDD depth will be coordinated with SFPUC, in order to prevent damaging the storage box.</p> |

4.14 Other Permits and Approvals

The CPUC is the lead agency for CEQA review of this project. In accordance with CPUC General Order 131-D, PG&E prepared and submitted a Proponent’s Environmental Assessment (PEA) as part of its CPCN application (A.12-12-004). The CPUC has exclusive authority to approve or deny PG&E’s application; however, various permits from other agencies may also need to be obtained by PG&E to build the Proposed Project. If the CPUC issues a CPCN, it would provide overall project approval and certify compliance of the project with CEQA. In addition to the CPCN, Table 4-6 summarizes the other permits or approvals from other federal, State, and local agencies that may be needed for the project.

Table 4-6. Permits that May Be Required for the Embarcadero-Potrero 230 kV Transmission Project

| Agency | Jurisdiction | Requirements |
|---|--|---|
| Federal/State Agencies | | |
| U.S. Army Corps of Engineers (USACE), San Francisco District | San Francisco Bay | Permit (i.e., a federal action) and Environmental Assessment for marine cable installation in San Francisco Bay under the Clean Water Act Section 404 and the Rivers and Harbors Act Section 10. |
| USACE, Operations and Readiness Division, Dredged Material Management Office (DMMO) | San Francisco Bay | Consolidated Dredging-Dredge Material Reuse/Disposal authorization, if needed for HDD exit pits |
| U.S. Coast Guard (USCG) | San Francisco Bay | Establish Vessel Traffic Safety zone; Issuance of appropriate Notice to Mariners |
| San Francisco Bay Conservation and Development Commission (BCDC) | San Francisco Bay | Permit for dredging and disposal activity in the bay, if needed for HDD exit pits; Administrative permit for work within the Bay and/or shoreline band; Determination of consistency of USACE federal action with San Francisco Bay Plan under the federal Coastal Zone Management Act (CZMA) |
| National Marine Fisheries Service (NMFS), Southwest Regional Office | San Francisco Bay | Consultation or technical assistance under Section 7 of the Endangered Species Act (ESA) regarding USACE permit; Potential impact to Essential Fish Habitat (EFH); Potential Incidental Harassment Authorization (IHA) permit under Marine Mammal Protection Act (MMPA) |
| U.S. Fish and Wildlife Service (USFWS), Sacramento Field Office | San Francisco Bay | Consultation under Section 7 of the Endangered Species Act (ESA) regarding USACE permit; Enforcement of the Migratory Bird Treaty Act (MBTA) |
| California Department of Fish and Wildlife (CDFW) | Endangered species consultation | California Endangered Species Act coordination, Section 20801 Incidental Take Permit or Consistency Determination under California Fish and Game Code Section 2080.1, Native Plant Protection Act , and other provisions of the Fish and Game Code as applicable |
| Regional Water Quality Control Board (RWQCB) – San Francisco Bay Region | San Francisco Bay Hydrologic Region | National Pollution Discharge Elimination System (NPDES); General Construction Storm Water Pollution Prevention Plan (SWPPP); Water Quality Certification |
| California State Lands Commission (CSLC) | Tidal waterways of the bay and submerged lands below the mean high tide line | Residual and review authority over actions managing lands legislatively granted to City and County of San Francisco. |
| California Department of Transportation (Caltrans) | Spear Street area under the Bay Bridge | Encroachment permit and design review |

Table 4-6. Permits that May Be Required for the Embarcadero-Potrero 230 kV Transmission Project

| Agency | Jurisdiction | Requirements |
|---|---|--|
| Local/Regional Agencies | | |
| Port of San Francisco | San Francisco Bay and waterfront lands, including portions of Spear Street and the proposed Potrero 230 kV Switchyard | License |
| City and County of San Francisco | 23rd Street, Shoreline to Potrero Switchyard; Spear Street and Folsom Street | ROW Acquisition and/or reestablish utility franchise area |
| San Francisco Municipal Transportation Agency (SFMTA) | City streets and sidewalks | Special Traffic Permit, with Traffic Management Plan |
| San Francisco Department of Public Works (SFDPW) | City streets and sidewalks | Excavation Permit |
| San Francisco Department of Public Works or Department of Building Inspection | City streets and sidewalks | Special permit for nighttime construction work under the Noise Ordinance (Section 2908 of Police Code) |
| San Francisco Public Utilities Commission (SFPUC) | Dewatering and Water Supply | Water disposal and water supply for construction activity |

4.15 Electric and Magnetic Fields Summary

4.15.1 Electric and Magnetic Fields

Recognizing that there is public interest and concern regarding potential health effects that could result from exposure to electric and magnetic fields (EMF) from power lines, this document provides information regarding EMF associated with electric utility facilities and the potential effects of the Proposed Project related to public health and safety. Potential health effects from exposure to **electric fields** from power lines (produced by the existence of an electric charge, such as an electron, ion, or proton, in the volume of space or medium that surrounds it) are typically not of concern since electric fields are effectively shielded by materials such as trees, walls, etc. Therefore, the majority of the following information related to EMF focuses primarily on exposure to **magnetic fields** (invisible fields created by moving charges) from power lines.

Magnetic fields can be reduced either by cancellation or by increasing distance from the source. Cancellation is achieved in two ways. A transmission line circuit consists of three “phases”: three separate wires (conductors), usually on an overhead tower. The configuration of these three conductors can reduce magnetic fields. When the configuration places the three conductors closer together, the interference, or cancellation, of the fields from each wire is enhanced, and the magnetic field is reduced. This technique has practical limitations because of the potential for short circuits if the wires are placed too close together. Close conductor spacing can also create worker safety concerns because there is a risk of workers contacting energized conductors during maintenance. The cables used in underground high voltage transmission lines are insulated (coated) to allow the three phases to be much closer together than on overhead lines.

This Initial Study does not consider magnetic fields in the context of CEQA and determination of environmental impact. This is because (a) there is no agreement among scientists that EMF does create a potential health risk, and therefore, (b) there are no defined or adopted CEQA standards for defining health risk from EMF. As a result, EMF information is presented for the benefit of the public and decisionmakers.

After several decades of study regarding potential public health risks from exposure to power line EMF, research results remains inconclusive. Several national and international panels have conducted reviews of data from multiple studies and state that there is not sufficient evidence to conclude that EMF causes cancer. The International Agency for Research on Cancer (IARC), an agency of the World Health Organization (WHO), and the California Department of Health Services (DHS) both classified EMF as a possible carcinogen (WHO, 2001; DHS, 2002).

In addition, the 2007 WHO [Environmental Health Criteria (EHC) 238] report concluded that:

- Evidence for a link between Extremely Low Frequency (ELF, 50–60 Hz) magnetic fields and health risks is based on epidemiological studies demonstrating a consistent pattern of increased risk for childhood leukemia. However, “...virtually all of the laboratory evidence and the mechanistic evidence fail to support a relationship between low-level ELF magnetic fields and changes in biological function or disease status....the evidence is not strong enough to be considered causal but sufficiently strong to remain a concern.”
- “For other diseases, there is inadequate or no evidence of health effects at low exposure levels.”

Currently, there are no applicable regulations related to EMF levels from power lines or substations. However, following a CPUC decision from 1993 (Decision [D.]93-11-013) that was reaffirmed by the CPUC on January 27, 2006 (D.06-01-042), the CPUC requires utilities to incorporate “low-cost” or “no-cost” measures to mitigate EMF from new or upgraded electrical utility facilities up to approximately 4 percent of total project cost. To comply with this requirement, PG&E developed and included a Preliminary Transmission EMF Management Plan as part of the proposed Embarcadero-Potrero 230 kV Transmission Project to reduce magnetic field levels in the vicinity of the transmission line.

4.15.2 EMF in the Proposed Project Area

Residents and owners of a day care facility near the proposed Embarcadero-Potrero 230 kV Transmission Project have expressed concerns about the specific location in the city streets where the underground 230 kV line would be located and the proposed depth of burial. These concerns focus on the safety and health effects to people in the residential apartments and condominium towers (along Spear and Folsom Streets) and Bright Horizons/Marin Day School Hills Plaza Campus day care that would be adjacent to the northern portion of the transmission line. This section discusses PG&E’s general practices regarding EMF and the specific EMF reduction measures proposed by PG&E for the Proposed Project.

Magnetic field strength is a function of both the electric current carried by the wires, and the configuration and design of the three conductors that together form a single circuit of an electric transmission line. Magnetic field strengths for typical transmission power line loads at the edge of an overhead transmission system right-of-way generally range from 10 to 30 milliGauss (mG) (NIEHS, 2002). Exposure to EMF occurs in the community from sources other than electric transmission lines. Research on ambient magnetic fields in homes indicates that levels below 0.6 mG could be found in half of the studied homes in the centers of rooms, and that the average levels in the homes away from electrical appliances was 0.9 mG. Immediately adjacent to appliances (within 12 inches), field values are much higher, for example: 4 to 8 mG near electric ovens and ranges, 20 mG for portable heaters, or 60 mG for vacuum cleaners (NIEHS, 2002).

Outside of the home, the public also experiences EMF exposure from the electric distribution system that is located throughout all areas of the community. In areas of underground electric distribution, such as downtown San Francisco, the distribution lines are not buried as deeply as the higher voltage transmission lines, and are not arranged to optimize field cancellation. Figure 4-19 shows the magnetic field levels experienced by a pedestrian traveling through downtown San Francisco, including the Folsom and Spear Street segments of the project’s underground route (PG&E, 2013a). The time-average levels of magnetic field exposure experienced by the pedestrian over the 40-minute period were 1.3 to 5.4 mG.

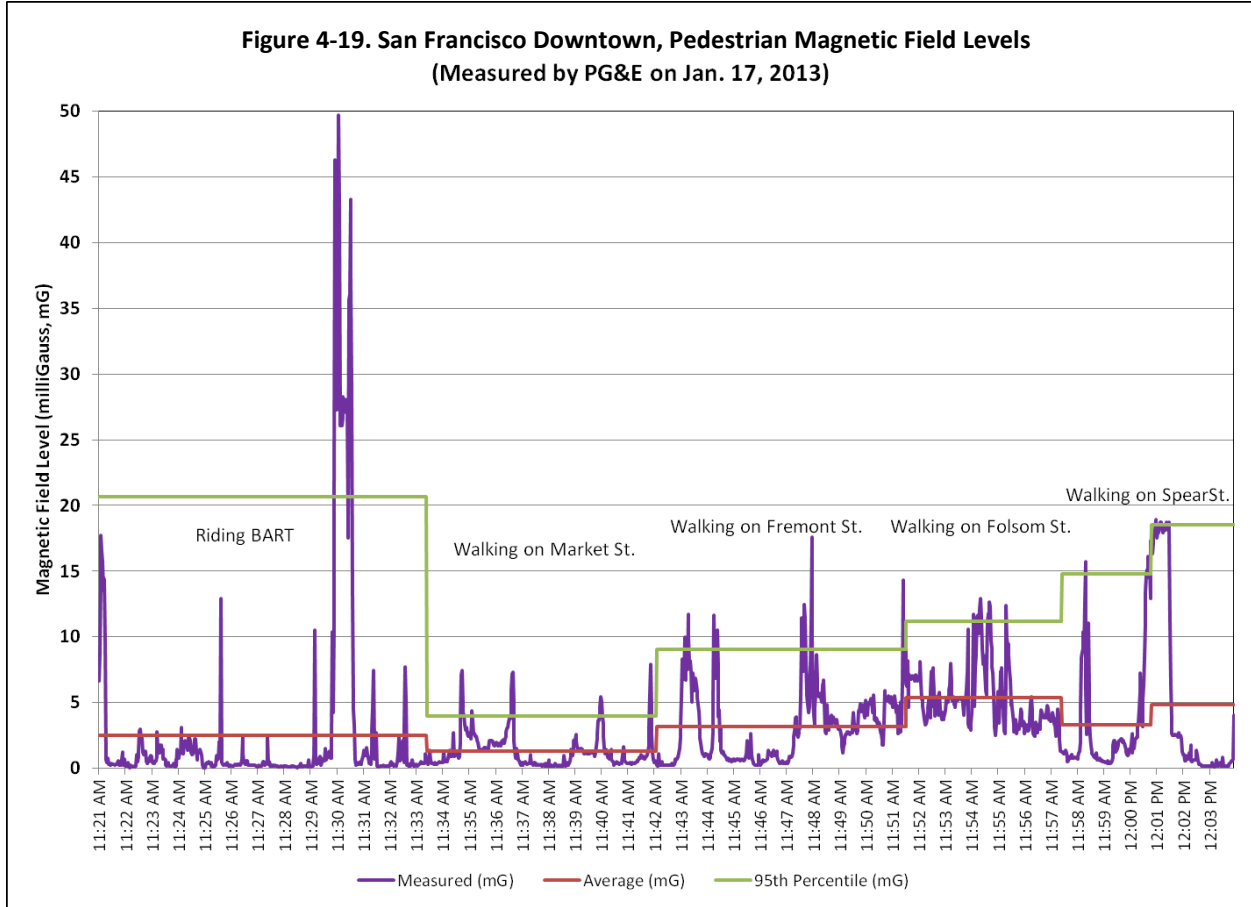

4.15.3 EMF Management Plan for the Proposed Project

PG&E’s EMF Design Guidelines. Without considering any of PG&E’s proposed measures to reduce magnetic fields, the base-case design of the Embarcadero-Potrero 230 kV Transmission Project would produce a magnetic field level of 29.4 mG measured at three feet above the ground along the centerline of the underground transmission line and 3.0 mG at 23 feet away from the centerline (PG&E, 2013a).

In accordance with Section X(A) of CPUC General Order 131-D, Decision No. D.06-01-042, and PG&E’s EMF Design Guidelines prepared in accordance with the EMF Decision, PG&E will incorporate “no cost” and “low cost” magnetic field reduction steps in the design of the proposed transmission line and switchyard.

PG&E’s guidelines call for implementation of measures to reduce magnetic fields based on the land uses surrounding each project, in the following priority:

- Schools or day care centers
- Residential properties
- Commercial/industrial land uses
- Recreational sites
- Agricultural lands
- Undeveloped land

The options in PG&E's EMF Design Guidelines include the following measures, any or all of which may be selected to reduce the magnetic field strength levels from the proposed transmission line:

- Arranging the conductors in a triangular configuration to maximize field cancellation.
- Placing the conductors for the transmission line in the right-of-way at the greatest distance from buildings housing priority land uses to reduce magnetic field exposure along the entire route, except where the location of existing underground utilities prevent strategic line placement.
- Moving the conductors further from the edge of the right-of-way near high priority groups including school, day care, and residential land uses. This can be done by installing the conductors in a deeper than normal trench, e.g., by lowering the depth of the duct bank five feet deeper than otherwise required by basic engineering practice.

Proposed EMF Reduction Measures. The Preliminary Transmission EMF Management Plan for the proposed Embarcadero-Potrero 230 kV Transmission Project includes each of these measures along the entire northern segment, including Spear and Folsom Streets to the Embarcadero Substation, as "no cost" and "low cost" magnetic field reduction steps:

- Triangular configuration,
- Strategic line placement, and
- Lowering the trench an additional five feet.

Placing the transmission line in a trench five feet lower than the base-case design would reduce the magnetic field level from the base-case of 29.4 mG to 10.9 mG, for a 63 percent reduction, when measured at three feet above the ground along the centerline of the underground transmission line. For locations 23 feet away from the centerline, the lower trench would reduce the magnetic field level from the base-case of 3.0 mG to 2.6 mG, for a 15 percent reduction (PG&E, 2013a).

Inspection of other underground utilities in the area is ongoing by PG&E. Final engineering and selection of the alignment of the line would include seeking opportunities to strategically place the line farther from priority land uses, where feasible.

Additional information regarding EMF and the Embarcadero-Potrero 230 kV Transmission Project can be found in Appendix C of the Proponent's Environmental Assessment, Electric and Magnetic Fields Discussion, and in CPCN application Exhibit D, Preliminary Transmission EMF Management Plan and Substation Checklist, which was submitted to the CPUC with PG&E's CPCN application (A.12-12-004). PG&E's CPCN application and Proponent's Environmental Assessment are available for public review at the CPUC Energy Division CEQA Unit and on the project website at:

<http://www.cpuc.ca.gov/Environment/info/aspen/embarc-potrero/embarc-potrero.htm>

If the project is approved by the CPUC, PG&E would prepare and submit to the CPUC a Final EMF Management Plan containing the precise EMF measures to be employed for the project. Interested parties may contact PG&E's Project Information Line at 415-973-5530 to receive a copy of the Final EMF Management Plan once it has been prepared (PG&E, 2012a).