

Technology Innovations to Reduce Wildfire Risk



David Erne, Energy Technology Systems Integration
California Energy Commission
March 21, 2019



Panel



James Keener



Alan Wong

IND.T



Tom Bialek



David Myers





MM3 for Feeders



ZM1 for Laterals

- *Conductor Sway Detection*
- *Pre-Ignition Detection*
- *Feeder Watchlist*
- *Worst Performing Feeder Alerts*



James Keener, CEO





Smart sensors along a typical 5km distance apart with 100+ assets, 24/365 early detection and location of fire risk faults



Alan Wong, CEO

IND.T

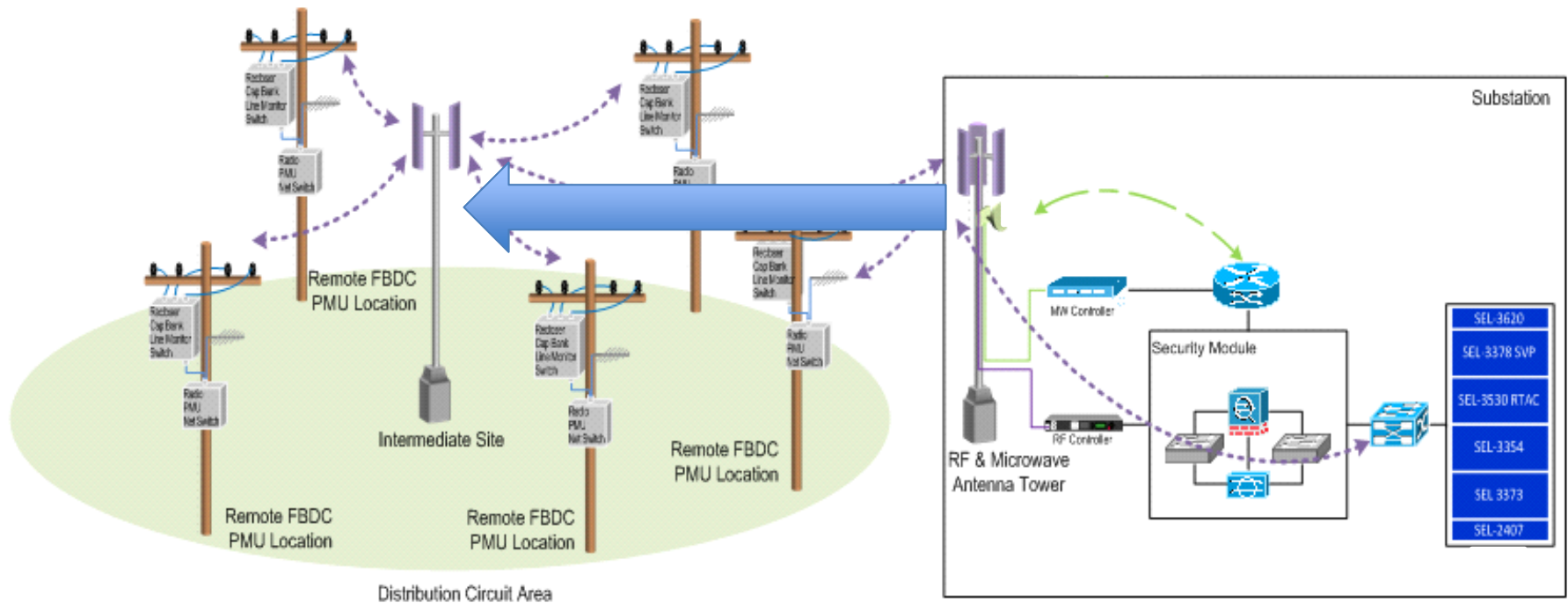

Ongoing Development

- Working with IT on a cellular based communication system for reduced implementation cost and improved availability.
- Expanding scope to include single phase branches in protection algorithm.
- Circuit midpoint implementation



Dr. Tom Bialek, Chief Engineer



A  Sempra Energy utility

IntelliRupter® PulseCloser® Fault Interrupter

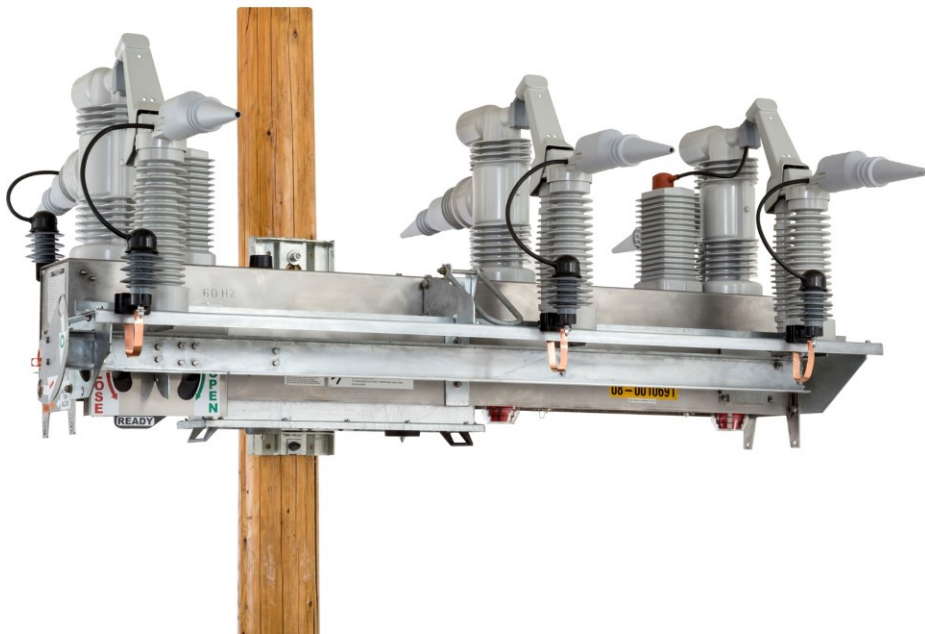

David Myers, VP Feeder Automation

Conventional Reclosing

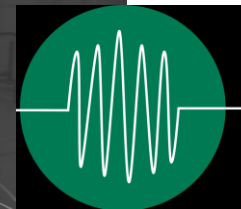
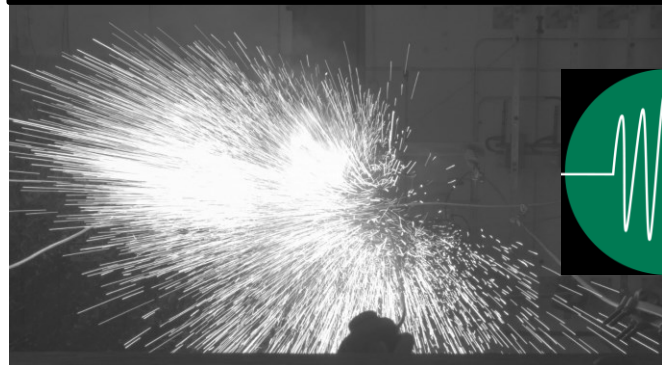

PulseClosing® Technology





Questions



Tom Bialek



James Keener



David Myers



Alan Wong

