



Clay Faber - Director
Regulatory Affairs
8330 Century Park Court
San Diego, CA 92123-1548

Tel: 858-654-3563
Fax: 858-654-1788
CFaber@semprautilities.com

June 4, 2013

**ADVICE LETTER 2487-E
(U 902-E)**

PUBLIC UTILITIES COMMISSION OF THE STATE OF CALIFORNIA

**SUBJECT: REQUEST FOR APPROVAL OF AMENDED RENEWABLE POWER
PURCHASE AGREEMENT WITH CSOLAR IV WEST LLC**

I. Introduction

A. Identify the purpose of the advice letter

San Diego Gas & Electric Company ("SDG&E") hereby seeks approval from the California Public Utilities Commission ("CPUC" or "Commission") to enter into a proposed amendment (the "Proposed Agreement") to an existing power purchase agreement (the "PPA") with CSolar IV West, LLC. ("Tenaska West"). The Proposed Agreement modifies the Original PPA by (1) extending the Commercial Online Date ("COD") from December 31, 2015 to December 31, 2016, (2) establishing a standard for calculating the number of megawatts of capacity expressed in direct current ("MWdc") where that term is used in the PPA, (3) allowing Tenaska West to install from 27 MWdc up to 41MWdc of non-concentrating solar photovoltaic ("PV") panels in the project in order to qualify it for cash grant to solar energy property in lieu of tax credits under Section 1603 of the American Recovery and Reinvestment Act of 2009, (4) to provide that the pricing for any the electricity produced by any non-concentrating solar PV panels will be at the price already provided for in the PPA for non-concentrating solar PV, (5) to modify the condition precedent regarding the deadline for Tenaska West to execute an engineering, procurement and construction ("EPC") contract for the project, (6) extend the deadline for Tenaska West to obtain financing, (7) extending the deadline for Tenaska West to notify SDG&E that it will construct the project utilizing non-concentrating PV panels exclusively, (8) allowing for additional non-concentrating solar PV panels to be installed, if needed to ensure the project meets its guaranteed commercial operation date, (9) conforming the calculations for guaranteed energy production to take into account the megawatt hours ("MWhs") to be produced from non-concentrating solar PV and (10) adding or modifying definitions, modifying dates, and making other conforming changes to project milestones and operational/technical sections of the PPA to make it consistent with the amendment. The full amendment is provided as Confidential Appendix F to Part 2 of this Advice Letter.

The purpose of the Amendment is to enhance project viability by giving the developer more time and flexibility in securing financing for the project. The Tenaska West project supports economic growth not only in the Imperial Valley, but also in San Diego because Tenaska intends to procure the concentrating solar panels from a local San Diego factory, thus supporting about 400 high-tech jobs in the local area.

By this Advice Letter filing, SDG&E requests that the Commission find that the terms and conditions of the PPA, as amended by the Proposed Agreement, are reasonable, that procurement under the PPA, as amended by the Proposed Agreement, is eligible to count

toward SDG&E's compliance with the Renewables Portfolio Standard ("RPS"), and that all payments from SDG&E under the PPA, as amended by the Proposed Agreement, may be recovered in SDG&E's rates.

B. Identify the subject of the advice letter, including:

1. Project name: CSolar IV West, LLC
2. Technology (including level of maturity): Concentrating solar PV with dual-axis tracking combined with non-concentrating solar PV. Solar PV is a mature technology with over 20,150 MWs of capacity installed worldwide, with over 1,564 MW installed in California. The Tenaska West project will be the first utility-scale project to utilize concentrating solar PV with dual-axis tracking.
3. General Location and Interconnection Point: Interstate 8 and Dunaway Road in El Centro, California. Interconnection to SDG&E's Imperial Valley Substation.
4. Owner(s) / Developer(s)
 - a. Name(s): Tenaska Solar Ventures, Inc.
 - b. Type of entity(ies) (e.g. LLC, partnership): Corporation
 - c. Business Relationship (if applicable, between seller/owner/developer): CSolar IV West is a wholly-owned subsidiary of Tenaska Solar Ventures, LLC, which is in turned owned by Tenaska Energy, Inc. and Tenaska Energy Holdings, LLC, which act as co-holding companies and are privately held companies. The companies are headquartered in Omaha, Nebraska.
5. Project background, e.g., expiring QF contract, phased project, previous power purchase agreement, contract amendment

The Proposed Agreement amends an existing, Commission-approved PPA that has not yet begun deliveries.

6. Source of agreement, i.e., RPS solicitation year or bilateral negotiation

The Proposed Agreement is the result of bilateral negotiations between Tenaska West and SDG&E.

C. General Project(s) Description

Project Name	CSolar IV West
Technology	Concentrating solar PV with dual axis tracking, and non-concentrating solar PV
Capacity (MW)	96-150 MW
Capacity Factor	29% for concentrating solar PV with dual-axis tracking, and 27% for non-

	concentrating solar PV
Expected Generation (GWh/Year)	381 GWh/Yr (at 150 MW)
Initial Commercial Operational Date (COD)	Expected December 31, 2016
Date contract Delivery Term begins	Upon reaching COD
Delivery Term (Years)	25 years
Vintage (New / Existing / Repower)	New
Location (city and state)	El Centro, California
Control Area (e.g., CAISO, BPA)	CAISO
Nearest Competitive Renewable Energy Zone (CREZ) as identified by the Renewable Energy Transmission Initiative (RETI) ¹	Imperial South (CREZ 30)
Type of cooling, if applicable	N/ A

D. Project location

1. Provide a general map of the generation facility's location

<http://maps.google.com/maps?q=interstate+8+and+dunaway+road,+el+centro,+california&hl=en&ll=32.7688,-115.802078&spn=0.446308,0.889206&sll=32.824552,-117.108978&sspn=0.892053,1.778412&hnear=Dunaway+Rd+%26+Interstate+8,+El+Centro,+California+92243&t=m&z=11>

2. For new projects describe facility's current land use type (private, agricultural, county, state lands (agency), federal lands (agency), etc.)

The project is located on fallow agricultural land controlled by Tenaska West.

E. General Deal Structure

Describe general characteristics of contract, for example:

1. Required or expected Portfolio Content Category of the proposed contract

Because the project is located within the State of California and has its first point of interconnection with CAISO, a California balancing authority, SDG&E expects the project output to count as Category 1 bundled energy and RECs under Portfolio Content Categories set forth in the Commission's Decision Number ("D.") 11-02-052.

2. Partial/full generation output of facility

SDG&E will purchase the full generation output of the facility, along the associated Green Attributes.

¹ Information about RETI is available at: <http://www.energy.ca.gov/reti/>

3. Any additional products, e.g. capacity

The project will also provide capacity to SDG&E for use in its Resource Adequacy compliance.

4. Generation delivery point (e.g. busbar, hub, etc.)

Power will be delivered at the point of interconnection with the CAISO at the Imperial Valley Substation.

5. Energy management (e.g. firm/shape, scheduling, selling, etc.)

The energy will be delivered to CAISO without any firming or shaping. SDG&E will be the scheduling coordinator for the facility.

6. Diagram and explanation of delivery structure

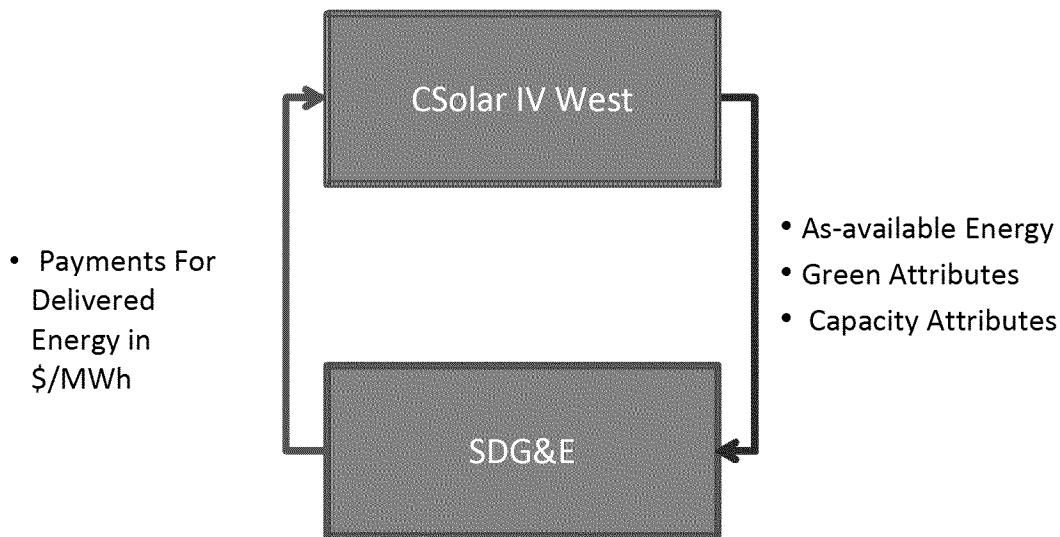
F. RPS Statutory Goals & Requirements

1. Briefly describe the Project's consistency with and contribution towards the RPS program's statutory goals set forth in Public Utilities Code §399.11. These goals include displacing fossil fuel consumption within the state; adding new electrical generating facilities within WECC; reducing air pollution in the state; meeting the state's climate change goals by reducing emissions of greenhouse gases associated with electrical generation; promoting stable retail rates for electric service; a diversified and balanced energy generation portfolio; meeting the state's resource adequacy requirements; safe and reliable operation of the electrical grid; and implementing state's transmission and land use planning activities.

The PPA, as amended, will displace up to 150 MW of fossil fuel generation in each operating hour, and comply with State policies regarding greenhouse gases because it does not produce any greenhouse gas or other emissions. The PPA's fixed rates for each contract year promote stability for electricity prices and rates. By utilizing solar generation technology, the project will contribute to the diversity of SDG&E's electric generation portfolio and help SDG&E achieve and maintain the required 33% RPS target. The project will also provide capacity to SDG&E to count toward SDG&E's resource adequacy

requirements. The PPA will deliver its energy to SDG&E utilizing the capacity on the Sunrise Powerlink, making effective use of existing transmission infrastructure, and any required reliability or deliverability upgrades will be built to ensure safe and reliable transmission operations and full deliverability of the project. The project was received its Conditional Use Permit from Imperial County on October 11, 2011 and approval for its transmission right-of-way from the Bureau of Land Management on September 27, 2011, thus demonstrating its compatibility with local land use priorities.

Nothing in the Proposed Agreement alters any of the above characteristics of the Original PPA.

2. Describe how procurement pursuant to the contract will meet IOU's specific RPS compliance period needs.

By extending the COD of the project from the end of 2015 to the end of 2016, the Proposed Agreement defers any output from the project until Compliance Period 3 ("CP3"), which begins in 2017. This defers an entire year's worth of output from the project from Compliance Period 2 ("CP2") to CP3 and helps SDG&E optimize the portfolio by eliminating from CP2 energy that potentially will not be needed. This brings value to ratepayers because they are not paying for energy that is potentially not needed for compliance. Even if SDG&E faces a shortfall in meeting its CP2 RPS compliance obligation as a result of this deferment, SDG&E could probably procure unbundled RECs at a cheaper price to make up any shortfall.

G. Confidentiality

Explain if confidential treatment of specific material is requested. Describe the information and reason(s) for confidential treatment consistent with the showing required by D.06-06-066, as modified by D.08-04-023.

SDG&E requests that Part 2 of this Advice Letter filing, Confidential Appendices A through G, which contain confidential information such as contract terms, contract analysis, SDG&E's net short position, and other information specifically protected by D.06-06-066, as modified by subsequent decisions, be kept confidential by the Commission. The confidential material is not found in Part 1, the public version of the filing. This request for confidential treatment is supported by the accompanying Declaration of Theodore Roberts.

II. Consistency with Commission Decisions

A. RPS Procurement Plan

1. Identify the Commission decision that approved the utility's RPS Procurement Plan. Did the utility adhere to Commission guidelines for filing and revisions?

SDG&E filed its 2012 RPS Procurement Plan (the “2012 Plan”) on November 29, 2012.² The Commission had approved SDG&E’s 2012 Plan in D.12-11-016 and directed SDG&E to modify the plan. The conformed plan was filed on November 29, 2012 and amended on December 13, 2012.

SDG&E’s approved 2012 Plan provides that SDG&E will seek to procure resources to:

- Assure that it has enough RPS energy to meet the RPS program requirements;
 - Look for opportunities to maximize ratepayer value through banking, sales and short term purchases; and
 - Diversity its RPS portfolio in order to mitigate risks.
2. Describe the Procurement Plan’s assessment of portfolio needs.

SDG&E’s portfolio need is calculated based on a probability-weighted projection of generation from projects in the existing portfolio compared to the forecasted demand and the required RPS percentage.

3. Discuss how the Project is consistent with the utility’s Procurement Plan and meets utility procurement and portfolio needs (e.g. capacity, electrical energy, resource adequacy, or any other product resulting from the project).

As stated above, the Proposed Agreement follows SDG&E’s RPS Procurement Plan by helping optimize SDG&E’s portfolio and reducing ratepayer costs.

4. Describe the project characteristics set forth in the solicitation, including the required deliverability characteristics, online dates, locational preferences, etc. and how the Project meets those requirements.

The 2012 RFO was seeking projects with online dates beginning no earlier than December of 2016. The Proposed Agreement meets that criterion by extending the online date for the project from December 31, 2015 to December 31, 2016. Aside from the online date, the RFO did not specify locational or other preferences, and resource adequacy was not required. For projects with transmission upgrade costs above a pre-determined level, there was the possibility of a price reduction. The Proposed Agreement was executed in 2011 and has already passed the screens for the transmission upgrades.

5. For Sales contracts, provide an analysis that evaluates selling the proposed contracted amount vs. banking the RECs towards future RPS compliance requirements (or any reasonable other options).

² Discussions that led to the negotiation and execution of the Proposed Agreement began earlier in 2012, when SDG&E was procuring under its 2011 RPS Procurement Plan.

NA - not a sales contract.

B. Bilateral contracting – if applicable

1. Discuss compliance with D.06-10-019 and D.09-06-050.

In D.06-10-019, the Commission concluded that bilateral contracts used for RPS compliance must be submitted for approval via advice letter and, while not subject to the MPR, must contain pricing that is “reasonable.”³ In D.09-06-050, the Commission established price benchmarks and contract review processes for very short term (< four years), moderately short term (at least 4 years, less than 10 yrs.) and bilateral RPS contracts. The Proposed Agreement conforms to the price benchmarking requirements of D.06-10-019 and D.09-06-050. The pricing ranks in the mid-range of contracts recently executed by SDG&E, and toward the upper end of bids submitted into SDG&E’s 2012 RPS RFO. The comparison with other agreements is discussed in more detail in Part 2, Confidential Appendix A.

2. Specify the procurement and/or portfolio needs necessitating the utility to procure bilaterally as opposed to a solicitation.

Because the Proposed Agreement is an amendment to an existing PPA that touches on many interrelated aspects of that PPA, it was not feasible for the amended agreement to be submitted into an RFO. Therefore, the parties negotiated the amendment bilaterally.

3. Describe why the Project did not participate in the solicitation and why the benefits of the Project cannot be procured through a subsequent solicitation.

N/A – amendment to an existing, approved contract.

C. Least-Cost, Best-Fit (LCBF) Methodology and Evaluation

1. Briefly describe IOU’s LCBF Methodology

SDG&E’s LCBF methodology evaluates each offer on the basis of energy value, capacity value, price, congestion costs, transmission upgrade costs, deliverability, and integration costs. The specific analysis of the Proposed Agreement is found in Part 2, Confidential Appendix A.

2. Indicate when the IOU’s Shortlist Report was approved by Energy Division

SDG&E submitted the final 2011 RFO Shortlist to Energy Division on August 31, 2012. The shortlist for the 2012 RFO will be submitted to the Commission on June 7, 2013.

D. Compliance with Standard Terms and Conditions (STCs)

1. Does the proposed contract comply with D.08-04-009, D.08-08-028, and D.10-03-021, as modified by D.11-01-025?

³ D.06-10-019, *mimeo*, p. 31.

The Non-Modifiable STCs are contained within the Original PPA and the Proposed Agreement, with the exception of the “REC-only” STCs. Those are not included because neither the Original PPA nor the Proposed Agreement are REC purchases.

2. Using the tabular format, provide the specific page and section number where the RPS non-modifiable STCs are located in the contract.

Non-Modifiable Term	Contract Section Number	Contract Page Number
STC 1: CPUC Approval	1.1 of <i>Original PPA</i>	6 of <i>Original PPA</i>
STC 2: Green Attributes and RECs	1.1 of <i>Original PPA</i> 3.1 (i) of <i>Original PPA</i>	12 of <i>Original PPA</i> 28 of <i>Original PPA</i>
STC 6: Eligibility	10.2 of <i>Original PPA</i>	52 of <i>Original PPA</i>
STC 17: Applicable Law	13.8 of <i>Original PPA</i>	60 of <i>Original PPA</i>
STC REC 1: Transfer of RECs	N/A – not a REC contract	
STC REC 2: WREGIS Tracking of RECs	N/A – not a REC contract	
STC REC 3: CPUC Approval	N/A – not a REC contract	

3. Provide a redline of the contract against the utility’s Commission-approved pro forma RPS contract as Confidential Appendix E to the filed advice letter. Highlight modifiable terms in one color and non-modifiable terms in another.

See Part 2, Confidential Appendix E

E. Portfolio Content Category Claim and Upfront Showing (D.11-12-052, Ordering Paragraph 9)

1. Describe the contract’s claimed portfolio content category

The Proposed Agreement will be claimed under Cal. Pub. Util. Code Section 399.16(b)(a)(A). That category is described as follows:

Hav[ing] a first point of interconnection with a California balancing authority, have a first point of interconnection with distribution facilities used to serve end users within a California balancing authority area, or are scheduled from the eligible renewable energy resource into a California balancing authority without substituting electricity from another source. The use of another source to provide real-time ancillary services required to maintain an hourly or sub-hourly import schedule into a California balancing authority shall be permitted, but only the fraction of

the schedule actually generated by the eligible renewable energy resource shall count toward this portfolio content category

2. Explain how the procurement pursuant to the contract is consistent with the criteria of the claimed portfolio content category as adopted in D.11-12-052

The project will have its first point of interconnection with CAISO, a California balancing authority.

3. Describe the risks that the procurement will not be classified in the claimed portfolio content category

The only perceived risk to the project not being classified as claimed would be an intervening change of law prior to the project reaching COD.

4. Describe the value of the contract to ratepayers if:

- a. Contract is classified as claimed

If the contract continues to be grandfathered, ratepayers will benefit from the savings in RPS compliance costs made possible by the extension of the COD to CP3.

- b. Contract is not classified as claimed

If the contract classification were changed to Category 2, then ratepayers might be faced with higher costs for RPS energy if SDG&E had to procure additional volumes of Category 1 energy and RECs to comply with Pub. Util. Code Section 399.16(c)(1) or (2).

That ratepayer risk would be compounded if the Proposed Agreement were classified as a Category 3, since starting in 2017 SDG&E will be limited to only ten percent (10%) of its total RPS portfolio qualifying for compliance in that category. Ratepayers would either be paying for RPS energy and RECs that could not be used for compliance and would have to be resold (presumably, at a much lower cost) or be banked for future use, which may or may not be possible.

F. Minimum Quantity

Minimum contracting requirements apply to short term contracts less than 10 years in length

1. Explain whether or not the proposed contract triggers the minimum quantity requirement

N/A- the Proposed Agreement is for a term of 25 years.

2. If the minimum quantity requirement applies, provide a detailed calculation that shows the extent to which the utility has satisfied the minimum quantity requirement. If the requirement has not yet been satisfied for the current year, explain how the utility expects to satisfy the quantity by the end of the year to count the proposed contract for compliance.

N/A

G. Tier 2 Short-term Contract “Fast Track” Process

1. Is the facility in commercial operation? If not in commercial operation, explain the IOU’s basis for their determination that commercial operation will be achieved within the required six months.

N/A- contract was negotiated bilaterally and is ineligible for Fast Track.

2. Describe and explain any contract modifications to the Commission-approved short-term pro forma contract.

N/A- contract was negotiated bilaterally and is ineligible for Fast Track.

H. Interim Emissions Performance Standard

In D.07-01-039, the Commission adopted a greenhouse gas Emissions Performance Standard (EPS) which is applicable to an electricity contract for baseload generation, as defined, having a delivery term of five years or more.

1. Explain whether or not the contract is subject to the EPS.

The Proposed Agreement is for as-available energy with a capacity factor below 60%. It is therefore not subject to the EPS..

2. If the contract is subject to the EPS, discuss how the contract is in compliance with D.07-01-039.

N/A

3. If the contract is not subject to EPS, but delivery will be firmed/shaped with specified baseload generation for a term of five or more years, explain how the energy used to firm/shape meets EPS requirements.

N/A – no firming and shaping is involved.

4. If the contract term is five or more years and will be firmed/shaped with unspecified power, provide a showing that the utility will ensure that the amount of substitute energy purchases from unspecified resources is limited such that total purchases under the contract (renewable and non-renewable) will not exceed the total expected output from the renewable energy source over the term of the contract.

N/A – no firming and shaping is involved.

5. If substitute system energy from unspecified sources will be used, provide a showing that:

- a. the unspecified energy is only to be used on a short-term basis; and

N/A – no substitute energy is involved.

- b. the unspecified energy is only used for operational or efficiency reasons; and

N/A – no substitute energy is involved.

- c. the unspecified energy is only used when the renewable energy source is unavailable due to a forced outage, scheduled maintenance,

or other temporary unavailability for operational or efficiency reasons;
or

N/A – no substitute energy is involved.

- d. the unspecified energy is only used to meet operating conditions required under the contract, such as provisions for number of start-ups, ramp rates, minimum number of operating hours.

N/A – no substitute energy is involved.

I. Procurement Review Group (PRG) Participation

1. List PRG participants (by organization/company).

SDG&E's PRG is comprised of over fifty representatives from the following organizations:

- a. California Department of Water Resources
- b. California Public Utilities Commission – Energy Division
- c. California Public Utilities Commission – Division of Ratepayers Advocates
- d. The Utility Reform Network
- e. Union of Concerned Scientists
- f. Coalition of California Utility Employees

2. Describe the utility's consultation with the PRG, including when information about the contract was provided to the PRG, whether the information was provided in meetings or other correspondence, and the steps of the procurement process where the PRG was consulted.

SDG&E first notified its PRG at the February 17, 2012 meeting about the potential amendment to the PPA. The Proposed Agreement was discussed at the following PRG meeting dates:

December 14, 2012

April 19, 2013

3. For short term contracts, if the PRG was not able to be informed prior to filing, explain why the PRG could not be informed.

NA – not a short term contract

J. Independent Evaluator (IE)

The use of an IE is required by D.04-12-048, D.06-05-039, 07-12-052, and D.09-06-050

1. Name of IE

SDG&E's IE for renewable projects is PA Consulting.

2. Describe the oversight provided by the IE.

The IE works collaboratively with SDG&E to design the RFO and the LCBF process. The IE also performs an independent ranking of the RFO bids and double checks that SDG&E is applying the LCBF process

appropriately and that the SDG&E shortlist matches the IE shortlist. The IE monitors the progress of contract negotiations and, finally, prepares an independent report on the fairness of the negotiations and the value of the Proposed Agreement.

3. List when the IE made any findings to the Procurement Review Group regarding the applicable solicitation, the project/bid, and/or contract negotiations.

SDG&E does not keep minutes of the PRG meetings, but the IE did concur with the results of SDG&E's analysis of the Proposed Agreement as presented to the PRG. The IE's specific analysis and recommendations are included in the project-specific IE Report.

4. Insert the public version of the project-specific IE Report.

The public version of the project-specific IE Report appears at the end of Part 1 of this Advice Letter.

III. Project Development Status

The project was granted its Conditional Use Permit and Bureau of Land Management right-of-way in the fall of 2011. All transmission studies were also completed in 2011. The project expects to execute its interconnection agreement and secure its remaining permits by the end of 2013. Financing is scheduled to be completed in the fourth quarter of 2013.

IV. Contingencies and/or Milestones

Describe major performance criteria and guaranteed milestones, including those outside the control of the parties, including transmission upgrades, financing, and permitting issues.

The project needs to execute its EPC contract and then secure financing and launch construction. Prior to completion it will need to execute its Participating Generator Agreement and Meter Services Agreement with the CAISO. Once completed, the project will need to confirm its capacity and then declare COD. More detail on these milestones is provided in Confidential Appendix A of Part 2 of this Advice Letter.

V. Procedural Matters

A. Requested Relief

SDG&E respectfully requests that the Commission expedite its review and approval of the Proposed Agreement through the issuance of a resolution no later than July 31, 2013.

As detailed in this Advice Letter, SDG&E's entry into the Proposed Agreement and the terms of such agreements are reasonable; therefore, all costs associated with the Proposed Agreement, including for energy, green attributes, and resource adequacy, should be fully recoverable in rates.

The Proposed Agreement is conditioned upon Commission Approval. SDG&E, therefore, requests that the Commission include the following findings in its Resolution approving the Proposed Agreement:

1. The PPA, as amended by the Proposed Agreement, is reasonable and consistent with SDG&E's Commission-approved RPS Plan and; procurement from the PPA, as amended by the Proposed Agreement, will contribute towards SDG&E's RPS procurement obligation.
2. SDG&E's entry into the Proposed Agreement and the terms of such Proposed Agreement are reasonable; therefore, the Proposed Agreement is approved in its entirety and all costs of the purchase associated with the PPA, as amended by the Proposed Agreement, including for energy, green attributes, and resource adequacy are fully recoverable in rates over the life of the PPA, as amended by the Proposed Agreement, subject to Commission review of SDG&E's administration of the PPA, as amended by the Proposed Agreement.
3. Generation procured pursuant to the PPA, as amended by the Proposed Agreement, constitutes generation from eligible renewable energy resources for purposes of determining SDG&E's compliance with any obligation that it may have to procure eligible renewable energy resources pursuant to the California Renewable Portfolio Standard program (Public Utilities Code §§ 399.11, *et seq.* and/or other applicable law) and relevant Commission decisions.
4. The PPA, as amended by the Proposed Agreement, will contribute to SDG&E's minimum quantity requirement established in D. 12-06-038.

B. Protest

Anyone may protest this advice letter to the California Public Utilities Commission. The protest must state the grounds upon which it is based, including such items as financial and service impact, and should be submitted expeditiously. The protest must be made in writing and received no later than June 24, 2013, which is 21 days from the date this advice letter was filed with the Commission. There is no restriction on who may file a protest. The address for mailing or delivering a protest to the Commission is:

CPUC Energy Division
Attention: Tariff Unit
505 Van Ness Avenue
San Francisco, CA 94102

Copies should also be sent via e-mail to the attention of the Energy Division at EDtariffUnit@cpuc.ca.gov. It is also requested that a copy of the protest be sent via electronic mail and facsimile to SDG&E on the same date it is mailed or delivered to the Commission (at the addresses shown below).

Attn: Megan Caulson
Regulatory Tariff Manager
8330 Century Park Court, Room 32C
San Diego, CA 92123-1548
Facsimile No. 858-654-1879
E-Mail: MCaulson@semprautilities.com

C. Effective Date

This Advice Letter is classified as Tier 3 (effective after Commission approval) pursuant to GO 96-B. SDG&E respectfully requests that the Commission issue a final Resolution approving this Advice Letter on or before July 31, 2013.

D. Notice

In accordance with General Order No. 96-B, a copy of this filing has been served on the utilities and interested parties shown on the attached list, including interested parties in R.11-05-005, by either providing them a copy electronically or by mailing them a copy hereof, properly stamped and addressed.

Address changes should be directed to SDG&E Tariffs by facsimile at (858) 654-1879 or by e-mail to SDG&ETariffs@semprautilities.com.

CLAY FABER
Director – Regulatory Affairs

(cc list enclosed)

CALIFORNIA PUBLIC UTILITIES COMMISSION

ADVICE LETTER FILING SUMMARY ENERGY UTILITY

MUST BE COMPLETED BY UTILITY (Attach additional pages as needed)

Company name/CPUC Utility No. **SAN DIEGO GAS & ELECTRIC (U 902)**

Utility type:

ELC

GAS

PLC

HEAT

WATER

Contact Person: Joff Morales

Phone #: (858) 650-4098

E-mail: jmorales@semprautilities.com

EXPLANATION OF UTILITY TYPE

ELC = Electric

GAS = Gas

PLC = Pipeline

HEAT = Heat

WATER = Water

(Date Filed/ Received Stamp by CPUC)

Advice Letter (AL) #: 2487-E

Subject of AL: Request for Approval of Amended Renewable Power Purchase Agreement with CSolar IV West LLC

Keywords (choose from CPUC listing): Power Purchase Agreement

AL filing type: Monthly Quarterly Annual One-Time Other

If AL filed in compliance with a Commission order, indicate relevant Decision/Resolution #:

Does AL replace a withdrawn or rejected AL? If so, identify the prior AL: None

Summarize differences between the AL and the prior withdrawn or rejected AL¹: N/A

Does AL request confidential treatment? If so, provide explanation: See confidential Declaration

Resolution Required? Yes No

Tier Designation: 1 2 3

Requested effective date: 7/31/2013

NNo. of tariff sheets: 0

Estimated system annual revenue effect (%): N/A

Estimated system average rate effect (%): N/A

When rates are affected by AL, include attachment in AL showing average rate effects on customer classes (residential, small commercial, large C/I, agricultural, lighting).

Tariff schedules affected: None

Service affected and changes proposed¹: N/A

Pending advice letters that revise the same tariff sheets: None

Protests and all other correspondence regarding this AL are due no later than 20 days after the date of this filing, unless otherwise authorized by the Commission, and shall be sent to:

CPUC, Energy Division

Attention: Tariff Unit

505 Van Ness Ave.,

San Francisco, CA 94102

EDTariffUnit@cpuc.ca.gov

San Diego Gas & Electric

Attention: Megan Caulson

8330 Century Park Ct, Room 32C

San Diego, CA 92123

mcaulson@semprautilities.com

¹ Discuss in AL if more space is needed.

General Order No. 96-B
ADVICE LETTER FILING MAILING LIST

cc: (w/enclosures)

Public Utilities Commission

DRA

Y. Schmidt
W. Scott

Energy Division

P. Clanon
S. Gallagher
H. Gatchalian
D. Lafrenz
M. Salinas

CA. Energy Commission

F. DeLeon
R. Tavares

Alcantar & Kahl LLP

K. Harteloo

American Energy Institute

C. King

APS Energy Services

J. Schenk

BP Energy Company

J. Zaiontz

Barkovich & Yap, Inc.

B. Barkovich

Bartle Wells Associates

R. Schmidt

Braun & Blaising, P.C.

S. Blaising

California Energy Markets

S. O'Donnell
C. Sweet

California Farm Bureau Federation

K. Mills

California Wind Energy

N. Rader

CCSE

S. Freedman
J. Porter

Children's Hospital & Health Center

T. Jacoby

City of Chula Vista

M. Meacham
E. Hull

City of Poway

R. Willcox

City of San Diego

J. Cervantes
G. Lonergan
M. Valerio

Commerce Energy Group

V. Gan

Constellation New Energy

W. Chen

CP Kelco

A. Friedl

Davis Wright Tremaine, LLP

E. O'Neill
J. Pau

Dept. of General Services

H. Nanjo
M. Clark

Douglass & Liddell

D. Douglass
D. Liddell
G. Klatt

Duke Energy North America

M. Gillette

Dynegy, Inc.

J. Paul

Ellison Schneider & Harris LLP

E. Janssen

Energy Policy Initiatives Center (USD)

S. Anders

Energy Price Solutions

A. Scott

Energy Strategies, Inc.

K. Campbell
M. Scanlan

Goodin, MacBride, Squeri, Ritchie & Day

B. Cragg
J. Heather Patrick

J. Squeri

Goodrich Aerostructures Group

M. Harrington

Hanna and Morton LLP

N. Pedersen

Itsa-North America

L. Belew

J.B.S. Energy

J. Nahigian

Luce, Forward, Hamilton & Scripps LLP

J. Leslie

Manatt, Phelps & Phillips LLP

D. Huard
R. Keen

Matthew V. Brady & Associates

M. Brady

Modesto Irrigation District

C. Mayer

Morrison & Foerster LLP

P. Hanschen

MRW & Associates

D. Richardson

OnGrid Solar

Andy Black

Pacific Gas & Electric Co.

J. Clark
M. Huffman
S. Lawrie
E. Lucha

Pacific Utility Audit, Inc.

E. Kelly

R. W. Beck, Inc.

C. Elder

School Project for Utility Rate
Reduction

M. Rochman

Shute, Mihaly & Weinberger LLP

O. Armi

Solar Turbines

F. Chiang

Sutherland Asbill & Brennan LLP

K. McCrea

Southern California Edison Co.

M. Alexander

K. Cini

K. Gansecki

H. Romero

TransCanada

R. Hunter

D. White

TURN

M. Florio
M. Hawiger

UCAN

M. Shames

U.S. Dept. of the Navy

K. Davoodi

N. Furuta

L. DeLacruz

Utility Specialists, Southwest, Inc.

D. Koser

Western Manufactured Housing
Communities Association

S. Dey

White & Case LLP

L. Cottle

Interested Parties

R.11-05-005

San Diego Gas & Electric Advice Letter 2487-E
June 4, 2013

CONFIDENTIAL DECLARATION

**BEFORE THE PUBLIC UTILITIES
COMMISSION OF THE STATE OF CALIFORNIA**

**DECLARATION OF THEODORE E. ROBERTS REGARDING
CONFIDENTIALITY OF CERTAIN DATA**

I, Theodore E. Roberts, do declare as follows:

1. I am the Origination Manager for San Diego Gas & Electric Company (“SDG&E”). I have reviewed the attached Advice Letter No. 2487-E, including Confidential Appendices A, B, C, D, E, F, and G (the “Confidential Appendices”), and am personally familiar with the facts and representations in this Declaration. If called upon to testify, I could and would testify to the following based upon my personal knowledge and/or belief.

2. I hereby provide this Declaration in accordance with D.06-06-066, as modified by D.07-05-032, and D.08-04-023, to demonstrate that the confidential information (“Protected Information”) provided in the Responses submitted concurrently herewith, falls within the scope of data protected pursuant to the IOU Matrix attached to D.06-06-066 (the “IOU Matrix”).^{1/} In addition, the Commission has made clear that information must be protected where “it matches a Matrix category exactly . . . or consists of information from which that information may be easily derived.”^{2/}

^{1/} The Matrix is derived from the statutory protections extended to non-public market sensitive and trade secret information. (See D.06-06-066, *mimeo*, note 1, Ordering Paragraph 1). The Commission is obligated to act in a manner consistent with applicable law. The analysis of protection afforded under the Matrix must always produce a result that is consistent with the relevant underlying statutes; if information is eligible for statutory protection, it must be protected under the Matrix. (See *Southern California Edison Co. v. Public Utilities Comm.* 2000 Cal. App. LEXIS 995, *38-39) Thus, by claiming applicability of the Matrix, SDG&E relies upon and simultaneously claims the protection of Public Utilities Code §§ 454.5(g) and 583, Govt. Code § 6254(k) and General Order 66-C.

^{2/} See, *Administrative Law Judge’s Ruling on San Diego Gas & Electric Company’s April 3, 2007 Motion to File Data Under Seal*, issued May 4, 2007 in R.06-05-027, p. 2 (emphasis added).

3. I address below each of the following five features of Ordering Paragraph 2 in

D.06-06-066:

- That the material constitutes a particular type of data listed in the Matrix,
- The category or categories in the Matrix to which the data corresponds,
- That it is complying with the limitations on confidentiality specified in the Matrix for that type of data,
- That the information is not already public, and
- That the data cannot be aggregated, redacted, summarized, masked or otherwise protected in a way that allows partial disclosure.^{3/}

4. SDG&E's Protected Information: As directed by the Commission, The instant confidentiality request satisfies the requirements of D.06-06-066^{4/} because the information contained in the Confidential Appendices provided by SDG&E is of the type of information protected by the Matrix as follows:

Confidential Appendix A – Bid Information, Category VIII.A.; Specific Quantitative Analysis, Category VIII.B.; Contract Terms and Conditions, Category VII.G.; Total Energy Forecast, Category V.C.

Confidential Appendix B - Bid Information, Category VIII.A.; Specific Quantitative Analysis, Category VIII.B.

Confidential Appendix C - Bid Information, Category VIII.A.; Specific Quantitative Analysis, Category VIII.B.; Contract Terms and Conditions, Category VII.G.; Total Energy Forecast, Category V.C; Utility Bundled Net Open (Long or Short) Position for Energy (MWh), Category VI.B.

Confidential Appendix D - Contract Terms and Conditions, Category VII.G.; Specific Quantitative Analysis, Category VIII.B.

^{3/} D.06-06-066, as amended by D.07-05-032, *mimeo*, p. 81, Ordering Paragraph 2.

^{4/} See, *Administrative Law Judge's Ruling on San Diego Gas & Electric Company's Motions to File Data Under Seal*, issued April 30 in R.06-05-027, p. 7, Ordering Paragraph 3 ("In all future filings, SDG&E shall include with any request for confidentiality a table that lists the five D.06-06-066 Matrix requirements, and explains how each item of data meets the matrix").

Confidential Appendix E - Contract Terms and Conditions, Category VII.G.
Confidential Appendix F - Contract Terms and Conditions, Category VII.G.
Confidential Appendix G – Total Energy Forecast, Category V.C, Specific
Quantitative Analysis, Category VIII.B

5. As an alternative basis for requesting confidential treatment, SDG&E submits that the Power Purchase Agreement enclosed in the Advice Letter is material, market sensitive, electric procurement-related information protected under §§ 454.5(g) and 583, as well as trade secret information protected under Govt. Code § 6254(k). Disclosure of this information would place SDG&E at an unfair business disadvantage, thus triggering the protection of G.O. 66-C.^{11/}

6. Public Utilities Code § 454.5(g) provides:

The commission shall adopt appropriate procedures to ensure the confidentiality of any market sensitive information submitted in an electrical corporation's proposed procurement plan or resulting from or related to its approved procurement plan, including, but not limited to, proposed or executed power purchase agreements, data request responses, or consultant reports, or any combination, provided that the Office of Ratepayer Advocates and other consumer groups that are nonmarket participants shall be provided access to this information under confidentiality procedures authorized by the commission.

^{11/} This argument is offered in the alternative, not as a supplement to the claim that the data is protected under the IOU Matrix. California law supports the offering of arguments in the alternative. See, *Brandolino v. Lindsay*, 269 Cal. App. 2d 319, 324 (1969) (concluding that a plaintiff may plead inconsistent, mutually exclusive remedies, such as breach of contract and specific performance, in the same complaint); *Tanforan v. Tanforan*, 173 Cal. 270, 274 (1916) ("Since . . . inconsistent causes of action may be pleaded, it is not proper for the judge to force upon the plaintiff an election between those causes which he has a right to plead.")

7. General Order 66-C protects “[r]eports, records and information requested or required by the Commission which, if revealed, would place the regulated company at an unfair business disadvantage.”

8. Under the Public Records Act, Govt. Code § 6254(k), records subject to the privileges established in the Evidence Code are not required to be disclosed.^{5/} Evidence Code § 1060 provides a privilege for trade secrets, which Civil Code § 3426.1 defines, in pertinent part, as information that derives independent economic value from not being generally known to the public or to other persons who could obtain value from its disclosure.

9. Public Utilities Code § 583 establishes a right to confidential treatment of information otherwise protected by law.^{6/}

10. If disclosed, the Protected Information could provide parties, with whom SDG&E is currently negotiating, insight into SDG&E’s procurement strategies, which would give them an unfair negotiating advantage and could ultimately result in increased cost to ratepayers. In addition, if developers mistakenly perceive that SDG&E is not committed to assisting their projects, disclosure of the Protected Information could act as a disincentive to developers. Accordingly, pursuant to P.U. Code § 583, SDG&E seeks confidential treatment of this data, which falls within the scope of P.U. Code § 454.5(g), Evidence Code § 1060 and General Order 66-C.

11. Developers’ Protected Information: The Protected Information also constitutes confidential trade secret information of the developer listed therein. SDG&E

^{5/} See also Govt. Code § 6254.7(d).

^{6/} See, D.06-06-066, *mimeo*, pp. 26-28.

is required pursuant to the terms of the PPA to protect non-public information. Some of the Protected Information in the PPA relates directly to the viability of the project. Disclosure of this extremely sensitive information could harm the developer's ability to negotiate necessary contracts and/or could invite interference with project development by competitors.

12. In accordance with its obligations under its PPA and pursuant to the relevant statutory provisions described herein, SDG&E hereby requests that the Protected Information be protected from public disclosure.

I declare under penalty of perjury under the laws of the State of California that the foregoing is true and correct.

Executed this 4th day of June, 2013 at San Diego, California.

Theodore E. Roberts
Origination Manager
Electric & Fuel Procurement
San Diego Gas & Electric

San Diego Gas & Electric Advice Letter 2487-E

June 4, 2013

PART 2 – CONFIDENTIAL APPENDICES OF ADVICE LETTER

Confidential Appendix A
Consistency with Commission Decisions and Rules and Project
Development Status

All information contained in the Confidential Appendices is considered Confidential except where printed in italics. Italicized information contained in the Confidential Appendices is also included in Part 1 of this Advice Letter.

San Diego Gas & Electric Advice Letter 2487-E
June 4, 2013

Public Version of the Project Specific IE Report

San Diego Gas & Electric Co.

Report of the Independent Evaluator on the
Second Amendment to the 96 to 150 MW
CSolar Imperial Valley West contract relative
to the results of the 2009 Request for Offers
from Eligible Renewable Resources (2009
Renewable RFO)

May 29, 2013

San Diego Gas & Electric Co.

Report of the Independent Evaluator on the
Second Amendment to the 96 to 150 MW
CSolar Imperial Valley West contract
relative to the results of the 2009 Request
for Offers from Eligible Renewable
Resources (2009 Renewable RFO)

May 29, 2013

© PA Knowledge Limited 2011

Prepared by: Jonathan M. Jacobs

PA Consulting Group
Suite 3840, 38th Floor,
One California Plaza
300 South Grand Avenue,
Los Angeles, CA 90071, USA
Tel: +1 213 689 1515
Fax: +1 213 689 1129
www.paconsulting.com

Version: 1.3

San Diego Gas & Electric Co. 5/29/13

FOREWORD

This is PA Consulting Group's (PA's) Independent Evaluator (IE) Report analyzing the Second Amendment to the contract between San Diego Gas & Electric Company (SDG&E) and CSolar for a 96-150 MW photovoltaic project. This contract is based on a bilateral offer.

This report is styled as a revision to PA's report on the contract as amended by the First Amendment. That report was dated October 4, 2011. The amended contract was attached to SDG&E's Advice Letter 2257-E-A, filed October 3, 2011; the report was then attached to Advice Letter 2257-E-A, filed October 4, 2011. The October 2011 report was a revision to a report dated May 23, 2011, which was attached to SDG&E's Advice Letter 2257-E, dated May 27, 2011.

The report was based on PA Consulting Group's Preliminary Report on the 2009 RFO. The Preliminary Report addressed the conduct and evaluation of San Diego Gas & Electric Company's 2009 Renewables RFO through the selection of its preliminary short list. This report contains all the text of the Preliminary Report except for placeholder text in chapters 6 and 7.

The CPUC requires an IE report accompany any bilateral contract submitted for approval, and the template provided by the CPUC relates to RFOs. Since this contract was not submitted into any RFO, PA based its report upon its IE report for the most recently completed RPS RFO as of the time of writing (the 2009 RPS RFO). CPUC Resolution E-4199 states that contract repricings should always be compared to the most recent MPR. The October 2011 revision, while based on the report for the 2009 RFO, also references the results of the then recently completed 2011 RFO. This report in turn references the results of the now recently completed (and not yet filed) 2013 RFO.

In the body of the report (that is, except for this Foreword), text from the October 2011 Report is in gray while new text is presented in black. This should help the reader identify the new text.

This report contains confidential and/or privileged materials. Review and access are restricted subject to PUC Sections 454.5(g), 583, D.06-06-066, GO 66-C and the Confidentiality Agreement with the CPUC.

TABLE OF CONTENTS

Foreword	i
1. Introduction	1-1
2. Role of the Independent Evaluator (IE)	2-1
2.1 The IE requirement	2-1
2.2 PA’s role as Independent Evaluator	2-3
2.3 PA’s activities	2-4
2.4 Confidentiality and additional comments	2-4
3. Adequacy of outreach and robustness of the solicitation	3-1
3.1 Solicitation materials	3-1
3.2 Adequacy of outreach	3-1
3.3 Solicitation robustness	3-2
3.4 Feedback	3-2
3.5 Additional issues	3-2
4. Fairness of the design of SDG&E’s methodology for bid evaluation and selection	4-1
4.1 Principles used to evaluate methodology	4-1
4.2 SDG&E’s LCBF methodology	4-2
4.3 Evaluation of the strengths and weaknesses of SDG&E’s LCBF methodology in this solicitation	4-4
4.4 Future improvements	4-5
4.5 Additional comment on the methodology	4-6
5. Procedural fairness of the bid evaluation	5-1
5.1 Principles used to determine fairness of process	5-1
5.2 Administration and bid processing	5-2
5.3 Conformance check	5-2
5.4 Parameters and inputs for SDG&E’s analysis	5-3
5.5 Parameters and inputs for outsourced analysis	5-3
5.6 Transmission analysis	5-3
5.7 Additional issues	5-4
5.8 Results analysis	5-5
5.9 Additional issues	5-7
6. Fairness of project-specific negotiations	6-1
6.1 Principles of evaluation	6-1
6.2 Project-specific negotiations	6-1
6.3 Terms and conditions	6-2
6.4 Relation to other negotiations	6-2

6.5	Additional issues	6-3
7.	Project-specific recommendation	7-1
7.1	Evaluation	7-1
7.2	Recommendation	7-7
7.3	Additional issues	7-10

1. INTRODUCTION

PA Consulting Group, Inc. (PA) has served as the Independent Evaluator (IE) of San Diego Gas & Electric Co.'s (SDG&E's) 2009 Request for Offers from Eligible Renewable Resources (2009 Renewable RFO). This Report provides PA's evaluation of the fairness of the solicitation, up to and including the identification of a "short list" of bidders with whom SDG&E may pursue contract negotiations. This document has been formatted in accord with a template provided by Cheryl Lee of the CPUC Energy Division in an email dated Oct. 27, 2009.

2. ROLE OF THE INDEPENDENT EVALUATOR (IE)

Template language: "Describe the IE's role."

This chapter describes the history of the requirements for Independent Evaluators at the Federal level and in California. It includes a list of the roles of the IE as well as a summary of PA's activities in fulfilling those roles.

2.1 THE IE REQUIREMENT

Template language: "Cite CPUC decisions requiring IE participation in RPS solicitations: D.04-12-048 (Findings of Fact 94-95, Ordering Paragraph 28) and D.06-05-039 (Finding of Fact 20, Conclusion of Law 3, Ordering Paragraph 8)."

Regulatory requirements for an IE of resource procurement can be traced to the Federal Energy Regulatory Commission's (FERC's) "Opinion and Order ... Announcing New Guidelines for Evaluating Section 203 Affiliate Transactions" (108 FERC ¶ 61,081 (2004)). That decision addressed ways to demonstrate that a utility's procurement of power from an affiliate was not abusive or unfair, under the standards of the *Edgar* decision (55 FERC ¶ 61,382 (1991)). FERC provided a set of guidelines, which presumably would be sufficient to demonstrate that the utility had not unfairly favored its affiliate. One of those guidelines was that "an independent third party should design the solicitation, administer bidding, and evaluate bids prior to the company's selection." FERC proposed not just independent evaluation but independent conduct of all aspects of the solicitation (except, presumably, the need determination).

The California Public Utilities Commission (CPUC) referenced those guidelines in its December 2004 decision on long-term resource procurement.¹ The CPUC stated that although it had not previously required the use of an IE for resource procurement, it would "require the use of an IE in resource solicitations where there are affiliates, IOU-built, or IOU-turnkey bidders" from that point forward.² The CPUC's intention was clearly that the IE should ensure that the utility did not favor itself, its affiliates or its shareholders (shareholders would earn a return on "ownership projects" – IOU-built or turnkey – but not on independent PPAs). The CPUC stated explicitly that it would not require the IE to conduct or administer the solicitation, nor would it "allow the IEs to make binding decisions on behalf of the utilities." Under this decision the role of the IE is to provide advice to the utility in "the design, administration, and evaluation aspects of the RFO" and to observe the utility's procurement and evaluation process in order to provide a fairness opinion.

D. 04-12-048 did not require IEs for procurements in which there were no affiliate or ownership bids. But in its decision approving the utilities' plans for 2006 Renewable Portfolio Standard (RPS) solicitations, the CPUC determined that Independent Evaluators would be required for these and "all future solicitations" (it is unclear whether this means only all future

¹ California Public Utilities Commission, Decision (D.) 04-12-048, May 26, 2006, p. 135f and Findings of Fact 94-95 on pp. 219-220.

² D. 04-12-084, p. 135f and Ordering Paragraphs 26i and 28 on p. 245.

2. Role of the Independent Evaluator (IE)

RPS solicitations).³ The role of the IE is still not to conduct or administer the solicitation but to “separately evaluate and report on the IOU’s entire solicitation, evaluation and selection process”.⁴ The Decisions that approved the utility RPS solicitation plans for 2007 and 2008⁵ did not further elaborate on the IE role but took the participation of an IE as a given.

D. 09-06-018, which approved the utility RPS solicitation plans for 2009, contained additional requirements related to the use of Project Viability Calculators and directed “that project-specific project viability information should be included in the confidential appendices to advice letters and validated by the IE in the confidential versions of IE reports.”⁶ The reference to the Project Viability Calculator has been incorporated by Energy Division in its template language for Section 7, which is only completed in the final IE report submitted with each contract Advice Letter.

D. 09-06-050, which was primarily concerned with the definition of a “fast-track” procedure for selecting and approving short-term renewable contracts, also clarified the procedure for approving bilateral contracts. It specifies that “long-term bilateral contracts should be reviewed according to the same processes and standards as contracts that come through a solicitation. This includes review by the utility’s Procurement Review Group and its Independent Evaluator.”^{6A} This section of the decision does not specify that a bilateral contract should be reviewed in the context of an RFO, although the IE report template distributed by the Energy Division only apply to RFOs (Energy Division also distributed a template for a “short form” report related to the special approval procedure for short-term contracts).

CPUC Resolution E-4199 clarifies the treatment of contract amendments that affect pricing. Proposed repricings should always be compared to the most recent MPR. The Commission is also expressly concerned that price amendments should only respond to changes in the developer’s costs, and not provide extra profits, and therefore the Commission requires the developer to provide cash flow models for the original contract and the repricing in order to allow Energy Division and the IE to verify that developer profits have not increased. In all other cases the IE is only supposed to opine upon the relationship of the contract to the market.^{6B}

³ California Public Utilities Commission, Decision (D.) 06-05-039, May 26, 2006, p. 46, Finding of Fact 20b on p. 78, Conclusion of Law 3e(2) on p. 82 and Ordering Paragraph 8 on p. 88.

⁴ D. 06-05-039, p. 46.

⁵ California Public Utilities Commission, Decision (D.) 07-02-011, Feb. 15, 2007 and Decision (D.) 08-02-008, Feb. 15, 2008. The decisions actually only conditionally approved the plans but the conditions were not connected with the use of IEs.

⁶ California Public Utilities Commission, Decision (D.) 09-06-018, June 8, 2009, p. 24.

^{6A} California Public Utilities Commission, Decision (D.) 09-06-050, June 19, 2009, p. 28f.

^{6B} California Public Utilities Commission, Resolution E-4199, March 12, 2009.

This report deals with a project that was not bid into SDG&E's 2009 RPS RFO. As a bilateral contract, it should be evaluated relative to the most recent RPS RFO. Therefore, PA is evaluating this contract as if it had been bid into the 2009 RFO.

2.2 PA'S ROLE AS INDEPENDENT EVALUATOR

Template language: "Description of key IE roles: IEs provide an independent evaluation of the IOU's RPS bid evaluation and selection process:

- "1. Did the IOU do adequate outreach to potential bidders and was the solicitation robust?*
- "2. Was the IOU's LCBF methodology designed such that all bids were fairly evaluated?*
- "3. Was the IOU's LCBF bid evaluation and selection process fairly administered?*
- "4. Did the IOU make reasonable and consistent choices regarding which bids were brought to CPUC for approval?"*

In April 2006, SDG&E retained PA to be the Independent Evaluator for an All-Source Request for Offers (All-Source RFO). SDG&E anticipated that there might be affiliate bids in that RFO, as in fact there were. The CPUC Energy Division, as well as the rest of SDG&E's Procurement Review Group (PRG), participated in the decision to select PA. PA's contract was subsequently amended to include the independent evaluation of additional SDG&E procurement activities.

When PA was contracted as IE for the All-Source RFO, PA and SDG&E agreed on an interpretation of the IE role that would not include a complete LCBF evaluation or full replication of the utility's computations, although PA would spot-check them. PA's role would be that of an observer and an adviser as needed. PA subsequently served as Independent Evaluator for SDG&E's 2006 Renewable RFO and the Local Peaker RFO (conducted in 2006-7). In each case, PA and SDG&E used the above interpretation of the IE role, and it was adopted for the 2009 Renewables RFO.

PA's emphasis has been on issues of fairness and equity. PA reviews the reasonableness of SDG&E's evaluation criteria and algorithms and spot-checks the calculations but does not enforce a single standard of evaluation. While PA may have an opinion about the "best" way to value certain attributes or even to conduct a multi-attribute evaluation, its role as IE has not been to judge SDG&E's evaluation against a standard, but rather to determine that SDG&E's evaluation has not unfairly favored affiliates or ownership bids, or favored SDG&E and its shareholders in any other way⁷.

For the 2009 RFO, SDG&E also asked PA to conduct the quantitative LCBF evaluation of bids, except for the congestion adder computation. This was a direct response to experience of past RFOs, and the efforts that SDG&E had to make to avoid any appearance of conflict in its evaluation of affiliate bids. PA also determined the TRCR clusters, and hence TRCR

⁷ E.g., it would have been unfair for SDG&E to design an evaluation method that favored a category of bidders on whose behalf SDG&E would have to make extensive rate-based transmission or distribution investments.

costs, in cases where the bidder had not specified them. PA's approach to conducting this evaluation was consistent with its approach to reviewing SDG&E's evaluation: the criteria to be applied were SDG&E's, not PA's, the spreadsheet model used to apply those criteria had been developed by SDG&E, and PA ensured that the criteria and model were reasonable and then applied them. PA did not itself determine the evaluation standards but PA did advise SDG&E on the definition and refinement of the evaluation criteria.

2.3 PA'S ACTIVITIES

Template language: "Description of activities undertaken by the IE to fulfill the IE's role (i.e. attended negotiation meetings, reviewed Request for Proposals materials, attended pre-bid conference, evaluated proposals and/or reviewed evaluation process and results, etc.) and reporting/consultation with CPUC, PRG and others."

PA and SDG&E began to discuss plans for the 2009 RFO during and after the 2008 RPS RFO evaluation, including the possibility of PA conducting the LCBF evaluation. SDG&E provided PA the draft RPS plan for review prior to its filing, and PA responded with a number of specific comments based on past experience. SDG&E and PA discussed several of these areas at length, most notably the treatments of duration equivalence and resource adequacy. SDG&E adopted several of PA's suggestions and declined to adopt others. In all these cases SDG&E's decisions were reasonable (even if they were to disagree with PA).

PA was provided access to all the SDG&E staff involved in the evaluation of the Renewables RFO. In general, the bid evaluation criteria were similar to those that had been used in past RFOs. PA met with SDG&E to review the evaluation criteria and reviewed the LCBF model constructed by SDG&E.

PA was present at both bidder conferences: in San Diego on August 5 and in El Centro on August 12. PA was provided all questions submitted by bidders either at the bidder conference or later in writing, as well as SDG&E's answers. PA received the electronic bids from SDG&E in San Diego on both days bids were due.

PA was in regular contact with the SDG&E evaluation team. PA was provided all the data in the evaluation process. PA was responsible for interpreting all bids in order to conduct the LCBF evaluation. PA identified missing or incomplete information, including viability scorecards, and requested additional data from bidders. PA also reviewed questions put by SDG&E to bidders, and bidders' answers. PA advised SDG&E on judgments that certain bids did not conform to RFO requirements. PA participated in Procurement Review Group (PRG) meetings during the evaluation period. SDG&E discussed the short list with PA as well as with the PRG.

SDG&E in no way prevented PA from observing its process and analyzing its methods, and did not interfere with PA's conduct of the LCBF evaluation.

2.4 CONFIDENTIALITY AND ADDITIONAL COMMENTS

Template language: "Any other relevant information or observations."

2. Role of the Independent Evaluator (IE)

PA

It is PA's understanding that confidential treatment of the information in an IE report is obtained through procedures defined in CPUC Rulemaking (R.) 05-06-040.⁸ Under that Ruling a person or party that serves testimony, supplies data or files an advice letter requests confidential treatment of some data within that submittal and must accompany the data by a declaration under penalty of perjury that justifies the claim of confidentiality.

PA delivers its IE report to SDG&E and SDG&E in turn submits it to the CPUC. It is PA's understanding that each utility separately submits its IE's report and requests confidential treatment for parts of that report. Because it is the utility that identifies confidential data and provides the associated declaration, PA believes that it is the utility's right to determine which data in the report is confidential and the utility's responsibility to defend that determination. SDG&E's view of confidentiality may be more or less expansive than PA's. While PA has in the past provided recommendations to SDG&E about which parts of its IE reports should be held confidential, in general PA takes a "minimal redaction" (redaction only of information about identifiable bids) view. SDG&E always makes the ultimate determination of data to redact.

⁸ "Administrative Law Judge's Ruling Clarifying Interim Procedures for Complying with Decision 06-06-066", August 22, 2006.

3. ADEQUACY OF OUTREACH AND ROBUSTNESS OF THE SOLICITATION

Template language: “Did the IOU do adequate outreach to bidders and was the solicitation robust?”

This chapter describes the information provided by the utility to potential bidders, and the utility’s efforts to stimulate a wide and robust response to the RFO.

3.1 SOLICIATION MATERIALS

Template language: “Were the solicitation materials clear and concise to ensure that the information required by the utility to conduct [sic] its evaluation was provided by the bidders?”

PA reviewed SDG&E’s RFO and supporting forms. PA’s opinion was that the RFO was clear and supporting forms were generally well-designed and would elicit appropriate information except as noted in the next paragraph. Even so, not all bidders entered data correctly and completely, but PA does not believe this was the fault of the forms.

SDG&E held two pre-bid conferences, in San Diego and El Centro, and also posted on its website answers to questions submitted by bidders. Even so, the solicitation forms and posted responses did not always elicit the type of information required by the Project Viability Calculator. In particular, the PVC scoring criteria are based on specific information – e.g., identification of projects to support assertion of project development experience, or an explanation of why a particular interconnection milestone with IID is or is not equivalent to a CAISO milestone.

3.2 ADEQUACY OF OUTREACH

Template language: “Identify guidelines used to determine whether IOU did adequate outreach (e.g., sufficient publicity, emails to expected interested firms). Did IOU do adequate outreach? If not, explain how it was deficient.”

California’s Renewable Procurement Standard and its utilities’ attempts to meet that standard have been widely publicized. The investor-owned utilities have conducted annual RFOs for renewable resources for several years. Because of the publicity, it should not have been necessary for SDG&E to take on the responsibility of informing bidders that California has a renewables program or that utilities would be contracting with renewable suppliers. Furthermore, it was well-known in the California energy industry that at the time of the adoption of the RPS, SDG&E was the furthest of the three utilities from satisfying the RPS (least renewable energy relative to retail sales). It would have been adequate for SDG&E to advertise the RPS solicitation on its website and to a sizable email list.

In PA’s opinion, SDG&E did adequate outreach. SDG&E provided PA with a list of 686 email addresses, associated with 545 separate organizations, to which it sent the RFO. Some of those addresses are consultants probably not working with any particular bidder. In addition, SDG&E publicized the RFO with a press release, and notices appeared in Platt’s *MW Daily* and *California Energy Markets*.

3.3 SOLICITATION ROBUSTNESS

Template language: "Identify guidelines used to determine adequate robustness of solicitation (e.g., number of proposals submitted, number of MWhs associated with submitted proposals). Was solicitation adequately robust?"

PA judges the robustness of the solicitation by the number of bids received. In PA's opinion, the solicitation engendered a robust response. 56 separate organizations responded to the solicitation with a total of 158 project proposals with 289 pricing options. The CPUC had encouraged SDG&E to do specific outreach to the Imperial Valley and, more generally, the SPL area. 34 project proposals were submitted from the SPL area, with 67 pricing options, from a total of 22 separate bidders.

3.4 FEEDBACK

Template language: "Did the IOUs seek adequate feedback about the bidding/bid evaluation process from all bidders after the solicitation was complete?"

SDG&E did not formally seek bidder feedback.

3.5 ADDITIONAL ISSUES

Template language: "Any other relevant information or observations"

PA has nothing else to add to this chapter.

4. FAIRNESS OF THE DESIGN OF SDG&E'S METHODOLOGY FOR BID EVALUATION AND SELECTION

Template language: "Was the IOU's LCBF methodology designed such that bids were fairly evaluated?"

This chapter describes SDG&E's quantitative evaluation methodology and PA's opinion of its application.

4.1 PRINCIPLES USED TO EVALUATE METHODOLOGY

Template language: "Identify the principles the IE used to evaluate the IOU's bid evaluation methodology. Example principles (each IE should include the specific principles he/she used in his/her evaluation):

"1. The IOU bid evaluation should be based only on information submitted in bid proposal documents.

"2. There should be no consideration of any information that might indicate whether the bidder is an affiliate.

"3. Procurement targets and objectives were clearly defined in IOU's solicitation materials.

"4. The IOU's methodology should identify quantitative and qualitative criteria and describe how they will be used to rank bids. These criteria should be applied consistently to all bids.

"5. The LCBF methodology should evaluate bids in a technology-neutral manner.

"6. The LCBF methodology should allow for consistent evaluation and comparison of bids of different sizes, in-service dates, and contract length."

PA has used the following principles to guide its evaluation. These principles were originally codified by PA in its report on SDG&E's 2006 RPS RFO:⁹

ffi The evaluation should only be based on those criteria requested in the response form. There should be no consideration of any information that might indicate whether the bidder is an affiliate.

ffi The methodology should identify how quantitative measures will be considered and be consistent with an overall metric.

ffi The approach should not be biased for or against specific technologies, solely based on the choice of technology (as opposed to, e.g., quantifiable differences between the value of peaking and baseload technologies).

⁹ Jacobs, Jonathan M., *Preliminary Report of the Independent Evaluator on the 2006 Request for Offers from Eligible Renewable Resources (Renewable RFO)*, PA Consulting Group, Los Angeles CA, January 16, 2007, p. 2-1.

- ffi The methodology does not have to be the one that the IE would independently have selected but it needs to be “reasonable”.

These principles do not require the upfront identification of procurement targets, as those may depend on committed contract quantities and commitments may be made between release of the RFO and selection of the shortlist. They do not also specifically address “consistent” evaluation of bids of different sizes and timing because PA considers the fairness of such analysis to fall within the area of reasonableness; and it is conceivable that a consistent evaluation may not be the most reasonable.

4.2 SDG&E'S LCBF METHODOLOGY

Template language: “Describe IOU LCBF methodology.”

SDG&E ranked bids using a spreadsheet. The following quantitative values went into the ranking:

- ffi Adjusted, levelized offer price
- ffi Estimated costs of transmission network upgrades or additions
- ffi Estimated congestion costs
- ffi Estimated RA credit

Debt equivalence was not considered, per CPUC D. 07-12-052. The next four subsections describe the four bullet items above. The fifth subsection addresses a specific change to one of the details of the LCBF calculation relative to previous renewable RFOs. PA's opinion of the use of LCBF methodology is included in section 5.8.

4.2.1 Adjusted, levelized offer price

SDG&E's bid evaluation method does not directly compare costs and benefits of individual contracts; rather it creates an “adjusted price” metric for each contract, and compares contracts based on that metric rather than on a measure of net benefits or net costs. This means that SDG&E does not compute an “avoided cost” or “market price” by hour or subperiod to be compared with contract costs. Such a computation would be appropriate if the source of contract value was energy value (avoided energy purchases). But RPS-qualified energy is not interchangeable or fungible with spot energy, because spot energy is not guaranteed to be RPS-qualified.

The benefit or value of RPS-qualified energy is in its renewability. In that sense every MWh from a renewable resource has equal benefit regardless of the contract or the time of delivery. But SDG&E also recognized that RPS-qualified energy has both “renewability value” and “energy value”, and that the energy value depends on time of delivery (TOD). To recognize this, SDG&E uses as its measure of contract cost the average of the projected contract payments in different TOD periods weighted by the product of volume and a TOD weighting factor. The weighting factors have been approved by the CPUC and PA did not investigate their source.

For each year, the adjusted or “benefit-weighted” price is the average payment, divided by a MWh-weighted average TOD factor. For contracts with TOD pricing (where in each period

the payment per MWh equals the contract price times the TOD factor) it is the same as the contract price. The offer price term is the levelization of the adjusted price: for each year, the adjusted price in \$/MWh is multiplied by projected deliveries in MWh to get a stream of revenues, and the offer price term is the constant price in \$/MWh that would yield a stream of energy revenues having the same net present value.

4.2.2 Estimated costs of transmission network upgrades or additions

For offers for new projects or projects proposing to increase the size of existing facilities, SDG&E's model calculated costs for transmission network upgrades or additions, using the information provided through the TRCRs. (Two projects had CAISO-approved, completed System Impact Studies that could have been used but since they were ranked below the shortlist cutoff before adding any transmission costs, this specialized effort was not undertaken.) If a bidder identified the cluster to which a project belonged, the transmission cost corresponded to the cost of the first plant in that cluster according to the utility's TRCR. If the bidder had not identified the cluster, PA applied its own judgment to determine the cluster based on the project location and interconnection information. Projects outside of the California ISO were expected to have internalized the cost of transmission to the ISO, as well as the cost of required transmission upgrades outside the ISO, into their bid price; they could still be assigned additional upgrade costs within California based on the TRCRs.

4.2.3 Estimated congestion costs

Congestion impacts from the proposed point of delivery to SDG&E's load aggregation point were determined after LCBF rankings had been computed without congestion information. In this way SDG&E was able to reduce the number of projects for which congestion impacts were computed. In past RFOs the congestion study had been conducted by ABB Inc. ABB was unable to do so for the 2009 study. PA agreed that it was reasonable for SDG&E's transmission planning group to conduct the study given the separation from the procurement group provided for under the FERC Code of Conduct. As for the 2008 RFO, there was no pre-Sunrise case. Congestion adders for the projects that ranked highest based on the other LCBF components were all small and therefore congestion costs did not affect the composition of the short list.

4.2.4 RA credit

Renewable projects under contract to SDG&E would provide varying amounts of resource adequacy (RA) credit. In the 2008 RPS RFO for which PA served as IE, SDG&E had represented RA as a cost rather than a credit, based on the cost SDG&E would incur for additional RA credits equal to the difference between a bid's capacity and its own RA credit. PA argued that this approach unduly relied on a bid's "nameplate" capacity, which had no real relation to any commodity the bid provided to SDG&E and which could in some cases be an artificial value. SDG&E accepted PA's argument for the 2009 RFO and assigned each bid a cost credit equal to the value of the RA credit the bid would be expected to receive based on technology and the RA capacity credits that have been assigned by CAISO to projects of similar technology (normalized by capacity). The result is an annual RA credit in \$/year (a unit cost in \$/kW-yr multiplied by capacity in kW). The credit is converted to levelized \$/MWh, similar to the levelization of the offer price term.

4.2.5 Duration equalization

In past Renewables RFOs, SDG&E used a "duration equalization" approach to handle start and end effects. This has addressed principle 6 from the Template (section 4.1). All contracts were put on an equal term basis by using an early start date (in principle, the earliest start date over all bids) and a late end date (in principle, the latest end date over all bids). The pricing for each contract prior to its start date and after its end date was based on an MPR proxy, that is, a value computed using the CPUC's MPR methodology applied to contemporary cost assumptions. For the 2009 RFO, SDG&E's evaluation model was constructed to use the average bid price of bids shortlisted in 2008 as a proxy instead of the MPR; all other aspects of the design were the same as before.

4.3 EVALUATION OF THE STRENGTHS AND WEAKNESSES OF SDG&E'S LCBF METHODOLOGY IN THIS SOLICITATION

Template language: "Using the principles indentified in section III.A, evaluate the strengths and weaknesses of IOU's methodology in this solicitation:

- "1. Market valuation
- "2. Evaluation of various technologies and products
- "3. Evaluation of portfolio fit
- "4. Evaluation of bids with varying sizes, in-service dates, and contract length
- "5. Evaluation of bids' transmission costs
- "6. Evaluation of bids' project viability
- "7. Other."

Overall, PA believes that the SDG&E methodology is reasonable. This judgment is within the context of the principles set forth in 4.1, especially the last: "The methodology does not have to be the one that the IE would independently have selected but it needs to be 'reasonable'." PA has detailed comments on a limited number of the points above.

4.3.1 Evaluation of various technologies and products

PA did not detect any technology bias in the methodology; however there were certain biases present in the qualitative evaluation which should be mentioned.

First, SDG&E preferentially selected bids in the Imperial Valley or "SPL area". This is consistent with other commitments SDG&E has made, for example to replace failed projects with projects from the SPL area. This geographic bias had no technology component and comports with the CPUC's policy directive to encourage development in the Imperial Valley. PA believes that it is reasonable for SDG&E to exercise such a bias provided that it is does not depend on the identities of bidders, and that SDG&E only uses it to distinguish among projects of substantially similar LCBF rankings.



PA disagreed with this decision but did not strongly advocate against it, because it was a legitimate exercise of SDG&E's judgment.

4.3.2 Evaluation of portfolio fit

The Renewable Portfolio Standard is based on raw renewable MWh, with no time differentiation. Furthermore, the quantitative LCBF analysis is but part of a process that includes consideration of bidders' track records and viability and extensive negotiation – another IE has characterized the process as more like a “competitive negotiation” rather than a sealed-bid auction.¹⁰ SDG&E's LCBF computation bears a similar relation to a more complex time-differentiated analysis as a “screening curve” analysis does to an optimal capacity expansion model; yet as a part of a larger process the screening curve analysis is often quite adequate.

4.3.3 Evaluation of bids' transmission costs

PA assigned TRCR clusters to those projects that did not provide such information. PA did not consider SCE's TRCR to contain a sufficient definition of its clusters, and requested additional information, which was received from an SCE attorney. In mid-August, PA was informed that SDG&E's procurement group was considering requesting from its transmission planning group a special TRCR-like upgrade analysis for Imperial Valley resources, but if such a study was conducted its results were not used in the LCBF evaluation. SDG&E's Evaluation Team requested a congestion analysis from SDG&E's Transmission function; PA reviewed the information provided by the Evaluation Team and ensured that no data was transmitted that could identify bidders.

4.3.4 Evaluation of bids' project viability

SDG&E eliminated certain bids due to low viability. These judgments did not always accord with bidders' Project Viability Calculators, which had been self-scored. It was necessary to rescore all high-ranking bids. In one case SDG&E relied on its own experience analyzing and eliminating a potential developer site that was subsequently bid into the 2009 RFO.

4.4 FUTURE IMPROVEMENTS

Template language: “What future LCBF improvements would you recommend?”

PA has no improvements to recommend at this time.

¹⁰ Private conversation.

4. Fairness of the design of SDG&E's methodology for bid evaluation and selection

4.5 ADDITIONAL COMMENT ON THE METHODOLOGY

Template language: "Any additional information or observations regarding the IOU's evaluation methodology."

PA has nothing else to add to this chapter.

5. PROCEDURAL FAIRNESS OF THE BID EVALUATION

Template language: "Was the LCBF bid evaluation process fairly administered?"

This chapter addresses the application or administration of the methodology described in chapter 4

5.1 PRINCIPLES USED TO DETERMINE FAIRNESS OF PROCESS

Template language: "A. Identify guidelines used to determine fairness of evaluation process. Example guidelines (each IE should identify the specific guidelines he/she used in his/her evaluation)

1. *Were all bids treated the same regardless of the identity of the bidder?*
2. *Were bidder questions answered fairly and consistently and the answers made available to all bidders?*
3. *Did the utility ask for "clarifications" that provided one bidder an advantage over others?*
4. *Was the economic evaluation of the bids fair and consistent?*
5. *Was there a reasonable justification for any fixed parameters that were a part of the IOU's LCBF methodology (e.g., RMR values; debt equivalence parameters)?*
6. *What qualitative and quantitative factors were used to evaluate bids?"*

As in the previous section, PA used principles originally codified by PA in its report on SDG&E's 2006 RPS RFO:¹¹

- ffi *Were affiliate bids treated the same as non-affiliate?*
- ffi *Were bidder questions answered fairly and consistently and the answers made available to all?*
- ffi *Did the utility ask for "clarifications" that provided the bidder an advantage over others?*
- ffi *Were bids given equal credibility in the economic evaluation?*
- ffi *Was the procurement target chosen so that SDG&E would have a reasonable chance of meeting its 20% target (taking into account contract failures)?*
- ffi *Was there a reasonable justification for any fixed parameters that enter into the methodology (e.g., RMR values; debt equivalence parameters)?*
- ffi *Were qualitative factors used only to distinguish among substantially equal bids?*

¹¹ Jacobs, op. cit., p. 3-1.

5.2 ADMINISTRATION AND BID PROCESSING

Template language: "Utilizing the guidelines in Section IV.A, describe the IE methodology used to evaluate administration of the IOU LCBF process."

A complete description of PA's activities is in section 2.3. Most of the guidelines above are addressed in detail in subsequent sections of this chapter, but three of them, which are not addressed below, can be answered here succinctly:

- Bidder questions were answered fairly and consistently.
- SDG&E did not ask for clarifications in such a way as to advantage any bidder.
- All bids were given equal credibility in the quantitative (LCBF) evaluation.

5.3 CONFORMANCE CHECK

Template language: "Did the utility identify, for each bid, the terms that deviate from the utility RFO? Did the IOU identify nonconforming bids fairly – fair both to the nonconforming bidders and to conforming bidders?"

PA verified that each offer received conformed with the requirements of the RFO. Nonconforming bids were identified as such but not immediately discarded. As in previous renewables solicitation, the RFO stated that non-conformance "may disqualify [a] proposal from further consideration". SDG&E and PA interpreted this somewhat broadly and attempted to evaluate the nonconforming bids if possible. Extensive efforts were made to contact bidders and give them opportunities to provide additional information that would bring their bids into conformance. PA recommended that SDG&E eliminate a small number of offers as non-conforming:

- [REDACTED]
- [REDACTED]
- [REDACTED]
- [REDACTED]

In addition, several offers including "negotiation prices" or unspecified "SDG&E participation" in development were eliminated as being incompletely priced. In each case, these were

additional options associated with PPA offers, so that the projects themselves were not eliminated.

PA believes that SDG&E's treatment of non-conforming bids was fair and reasonable.

5.4 PARAMETERS AND INPUTS FOR SDG&E'S ANALYSIS

Template language: "If the IOU conducted any part of the bid evaluation, were the parameters and inputs determined reasonably and fairly? What controls were in place to ensure that the parameters and inputs were reasonable and fair?"

The quantitative bid analysis was conducted by PA. Certain key parameters were supplied by SDG&E independent of any bids, including the RA price estimate, RA cost factors, the proxy price for duration equalization, TOU pricing factors, and financial parameters of the revenue requirements model for Alternative III bids. Parameters and inputs for the congestion analysis were determined by SDG&E's transmission function independent of the procurement group.

5.5 PARAMETERS AND INPUTS FOR OUTSOURCED ANALYSIS

Template language: "If the IE or a third party conducted any part of the bid evaluation, what information/data did the utility communicate to that party and what controls did the utility exercise over the quality or specifics of the out-sourced analysis?"

PA conducted the quantitative LCBF analyzing using a spreadsheet model and parameters supplied by SDG&E. SDG&E and PA were in communication throughout the analysis, generally about modifications to the model that became necessary in the course of the analysis and about missing data. SDG&E did not exercise control over the quality or specifics of the analysis. SDG&E and PA did work together to identify and solicit missing information from bidders.

Congestion impacts from the proposed point of delivery to SDG&E's load aggregation point were determined by a study conducted by SDG&E's transmission function. SDG&E's procurement group communicated to the transmission function the locations and general characteristics of a set of high-ranking bids for this analysis. PA reviewed that communication to ensure it included no identifying information.

5.6 TRANSMISSION ANALYSIS

Template language: "Were transmission cost adders and integration costs properly assessed and applied to bids?"

For offers for new projects or projects proposing to increase the size of existing facilities, SDG&E's model calculated costs for transmission network upgrades or additions, using the information provided through the TRCRs or a CAISO-approved, completed System Impact Study. PA identified clusters for projects whose bids did not contain that information. Projects outside of the California ISO were expected to have internalized the cost of transmission to the ISO, as well as the cost of required transmission upgrades outside the ISO, into their bid price; they could still be assigned additional upgrade costs within California based on the TRCRs.

5.7 ADDITIONAL ISSUES

Template language: “Describe any additional criteria or analysis used in creating its short list (e.g. seller concentration). Were the additional criteria included in the solicitation materials?”

5.7.1 Affiliate bids and UOG ownership proposals

The treatment of affiliate bids has been a focus of PA throughout its tenure as Independent Evaluator for SDG&E. Although the Energy Division’s template does not specifically call for discussion of the handling of affiliate bids and UOG ownership proposals, the CPUC and FERC have both expressed concern about the fair treatment of non-affiliate bids. They required particular attention in past RFOs because SDG&E was conducting the evaluation itself, rather than having the IE do so. In this case, since PA conducted the evaluation, no special “masking” was required as in past RFOs.

SDG&E provided three alternative forms for bids: PPA, PPA with buyout option, and turnkey. The latter two are utility ownership forms. Several bidders submitted Alternative II (PPA with buyout) bids. In all cases these were additional options to Alternative I bids but the buyouts did not provide identifiable value. Several bidders submitted Alternative III (turnkey) bids, which were evaluated using a variant of a “revenue requirements” model and treating the revenue requirement to finance the purchase similarly to an annual PPA payment.

5.7.2 Viability

Developer and project viability have become a key concern in the Renewable RFO, because of the delays and contract failures that have affected several projects. The CPUC devoted special attention to viability in 2009, requiring “that each IOU include a project viability methodology and calculator in its amended 2009 Procurement Plan and solicitation package.”¹²

SDG&E requested bidders to complete a Project Viability Calculator (PVC) for each bid, rather than fill out the PVC for each bid. The PVC form was based on the format developed by the Energy Division. This was in order to avoid having the utility or IE create a PVC for every bid, since SDG&E did not know in advance how many bids would be received. In the event, 158 separate project proposals were received

SDG&E’s intent was that after the quantitative evaluation it would eliminate bids that, while scoring high, did not appear viable. One basis for doing so could have been the bidder-supplied PVCs; however, SDG&E and PA both expected bidders to take an optimistic view of viability and had therefore decided to rescore the PVCs from those bidders who scored highest in the LCBF ranking, beginning from the bidders’ own scoring. SDG&E and PA separately rescored sets of high-ranking bids. PA rescored a total of 52 of the 53 highest-ranked projects (based on LCBF ranking); the unscored project is already in operation and therefore 100% viable.

The original and revised scores are shown in Figure 1 in section 5.8.

¹² D. 09-06-018, p. 21.

5.7.3 Concentration risk

Before any bids were received, PA expressed to SDG&E its concern that much of the current base of RPS contracts is dependent on the completion of the Sunrise Power Link (Sunrise) transmission project. PA did not express such concern in 2009 and there was no particular evaluation of concentration risk. There were two reasons for this: (1) The Sunrise project has received its regulatory approval, removing a major risk factor and also relieving any concern about the impact of bid selection on that approval; (2) The CPUC specifically instructed SDG&E to encourage bidders who would deliver over Sunrise.

5.8 RESULTS ANALYSIS

*Template language:*¹³ 1. Please identify instances where the IE and the IOU disagreed in the LCBF evaluation process.

- a. Discuss any problems and solutions
 - b. Identify specific bids if appropriate
 - c. Does the IE agree that the IOU made reasonable and justifiable decisions to exclude, shortlist and or/ execute contracts with projects? If the IE did its own separate bid ranking and selection process and it differed from the IOU's results, then identify and describe differences.
 - d. What actions were taken by the IOU to rectify any deficiencies associated with rejected bids?
 - e. Other
2. Overall, was the overall bid evaluation fairly administered?"

One of the most important aspects of the Renewables RFO is the need determination. Under the Renewable Portfolio Standard, utilities seek to obtain at least 20% of their 2010 retail deliveries from renewable sources. SDG&E has further committed to obtain 33% of its 2020 retail deliveries from renewable sources. The primary goal of RPS procurement is total renewable volume. For an individual Renewable RFO, this translates to a "need" target.

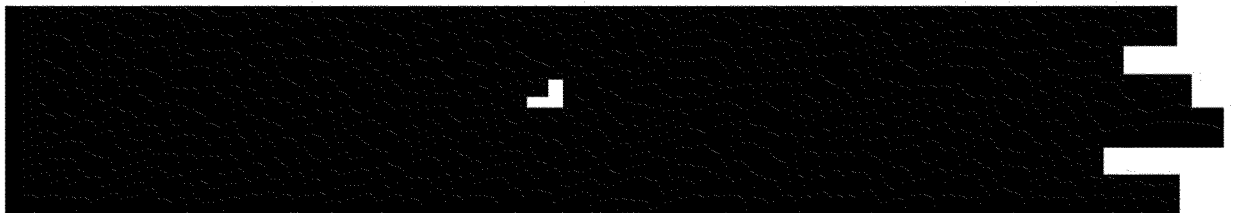

Therefore SDG&E reasoned it had no need except if it had underestimated contract failure probabilities.

SDG&E took a "largest hazard" approach, and analyzed the largest hazard in two ways: (a) the largest individual expected delivery volume; (b) the total expected delivery from contracts

¹³ Ibid., p. 11.

with viability scores below 75. In both cases the volume was about 1600 GWh, so SDG&E determined its need for this RFO was 1600 GWh per annum. Since those projects (the largest individual volume, and the contracts with viability scores below 75) were all in the SPL region, and since SDG&E has committed to replace SPL-region contracts with other SPL-region contracts, SDG&E said it would shortlist bids in the SPL region. PA concurs that all these decisions are reasonable.



SDG&E generally shortlisted bids in order of LCBF ranking, but in two cases chose not to shortlist bids due to low viability. The viability scores are illustrated in Figure 1. The two rejected bids are indicated by red X's. In one case the bidder had not provided a Project Viability Calculator; in the other, PA and SDG&E agreed that the bidder's self-score was overly optimistic.

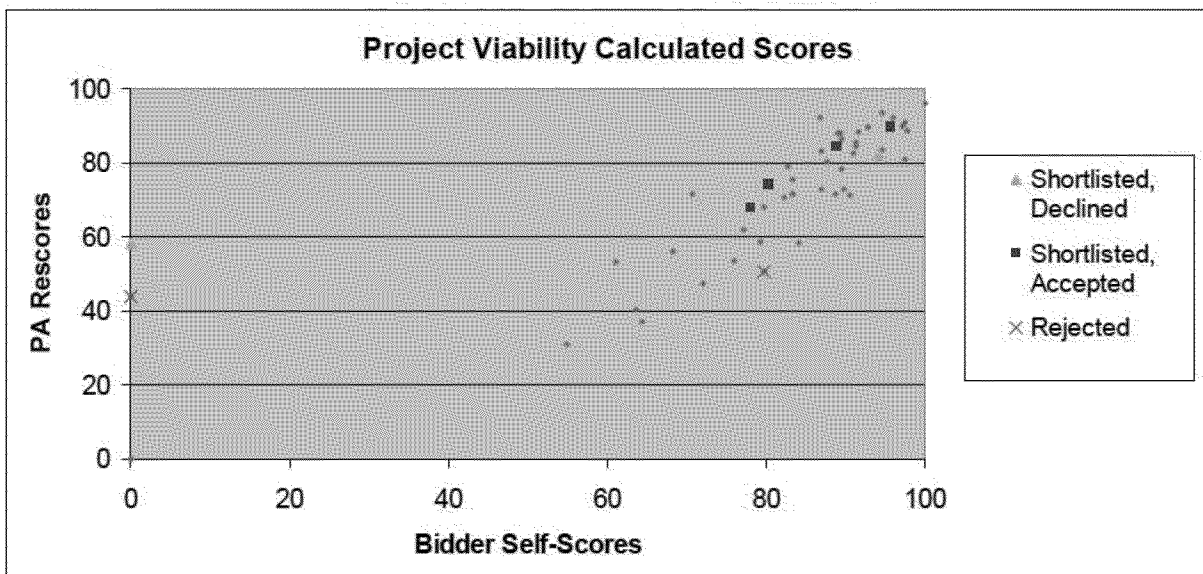

Figure 1 - Project Viability Scores

[REDACTED]

In PA's opinion, SDG&E conducted the RFO in fair and equitable manner. There were areas in which PA and SDG&E disagreed, as has been noted, but in each case PA believes that these were issues on which reasonable parties could disagree and that SDG&E, as the party at risk to meet its RPS objective, should have the prerogative to make those decisions.

One affiliate bid, Sempra Generation Energia Sierra Juarez - Jacume, is on the short list reported above. Of the SPL-area projects bid into this RFO, it was the second most highly ranked in the LCBF analysis. Although the project will be in Mexico, its generation tie will cross the border and interconnect in the Imperial Valley.

[REDACTED]

PA listened in on the first negotiation session between SDG&E and Sempra, at which SDG&E conveyed this condition. On that condition, PA believes it was appropriate to shortlist this bid.

SDG&E did not favor this affiliate bid, because PA conducted the LCBF evaluation, PA decided to evaluate the bid based [REDACTED]. Because this is an affiliate bid (and because it has the highest ranking price on the short list) PA intends to continue to follow closely the negotiations with Sempra. SDG&E has stated that they will invite the IE to all negotiation sessions with the affiliate (as opposed to just providing regular reports on the negotiations).

5.9 ADDITIONAL ISSUES

Template language: "Any other relevant information or observations:"

PA has nothing else to add to this chapter.

6. FAIRNESS OF PROJECT-SPECIFIC NEGOTIATIONS

In the spring of 2010, Tenaska Solar Ventures proposed two solar photovoltaic projects to SDG&E: Imperial Valley South, [REDACTED] and Imperial Valley West. As far as PA can tell, the Imperial Valley West project does not correspond to any bid from the 2009 RFO. PA has not reviewed the original bilateral proposal but was provided a "Project Overview" dated May 14 and characterized as "Attachment to Proposal of May 14, 2010". That Overview was basically a summary of land acquisition and permitting progress.

On April 19, 2013, SDG&E informed its Procurement Review Group that it was negotiating an amendment to the CSolar West contract "to increase the chances Tenaska will achieve financing the CPV technology and to benefit/protect our customers." Apparently the concentrating solar panels that Tenaska had intended to use for the project are not eligible for the "Section 1603" cash grant.

6.1 PRINCIPLES OF EVALUATION

Template language: "A. Identify principles used to evaluate the fairness of the negotiations."

The key questions are whether SDG&E showed favoritism to this or any other bidder, and whether SDG&E negotiated harder or less hard with them than with any other bidder. Note that in the context of negotiations, favoritism toward a bidder is not the same as favoritism toward a technology.

6.2 PROJECT-SPECIFIC NEGOTIATIONS

Template language: "Using the above principles (section V.A), please evaluate fairness of project-specific negotiations."

In general PA does not directly observe most contract negotiations, except for those with affiliates. PA follows negotiations through discussions with SDG&E, summaries of current proposals and SDG&E's reports to its Procurement Review Group. This is consistent with the original understanding of PA's role as IE, which was developed when PA and SDG&E negotiated their initial contract (with the participation of the PRG).

PA first became aware of Tenaska's bilateral proposal from SDG&E's report to its Procurement Review Group on August 20. This appears to have been the first mention to the PRG of the negotiation. Contract negotiations proceeded rather quickly, with agreement reached in mid-November on a general PPA form that could be used for each of the South and West projects. The Imperial Valley South PPA would specify conventional photovoltaic technology but the Imperial Valley West PPA would specify concentrating photovoltaic (CPV) technology, and would be contingent on the development of a CPV panel manufacturing plant in the San Diego area. If the panel plant were not operational by a specified date, Tenaska would have the option to convert the contract to a single-axis tracking PV technology at a lower capacity factor, and also a lower energy price.

The Imperial Valley South contract was executed in November, 2010. Execution of the Imperial Valley West contract was delayed by two issues:

[REDACTED]

The Phase I interconnection study produced an unexpectedly high cost which, if used to evaluate the project with SDG&E's LCBF model, could make it uncompetitive with the shortlist. Tenaska and SDG&E explored a number of ways to address this, but in the end the only modification to the November PPA form was to change the trigger for the interconnection condition precedent from [REDACTED]

PA did not participate in any of the negotiation meetings or conference calls, but did review drafts passed between SDG&E and Tenaska, as well as the "project status matrices" produced by SDG&E for its IEs. Based upon PA's reviews, the issues under discussion were generally those commonly discussed between SDG&E and its counterparties – limitations on developer liability for change of law, dates in the contracts, amounts of performance assurance, etc. PA does not believe that Tenaska was provided any particular advantage over other bidders.

[REDACTED] As with other counterparties, though, SDG&E insisted that Tenaska be obligated to deliver the contract capacity by the Commercial Operation Date. [REDACTED]

It is PA's opinion that the CSolar Imperial Valley West contract reflects fair negotiations.

PA did not observe any of the negotiations leading to the Second Amendment and did not see any drafts until the final version; however, nothing in the Amendment appears likely to have come from unfair negotiations.

6.3 TERMS AND CONDITIONS

Template language: "Identify the terms and conditions that underwent significant changes during the course of negotiations."

This contract provides SDG&E an option to purchase the project at the end of the contract term or if CSolar defaults on the contract. A great deal of the negotiation time and effort were devoted to specifying this option. The option is to be exercised at market value based on the way it is specified in the contract, and therefore should not affect PA's economic evaluation of the contract.

The Second Amendment represents a significant change to certain terms of the contract as revised by the First Amendment. Originally the contract specified that the plant would be constructed using concentrating solar panels, and provided a condition under which Tenaska could terminate the contract if the panel factory, which was expected to be built in San Diego County, did not get build or was unable to produce panels at a high enough rate. In that case Tenaska could also choose instead to convert the plant to a conventional design, at a slightly lower energy price and lower expected capacity factor. The First Amendment reworded this so it was not a condition precedent, and significantly increased the discount associated with the conversion.

[REDACTED] Furthermore, if the panel factory (which has been built and is successfully operating) has a “schedule impairment,” CSolar’s EPC contract may use an additional [REDACTED] of conventional panels, [REDACTED]

[REDACTED] If the plant is built with a mix of conventional and concentrating solar panels, the contractual capacity factor and price will be prorated accordingly. The pricing, if the plant is built entirely with one or the other type of solar panel, is the same as in the 2011 amended contract.

6.4 RELATION TO OTHER NEGOTIATIONS

Template language: “Was similar information/options made available to other bidders, e.g. if a bidder was told to reduce its price down to \$X, was the same information made available to others?”

PA does not believe that SDG&E provided CSolar with information of the type addressed here.

6.5 ADDITIONAL ISSUES

Template language: “Any other relevant information or observations.”

SDG&E originally filed this contract in Advice Letter 2257-E, dated May 27, 2011. [REDACTED]

[REDACTED]

On Oct. 3, 2011, SDG&E and CSolar executed the First Amendment to the contract. The contract’s price was reduced from [REDACTED] (before TOD-adjustment). Furthermore, the price if CSolar exercises its option to convert to conventional PV technology is decreased from [REDACTED] (again, before TOD-adjustment). In addition, the Amendment revises the contract to allow SDG&E to curtail the project for up to 5% of the annual Contract Quantity; however, SDG&E must still pay for the curtailed generation (less whatever CSolar is able to get for reselling it). There are a number of other

¹⁴ Tenaska is the parent developer and CSolar is a subsidiary.

¹⁵ SDG&E seemed to consider this a key point of contract law; PA is unable to judge if it is or not.

1.

technical changes, generally having to do with postponing various milestone dates, to account for the delay in CPUC approval. The analysis in this chapter is unaffected.

Although this contract was originally executed well before the 2011 RFO, it had not been bid into the 2009 RFO. This means that that contract was not shortlisted from the 2009 RFO and therefore CSolar had not demonstrated competitively that its pricing was at market.

[REDACTED] SDG&E did not show favoritism against this bidder, or treat them unfairly.

Amendment 2 provides that the Delivered Energy, which is what goes through the CAISO revenue meter(s), is broken down into concentrating and non-concentrating categories based on the ratios of the readings of additional "Concentrating Solar Units Energy Meters" and "Non-Concentrating Solar Units Energy Meters" to be installed between the inverters and the revenue meter(s) and positioned so that only concentrating panels are hooked up to "Concentrating" meters and only conventional panels to "Non-Concentrating" meters. The contract does not require every inverter to be connected to a concentrating or non-concentrating meter. In principle, the project route most of the energy conventional panels directly to the revenue meter, without passing through a "Non-Concentrating" meter. This would inflate the proportion of energy in the concentrating category.

There is no reason to believe that Tenaska would engage in such payment gaming, and SDG&E has assured PA that it would dispute any invoice where there was a significant difference between the total Delivered Energy and the sum of the readings of the "Concentrating Solar Units Energy Meters" and "Non-Concentrating Solar Units Energy Meters." Still, PA believes it would be reasonable for the CPUC to require some assurance, such as through a side letter from Tenaska, that every inverter will be connected through a "Concentrating Solar Units Energy Meter" or a "Non-Concentrating Solar Units Energy Meter."

7. PROJECT-SPECIFIC RECOMMENDATION

PA recommends that the CPUC approve the Second Amendment subject to the assurance referenced in Section 6.5. With either technology the contract is at a significant premium to the market, [REDACTED]

[REDACTED]. The amendment removes uncertainty around the project's viability and creates a significant likelihood that some conventional panels will be used. That will reduce the average price, and hence the cost to ratepayers. Furthermore, Amendment 2 pushes back the COD for a year so that it will not deliver power during Compliance Period 2 (in which SDG&E expects to have surplus renewable energy).

PA's original recommendation was that it was reasonable for the CPUC to approve the CSolar Imperial Valley West contract. When evaluated consistently with the 2009 RFO (using TRCR information to estimate transmission upgrade costs) it was competitive with the shortlisted projects from the 2009 RFO. If we estimate upgrade costs at [REDACTED] then SDG&E's LCBF model would have indicated that the conventional configuration (the conversion option) was comparable or slightly inferior to the shortlisted projects, and the CPV configuration was [REDACTED] more expensive than the 2009 shortlist. However, PA questioned the appropriateness of using the high upgrade cost estimates that the CAISO has produced lately for evaluating contracts if they were not used for the original shortlist. Furthermore, the CPV configuration may have additional benefits, related to facilitating local economic development, which PA was unable to quantify; we cannot exclude the possibility that those benefits exceed [REDACTED]

The revised pricing makes the contracts more desirable relative to the 2009 shortlist. However, that revision is accompanied by (and reacts to) a general decline in bid prices for renewable generation as represented by the pricing in the 2011 RFO. While PA is somewhat skeptical that solar panels will be available at the prices developers expect when they actually get around to building their plants, those bids represent the best currently available market indicator.

Relative to the 2011 RPS RFO, even the revised pricing for the CSolar Imperial Valley West contract with the CPV configuration is at a premium of [REDACTED] to the market. SDG&E did not actually evaluate and shortlist projects delivering in Compliance Period 2 like this one, but the pricing of the "conversion option" appears to be close to market (and is similar to the pricing of comparable projects offering Compliance Period 1 delivery that were shortlisted in the 2011 RFO). With the proposed concentrating photovoltaic technology, the project is more expensive. If the CPUC believes that the value to the San Diego economy of a new panel manufacturing facility, plus the value of advancing CPV technology, justify that price differential then it should approve the contracts.

7.1 EVALUATION

Template language: "A. Provide narrative for each category and describe the project's ranking relative to: 1) other bids from the solicitation and 2) from an overall market perspective:

1. *Contract Price, including transmission cost adders*

7. Project-specific recommendation

2. *Portfolio Fit*
3. *Project Viability*
 - a. *Project Viability Calculator score*
 - b. *IOU-specific project viability measures*
 - c. *Other (credit and collateral, developer's project development portfolio, other site-related matters, etc.)*
4. *Any other relevant factors."*

7.1.1 Original pricing as submitted with AL 2270-E

PA reviewed the CSolar West contract using the same evaluation model that had been used for the 2009 Renewables RFO. The contract capacity will be between 96 and 150 MW. For the sake of evaluation, PA assumed a contract capacity of 120 MW.

PA used the following assumptions and parameters:

- [REDACTED] price before TOD weighting, no escalation
- Commercial Online Date of December 31, 2015, which is the "Guaranteed Commercial Online Date" in the contract; 25-year term
- 120 MW capacity, [REDACTED] capacity factor, production profile as supplied by Tenaska
- Credit for system but not local resource adequacy
- Congestion cost of [REDACTED]/MWh
- [REDACTED] annual degradation
- Transmission upgrade cost based on TRCR

This is the "base case" analysis. PA also evaluated the project at a transmission upgrade cost of [REDACTED] and at a 150 MW capacity, \$ [REDACTED] upgrade cost. Furthermore, PA evaluated the plant Tenaska would construct if the panel manufacturing facility were not built and Tenaska exercised its conversion option, namely a 120 MW conventional photovoltaic plant with a [REDACTED] capacity factor and online date of June 1, 2016; and PA evaluated this alternative under two similar high upgrade cost cases:

Table 1. Ranking prices -- 2009 RFO model

<i>Technology</i>	<i>Upgrade estimate</i>	<i>Capacity</i>	<i>Ranking price</i>
CPV	TRCR	120 MW	[REDACTED]
CPV	[REDACTED]	120 MW	[REDACTED]
CPV	[REDACTED]	150 MW	[REDACTED]
Conventional PV	TRCR	120 MW	[REDACTED]
Conventional PV	[REDACTED]	120 MW	[REDACTED]
Conventional PV	[REDACTED]	150 MW	[REDACTED]

The last two projects on the original RFO shortlist were Energía Sierra Juárez, with a ranking price of [REDACTED], and [REDACTED] with a ranking price of [REDACTED]. The next, non-shortlisted bid, [REDACTED] had a ranking price of [REDACTED].

The next two projects were a turnkey project whose ranking price was [REDACTED], and a photovoltaic project at [REDACTED].

We have the following observations about the economics of the CSolar Imperial Valley West contract:

- When evaluated using a transmission cost estimate based on the TRCR, the contract compares favorably with the 2009 shortlist, both in the CPV and conventional configurations. That is the only true “apples to apples” comparison, since the ranking prices of the shortlisted projects were based on TRCR estimates.
- In the conventional PV configuration, even at the maximum [REDACTED] upgrade cost, if the plant is built to its maximum 150 MW its ranking price is better than every project that was not shortlisted.
- In the conventional PV configuration, at the maximum [REDACTED] upgrade cost and at 120 MW capacity, the plant’s value would be comparable to the best ranking prices among those plants that were not shortlisted or contracted.
- In the CPV configuration, at the maximum [REDACTED] upgrade cost, the plant is [REDACTED] MWh “out of the money”; however, there may be additional local economic benefits from the CPV manufacturing facility that would be justified by this project.

7.1.2 Revised pricing (Amendment 1)

Because the revised pricing is more than [REDACTED] lower than the original, the contract would score about [REDACTED] better under the 2009 LCBF model with the revised pricing than with the original pricing. The contracts would surely be economic in that case.

Realistically, though, Tenaska was asked to refresh its pricing because of new information reflected in other bids, and in particular in bids to the 2011 RFO. Therefore, both PA and

SDG&E evaluated the contract using the LCBF model for the 2011 RFO. PA evaluated the contract in two ways, based on TRCR upgrade cost estimates and using the negotiated limits.¹⁶ The TRCR estimates are the only uniform set of estimates for all bids, that is, they come from the only estimation method that can be and has been applied to all bids in the RFO. CAISO cost estimates associated with recent studies have been questionable, because of the underlying assumption that all projects already on the queue will be built before a study group.

The following table gives the bid ranking prices for the revised bids, using the 2011 RFO model. The reader will note that these ranking prices are much lower than the ranking prices for the original price from the 2009 model, and the ranking prices using conventional PV are even negative; the reason is that the 2009 model was based on bid prices while the 2011 model is based on only the “above market” part of bid prices (price minus TOD-adjusted MPR):

Table 2. Ranking prices -- 2011 RFO model

<i>Technology</i>	<i>Upgrade estimate</i>	<i>Capacity</i>	<i>Ranking price</i>
CPV	TRCR	120 MW	[REDACTED]
CPV	[REDACTED]	120 MW	[REDACTED]
CPV	[REDACTED]	150 MW	[REDACTED]
Conventional PV	TRCR	120 MW	[REDACTED]
Conventional PV	[REDACTED]	120 MW	[REDACTED]
Conventional PV	[REDACTED]	150 MW	[REDACTED]

These ranking prices appear quite competitive with the 2011 shortlist. But the reason that these prices are so competitive is that they do not deliver until 2014. Because they have no Compliance Period 1 deliveries, they have no “Short Term / Long Term” (STLT) adder, which was used to inflate the ranking prices of Compliance Period 1 bids.

In the 2011 RFO, SDG&E divided bids into three categories: those beginning delivery in Compliance Period 1 (2011-2013), those beginning delivery in Compliance Period 2 (2014-2016) and those beginning delivery in Compliance Period 3. SDG&E prioritized its immediate need, because it already had a backlog of signed contracts delivering in Compliance Period 2 (including this one, which had not yet been approved). After short-listing enough contracts delivering in Compliance Period 1 to meet RPS need through 2013, SDG&E would then seek to shortlist enough Compliance Period 2 bids to meet its post-2014 need. There were a large number of Compliance Period 2 bids with lower ranking prices than this CSolar bid [REDACTED]

¹⁶ According to the SDG&E TRCR, up to 125 MW could be connected at the Imperial Valley substation with no upgrade costs.

The analysis in the previous paragraph indicates that, with the CPV configuration, this contract's ranking price is at about a [REDACTED] premium. Considering the price before TOD adjustment, the premium is more like [REDACTED] (the levelized TOD-adjusted price is about [REDACTED] the contract price). On the other hand, the ranking price of the "conversion option" (Imperial Valley West with conventional PV technology) seems close to what would have been a market price for Compliance Period 2 bids. That is not a surprising result; it does indicate that it is the CPV technology rather than the specific project that is responsible for the pricing premium.

7.1.3 Amendment 2

Amendment 2 could be considered as a repricing of the contract insofar as it enabled the average price to be at an intermediate point between [REDACTED]. Amendment 2 also changed the guaranteed COD to Dec. 31, 2016 regardless of configuration. The evaluation of the project is also affected by the fact that CAISO completed its "Re-Study of C1C2 Projects Phase II" and provided an interconnection cost estimate of [REDACTED]^{6A}

There is no guarantee that, in the absence of Amendment 2, the contract will be terminated. The appropriate standard to apply in evaluating the Amendment is whether it improves the economics of the contract, not whether the amended contract would have been accepted in a more recent RFO. If the Amendment improves the economics, but would not have been accepted, then the current contract is worse and should still be amended. Still, CPUC Resolution E-4199, referenced in Chapter 2.1,^{16B} although it was primarily aimed at amendments that increased contract prices, requires us to compare the amended contract with the most recent MPR or, in PA's interpretation, the market as represented by recent RPS RFOs.

PA re-evaluated the 100% concentrating and 100% conventional options using the revised GCOD and interconnection cost estimate. The results of the 2011 evaluation model are given in Table 3.

Table 3. Ranking prices for Amendment 2 -- 2011 RFO model

<i>Technology</i>	<i>Capacity</i>	<i>Ranking price</i>
CPV	120 MW	[REDACTED]
CPV	150 MW	[REDACTED]
Conventional PV	120 MW	[REDACTED]
Conventional PV	150 MW	[REDACTED]

^{16A} California ISO, "Re-Study of C1C2 Projects Phase II Appendix A – C608 Individual Project Report", June 4, 2012, provided by Tenaska to SDG&E.

^{16B} See note 6B.

The differences between the 120 MW and 150 MW configurations are small, because those differences are based on the amount of energy over which the upgrade estimate is allocated, and the more recent upgrade estimate is [REDACTED]. No projects were shortlisted in 2011 with GCODs after 2013, but as noted in 7.1.2, had any such been shortlisted their ranking prices would have been [REDACTED]. Therefore this project would still be at a premium to market of [REDACTED] using concentrating PV, and probably [REDACTED] using conventional PV.

An additional RPS RFO was recently completed. [REDACTED] The associated advice letter (and Independent Evaluator report) is to be filed by June 7. PA evaluated the 100% concentrating and 100% conventional options using the 2013 evaluation model (but assuming the project would be paid using the old TOD factors, as in the contract). Results are given in Table 4.

Table 4. Ranking prices for Amendment 2 -- 2013 RFO model

<i>Technology</i>	<i>Capacity</i>	<i>Net market value</i>
CPV	120 MW	[REDACTED]
CPV	150 MW	[REDACTED]
Conventional PV	120 MW	[REDACTED]
Conventional PV	150 MW	[REDACTED]

The “Net market value” metric of the 2013 model is similar to the “Ranking price” metric of the 2011 model, but has the opposite sign. [REDACTED] Therefore this project appears to be well out of market.

7.1.4 Need

In the review of the Imperial Valley South contract PA noted that when SDG&E reported its 2009 RPS shortlist, it stated that “as of October 2009, SDG&E’s calculated need, based on signed contracts [REDACTED]¹⁷ but that SDG&E was still adding contracts “to bring in projects located within the IV area in support of Commission goals and with high viability scores in order to provide cover for delayed contracts.” Since that time it has become clearer that SDG&E has additional renewable need; furthermore under SBX1-2 the RPS target will increase to 33%. Therefore in its initial report PA considered it to be appropriate for SDG&E to sign additional renewable contracts, such as CSolar Imperial Valley West.

¹⁷ San Diego Gas & Electric Co., “LCBF Report: SDG&E Written Description of RPS Bid Evaluation and Selection Process and Criteria”, *2009 RPS Shortlist Report (Public Version)*, submitted Dec. 5, 2009 and distributed to service lists for R.06-02-012 and R.08-08-009, p. 8.

Prior to the 2011 RFO, SDG&E estimated its compliance period 2 RPS need (“probability weighted contingent need”) [REDACTED]

[REDACTED] That estimate was based SDG&E’s expectations of contract performance, which included zero deliveries from CSolar West in CP2. This means that the CSolar West contract is not needed before CP3, so it is reasonable to push back the GCOD.

7.1.5 Project Viability Calculator

PA computed Project Viability Calculator scores for the CSolar Imperial Valley West project both with concentrating PV technology (dependent on new manufacturing capacity) and conventional PV technology. Because the contract allows the conventional technology as a “fallback” it is appropriate to use the higher viability score associated with that technology as the score for this contract. PA arrived at a score of [REDACTED] depending on the interpretation of the guidelines for the Resource Quality attribute.

The scores were based on PA’s scoring for the CSolar Imperial Valley South project, and the comments in that Independent Evaluator report apply here. In addition:

- Because of the later Guaranteed COD, [REDACTED]
- [REDACTED]

¹⁸ J. Jacobs, memorandum entitled “Report of the Independent Evaluator on SDG&E’S Compliance Period 2 bundled renewable energy sale to Exelon Generation, Pilot Power and Noble Americas”, May 13, 2013, filed with SDG&E’s Advice Letter 2483-E, May 29, 2013.

Project Scoring		range 0 - 10
weight		
25%	Company / Development Team	
4	Project Development Experience	
1	Ownership / O&M Experience	
	<i>Total Category</i>	
	<i>Weighted Criteria</i>	
	<i>Normalized Category</i>	
	Weighted Category	
35%	Technology	
4	Technical Feasibility	
2	Resource Quality	
3	Manufacturing Supply Chain	
	<i>Total Category</i>	
	<i>Weighted Criteria</i>	
	<i>Normalized Category</i>	
	Weighted Category	
40%	Development Milestones	
4	Site Confirmation	
4	Financing Status	
4	Permitting Status	
3		
3	Interconnection Progress	
	Transmission Requirements	
	Reasonableness of COD	
	<i>Total Category</i>	
	<i>Weighted Criteria</i>	
	<i>Normalized Category</i>	
	Weighted Category	
Total Weighted Score		

7.2 RECOMMENDATION

Template language: “Do you agree with the IOU that the contract merits CPUC approval? Explain the merits of the contract based on bid evaluation, contract negotiations, final price, and viability.”

7.2.1 Original recommendation

It was reasonable for the CPUC to approve the CSolar Imperial Valley West contract based on the 2009 RFO. Based on an “apples-to-apples” comparison, it is comparable or superior to the shortlisted projects from the 2009 shortlist. If the transmission upgrade cost reaches its

contractual maximum, the CPV configuration would appear more expensive than the shortlisted projects; however, (a) the shortlisted projects could have experienced similar cost increases and (b) the Commission may consider the economic development benefit of the CPV manufacturing facility to be worth the additional cost.

7.2.2 Recommendation relative to the revised contracts

The standard of value for PA's original recommendation was the pricing of contracts that were shortlisted in the 2009 RPS RFO. PA has used this kind of standard consistently in valuing bilateral contracts, reasoning that an RFO represents the most reliable available market intelligence. By that standard the price reduction on these contracts has made them more desirable, and PA would make an even stronger positive recommendation than before. The need consideration above was really only for the purpose of making sure there was sufficient need for these contracts to be useful (whether or not they were the best way to fill that need).

There has been a significant time lag between RFOs. It is reasonable to consider that the 2009 RFO no longer provides a standard, now that the 2011 RFO has concluded – even though this contract was executed and submitted for approval prior to the 2011 RFO. If they had come through an RFO one might consider that they have a prior claim of reasonableness on that basis; but they were submitted bilaterally over a year before the 2010 RFO.

Prior to the 2011 RFO, there was no good source of market information for renewable generation contracts in San Diego and Imperial Counties; now we have the 2011 bids and results available, and at least anecdotal evidence that the Commission considers them a reasonable market standard for bilateral contracts. Under that standard, the CSolar Imperial Valley West contract, as a CPV plant, is almost certainly priced at a premium to the market. SDG&E did not actually shortlist Compliance Period 2 bids, or screen out non-viable or non-compliant bids, but there are enough bids relative to the total Compliance Period 2 need that the shortlist cutoff would have been well below the price of this contract (with CPV technology).

As noted above, the conversion option's ranking price is probably close to where the shortlist cutoff probably would have been.

The fact that the project seems much more competitive relative to the 2009 RFO indicates that CPV pricing has not declined as much as conventional PV pricing, perhaps because there are fewer suppliers or because it is a more complex and valuable product.

with the Soitec contracts, there are three possible justifications for approving this contract despite the higher cost of CPV:

1. Because it was submitted before the 2010 RFO and qualified under the standard current at the time
2. To support the development of new renewable technology
3. Because of the "economic development" value of the new factory (which may actually have increased as the economy has failed to recover).

The first reason is probably not sufficient. While PA supports the development of new technology in general, the value of that technology (as well as the economic development

value of supporting the panel manufacturing facility) cannot be precisely estimated. It is not an issue of market value but a judgment that the Commission would have to make.

7.2.3 Recommendation relative to Amendment 2

There is no guarantee that, in the absence of Amendment 2, the contract will be terminated. The appropriate standard to apply in evaluating the Amendment is whether it improves the economics of the contract, not whether the amended contract would have been accepted in a more recent RFO. If the Amendment improves the economics, but would not have been accepted, then the current contract is worse and should still be amended.

Using this standard PA recommends approval of Amendment 2. The Amendment delays the commercial operation of the project making it more likely that SDG&E will need the renewable energy for compliance purposes. The Amendment also makes it likely that at least some of the project will be built with conventional PV panels rather than concentrating, which will reduce the cost to ratepayers. Finally, the Amendment provides the EPC contractor an option to use even more conventional panels if there is a schedule delay.



Finally, Section 7.2.2 provides three reasons why the CPUC might have chosen to approve the contract in 2011 (including the First but not the Second Amendment), including “support[ing] the development of new renewable technology.” The Commission endorsed this rationale in approving SDG&E’s Advice Letter, stating “[t]he amended PPA is reasonable because its market valuation is comparable to SDG&E’s 2011 RPS solicitation, other comparable contracts, and the project has added value due to the potential for long-term technology diversity [emphasis added].”¹⁹ The Second Amendment increases the certainty that the plant will be completed using at least some concentrating solar panels, supporting that new technology.

PA recommends that the CPUC approve the Second Amendment subject to the assurance referenced in Section 6.5.

7.3 ADDITIONAL ISSUES

Template language: “Any other relevant information or observations.”

PA has nothing else to add to this chapter.

¹⁹ California Public Utilities Commission, Resolution E-4446, December 15, 2011, p. 11.