



Procedure for the Resolution of Unknown Pipeline Features (PRUPF)

Summary

This procedure provides instructions to select specifications for gas pipeline features (pipe and other pressure-containing components) in circumstances where specifications are unknown or uncertain.

This version contains information developed through January 2013. This includes a considerable amount of empirical data that has resulted in more conservative specification suggestions than those found in vintage gas standards. Some specific technical studies have not yet been completed and the general collection and analysis of empirical data to identify instances where this document should be more conservative have not yet been completed. These will likely result in revisions to technical content in this document.

NOTE

User input is critical to
continued development.
User input is to be provided
to the owner of this
document

Level of Use: Informational use for transmission pipeline systems and stations, though piping in major stations is often specialty equipment beyond the scope of this document.

Target Audience

Engineers engaged in MAOP validation including the building and quality control of pipeline features lists.

Engineers engaged in the assessment of unknown specifications in the context of:

- Integrity management
- Risk assessment
- Regulatory compliance
- Hydrotesting
- Pipeline engineering
- Gas standards development

Safety

SERIOUS bodily injury can occur when working in the field.



Procedure for the Resolution of Unknown Pipeline Features (PRUPF)

Do the following to protect yourself from the risk of injury:

- 1.1 Comply with Company and equipment manufacturer safety instructions when operating machinery.
- 1.2 Abide by chemical manufacturer safety rules when working with chemicals.
- 1.3 Wear Company approved personal protective equipment at all times.
- 1.4 Pay attention to your surroundings and be aware of:
 - Open or unstable trenches
 - Trips and falls
 - Falling objects
 - Traffic hazards
 - Dangerous animals and poisonous vegetation
- 1.5 See SAFE-1001S, "Safety and Health Program Standard" for more detailed instructions.

Before You Start

This procedure is the reference document preferred over individual vintage standards because it contains the most updated and accurate collection of facts—taken from empirical data and the appendices of the Procedure for the Resolution of Unknown Pipeline Features Reference Manual (PRUPF-RM). Familiarity with this PRUPF-RM is critical for subject matter experts (SME) who may be involved in more complex resolution issues that arise during the application of PRUPF.

Understanding the following information is critical in correctly performing the procedures described in this document:

- 1.1 Typically, pipe or fittings purchased for a single job are in a single purchase specification, so in cases where it is judged to be reasonable to assume that a single pipe or fittings specification is involved, apply field investigation results to all pipe or fittings within a job.
 1. Use the evidence available to determine the number of samples to be investigated.
 2. Obtain SME review and concurrence with the number of samples and its applicability throughout the pipeline under investigation.



Procedure for the Resolution of Unknown Pipeline Features (PRUPF)

3. IF you encounter one of the following:
- Evidence suggests that multiple specifications may be involved (e.g., multiple purchase orders, multiple suppliers),
 - Significant inconsistencies exist between the counts of purchased and installed components,

THEN conduct further analysis to determine how broadly to apply assumptions or field investigation results.

- 1.2 Kiefner’s “Pipe Wall Thickness Transition Weld Details and MAOP”—published on 08/02/2011, recommends to calculate hoop stress by using fitting or pipe base WT value along with basic design formula (49 CFR Part 192.105, “Design Formula For Steel Pipe”). This is done without considering a WT reduction that may exist in association with beveling – sometimes performed for a girth weld between two unequal WT values.
- 1.3 Do not apply conservative assumptions found in this procedure to pipeline components purchased and installed by other operators. This is based on the lack of evidence to support that other operators adhered to Company’s standards and practices.

Table of Contents

Subsection	Title	Page
1	INTRODUCTION	4
2	PIPE IN SYSTEMS PURCHASED FROM OTHER OPERATORS	7
3	ADJUSTMENTS FOR UNKNOWN COMPANY PURCHASE DATE	8
4	UNKNOWN PIPE SPECIFICATIONS	10
5	UNKNOWN WELD FITTING SPECIFICATIONS.....	27
6	PIPELINE COMPONENTS	46
7	FIELD ASSESSMENT	53
8	PROCESS EVOLUTION.....	60
	Appendix A, Determination Of Minimum Recommended Smys Values For Pipe	68
	Appendix B, Commercially Available Pipe Wall Thickness Values	87
	Appendix C, Pipe Minimum Wall 085626 Between 08/29/1972 And 07/27/1990	91



Procedure for the Resolution of Unknown Pipeline Features (PRUPF)

Procedure Steps

1 INTRODUCTION

- 1.1 A completed Pipeline Features List (PFL) or construction drawings and job file documents may contain instances where information for some of the pipeline features is unknown.
- 1.2 Automation of PRUPF includes:
 1. Company's macro embedded Microsoft Excel template PFL worksheet, populates the PFL with suggested specifications based on this procedure.
 2. Company's PFL maximum allowable operating pressure (MAOP) calculator, "Gas Pipeline Pressure Limit Calculation Guide" uses specification values in the PFL to calculate pressure limits in Company's enhanced Geographic Information System (GIS) in accordance with this procedure.
- 1.3 This procedure:
 1. Supports PG&E (Company) compliance with California Public Utilities Commission (CPUC) San Bruno incident Resolution L-410 and Rulemaking (R.) 11-02-019 directive requiring Company to review "traceable, verifiable, and complete as-built drawings and pipeline system components and, based on the reliable pipeline specifications, calculate the maximum allowable operating pressure (MAOP)."
 2. Affects development of information for transmission pipeline segments during the MAOP validation process and is used in engineering analysis by Gas Engineering and Operations.
 3. Serves as a historical reference document designed to help determine or assume conservative specifications based on historical information that is known in instances where specifications are unknown.
 4. Is used for the following purposes:
 - a. Determining the minimum specification value for an unknown pipeline feature that is required for MAOP validation
 - b. Confirming that a pipe segment or fitting is commensurate with location class (49 CFR Part 192.111, "Design Factor for Steel Pipe")
 - c. Performing other engineering analysis for which assumptions are needed to resolve unknown specifications
 5. Is an element of the process for determining when unknown information may need investigation through field verifications, such as nondestructive testing for unknown pipeline features



Procedure for the Resolution of Unknown Pipeline Features (PRUPF)

- 1.4 See “Before You Start” Section, Note 1.1 when unknown feature specification information is acquired through a field verification process and these specifications are intended to be used to extrapolate specifications for other features.
- 1.5 See Section 7, “Field Assessment” when performing field investigations and tests.
- 1.6 For install dates beginning on 03/01/1940, choose specifications for unknown weld fittings (weld elbows, tees, caps, and reducers) that are suitable for the intended pressure at the time of installation. For more information, see:
 - Table 6, “Selecting WT and YS for Manufactured Bends (Elbows) and Weld Caps when both Specifications are Unknown (Use in Conjunction with Table 12)”
 - Table 7, “Selecting WT for Manufactured Bends (Elbows) and Weld Caps when YS is Known (Use in Conjunction with Table 12)”
 - Table 8, “Selecting YS for Manufactured Bends (Elbows) and Weld Caps when WT is Known”
- 1.7 For install dates beginning on 04/12/1963, choose specifications for all fittings, valves, and other piping components that are suitable for the intended pressure when installed.
- 1.8 Use industry and/or Company’s historical standards combined with empirical data from Company’s transmission pipeline system as acceptable references to identify unknown PFL information.
- 1.9 IF an alternative to the assumptions presented in this procedure is adopted,
THEN do the following:
 1. Document the variance—including its explanation, reason for choosing it, and technical rationale to support its legitimacy.
 2. Obtain approval for the variance from one of the following technical organizations:
 - a. MAOP Validation
 - b. Pipe Line Engineering
 - c. Transmission Integrity Management
 - d. Codes and Standards
 3. Retain all documentation in project file that is electronically uploaded to the Enterprise Content Management System.
 4. Provide a copy of the above outlined documentation to Codes and Standards for retaining in file associated with this procedure—to support continued assessment of possible changes needed to this procedure.



Procedure for the Resolution of Unknown Pipeline Features (PRUPF)

5. Use the new PODS/Intrepid GIS system to associate and link the documentation for this variance to the impacted gas transmission components. This documentation must meet the same standards of traceable described in TD-4125P-08, "MAOP Validation and Verification," Attachment 2, "Pipeline Records Quality Evaluation."
- 1.10 See Figure 1, "Pipe Process Overview" for a summary of processes for pipe presented in this procedure.
- 1.11 See Figure 2, "Weld Fitting Process Overview" for a summary of weld fittings processes presented in this document.

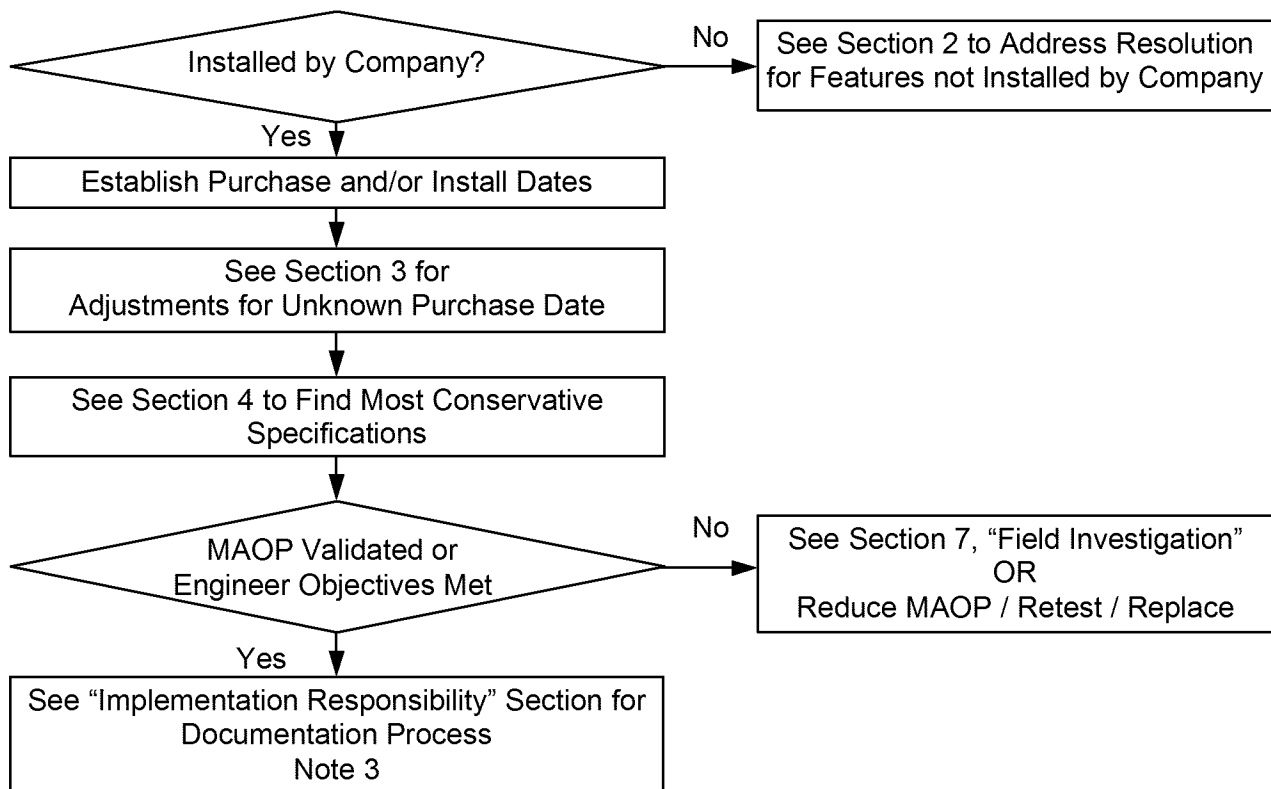

Figure 1. Pipe Process Overview



Procedure for the Resolution of Unknown Pipeline Features (PRUPF)

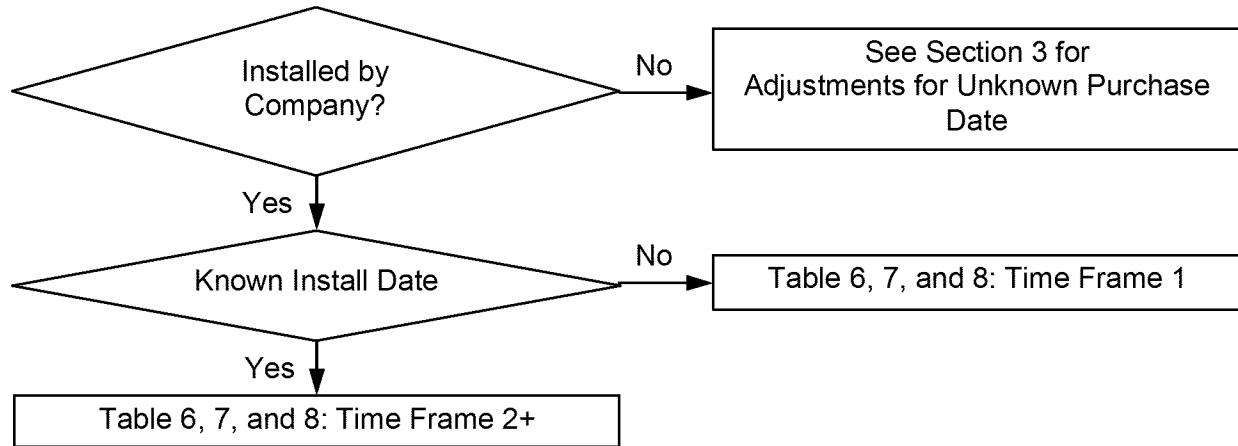

Figure 2. Weld Fitting Process Overview

2 PIPE IN SYSTEMS PURCHASED FROM OTHER OPERATORS

- 2.1 Do not apply conservative assumptions found in this procedure to pipeline components purchased and installed by other operators. This is based on the lack of evidence to support that other operators adhered to Company's standards and practices.
- 2.2 Perform an assessment of pipe specifications to meet MAOP as appropriate.
- 2.3 IF the combination of specified minimum yield strength (SMYS), wall thickness (WT), and joint efficiency (E) needed to meet MAOP are:
 1. Below reasonable minimums as judged by Company's SME review,

THEN it is reasonable to adopt low specifications that are the minimum needed to meet MAOP. For example, 0.050-inch WT and lap weld (LW) are determined to be sufficient for 6-inch pipe to meet MAOP because LW is the most conservative seam assumption possible in this instance, and wall this thin is well below reasonable minimums for gas pipe.
 2. Higher than reasonable industry minimums as judged by SME review,

THEN perform a field investigation as described in Section 7, "Field Assessment". See Appendix B, "Commercially Available Pipe Wall Thickness Values" for minimum WT values (use smallest WT value for diameter as issued) that can be combined with 24 kilopounds per square inch (kpsi) minimum yield strength (YS) to assess options.

Procedure for the Resolution of Unknown Pipeline Features (PRUPF)

2.4 See Figure 3, "Purchased Systems Process" for more information.

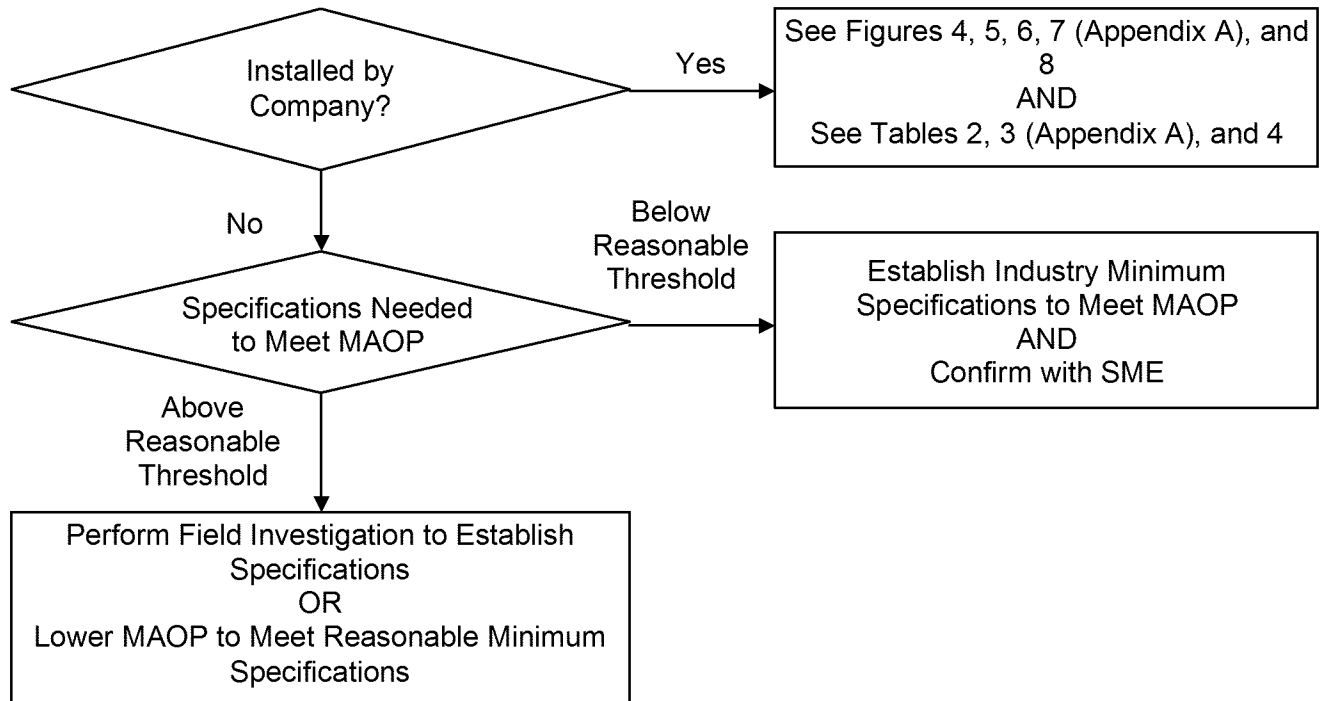

Figure 3. Purchased Systems Process

3 ADJUSTMENTS FOR UNKNOWN COMPANY PURCHASE DATE

3.1 IF purchase date for a feature installed by Company is unknown AND cannot be approximated,

THEN time periods during which the feature could have been purchased must be adjusted as described below.

NOTE

The ten-year purchase period described in this section does not affect all feature specifications. Adjustments are noted in tables throughout this procedure when applicable.



Procedure for the Resolution of Unknown Pipeline Features (PRUPF)

- 3.2 Known purchase date is typically established by reviewing documentation in project file, such as purchasing, transportation, or receipt documents. In several instances, a feature was purchased five, seven, or even eight years before installation took place. Based on this information, Company uses the most conservative specification associated with a ten-year purchase period ending on the installation date.

Example:

According to this assumption policy, 12-inch pipe installed on 01/01/1945 could have been purchased any time between 01/02/1935 and 01/01/1945—ten-year purchase period. The choices presented for this ten-year purchase period are LW, seamless (SMLS), or electric resistance weld (ERW)—see Table 2, “Most Conservative Assumptions for Unknown Pipe Seam”. Since LW is the more conservative choice because of its lower E, it is selected as the specification to adopt.

- 3.3 See Figure 4, “Purchase Date Adjustment Process” for an overview of adjustments for unknown Company purchase date.

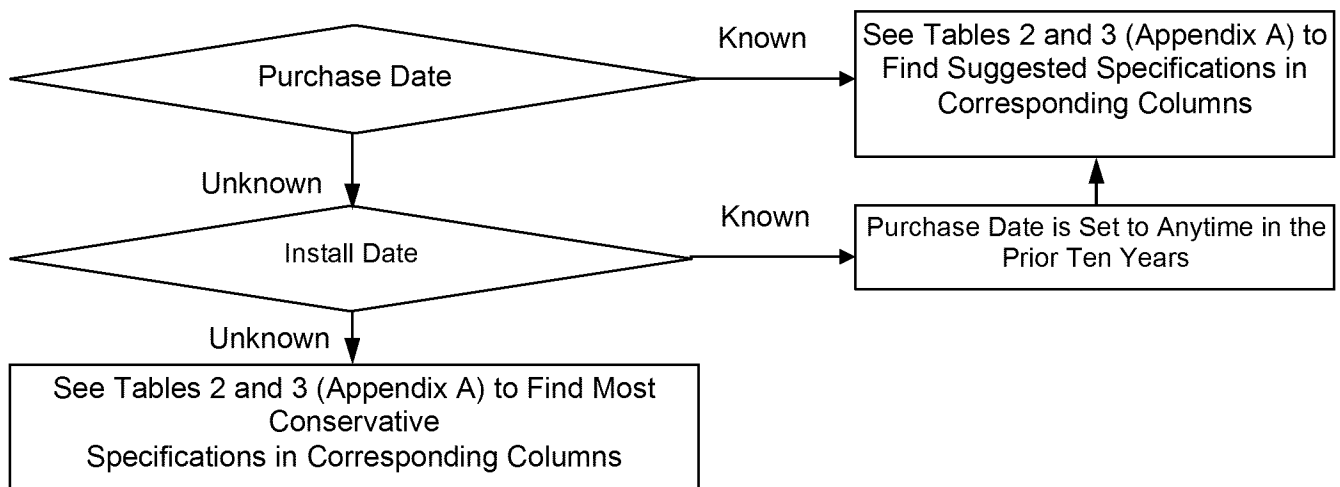

Figure 4. Purchase Date Adjustment Process



Procedure for the Resolution of Unknown Pipeline Features (PRUPF)

4 UNKNOWN PIPE SPECIFICATIONS

Unknown Pipe Specifications Overview:

- 4.1. General
- 4.2. Diameter
- 4.3. Determination of Seam Type and Joint Efficiency
- 4.4. Joint Efficiency Testing
- 4.5. Determination of Minimum Recommended SMYS Values for Pipe
- 4.6. Exceptions
- 4.7. SMYS Testing
- 4.8. Wall Thickness Determination
- 4.9. Wall Thickness Testing

Tables Overview:

- Table 1. Pipe Seam and Joint Efficiency Summary
- Table 2. Most Conservative Assumptions for Unknown Pipe Seam
- Table 3. Minimum Recommended SMYS Values for Pipe (see Appendix A)
- Table 4. Company-Specific Exceptions
- Table 5. Minimum Recommended Wall Thickness for Pipe



Procedure for the Resolution of Unknown Pipeline Features (PRUPF)

4.1 General

1. The process to find suggested specification starts by using engineering analysis as well as Company and industry historical information to determine the specification value for an unknown line pipe feature installed by Company.
2. Follow steps presented in Figure 5, "Find Suggested Specifications Process."
3. Proceed to:
 - Table 1, "Pipe Seam and Joint Efficiency Summary"
 - Table 2, "Most Conservative Assumptions for Unknown Pipe Seam"
 - Table 3, "Minimum Recommended SMYS Values for Pipe" (Appendix A)
 - Table 5, "Minimum Recommended Wall Thickness for Pipe"



Procedure for the Resolution of Unknown Pipeline Features (PRUPF)

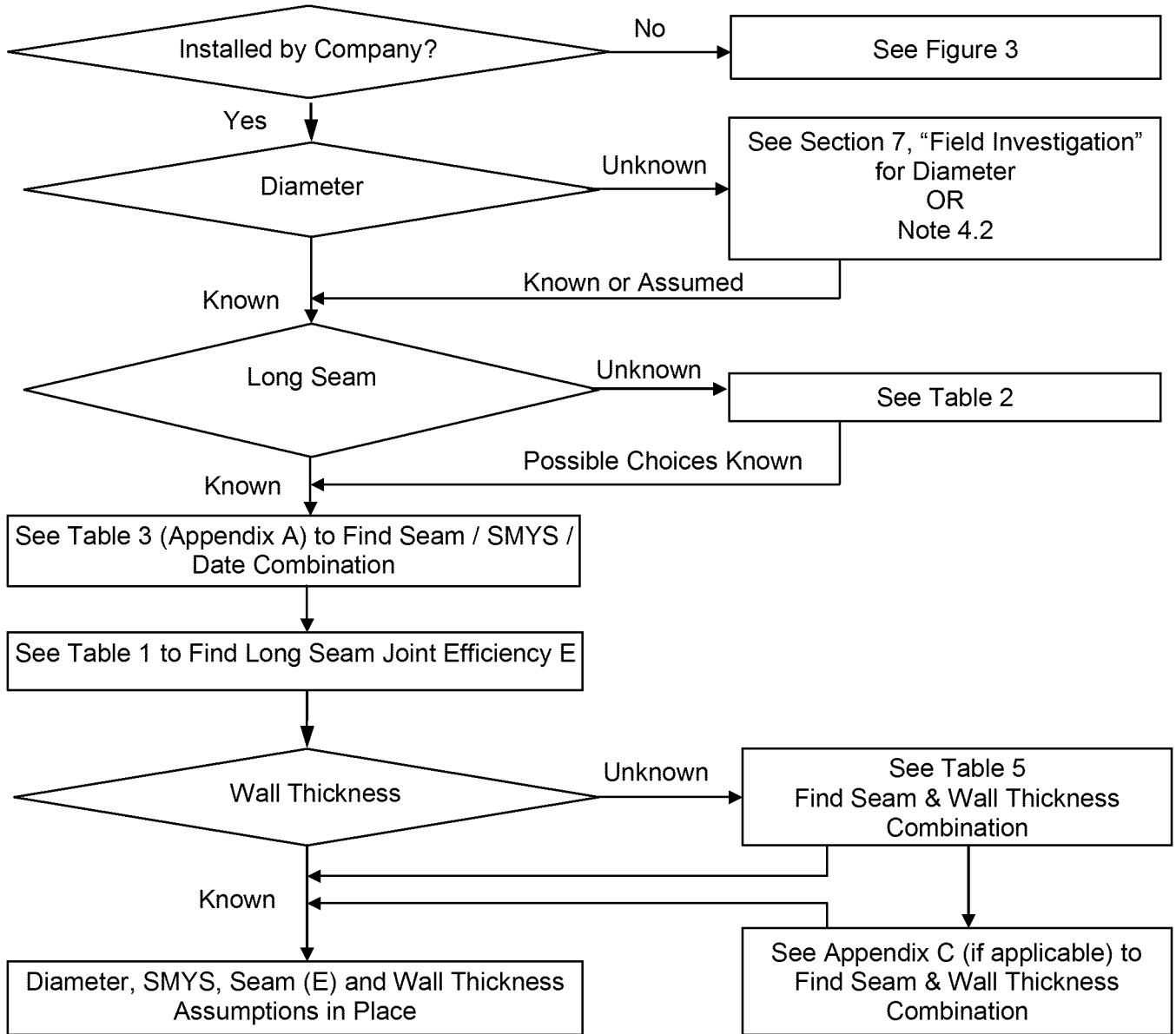

Figure 5. Find Suggested Specifications



Procedure for the Resolution of Unknown Pipeline Features (PRUPF)

4.2 Diameter

1. Diameter is a required first known fundamental attribute when employing this procedure to obtain suggested specifications for pipe or pipeline components.
2. IF the diameter is unknown,

THEN do one of the following:
 - a. Perform a field assessment to determine diameter. Field assessment consists of determining the number and locations to measure diameter of a pipe segment within the range of the original installation job. See Section 7, "Field Assessment" and "Before You Start" Section, Note 1.1.
 - b. Make conservative assumptions as described below.

4.3 Determination of Seam Type and Joint Efficiency

1. Use longitudinal seam type as the specification in Table 1 to determine joint efficiency factor.
2. Use Table 2 to determine pipe longitudinal seam type based on a known pipe diameter. Dates shown in table are purchase dates. Table 2 displays seam types for range of diameters and other relevant circumstances.
3. Employ the joint factor associated with known seam type in Table 1.
4. See Section 7, "Field Assessment" for more details.



Procedure for the Resolution of Unknown Pipeline Features (PRUPF)

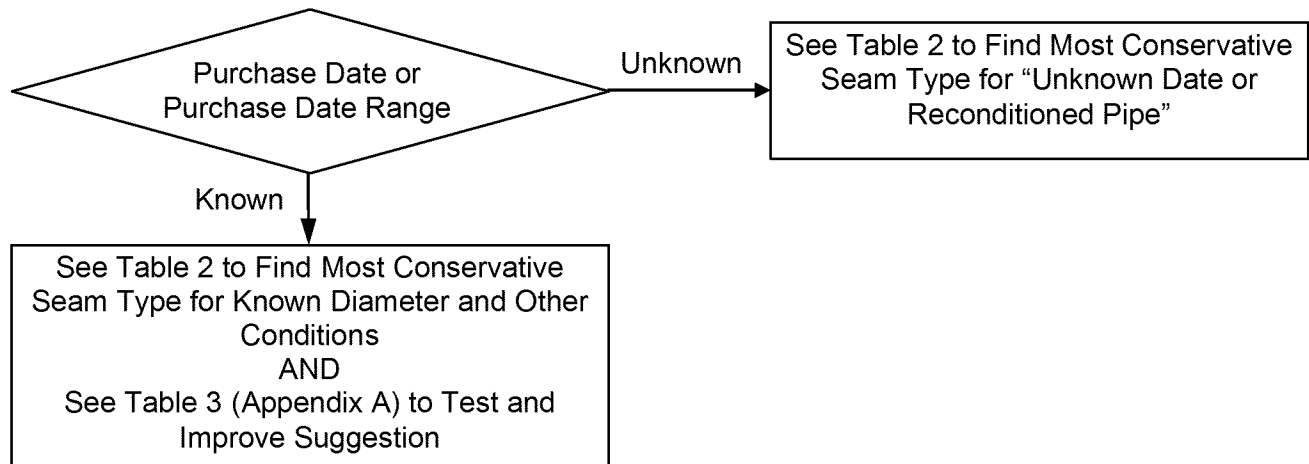

Figure 6. Determination of Most Conservative Assumptions for Unknown Pipe Seam Process

NOTE

It is possible that 1.0 joint efficiency (E) factors exist under special circumstances for single submerged arc welded (SSAW) and A.O. Smith (AOS) pipe. In situations where an E=0.8 factor does not meet MAOP, review circumstances with an SME to explore whether E=1.0 may be appropriate. Field investigations are required in most cases for AOS pipe to establish E=1.0. Manufacturing inspection documentation would likely be a requirement for SSAW pipe.

Procedure for the Resolution of Unknown Pipeline Features (PRUPF)

Table 1. Pipe Seam and Joint Efficiency Summary

Longitudinal Seam Type	Joint Efficiency Factor
Double submerged arc welded (DSAW)	1.0
Submerged arc weld long seam(SAWL) – an alternative term for DSAW	1.0
Seamless (SMLS)	1.0
Early electric resistance welded (ERW) (pre-1970 installation date) NOTE: While 1.0 as with modern high-frequency ERW, this classification of pipe is treated separately from modern ERW in the context of integrity management and has a different location Class 1 hydrostatic test pressure ratio for MAOP validation.	1.0
Modern ERW (1970 and newer) ERW high frequency weld (HFW)	1.0
Electric fusion weld (EFW). This term, found in Company's records, is associated with DSAW pipe manufactured by Consolidated Western and is not EFW weld type presented immediately below.	1.0
EFW - ASTM A134 and ASTM A139 fusion arc weld seams appear in ASME code	0.8
Lap welded (includes pre-1967 spiral weld)	0.8
Single submerged arc weld (SSAW)	0.8
A. O. Smith (AOS) flash weld + cap (prior to ~1942)	0.8
AOS SMAW	0.8
AOS modern flash weld (~1942 and later) must be confirmed with field inspection	1.0
AOS DSAW	1.0
Early spiral weld (SW) (1966 and earlier)	0.8
Modern SW (1967 and later)	1.0
Butt weld (BW) seam (all diameter less than or equal to 4.5-inch, NPS4—4.5-inch outside diameter (OD) or smaller)	0.6
Unknown four inches or less (NPS4—4.5-inch OD or smaller): Unknown with diameter less than or equal to four inches (if circumstances analyzed in Table 3 (Appendix A) show that it could be BW)	0.6
Unknown four inches or less (NPS4—4.5-inch OD or smaller): Unknown with diameter less than or equal to four inches (if circumstances analyzed in Table 3 (Appendix A) show that it could NOT be BW seam)	0.8



Procedure for the Resolution of Unknown Pipeline Features (PRUPF)

Longitudinal Seam Type	Joint Efficiency Factor
Unknown pipe size larger than NPS4 (or 4.5-inch) (lowest joint efficiency applicable, if circumstances analyzed in Table 3 (Appendix A) show that it could be 0.8)	0.8
Unknown pipe size larger than NPS4 (joint efficiency applicable if circumstances analyzed with Table 3 (Appendix A) show that it could NOT be 0.8)	1.0
Unknown greater than four - modern (based on Company’s historical procurement practices; seam designation based on purchase year and nominal pipe size). While no longer used in current assumption processes (starting with PFL V25), this seam type does appear in PFL’s in Q1 2013 and earlier.	1.0
Special 0.95 (associated with station piping—found sometimes in construction documents)	0.95
Special 0.9 (associated with station piping—found sometimes in construction documents)	0.9
Special 0.85 (associated with station piping—found sometimes in construction documents)	0.85

5. Use the following information to determine the most conservative assumptions for unknown pipe seam:
 - a. IF pipe is shown to be reconditioned or is believed to potentially be reconditioned—based on other information,

THEN such pipe would have been purchased by Company because the term “recondition” in Company’s records is only applied to pipe reconditioned by Company.
 - b. IF you believe reconditioned pipe was purchased from another operator,

THEN see “Before You Start” Section, Note 1.3.
 - c. For reconditioned pipe that was originally installed by Company and has an unknown purchase date, use specifications presented in the “Unknown Date or Reconditioned Pipe or Pipe Purchased from Prior Operator” column of Table 2.
 - d. In situations where pipe was known to have been, or is believed to potentially have been purchased in service from a third party pipeline operator, refer to Section 2, “Pipe in System Purchased from Other Operators.”



Procedure for the Resolution of Unknown Pipeline Features (PRUPF)

- e. While some wrought iron pipe has been found in Company system in the past, the circumstances were very specific to limited locations. Wrought iron remaining in service is known to be only in the San Jose Story Road Feeder. When working with unknown wrought iron pipe purchased from other operators, use 24 kpsi YS as specified by code (49 CFR Part 192 Appendix B, II. D., "Qualification of Pipe")
 - f. Company's experience and historical purchasing references show that 4.5-inch is the maximum size for BW pipe. Therefore, BW is limited to four inches nominal and below in Table 2.
 - g. *The History of Line Pipe Manufacturing in North America* indicates that 36 inches is the maximum size for LW pipe. However, since 24 inches is the maximum diameter found during Company's use of LW pipe prior to 1930, Table 2 contains LW in all sizes from above four inches up to 24 inches.
 - h. While Company has no record of 18-inch lap weld, because larger diameter lap weld pipe has been found in standards and/or in the field, 18-inch pipe purchased prior to 12/31/1930 should be reviewed with an SME for the possibility that $E = 0.8$.
 - i. While spiral welded (SW) pipe is not found in Company standards, Company has encountered this type of pipe in a small number of circumstances. SW pipe made since the beginning of 1967 is known as $E=1.0$, while pipe made prior to 1967 is assumed to be $E=0.8$.
 - j. Although Company's standards and historical records show that it began to purchase ERW pipe in 1941, instances of pre-1941 ERW have been found in the field. Therefore, ERW pipe is included in Table 2 and Table 3 (Appendix A) with suggestions for conservative assumptions going as far back as the early 1930s even though no Company standards addressing the 1930s time period have been found.
 - k. IF using Table 2 yields results inconsistent with SME expectations,

THEN use Table 3 (Appendix A) in conjunction with Table 2 to consider whether other appropriate specification assumptions exist instead of the base case conservative assumptions in Table 2 only.
6. Butt Weld Seam Pipe:
- a. IF the MAOP-R of piping system was greater than 400 pounds per square inch gauge (psig) at the time of installation AND installation occurred on or after 10/13/1964—when Company adopted a 400 psig limit for BW pipe,

THEN, the unknown pipe feature is not BW pipe—because the policy of this procedure allows the assumption that engineers adhered to this requirement.

Procedure for the Resolution of Unknown Pipeline Features (PRUPF)



Greater detail for some aspects of seam type is provided in Table 3 (Appendix A), so Table 2 should not be relied upon by itself.

7. Table 2 contains the following abbreviations:
- AOS: A.O. Smith
 - DSAW: Double submerged arc weld
 - ERW: Electric resistance weld
 - SMLS: Seamless
 - SSAW: Single submerged arc weld

Table 2. Most Conservative Assumptions for Unknown PipeSeam

Nominal Pipe Size (Inches)	Unknown Date or Reconditioned Pipe or Pipe Purchased from Prior Operator	Any or Unknown Date	Known Purchase Date	
			See Section 3 if Purchase Date is Unknown	
≤ 2	Butt Weld			
3	Butt Weld		≤ 02/12/1973	≥ 02/13/1973
			Butt Weld	SMLS or ERW
4	Butt Weld		≤ 10/26/1967	≥ 10/27/1967
			Butt Weld	SMLS or ERW
6	Lap Weld		≤ 12/31/1930	≥ 01/01/1931
			Lap Weld	SMLS or ERW
8	Lap Weld		≤ 12/31/1930	≥ 01/01/1931
			Lap Weld	SMLS or ERW
10	Lap Weld		≤ 12/31/1930	≥ 01/01/1931
			Lap Weld	SMLS or ERW

Procedure for the Resolution of Unknown Pipeline Features (PRUPF)

Nominal Pipe Size (Inches)	Unknown Date or Reconditioned Pipe or Pipe Purchased from Prior Operator	Any or Unknown Date	Known Purchase Date		
			See Section 3 if Purchase Date is Unknown		
12	Lap Weld		≤ 12/31/1927	01/01/1928 to 12/31/1930	≥ 01/01/1931
			Lap Weld	Lap Weld, AOS, or SSAW	SMLS or ERW
14	Lap Weld		≤ 12/31/1930	≥ 01/01/1931	
			Lap Weld	SMLS or ERW	
16	AOS or Lap Weld		≤ 12/31/1948	≥ 01/01/1949	
			AOS	SMLS or ERW	
18		SMLS, ERW, or DSAW ⁽¹⁾			
20-26	Lap Weld, SSAW, or AOS		≤ 12/31/1948	≥ 01/01/1949	
			SSAW or AOS	SMLS or DSAW	
30-42		DSAW			

Table note:

(1): See Note 4.3, Item 5i.

4.4 Joint Efficiency Testing

1. IF you encounter one of the following:

- Company prefers to use a seam type and corresponding joint efficiency (E) value that are different than those identified from the use of Table 1 and Table 2,
- Pipeline records and information presented in this section do not conclusively establish the most conservative longitudinal seam,

THEN conduct field investigation of longitudinal seam type. See:

- Section 7, "Field Assessment"



Procedure for the Resolution of Unknown Pipeline Features (PRUPF)

- “Before You Start” Section, Note 1.1.

Example:

IF using $E=0.8$ results in a failure to validate MAOP,

THEN conduct further assessment to explore whether $E=1.0$ pipe may possibly be installed, which may support field investigations that may reveal pipe to actually be $E=1.0$.

4.5 Determination of Minimum Recommended SMYS Values for Pipe

1. See Appendix A, “Determination of Minimum Recommended SMYS Values for Pipe.”

4.6 Exceptions

1. Table 4, “Company-Specific Exceptions” contains information that occurred only in one single instance. Therefore, these specifications are not adopted for unknown pipe. However, in situations where MAOP-R of unknown feature exceeds that of the exceptions, consideration should be given to whether the unknown feature might actually be one of these exceptions.
2. Table 4 contains the following abbreviations:
 - AOS: A. O. Smith
 - E: Efficiency (is also known as joint factor (JF))
 - LW: Lap Weld
 - MAOP-D: Maximum allowable operating pressure of design basis
 - SMLS: Seamless pipe
 - SMYS: Specified minimum yield strength
 - SSAW: Single submerged arc weld
 - SW: Spiral weld
 - WT: Wall thickness

Procedure for the Resolution of Unknown Pipeline Features (PRUPF)

Table 4. Company-Specific Exceptions

Diameter (Inches)	WT	SMYS	Seam	E	Purchase Date	Install Date	class 3 MAOP-D
4.5	0.196	28000	LW	0.8	1948	1948 to 1958	975
4.5	0.156	28000	SMLS	1	06/14/1962 to 10/12/1964	06/14/1962 to 10/11/1974	970
4.5	0.109	28000	SMLS	1	01/01/1930 to 12/31/1930	01/01/1930 to 12/30/1940	678
4.5	0.107	28000	SMLS	1	06/14/1962 to 10/12/1964	06/14/1962 to 10/11/1974	665
6.625	0.169	24000	SW	0.8	06/17/1948	06/17/1948 to 06/16/1958	489
8.625	0.203	24000	SW	0.8	12/21/1945	12/21/1945 to 12/20/1955	451
8.625	0.322	35000	LW	0.8	At or prior to 08/22/1932	At or prior to 08/21/1942	1045
12.75	0.203	33000	AOS	0.8	08/07/1941	08/07/1941 to 08/06/1951	420
16	0.281	42000	SSAW	0.8	01/01/1953 to 12/31/1954	01/01/1953 to 12/30/1964	590

4.7 SMYS Testing

1. Conduct a field investigation when SMYS prevents validation of MAOP:
 - As part of the field investigation, capture SMYS data for future use and to validate the assumption provided by PRUPF.



Procedure for the Resolution of Unknown Pipeline Features (PRUPF)

- IF an MAOP higher than that provided in PRUPF is desired,
THEN conduct destructive testing as specified in 49 CFR 192,
Appendix A.II.D.
2. Perform a field assessment to test SMYS of pipe segment in a single excavation at any location within the range of original installation job. See:
 - “Implementation Responsibility” Section, Note 5, “MAOP Validation Process”
 - Section 7, “Field Assessment”
 - “Before You Start” Section, Note 1.1

4.8 Wall Thickness Determination

1. The following steps use Company’s collection of minimum established values for pipe WT purchased over time to address the selection of appropriate specification assumption for pipe. See Figure 8, “Determination of Minimum Recommended Pipe Wall Thickness Process.”
2. Minimum assumed values:
 - Refer to Table 5 for minimum WT assumption based on purchase date.
 - WT for pipe purchased prior to 02/26/1942 is assumed to be the same as those found as of 02/26/1942.
3. When purchase date is unknown, but install date is known, see Section 3, “Adjustments for Unknown Company Purchase Date.”
4. Choose the most conservative value when multiple cells in Table 5 overlap with multiple values. This occurs when a ten year time frame encompasses multiple choices in Table 5.

4.9 Wall Thickness Testing

1. Conduct a field investigation to establish WT if Company prefers to use higher values than those in Table 5. For example, when Table 5 value results in an MAOP-D below MAOP-R, field investigation is needed to establish a higher WT sufficient to support MAOP-R.
2. Perform a field assessment to test WT of pipe segment in a single excavation at any location within the range of original installation job. See:
 - “Implementation Responsibility” Section, Note 5, “MAOP Validation Process”
 - Section 7, “Field Assessment”
 - “Before You Start” Section, Note 1.1

Procedure for the Resolution of Unknown Pipeline Features (PRUPF)

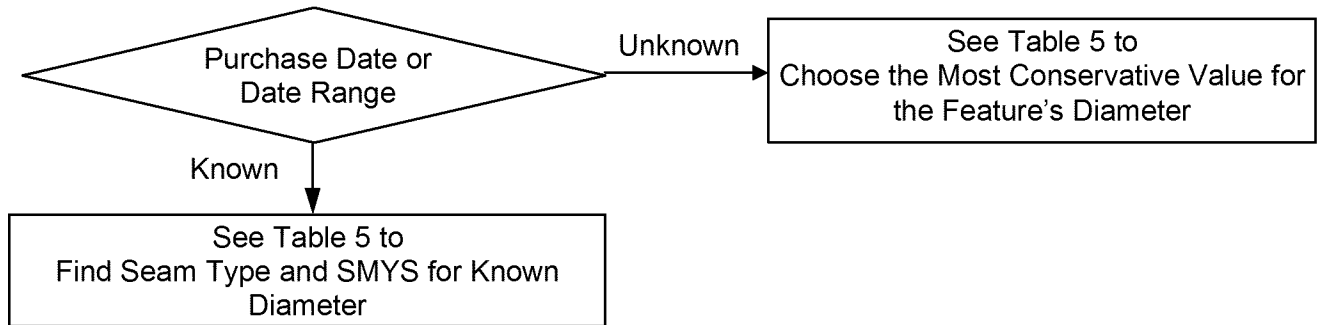

Figure 8. Determination of Minimum Recommended Pipe Wall Thickness Process

3. Table 5 contains the following abbreviations:

- BW: Butt weld
- ERW: Electric resistance weld
- SMLS: Seamless
- SW: Spiral weld
- WT: Wall thickness
- → : Use value in the cell to the right

Table 5. Minimum Recommended Wall Thickness for Pipe

Nominal Diameter (Inches)	Diameter (Inches)	Seam Type	PURCHASE DATE TIME FRAME					
			See Section 3 if Purchase Date is Unknown					
			At or Prior to 02/25/1942	02/26/1942 to 02/11/1951	02/12/1951 to 11/23/1959	11/24/1959 to 01/16/1969	01/17/1969 to 08/28/1972	As of 08/29/1972
			TYPICAL MINIMUM WALL THICKNESS (Inches)					
1/4	0.5	BW or Unknown	Unknown					
1/2	0.84	Not BW	→	0.109	0.109	0.109	0.109	0.109
1/2	0.84	Not BW	→	0.109	0.109	0.109	0.109	0.109



Procedure for the Resolution of Unknown Pipeline Features (PRUPF)

Nominal Diameter (Inches)	Diameter (Inches)	Seam Type	PURCHASE DATE TIME FRAME					
			See Section 3 if Purchase Date is Unknown					
			At or Prior to 02/25/1942	02/26/1942 to 02/11/1951	02/12/1951 to 11/23/1959	11/24/1959 to 01/16/1969	01/17/1969 to 08/28/1972	As of 08/29/1972
TYPICAL MINIMUM WALL THICKNESS (Inches)								
3/4	1.05	BW or Unknown	→	0.113	0.113	0.113	0.113	0.113
3/4	1.05	Not BW	→	0.113	0.113	0.113	0.113	0.113
1	1.315	BW or Unknown	→	0.133	0.133	0.133	0.133	0.113
1	1.315	Not BW	→	0.133	0.133	0.133	0.133	0.113
1-1/4	1.66	BW or Unknown	→	0.140	0.140	0.140	0.140	0.140
1-1/4	1.66	Not BW	→	0.140	0.140	0.140	0.140	0.140
1-1/2	1.9	BW or Unknown	→	0.145	0.145	0.145	0.145	0.145
1-1/2	1.9	Not BW	→	0.145	0.145	0.145	0.145	0.145
2	2.375	BW or Unknown	→	0.154	0.154	0.154	0.154	0.154
2	2.375	Not BW	→	0.154	0.154	0.154	0.154	0.154
3	3.5	BW or Unknown	→	0.148	0.148	0.156	0.141	0.156
3	3.5	Not BW	→	0.148	0.148	0.156	0.141	0.156
4	4.5	BW	→	0.148	0.148	0.148	Purchase ceased 10/26/1967	
4	4.5	SMLS	Consider exceptions presented in Table 4	06/14/1962 to 10/12/1964 0.107" 28k				
				06/14/1962 to 10/12/1964 0.156" 28k				
				01/01/1930 to 12/31/1930 0.109" 28k				
4	4.5	SMLS	→	0.148	0.148	0.156	0.156	0.148
4	4.5	ERW or Unknown	→	0.148	0.148	0.141	0.141	0.141



Procedure for the Resolution of Unknown Pipeline Features (PRUPF)

Nominal Diameter (Inches)	Diameter (Inches)	Seam Type	PURCHASE DATE TIME FRAME					
			See Section 3 if Purchase Date is Unknown					
			At or Prior to 02/25/1942	02/26/1942 to 02/11/1951	02/12/1951 to 11/23/1959	11/24/1959 to 01/16/1969	01/17/1969 to 08/28/1972	As of 08/29/1972
TYPICAL MINIMUM WALL THICKNESS (Inches)								
6	6.625	Any or Unknown	→	0.188	0.188	0.188	0.156	0.156
6	6.625	SW	Consider exceptions presented in Table 4 and as described in Figure 6.			0.169" WT with 06/17/1948 purchase date		
8	8.625	SW	→	0.217	0.188	0.188	0.172	0.172
8	8.625	Unknown or Not SW	0.188	0.217	0.188	0.188	0.172	0.172
8	8.625	SW	Consider exceptions presented in Table 4			0.169" WT with 12/21/1945 purchase date		
						0.322" WT with 08/21/1942 or earlier install date		
10	10.75	Any or Unknown	→	0.220	0.219	0.188	0.188	0.219
12	12.75	Any or Unknown	→	0.203	0.250	0.203	0.203	0.219
12	12.75	A.O. Smith	Consider exceptions presented in Table 4			0.203" WT with 08/07/1941 purchase date		
16	16	Any or Unknown	→	0.250	0.250	0.250	0.219	0.250
16	16	SSAW	Consider exceptions presented in Table 4			0.281" WT with 01/01/1953-12/31/1954 purchase date		
18	18	Any or Unknown	→	Assume this WT →		0.250	0.250	0.250
20	20	Any or Unknown	→	0.250	0.250	0.250	0.250	0.250



Procedure for the Resolution of Unknown Pipeline Features (PRUPF)

Nominal Diameter (Inches)	Diameter (Inches)	Seam Type	PURCHASE DATE TIME FRAME See Section 3 if Purchase Date is Unknown					
			At or Prior to 02/25/1942	02/26/1942 to 02/11/1951	02/12/1951 to 11/23/1959	11/24/1959 to 01/16/1969	01/17/1969 to 08/28/1972	As of 08/29/1972
TYPICAL MINIMUM WALL THICKNESS (Inches)								
22	22	Any or Unknown	→	Assume this WT →	0.312	0.312	0.250	0.250
24	24	SMLS	→	0.281	0.344	0.281	0.250	0.250
24	24	Not SMLS	→	0.312	0.344	0.281	0.250	0.250
26	26	Any or Unknown	→	0.312	0.312	0.312	0.297	0.281
30	30	Any or Unknown	→	Assume this WT →	0.250	0.250	0.312	0.325
32	32	Any or Unknown	→	Assume this WT →		0.375	0.375	0.375
34	34	Any or Unknown	→	Assume this WT →	0.250	0.250	0.312	0.375
36	36	Any or Unknown	→	Assume this WT →		0.312	0.312	0.406



Procedure for the Resolution of Unknown Pipeline Features (PRUPF)

5 UNKNOWN WELD FITTING SPECIFICATIONS

Unknown Weld Fitting Specifications Overview:

- 5.1 General
- 5.2 Fitting Seam Joint Efficiency
- 5.3 SMYS Testing
- 5.4 Wall Thickness Testing

Table Overview:

Table 6. Selecting WT and YS for Manufactured Bends (Elbows) and Weld Caps when both Specifications are Unknown (Use in Conjunction with Table 12)

Table 7. Selecting WT for Manufactured Bends (Elbows) and Weld Caps when YS is Known (Use in Conjunction with Table 12)

Table 8. Selecting YS for Manufactured Bends (Elbows) and Weld Caps when WT is Known

Table 9. Selecting WT and YS for Reducers and Tees when both Specifications are Unknown (Use in Conjunction with Table 12)

Table 10. Selecting WT for Reducers and Tees when YS is Known (Use in Conjunction with Table 12)

Table 11. Selecting YS for reducers and tees when WT is Known

Table 12. Wall Thickness for Fittings (Use in Conjunction with Tables 6-11)



Procedure for the Resolution of Unknown Pipeline Features (PRUPF)

5.1 General

1. This section contains the process to determine specification values for unknown fittings (weld ells, weld tees, weld caps, and weld reducers) with assumptions based on Company and industry historical information.
2. This process includes determination of suggestions for fitting specifications that are based on both the current and installed class location (if available).
 - a. The installed class location to determine unknown specifications in use must be entered into the PFL.
 - b. IF you believe that the current class location is the same as the installed class location,

THEN use fitting specifications suggested for the current class location.
 - c. IF it is possible that current class location is higher than that at time of installation,

THEN it is possible that fitting proposed by this process is stronger than those actually installed for the original class location—
therefore is NOT the most conservative specification application for this case.
 - d. IF it is possible that fitting proposed by this process is stronger than those actually installed for the original class location,

THEN consider reviewing with SME AND selecting a fitting that is no stronger than that needed for the installed class, or that is no stronger than the adjacent pipe.
 - e. IF the current class location is higher than the known class location at time of installation,

THEN select the fitting specifications based on the known installed class location instead of the current class location.



Procedure for the Resolution of Unknown Pipeline Features (PRUPF)

3. This section includes two instances where components installed after certain dates are assumed to be accomplished with specifications that met or exceeded the maximum allowable operating pressure (MAOP) of record (MAOP-R) at the time of installation.
 - a. Within limits set forth below and throughout Tables 6-11, adopt specifications sufficient to meet MAOP-R for all weld fittings (manufactured elbows, tees, reducers and caps) beginning on 03/01/1940. Company's Gas Standard 081260—effective 03/01/1940, required all weld elbows to meet design pressure requirements for the pipeline system at the time of installation. Policy in this document applies this requirement to all weld fittings.
 - b. Adopt specifications sufficient to meet MAOP-R for all pipeline components installed on or after 04/12/1963. Standard Practice 1604—signed on 04/12/1963, requires all pipeline components to meet MAOP-R for the pipeline system at the time of installation. See Attachment 1, "Standard Practice 1604 (1963)."
4. For purchase dates prior to 01/01/1930 or unknown time frame, assume 24 kpsi as minimum YS for installation.
5. Although Company has no records going back before 1940, Kiefner's "Joint Factors for Seam Welded Pipe Bends"—published on 08/20/2011, indicated that the likely minimum standard for fittings manufactured during the 1930s was Grade A, so for purchase date between 01/01/1930 and 02/28/1940, assume 30 kpsi Grade A as minimum YS. The 10 years shift addressed in Section 3 is applicable for fittings installed prior to 03/01/1930.
6. For installation dates on or after 03/01/1940, see Tables 6-11 to determine WT and grade assumptions for unknown specifications. This includes selecting assumptions to ensure that weld fitting specification combinations are sufficient to meet system MAOP-R, within limitations as set forth in the tables. Maximum fitting specification assumptions for some periods are limited; therefore, MAOP-R objectives may not always be met. In these instances, SME involvement is recommended to resolve issues.
7. In rare situations where diameter is unknown, do one of the following:
 - Perform a field assessment to measure diameter of the fitting in a single excavation at any location in the installation job. See:
 - "Implementation Responsibility" Section, Note 5, "MAOP Validation Process"
 - Section 7, "Field Assessment"
 - Develop assumptions as described in Section 4, "Unknown Pipe Specifications," Note 4.2, Item 2.



Procedure for the Resolution of Unknown Pipeline Features (PRUPF)

8. Do not make ten-year adjustments from purchase date to install date for weld fittings installed on and after 03/01/1940. This is because in this time frame, the standards applied only to installations, not purchase. See notations in Tables 6-11 for the application of this procedure.
9. The process to determine WT and grade for unknown specifications as found in:
 - Table 6, “Selecting WT and YS for Manufactured Bends (Elbows) and Weld Caps when both Specifications are Unknown (Use in Conjunction with Table 12)”
 - Table 7, “Selecting WT for Manufactured Bends (Elbows) and Weld Caps when YS is Known (Use in Conjunction with Table 12)”
 - Table 8, “Selecting YS for Manufactured Bends (Elbows) and Weld Caps when WT is Known”
 - Table 9, “Selecting WT and YS for Reducers and Tees when both Specifications are Unknown (Use in Conjunction with Table 12)”
 - Table 10, “Selecting WT for Reducers and Tees when YS is Known (Use in Conjunction with Table 12)”
 - Table 11, “Selecting YS for reducers and tees when WT is Known”
10. Class 4 location:
 - a. Assume all fittings in a Class 4 area installed prior to 07/01/1961—when CPUC General Order No. 112 and requirements for a Class 4 area became effective, met a Class 3 design factor of 0.5, UNLESS the installed class is known to be Class 4. This assumes Company did not observe the comparable class location issued in ASA B31.8 from 1955 -1960.
 - b. IF the unknown fitting under consideration is in a Class 4 location,

THEN the assumption above may result in a fitting pressure limit below the MAOP-R in a Class 4 location. A field investigation or system pressure reduction may be required and SME review is recommended.
11. IF fitting specification is inadequate OR MAOP-R is not validated after using Tables 6-11,

THEN consider the possibility that WT specified in job documents may be the thin end of fitting’s weld joint bevel, and that fitting’s nominal WT is the correct specification.
12. Implement the following guidelines when using Tables 6-11 to resolve unknown fitting specifications:



Procedure for the Resolution of Unknown Pipeline Features (PRUPF)

- a. Use the yield strength values that appear in the “Tests for MAOP Compatibility” columns in Tables 6-11 to test whether fitting specification assumption is sufficient to meet MAOP-R. Proceed to the steps in tables’ subsequent rows if fitting specification is inadequate.
- b. Legend for figures below:
 - Source is the term used for pipe and/or field bend (not manufactured bend, tee, or reducer)
 - Other is the term used for a non-pipe component, such as a valve.
- c. Select the larger WT value of the two adjacent sources to serve as source when an unknown WT fitting is welded to a source WT, as illustrated by this configuration:

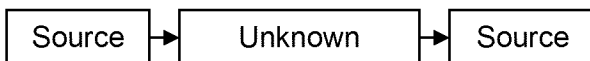

- d. Select the larger WT value of the sources on either side of the unknown fitting to serve as source when an unknown WT fitting is not welded to a source WT, as illustrated by this configuration:

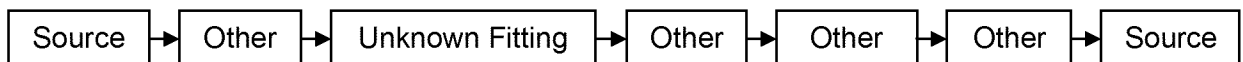

- e. Select the contiguous source WT value to serve as source when an unknown WT fitting is welded to only one side of a source WT, as illustrated by this configuration:

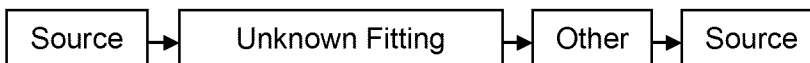

- f. IF no source has a valid WT OR no source is found,

THEN resolve fitting specifications through further investigation or deliberation (e.g., conduct further research of job documents and physical system configuration; adopt SME judgment, and/or conduct field inspection).
- g. The larger OD end of a reducer or a tee must be assessed relative to the corresponding pipe diameter specifications. The WT values for the smaller OD ends of reducers and tees are merely selected from Table 6 as the minimum needed to meet the intended service pressure.
- h. Since 03/01/1940, Company’s design standards for fittings required the use of ASTM A234/A106 Grade A (30 kpsi minimum YS) as minimum specification.



Procedure for the Resolution of Unknown Pipeline Features (PRUPF)

- i. The process employed by Tables 6-11 and the automated process in the PFL worksheet contain a bias to select thicker wall and lower strength fittings, because thicker wall and lower strength fittings are more commonly found in Company's system prior to and throughout the 1950's.

(1) IF

- You suspected that the fittings were likely to have a lighter WT, therefore, higher YS to achieve required pressure capabilities—to more closely match pipe WT,
- An order for a large number of fittings was placed prior to or throughout 1950's, which likely means for special, higher YS purchases,

THEN adopt specification combinations with a bias towards higher YS, thinner WT as described in Tables 6-11.

13. Tables 6-12 contain the following abbreviations:

- EH: Extra heavy
- kpsi: Kilopounds per square inch
- MAOP: Maximum allowable operating pressure
- OD: Outside diameter
- PFL: Pipeline feature list
- RM: Reference Manual
- SME: Subject matter expert
- WT: Wall thickness
- YS: Yield strength



Procedure for the Resolution of Unknown Pipeline Features (PRUPF)

Table 6. Selecting WT and YS for Manufactured Bends (Elbows) and Weld Caps when both Specifications are Unknown (Use in Conjunction with Table 12)

Step/Time Frame	DATE	WT column in Table 12	YS Choice
			Then Test for MAOP Compatibility
TIME FRAME 1, 2, and 3: Unknown or Pre-03/01/1940 Install Date NOTE: If purchase date is unknown, then make 10 year shift as indicated in Section 3.			
1	Unknown install and purchase date	Unknown time frame WT	24 kpsi
2	Prior to 01/01/1930 purchase date	Standard WT	24 kpsi
3	01/01/1930 to 02/28/1940 purchase date	Standard WT	30 kpsi
TIME FRAME 4 A, B, and C: 03/01/1940 to 04/11/1963 Install Date NOTE: Logic from this time forward is dependent on install dates only; purchase date is NOT employed.			
4A1	03/01/1940 to 04/11/1963 install date	If source WT is less than or equal to first choice WT, then choose first choice WT.	30 kpsi
4A2	03/01/1940 to 04/11/1963 install date	Standard WT	30 kpsi
4A3	03/01/1940 to 04/11/1963 install date	EH WT	30 kpsi
4A4	03/01/1940 to 04/11/1963 install date	EH WT	35 kpsi
4B1	03/01/1940 to 04/11/1963 install date	If source WT is greater than first choice WT and less than or equal to standard WT, then choose standard WT.	30 kpsi
4B2	03/01/1940 to 04/11/1963 install date	EH WT	30 kpsi
4B3	03/01/1940 to 04/11/1963 install date	EH WT	35 kpsi



Procedure for the Resolution of Unknown Pipeline Features (PRUPF)

Step/Time Frame	DATE	WT column in Table 12	YS Choice
			Then Test for MAOP Compatibility
4C1	03/01/1940 to 04/11/1963 install date	If source WT is greater than standard WT, then choose EH WT.	30 kpsi
4C2	03/01/1940 to 04/11/1963 install date	EH WT	35 kpsi
This point in the process is as far as the <u>PFL worksheet</u> goes. Steps beyond this point must be taken manually.			
TIME FRAME 4D: 01/01/1955 to 04/11/1963 Installed Date NOTE: Logic from this time forward is dependent on install dates only; purchase date is NOT employed.			
If a recommendation is contemplated for use of YS larger than 35 kpsi, then obtain technical peer review from those with sufficient experience to judge the validity of proposed solution.			
4D1	01/01/1955 to 04/11/1963 install date	Use standard or EH WT from above	42 kpsi
4D2	01/01/1955 to 04/11/1963 install date	Use standard or EH WT from above	52 kpsi
Special Case: TIME FRAME 4E: 03/01/1940 to 06/30/1961 Install Date for Class 4 Area NOTE: Logic from this time forward is dependent on install dates only; purchase date is NOT employed.			
See Section 5, "Unknown Weld Fitting Specifications," Note 5.1, Item 10 for Class 4 information regarding installations.			
4E	03/01/1940 to 06/30/1961 install date	If a fitting was installed in an area that subsequently increased to a Class 4 area AND the installed class cannot be determined, then assume the design factor was 0.5 for fitting selections and ensure a SME review is conducted.	



Procedure for the Resolution of Unknown Pipeline Features (PRUPF)

Step/Time Frame	DATE	WT column in Table 12	YS Choice
			Then Test for MAOP Compatibility
TIME FRAME 5A, B, C, D and E: 04/12/1963 to 10/31/1968 Install Date NOTE: Logic from this time forward is dependent on install dates only; purchase date is NOT employed.			
5A1	04/12/1963 to 10/31/1968 install date	If source WT is less than or equal to first choice WT, then choose first choice WT.	35 kpsi
5A2	04/12/1963 to 10/31/1968 install date	Choose standard WT	35 kpsi
5A3	04/12/1963 to 10/31/1968 install date	Choose EH WT	35 kpsi
5A4	04/12/1963 to 10/31/1968 install date	Choose source WT if it is greater than EH WT.	35 kpsi
5B1	04/12/1963 to 10/31/1968 install date	If source WT is greater than first choice WT and less than or equal to standard WT, then choose standard WT.	35 kpsi
5B2	04/12/1963 to 10/31/1968 install date	Choose EH WT	35 kpsi
5B3	04/12/1963 to 10/31/1968 install date	Choose source WT if it is greater than EH WT	35 kpsi
5C1	04/12/1963 to 10/31/1968 install date	If source WT is greater than standard WT, then choose EH WT.	35 kpsi
5C2	04/12/1963 to 10/31/1968 install date	Choose source WT if it is greater than EH WT.	35 kpsi
If a recommendation is contemplated for use of YS greater than 35 kpsi, then obtain technical peer review from those with sufficient experience to judge the validity of proposed solution.			
5D1	04/12/1963 to 10/31/1968 install date	Use final WT from above	42 kpsi
5D2	04/12/1963 to 10/31/1968 install date	Use final WT from above	52 kpsi



Procedure for the Resolution of Unknown Pipeline Features (PRUPF)

Step/Time Frame	DATE	WT column in Table 12	YS Choice
			Then Test for MAOP Compatibility
This point in the process is as far as the <u>PFL worksheet</u> goes. Steps beyond this point must be taken manually.			
5E1	04/12/1963 to 10/31/1968 install date	Use any WT from above	60 kpsi
<p align="center">TIME FRAME 6: 11/01/1968 Install Date to Present</p> <p>In addition to the logic for time frame 5 (above), consider using the fitting WT values in Table 12, "Unknown Installed Date" column as alternatives to the WT choices employed in time frame 5 because these values appeared in this 1968+ date range in Company's standards.</p>			

Procedure for the Resolution of Unknown Pipeline Features (PRUPF)

Table 7. Selecting WT for Manufactured Bends (Elbows) and Weld Caps when YS is Known (Use in Conjunction with Table 12)

Step/Time Frame	DATE	WT column in Table 12	YS
		Then Test for MAOP Compatibility	
TIME FRAME 1, 2, and 3: Unknown or Pre-3/1/40 Install Date NOTE: If purchase date is unknown, then make 10 year shift as indicated in Section 3.			
1	Unknown install and purchase date	Unknown time frame WT	Use known YS
2	Prior to 01/01/1930 purchase date	Standard WT	Use known YS
3	01/01/1930 to 02/28/1940 purchase date	Standard WT	Use known YS
TIME FRAME 4A: 03/01/1940 to 04/11/1963 Install Date NOTE: Logic from this time forward is dependent on install dates only; purchase date is NOT employed.			
4A1	03/01/1940 to 04/11/1963 install date	If source WT is less than or equal to first choice WT, then choose first choice WT.	Use known YS
4A2	03/01/1940 to 04/11/1963 install date	Standard WT	Use known YS
4A3	03/01/1940 to 04/11/1963 install date	EH WT	Use known YS
Special Case: TIME FRAME 4E: 03/01/1940 to 06/30/1961 Install Date for Class 4 Area			
See Section 5, "Unknown Weld Fitting Specifications," Note 5.1, Item 10 for Class 4 information regarding installations.			
4E	03/01/1940 to 06/30/1961 install date	If a pipeline system was installed in an area that subsequently increased to a Class 4 area AND the installed class cannot be determined, then assume the design factor was 0.5 for fitting selections and ensure a SME review is conducted.	



Procedure for the Resolution of Unknown Pipeline Features (PRUPF)

Step/Time Frame	DATE	WT column in Table 12	YS
		Then Test for MAOP Compatibility	
TIME FRAME 5A, B, and C: 04/12/1963 to 10/31/1968 Install Date			
5A1	04/12/1963 to 10/31/1968 install date	If source WT is less than or equal to first choice WT, then choose first choice WT.	Use known YS
5A2	04/12/1963 to 10/31/1968 install date	Choose standard WT	Use known YS
5A3	04/12/1963 to 10/31/1968 install date	Choose EH WT	Use known YS
5A4	04/12/1963 to 10/31/1968 install date	Choose source WT if it is greater than EH WT.	Use known YS
5B1	04/12/1963 to 10/31/1968 install date	If source WT is greater than first choice WT and less than or equal to standard WT, then choose standard WT.	Use known YS
5B2	04/12/1963 to 10/31/1968 install date	Choose EH WT	Use known YS
5B3	04/12/1963 to 10/31/1968 install date	Choose source WT if it is greater than EH WT.	Use known YS
5C1	04/12/1963 to 10/31/1968 install date	If source WT is greater than standard WT, then choose EH WT.	Use known YS
5C2	04/12/1963 to 10/31/1968 install date	Choose source WT if it is greater than EH WT.	Use known YS
TIME FRAME 6: 11/01/1968 Install Date to Present			
<p>In addition to the logic for time frame 5 (above), consider using the fitting WT values in Table 12, "Unknown Installed Date" column as alternatives to the WT choices employed in time frame 5 because these values appeared in this 1968+ date range in Company's standards.</p>			

Procedure for the Resolution of Unknown Pipeline Features (PRUPF)

Table 8. Selecting YS for Manufactured Bends (Elbows) and Weld Caps when WT is Known

Step/Time Frame	DATE	WT column in Table 12	YS Choice
			Then Test for MAOP Compatibility
TIME FRAME 1, 2, and 3: Unknown or Pre-03/01/1940 Install Date NOTE: If purchase date is unknown, then make 10 year shift as indicated in Section 3.			
1	Unknown install and purchase date	Use known WT	24 kpsi
2	Prior to 01/01/1930 purchase date	Use known WT	24 kpsi
3	01/01/1930 to 02/28/1940 purchase date	Use known WT	30 kpsi
TIME FRAME 4A: 03/01/1940 to 04/11/1963 Install Date NOTE: Logic from this time forward is dependent on install dates only; purchase date is NOT employed.			
4A1	03/01/1940 to 04/11/1963 install date	Use known WT	30 kpsi
4A2	03/01/1940 to 4/11/1963 install date	Use known WT	35 kpsi
This point in the process is as far as the <u>PFL worksheet</u> goes. Steps beyond this point must be taken manually.			
TIME FRAME 4B: 01/01/1955 to 04/11/1963 Install Date			
If a recommendation is contemplated for use of YS greater than 35 kpsi, then obtain technical peer review from those with sufficient experience to judge the validity of proposed solution.			
4B1	01/01/1955 to 04/11/1963 install date	Use known WT	42 kpsi
4B2	01/01/1955 to 04/11/1963 install date	Use known WT	52 kpsi



Procedure for the Resolution of Unknown Pipeline Features (PRUPF)

Step/Time Frame	DATE	WT column in Table 12	YS Choice
			Then Test for MAOP Compatibility
Special Case:			
TIME FRAME 4E: 03/01/1940 to 06/30/1961 Install Date for Class 4 Area			
See Section 5, "Unknown Weld Fitting Specifications," Note 5.1, Item 10 for Class 4 information regarding installations.			
4E	03/01/1940 to 06/30/1961 install date	If a pipeline system was installed in an area that subsequently increased to a Class 4 area AND the installed class cannot be determined, then assume the design factor was 0.5 for fitting selections and ensure a SME review is conducted.	
TIME FRAME 5A, B, and E: 04/12/1963 to 10/31/1968 Install Date			
5A1	04/12/1963 to 10/31/1968 install date	Use known WT	35 kpsi
If a recommendation is contemplated for use of YS larger than 35 kpsi obtain technical peer review from others with sufficient experience to judge the validity of the proposed solution.			
5B1	04/12/1963 to 10/31/1968 install date	Use known WT	42 kpsi
5B2	04/12/1963 to 10/31/1968 install date	Use known WT	52 kpsi
This point in the process is as far as the <u>PFL worksheet</u> goes. Steps beyond this point must be taken manually.			
5E1	04/12/1963 to 10/31/1968 install date	Use known WT	60 kpsi
TIME FRAME 6: 11/01/1968 Install Date to Present			
In addition to the logic for time frame 5 (above), consider using the fitting WT values in Table 12, "Unknown Installed Date" column as alternatives to the WT choices employed in time frame 5 because these values appeared in this 1968+ date range in Company's standards.			

Procedure for the Resolution of Unknown Pipeline Features (PRUPF)

Table 9. Selecting WT and YS for Reducers and Tees when both Specifications are Unknown (Use in Conjunction with Table 12)

Step/Time Frame	DATE	WT column in Table 12	YS Choice
			Then test for MAOP Compatibility
TIME FRAME 1, 2, and 3: Unknown or Pre-03/01/1940 Install Date NOTE: If purchase date is unknown, then make 10 year shift as indicated in Section 3.			
1	Unknown install and purchase date	Unknown time frame WT	24 kpsi
2	Prior to 01/01/1930 purchase date	Standard WT	24 kpsi
3	01/01/1930 to 02/28/1940 purchase date	Standard WT	30 kpsi
TIME FRAME 4A, B, and C: 03/01/1940 Install Date to Present NOTE: Logic from this time forward is dependent on install dates only; purchase date is NOT employed.			
4A	Determine specifications for larger OD (could be either OD 1 or OD 2 on <u>PFL worksheet</u>). Proceed as set forth on Table 6 to establish WT and YS suggestions.		
4B	Determine WT for smaller OD (could be either OD 1 or OD 2 on <u>PFL worksheet</u>). Begin with WT from unknown install date (most conservative) column of Table 12, test for MAOP compatibility. Increase WT suggestions through first choice, second choice, and up to a maximum of third choice.		
This point in the process is as far as the <u>PFL worksheet</u> goes. Steps beyond this point must be taken manually.			
4C	With input from SME, consider higher WT values if necessary to meet MAOP.		



Procedure for the Resolution of Unknown Pipeline Features (PRUPF)

Table 10. Selecting WT for Reducers and Tees when YS is Known (Use in Conjunction with Table 12)

Step/Time Frame	DATE	WT column in Table 12	YS Choice
			Then Test for MAOP Compatibility
TIME FRAME 1, 2, and 3: Unknown or Pre-03/01/1940 Install Date NOTE: If purchase date is unknown, then make 10 year shift as indicated in Section 3.			
1	Unknown install and purchase date	Unknown time frame WT	Use known YS
2	Prior to 01/01/1930 purchase date	Standard WT	Use known YS
3	01/01/1930 to 02/28/1940 purchase date	Standard WT	Use known YS
TIME FRAME 4A, B, and C: 03/01/1940 Install Date to Present NOTE: Logic from this time forward is dependent on install dates only; purchase date is NOT employed.			
4A	Determine specifications for larger OD (could be either OD 1 or OD 2 on a PFL). Proceed as set forth on Table 7 to establish WT suggestions.		
4B	Determine WT for smaller OD (could be either OD 1 or OD 2 on a PFL). Begin with WT from unknown install date (most conservative) column in Table 6, test for MAOP compatibility. Increase WT suggestions through first choice, second choice, and up to a maximum of third choice until MAOP compatibility is attained.		
This point in the process is as far as the <u>PFL worksheet</u> goes. Steps beyond this point must be taken manually.			
4C	With input from SME, consider higher WT values if necessary to meet MAOP.		



Procedure for the Resolution of Unknown Pipeline Features (PRUPF)

Table 11. Selecting YS for Reducers and Tees when WT is Known

Step/Time Frame	DATE	WT	YS Choice
			Then test for MAOP Compatibility
TIME FRAME 1, 2, and 3: Unknown or Pre-03/01/1940 Install Date			
1	Unknown install and purchase date	Use Known WT	24 kpsi
2	Prior to 01/01/1930 purchase date	Use Known WT	24 kpsi
3	01/01/1930 to 02/28/1940 purchase date	Use Known WT	30 kpsi
TIME FRAME 4A and B: 03/01/1940 Install Date to Present			
NOTE: Logic from this time forward is dependent on install dates only; purchase date is NOT employed.			
4A	Determine specifications for larger OD (could be either OD 1 or OD 2 on a PFL) Proceed as set forth on Table 8 to establish YS suggestions.		
4B	Determine specifications for smaller OD (could be either OD 1 or OD 2 on a PFL) Adopt assumed YS from step 4A (right above) and known WT.		

14. Company continues to gather data prior to 03/01/1940 on fitting WT to confirm the WT values are appropriate. The only exceptions found as of 09/10/2011 are 16-inch and 24-inch fittings. Minimum WT value has been reduced from 0.375-inch in Table 12 to reflect this finding.
15. Use WT values for fittings presented in Table 12 when following the steps in Tables 6-11 for cases where fitting WT is unknown. The specification of fitting WT relies on knowing the adjacent or nearby pipe or field bend (source component) WT.



Procedure for the Resolution of Unknown Pipeline Features (PRUPF)

Table 12. Wall Thickness for Fittings (Use in Conjunction with Tables 6-11)

Nominal Size (Inches)	Actual Diameter	Wall Thickness (Inches)				Use Source
		Unknown Install Date	First Choice	Second Choice Standard	Third Choice EH	
3/8	0.500	Unknown				Source WT
1/2	0.840	0.109	0.109	0.109	0.109	
3/4	1.050	0.113	0.113	0.113	0.154	
1	1.320	0.133	0.133	0.133	0.179	
1-1/4	1.660	0.140	0.140	0.140	0.191	
1-1/2	1.900	0.145	0.145	0.145	0.200	
2	2.375	0.154	0.154	0.154	0.218	
3	3.500	0.188	0.216	0.216	0.300	
4	4.500	0.188	0.237	0.237	0.337	
6	6.625	0.219	0.280	0.280	0.432	
8	8.625	0.219	0.322	0.322	0.500	
10	10.750	0.219	0.365	0.365	0.500	
12	12.750	0.250	0.375	0.375	0.500	
14	N/A					
16	16.000	0.250	0.312	0.375	0.500	
18	18.000	0.375	0.375	0.375	0.500	
20	20.000	0.375	0.375	0.375	0.500	
22	22.000	0.375	0.375	0.375	0.500	
24	24.000	0.312	0.312	0.375	0.500	
26	26.000	0.375	0.375	0.375	0.500	
30	30.000	0.375	0.375	0.375	0.500	
32	32.000	0.375	0.375	0.375	0.500	
34	34.000	0.375	0.375	0.375	0.500	
34-1/2	34.500	N/A				
36	36.000	0.375	0.375	0.375	0.500	



Procedure for the Resolution of Unknown Pipeline Features (PRUPF)

5.2 Fitting Seam Joint Efficiency

1. When working with factory-made bends that were manufactured during and after 1940 from a plate with edges joined at one or two welded seams, use a joint efficiency factor of 1.0 for fitting weld seams.
2. Fittings greater than 12-inch diameter manufactured prior to 1940 may have long seams. Such fittings with seams are unlikely but possible. SME review is recommended to assess whether long seams should be assumed and to establish joint efficiency factor. In that case, review the circumstances with document owner of this procedure to support improving Company's broader understanding of these components.

5.3 SMYS Testing

1. Conduct a field investigation when SMYS prevents validation of MAOP:
 - As part of the field investigation, capture SMYS data for future use and to validate the assumption provided by PRUPF.
 - IF an MAOP higher than that provided in PRUPF is desired,
THEN conduct destructive testing as specified in 49 CFR 192, Appendix A.II.D.
2. Perform a field assessment to measure the SMYS of the fitting. See:
 - "Implementation Responsibility" Section, Note 5, "MAOP Validation Process"
 - Section 7, "Field Assessment"
 - "Before You Start" Section, Note 1.1

5.4 Wall Thickness Testing

1. In instances where Company recommends using values different from those resulting from the procedure outlined here, Company must conduct a field investigation to establish WT. For example when value produced in this procedure results in an MAOP-D below the MAOP-R, a pressure reduction may be necessary unless a field investigation is conducted to establish WT or to validate MAOP-R.
2. Perform a field assessment to test WT of the feature in a single excavation at any location within the range of original installation job. See:
 - "Implementation Responsibility" Section, Note 5, "MAOP Validation Process"
 - Section 7, "Field Assessment"
 - "Before You Start" Section, Note 1.1



Procedure for the Resolution of Unknown Pipeline Features (PRUPF)

6 PIPELINE COMPONENTS

Pipeline Components Overview:

6.1 General

6.2 Sleeves

Table Overview:

Table 13. Wall Thickness for Sleeves from 01/04/1945 to 01/16/1963

Table 14. Yield Strength for Sleeves from 01/17/1963 to 07/05/1964

Table 15. Yield Strength for Sleeves from 07/06/1964 to 03/25/1968

Table 16. Yield Strength for Sleeves from 03/26/1968 to 12/07/1992



Procedure for the Resolution of Unknown Pipeline Features (PRUPF)

6.1 General

1. Pipeline components consist of sleeves, valves, regulators, and other pressure containing components for which specifications are not sufficiently understood from PFL build process to calculate MAOP-D.
2. This section contains information needed to select specifications—based on the assumption that components installed on and after 04/12/1963 meet or exceed MAOP-R for the equipment as installed for the pipeline system. See Note 5.1 Item 3b.
3. Use the following requirements to choose specifications:
 - a. Design pressure employed for components are the values in references below and as close as possible to installation date:
 - Company's 1968 CPUC Filing "Initial Report of Pipelines and Mains Operating at or above 20% SMYS" – 03/27/1969. Use the listed MAOP.
 - Company's 1974-1975 MAOP Study. Use the listed design pressure.
 - Company's 086868 Pipeline Data Sheet, MAOP of Lines Operating at or Above 20% SMYS, Revision 0 and subsequent revisions.

NOTE

The updated MAOP cannot be used as a basis for selecting component assumptions.

- b. IF the pipeline has been updated—MAOP increased subsequent to installation in accordance with 49 CFR Part 192, Subpart K, "Upgrading",

THEN use the previously established MAOP.
4. In 1972, American National Standards Institute (ANSI) ratings were increased slightly from the long-standing values found in Company's records, though Company did not follow suit. In situations after 1972, the newer and higher ratings can be used if they would improve conformance to MAOP of a pipeline system. SME review is required.
5. Company's policy regarding adjustments for unknown Company purchase date is applicable only to purchase install dates—as described in Section 3, "Adjustments for Unknown Company Purchase Date," NOT installation purchase dates. Because the adoption of specifications that meet MAOP-R is based on installation dates, do not perform ten-year adjustments for any component installed on and after 04/12/1963, or weld ells, tees, reducers and caps installed on or after 03/01/1940.



Procedure for the Resolution of Unknown Pipeline Features (PRUPF)

6. Other Pre-04/12/1963 rated fittings:
 - a. IF you encounter components that should but do not have known pressure ratings,

THEN conduct a field investigation to measure dimensions and look for rating information. See:
 - (1) "Implementation Responsibility" Section of this document, Note 5, "MAOP Validation Process"
 - (2) Section 7, "Field Assessment"
 - (3) "Before You Start" Section, Note 1.1

6.2 Sleeves

1. IF a sleeve not a tie-in sleeve—used only for repair and pipe body remains intact to carry axial loading,

THEN use a WT ratio of 1.0 – minimum required for welding sleeves with the same YS as pipe, to meet design pressure for line pipe.
2. Welding sleeves installed prior to 01/04/1945:
 - a. Company has found no records of weld sleeves installed prior to 01/04/1945. When in doubt, assume specifications are those installed after 01/04/1945— See Table 13, "Wall Thickness for Sleeves from 01/04/1945 to 01/16/1963."
3. Welding sleeves installed between 01/04/1945 and 01/16/1963:
 - a. Use 30 kpsi YS associated with 60,000 minimum tensile strength. This is confirmed as the most conservative approach by Company's historical standard for welding sleeves—*1944 Book of A.S.T.M. Standards (ATSM, January 1945)*. See API Specification 5L for more detail.
 - b. Calculate OD of sleeve as follows, including the use of a 0.25-inch allowance for gap between the sleeve ID and the pipe OD:

Equation 1:

$$\text{Sleeve OD} = \text{Pipe OD} + (2 \times \text{sleeve WT}) + 0.25''$$

- c. Based on Company's engineering practices for the time period, Table 13, "Wall Thickness for Sleeves from 01/04/1945 to 01/16/1963" contains assumptions for minimum WT values when sleeve WT values are unknown.



Procedure for the Resolution of Unknown Pipeline Features (PRUPF)

- To meet design pressure for line pipe, use WT ratio of 1.42 as the minimum required for welding sleeves with the same YS as pipe:

Equation 2:

$$\frac{\text{Sleeve WT}}{\text{Pipe WT}} \geq 1.42$$

- Adjust line pipe WT ratio – required for welding sleeves to meet MAOP-D, with ratio of sleeve material YS to pipe material YS as follows:

Equation 3:

$$\frac{\text{Sleeve WT}}{\text{Pipe WT}} \times \frac{\text{Sleeve YS}}{\text{Pipe YS}} \geq 1.42$$

Table 13. Wall Thickness for Sleeves from 01/04/1945 to 01/16/1963

Nominal Pipe Size (Inches)	Maximum Gas Working Pressure	Minimum Pipe WT	Minimum Sleeve WT
3	800	0.148	0.187
4	800	0.148	0.187
6	800	0.188	0.250
8	800	0.220	0.312
10	800	0.259	0.375
10	500	0.203	0.375
12	800	0.312	0.437
12	500	0.203	0.312
16	800	0.401	0.500
16	500	0.250	0.375
20	500	0.281	0.437
22	500	0.312	0.437
24	500	0.281	0.500
26	500	0.375	0.500



Procedure for the Resolution of Unknown Pipeline Features (PRUPF)

- 6. Welding sleeves installed from 01/17/1963 to 07/05/1964:
 - a. Use Table 14, "Yield Strength for Sleeves from 01/17/1963 to 07/05/1964" to determine YS assumption for sleeves.
 - b. To determine sleeve WT assumption, multiply 1.42 by WT of line pipe. Use WT increments of 1/16-inch. This means, determine the exact WT value needed, and then round up to the next 1/16-inch increment.
 - c. Use Equations 2 and 3 (see Note 6.2, Items 4 and 5) to assess 1.42 MAOP-D.

Table 14. Yield Strength for Sleeves from 01/17/1963 to 07/05/1964

Outside Diameter Pipe Size (Inches)	MAOP-D and Material YS	
	175-720 MAOP	Greater than 720 MAOP
4	35,000	50,000 minimum
6-16	42,000	50,000 minimum
18-36	50,000 minimum	50,000 minimum

- 7. Welding sleeves installed from 07/06/1964 to 03/25/1968:
 - a. Use Table 15, "Yield Strength for Sleeves from 07/06/1964 to 03/25/1968" to determine YS assumption for sleeves.
 - b. Consider 50 kpsi YS material as standard sleeve because records indicated that it exists.
 - c. To determine sleeve WT assumption, multiply 1.42 by WT of line pipe. Use WT increments of 1/16-inch. This means, determine the exact WT value needed, and then round up to the next 1/16-inch increment.
 - d. Use Equations 2 and 3 (see Note 6.2, Items 4 and 5) to assess 1.42 MAOP-D.

Table 15. Yield Strength for Sleeves from 07/06/1964 to 03/25/1968

Outside Diameter Pipe Size (Inches)	Sleeve Material
4-16	Greater than or equal to pipe material
18-36	Greater than or equal to pipe material 50,000 available



Procedure for the Resolution of Unknown Pipeline Features (PRUPF)

8. Welding sleeves installed from 03/26/1968 to 12/07/1992:
 - a. Use Table 16, "Yield Strength for Sleeves from 03/26/1968 to 12/07/1992" to determine YS assumption for sleeves.
 - b. To determine sleeve WT assumption, multiply 1.42 by WT of line pipe. Use WT increments of 1/16-inch. This means, determine the exact WT value needed, and then round up to the next 1/16-inch increment.
 - c. Use Equations 2 and 3 (see Note 6.2, Items 4 and 5) to assess 1.42 MAOP-D.

Table 16. Yield Strength for Sleeves from 03/26/1968 to 12/07/1992

Carrier Pipe Grade	Sleeve Minimum YS
B	38,000
X-42, 46, 48	50,000
X-52, 60	60,000
X-65	65,000
X-70	70,000

9. Welding sleeves less than or equal to 16-inch installed on and after 12/08/1992:
 - a. Use Table 16 (above) to determine YS assumption for sleeves.
 - b. Choose sleeve YS greater than or equal to pipe SMYS.
 - c. To determine sleeve WT assumption, multiply 1.42 by WT of line pipe. Use WT increments of 1/16-inch. This means, determine the exact WT value needed, and then round up to the next 1/16 inch increment.
10. Welding sleeves for pipe greater than 16 inches installed on and after 12/08/1992:
 - a. Use Table 16 to determine YS assumption for sleeves.
 - b. Choose sleeve YS greater than or equal to pipe SMYS.
 - c. To determine WT assumption for sleeves equaled to or larger than 18 inches in diameter, use calculated values from Gas Numbered Document A-60, "Gas Main Welding Sleeves (Type B Sleeves with Circumferential Welds)" and WT increments of 1/16 inch. See Figure 9, "Sleeve Thickness and Circumferential Fillet Design for Pipe with Diameter Greater than or Equal to 18" OD and Larger Pipe".



Procedure for the Resolution of Unknown Pipeline Features (PRUPF)

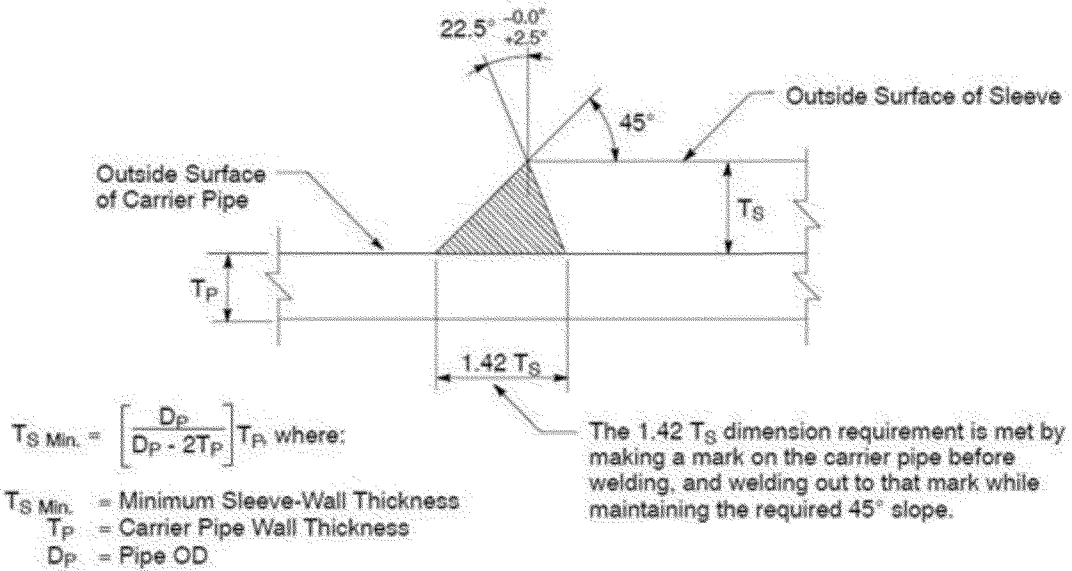

Note: This formula is only valid when the yield strength of the sleeve is greater than or equal to that of the carrier pipe, and the sleeve has a design pressure equal to that of the pipe.

Figure 9, Sleeve Thickness and Circumferential Fillet Design for Pipe with Diameter Greater than or Equal to 18" OD and Larger Pipe



Procedure for the Resolution of Unknown Pipeline Features (PRUPF)

7 FIELD ASSESSMENT

Field Assessment Overview:

- 7.1 General
- 7.2 Diameter
- 7.3 Wall Thickness
- 7.4 Material Strength
- 7.5 Longitudinal Seam Type
- 7.6 Girth Weld Type
- 7.7 Coating and Excavation Data Gathering Methods

Table Overview:

Table 17. Field Assessment Summary



Procedure for the Resolution of Unknown Pipeline Features (PRUPF)

7.1 General

1. Record detailed information of requirements found in excavation process that fall outside the scope of field assessment techniques presented in this section (e.g., special diameter measurements, etc.).

7.2 Diameter

1. Wrap a "Pi" tape around pipe to measure circumference. Pi tape is a flexible tape measurement that was calibrated and marked to display diameter.
2. Pi tape uses a circumference measurement – in inches, to minimize potential errors in calculation. It has accuracy sufficient enough to easily identify standard pipe diameters, even with the presence of pipe coating and a modest amount of dirt.
3. See API Specification 5L (Section 10.2.8, Page 66, 10/01/2008 or a newer edition) for instruction to use Pi tape.

7.3 Wall Thickness

1. Adhere to manufacturer's instructions and Company's regulations regarding equipment calibration when operating Ultrasonic Test (UT) equipment.
2. Use UT equipment to measure pipe WT circumferentially at 12 o'clock, nine o'clock, six o'clock, and three o'clock positions in accordance to 49 CFR Part 192.109, "Nominal Wall Thickness (t) for Steel Pipe."
3. The WT Tool process (see AKM-MAOP-420G, "MAOP Data Validation Project Wall Thickness Tool") determines the appropriate commercially available nominal WT for use in MAOP calculations, "Gas Pipeline Pressure Limit Calculation Guide." Use it to analyze WT values.
4. See a list of commercially available WT by pipe size in Appendix B, "Commercially Available Pipe Wall Thickness Values."

7.4 Material Strength

1. Consider the following approaches to determine or confirm material YS in the field:
 - a. Instrumented Indentation Testing (IIT)
 - (1) Use IIT test methodology to provide predictions that correlate to API Specification 5L YS of Company's in-service pipe, within specific confidence bounds, as suitable to supplement Company's methodology to predict pipeline YS when complete information is not available.
 - (2) Employ IIT testing process when field investigation is performed to validate previously drawn conclusions from historical references and documentation.



Procedure for the Resolution of Unknown Pipeline Features (PRUPF)

- (3) Refer to the following Company's documents:
 - Applied Technology Services (ATS) Numbered Document ATS 357.MT.05, "Instrumented Indentation Testing (IIT) Procedure" (01/31/2013 draft) for IIT data gathering.
 - "ATS-IIT Assessment Summary" (exponent 03/29/2013)
- b. Metal composition testing:
 - (1) An alloy analysis of pipe steel sometimes reveals clues about the identification of pipe manufacturing specification. This process uses portable analysis equipment that operates based on arc-spark optical emissions spectrometry to analyze chemistry found in pipe against known chemistry used in various pipe manufacturing specifications. For instructions to operate analysis equipment, see Applied Technology Services (ATS) Numbered Document ATS.357.MT.01, "Arc-Met 930SP and Arc-Met 8000."
 - (2) Destructive testing of pipe wall material samples can help to determine tensile properties. See API Specification 5L and 49 CFR Part 192.107, "Yield Strength (S) for Steel Pipe" for additional requirements.

7.5 Longitudinal Seam Type

1. Use the following resources to identify longitudinal seam type:
 - a. *History of Line Pipe Manufacturing in North America* for reference photographs and other details to support longitudinal seam weld identification.
 - b. Gas numbered document A-11, "Identification of Steel Pipe" for visual inspection procedure to identify longitudinal seam and other characteristics that occurred as the result of manufacturing methods and for information regarding field investigation of certain weld seams.
 - c. Company's Applied Technology Services (ATS) Longitudinal Weld Seam Datasheet to assist data gathering process.
 - d. EMG (Pre-1970 Course Material) for reference information regarding vintage pipeline features and construction including longitudinal seam welding and their photographs. It supplements historical seam type references, and those that aid in visual identification of longitudinal seam and other features.
2. Types of longitudinal seams:
 - Seamless
 - Butt weld
 - Lap weld



Procedure for the Resolution of Unknown Pipeline Features (PRUPF)

- Vintage AOS
 - Modern AOS
 - Electric resistance weld
 - Single submerged arc weld
 - Double submerged arc weld
3. Field Identification Process:
- a. Distinguishing SSAW from DSAW:
- (1) Select and clean a section of the seam.
 - (2) Perform radiography to ensure weld does not have any imperfections that would create a safety issue when grinding weld seam cap down to flush with adjacent outer pipe wall. Perform radiography in accordance with:
 - Company's ATS Procedure for Radiographic Examination of Pipe Welds
 - Company's ATS Validation of DSAW vs. SSAW Characterization Using Radiography Method
 - "Radiographic Examination" (ASME Section V Article 2) and "Nondestructive Examination (NDE)" (ASME Article 22 SE 94)
 - (3) Inspect the quality of the proposed seam weld lengths. A length of approximately four to six inches is usually adequate. Areas used in this test must be free of all rounded or linear indications.
 - (4) Grind a length of four inches off weld cap.
 - (5) Smooth exterior surface of pipe and seam weld to create a uniform surface across the seam. This improves quality of the next radiograph and allows further examination of seam type.
 - (6) Perform a second radiograph of the dressed area that allows clear visual identification of pipe's inside seam weld surface, such as:
 - Weld cap for DSAW
 - Root characteristics for SSAW
 - (7) Perform a final magnetic particle inspection to ensure that grinding process did not expose imperfections. If imperfections are found, they may require further assessment and repair. Complete magnetic particle inspection in accordance with:
 - Company's ATS Magnetic Particle Inspection Procedure



Procedure for the Resolution of Unknown Pipeline Features (PRUPF)

- Company's ATS Pipe Seam Type Determination Procedure
 - "Magnetic Particle Examination" (ASME Section V Article 7) and "Magnetic Particle Standards" (ASME Article 25 SE 709)
- b. AOS:
- (1) AOS longitudinal seam is formed with two types of the electric flash welding process:
 - Earlier or vintage AOS (possibly earlier than 1942) included an outside arc weld seam that can be distinguished by visual examination and verified through radiograph process.
 - Later or modern AOS seams lack the external arc weld cap and are similar in appearance to ERW except that the upset metal is not trimmed as close to the pipe surfaces. The pipe was cold expanded during manufacturing, which supports the use of E=1.0.
- c. Other Seam Weld Types:
- (1) Inspect seam visually and use pipe historical records to identify seam types. Seam weld features visible on outside surface of pipe are characteristics of various seam types.
 - (2) IF weld seam is not apparent from visual inspection,
THEN perform steps 3-6 below.
 - (3) Clean an area using a minimum of 240 grit paper where seam might exist.
 - (4) Apply 10% nitric acid to prep area to aid in visual inspection.
 - (5) Confirm that seam exists.
 - (6) IF no seam is found,
THEN repeat the above Steps 3-5 for 180 degrees on the top half of the pipe.
 - (7) Perform a 12-point UT that verifies seam type to differentiate seamless from solid-state welding processes (ERW, Lap, Modern AOSmith Furnace Butt, etc.).

7.6 Girth Weld Type

1. Clean external pipe weld area.
2. Photograph area.



Procedure for the Resolution of Unknown Pipeline Features (PRUPF)

3. Use historical data and visual inspection to identify girth weld type.
4. Record whether shielded metal arc welded (SMAW) pipe, gas metal arc welded (GMAW) pipe, etc. was used, or if it could be a submerged arc welded (SAW) pipe that was rolled in the mill, etc.

7.7 Coating and Excavation Data Gathering Methods

1. Company standard of practice when performing excavations for any field investigation described in this procedure require that all data gathered during an exposed pipeline investigation is recorded in H-Form "Inspection and Long Seam Characterizations."
2. See H-Form for more information.
3. See Standard 7100 Procedures for Pipe Removed for Cause for more details.

Table 17. Field Assessment Summary

Desired Property	Method	Description	Investigation Frequency
Diameter	Measure Pipe Circumference	Use Pi tape to measure circumference of pipe.	Measure circumference of pipe in two areas for each excavation and diameter. Record both measures in <u>H-Form</u> .
Wall Thickness	Ultrasonic Inspection	An electronic instrument measures WT of a solid structure, such as a pipe wall.	Perform 12 measurements around pipe circumference at quarter points, within a single excavation. Record results in <u>H-Form</u> .
Grade / SMYS	Laboratory Analysis	Remove sections of pipe wall for testing by installing two pressure control fittings on pipeline or removing pipeline from service. Perform destructive lab testing on coupon to determine tensile properties.	This test is rarely used. If desired (per location job package), then perform one test for every excavation.
SMYS	Instrument Indentation Test (IIT)		See Note 8.4, Item 1.a.



Procedure for the Resolution of Unknown Pipeline Features (PRUPF)

Desired Property	Method	Description	Investigation Frequency
Metal Composition	Alloy Analysis	An analysis of pipe metal scrapings chemical composition to determine pipe weldability and manufacturing information.	If this technique is conducted, then collect and forward sample scrapings for future test to ATS.
Long Seam Weld Type	Radiography	Radiographic examination of weld.	If test is desired, it will be specified in dig location package. For pipe that is non-seamless, use radiographic long seam welds to differentiate between SSAW and DSAW. Complete ATS datasheet for radiographic testing (RT) characterization of DSAW and SSAW. Revise datasheet to include assessment of weld quality.
	Visual Inspection	Visual examination of long seam weld.	Clean external long seams then visually inspect and photograph them. Record information in <u>H-Form</u> .
Girth Weld Type	Visual	Visual examination of girth weld.	Clean external pipe weld area, photograph it, and use historical data and visual inspection to identify girth weld type. Record whether SMAW pipe, GMAW pipe, etc. was used, or if it could be a SAW that was rolled in the mill, etc.



Procedure for the Resolution of Unknown Pipeline Features (PRUPF)

8 PROCESS EVOLUTION

- 8.1 This section contains information for those who are responsible for continue development of the PRUPF.
- 8.2 Continue to improve the process to address unknown specifications of features in Company's pipelines.
- 8.3 Adhere to standard methods of tracing, verifying, and completing records.
- 8.4 Continue development the PODS GIS during MAOP validation process to explore and identify pipeline feature specifications that are not included in the respective job files. This includes data from:
1. Job records research effort
 2. Data obtained from field verification activities
 3. Construction, testing, and other investigation performed in the system
- 8.5 This database contains the following:
- Year purchased
 - Year installed
 - Diameter, longitudinal seam type, SMYS and WT
 - Feature specifications that were initially unknown
 - Field investigation results
- 8.6 Correlate database with values contained in this PRUPF to provide additional supporting information regarding specifications such as SMYS and WT. Revise minimum specifications in this PRUPF as appropriate based on new data encountered.
- 8.7 Continue to improve knowledge of purchasing, design/construction practices, and manufacturing methods to provide additional support information for specifications such as SMYS and WT.
- 8.8 Update this procedure to incorporate results of technical studies.



[ = CAUTION or  = WARNING]



END of Instructions



Procedure for the Resolution of Unknown Pipeline Features (PRUPF)

Definitions

Daylighting: Excavating to expose pipe for visual inspection.

Implementation Responsibilities

1 Implementation Plan

- 1.1 The contents of this document applied to transmission pipeline segments during the MAOP validation process and used in engineering analysis by Gas Engineering and Operations.
- 1.2 Some of the assumed values in this standard differ from the previously established values (e.g., used in GIS or Integrity Management), so PG&E (Company) will systematically convert other aspects of its operation to the pipe specification assumptions contained in this document through the course of the MAOP data validation.

2 Quality Control Process

- 2.1 When specification assumptions are chosen as a result of processes described throughout this procedure, Company engineers or engineering leadership must decide whether a review of the use of the assumption is to be conducted, and if so, whether by technical peer or subject matter experts (SME). If such reviews are conducted, they should include:
 1. A review of the results
 2. A review of the processes employed for each assumption to confirm consistency with this procedure
 3. Confirmation that the results are appropriate
 4. A documentation review of the use of assumption, if documentation is appropriate
- 2.2 Use quality control effort not only to improve the quality of specifications assumed in this procedure, but also to improve accuracy of the content of this procedure. Provide exceptions or changes to be considered to owner of this procedure.

3 Documentation Process

- 3.1 Company personnel who use assumptions from this procedure must document the use of assumed values from this procedure, and any technical review which may have been conducted.
 - 3.2 General gas engineering application – Engineers who adopt specification assumptions from this procedure must document the use of assumptions including any technical peer or SME review that may have
-



Procedure for the Resolution of Unknown Pipeline Features (PRUPF)

been performed to concur.

- 3.3 Organizations separate from MAOP Validation (e.g., Pipeline Engineering and Transmission Integrity Management) are responsible for completing and submitting a one-line pipeline features list (PFL) to MAOP Validation for inclusion in the pipeline system database, Intrepid.

4 Change Management Process

- 4.1 When changes are made to a specification value in this procedure, equipment evaluated with all previous versions of the value needs to be reassessed with the new value. Accomplish this task with the new Geographical Information Systems (GIS) automated processes, or with data entry that captures the use of an assumption in this procedure, so that when assumption changes occur, the instances where assumptions were used can be reassessed. Such changes should be logged in detail of this procedure’s revision notes.

5 MAOP Validation Process

- 5.1 MAOP validation process must flag specifications in a PFL that are the results of assumed values and processes in this procedure. This is to ensure that future users of the data know that such specifications are assumed.

6 Continued Development Process

- 6.1 User input is critical to continued development. User input is to be provided to the owner of this procedure.

Governing Document

Utility Procedure: TD-4125S, 6/1/13, Requirements for Establishing, Revising, and Documenting MAOPs of Pipelines

Compliance Requirement/Regulatory Commitment

California Public Utilities Commission (CPUC) San Bruno incident Resolution L-410 and Rulemaking (R.) 11-02-019 directive required Company to review “traceable, verifiable, and complete as-built drawings and pipeline system components and, based on the reliable pipeline specifications, calculate the maximum allowable operating pressure (MAOP).”

Reference Documents

Developmental References:



Procedure for the Resolution of Unknown Pipeline Features (PRUPF)

Title 49 – Code of Federal Regulations

Subpart A – General

Class locations..... §192.5

What documents are incorporated by reference partly or wholly in this part? §192.7

How are onshore gathering lines and regulated onshore gathering lines determined? §192.8

Subpart B – Materials

Steel pipe..... §192.55

Transportation of pipe §192.65

Subpart E – Welding of Steel in Pipelines

Nondestructive testing..... §192.243

Subpart J – Test Requirements

General Requirements..... §192.503

Operating at a Hoop Stress of 30 Percent or More of SMYS..... §192.505

Operating at a hoop stress less than 30 percent of SMYS and at or above 100 psi.. §192.507

Test requirements for pipelines to operate below 100 psi (689 kpa) gage..... §192.509

Test requirements for service lines..... §192.511

Environmental protection and safety requirements..... §192.515

Records..... §192.517

Subpart L – Operations

General provisions..... §192.603

Procedural manual for operations, maintenance, and emergencies..... §192.605

Subpart O – Gas Transmission Pipeline Integrity Management



Procedure for the Resolution of Unknown Pipeline Features (PRUPF)

Potential threat identification.....§192.917

Company Documents

“Butt Weld Pipe Pressure Limits” PG&E, June 18, 2012

Other Publications

1944 Book of A.S.T.M. Standards, ASTM (ASTM, Philadelphia 1945)

"Appropriate MAOP for Pipe Constructed with Belled Joints," Kiefner & Assoc Inc., Worthington, OH August 2, 2011

"Final Report – Evaluation of Pressure Limits for Furnace Butt Welded Line Pipe" Kiefner & Assoc Inc., Worthington, OH June 8, 2012

"Joint Factors for Seam Welded Pipe Bends," Kiefner & Assoc Inc., Worthington, OH August 20, 2011 (draft)

"Pipe Wall Thickness Transition Weld Details and MAOP," Kiefner & Assoc Inc., Worthington, OH August 2, 2011

Supplemental References:

Title 49 – Code of Federal Regulations

Subpart C – Pipe Design

Design formula for steel pipe..... §192.105

Yield strength (S) for steel pipe..... §192.107

Nominal wall thickness (t) for steel pipe..... §192.109

Design factor for steel pipe..... §192.111

Longitudinal joint factor (E) for steel pipe..... §192.113

Subpart L – Operations

Maximum allowable operating pressure:
Steel or plastic pipelines..... §192.619

Appendix B

Qualification of pipe..... 49 CFR Part 192 Appendix B



Procedure for the Resolution of Unknown Pipeline Features (PRUPF)

Other Codes and Standards

ASME:

- Magnetic particle examination..... ASME Section V Article 7
- Magnetic particle standards..... ASME Article 25 SE 709
- Nondestructive examination (NDE)..... ASME Article 22 SE 94
- Radiographic examination..... ASME Section V Article 2
- CPUC General Order..... No. 112
- Magnetic particle examination..... ASTM Specification E 709-01

Company Documents

086868 Pipeline data sheet – MAOP of lines operating at or above 20% SMYS, Revision 0

1968 CPUC Filing “Initial Report of Pipelines and Mains Operating at or above 20% SMYS” PG&E, March 27, 1969

1974-1975 MAOP Study

Applied Technology Services (ATS):

- ATS-IIT Assessment Summary
- Instrumented Indentation Testing Procedure.....ATS357.MT.05
- Longitudinal weld seam datasheet
- Magnetic particle inspection procedure
- Pipe Seam Type Determination Procedure
- Procedure for radiographic examination of pipe weld
- Validation of DSAW v. SSAW characterization using radiography method
- EMG (Pre-1970 course material)..... EMG
- Identification of steel pipe..... A-11
- Inspection and long seam characterizations..... H-Form
- Gas main welding sleeves



Procedure for the Resolution of Unknown Pipeline Features (PRUPF)

(Type b sleeves with circumferential welds)..... A-60

Gas pipeline pressure limit calculation guide..... MAOP Calc

MAOP Data Validation Project Wall Thickness Tool..... AKM-MAOP-420G

MAOP Validation and Verification (TD-4125P-08)
“Pipeline Records Quality Evaluation”..... Attachment 2

PFL macro enabled worksheet..... Latest version

Procedures for pipe removed for cause..... Standard 7100

“Reference Manual Procedure for Resolution of Unknown Pipeline Features,” PG&E, November 16, 2012 (draft)

Other Publications

API Specification 5L: Specification for Line Pipe, 44th Edition, (API, Washington DC 2008)

ArcMet 900 machine: Arc-Met 930 User's Manual, v2.3 (Metorex International)

Arc-Met 8000 machine: Arc-Met 8000 Mobile Alloy Analyzer and Sorter User Manual, 202 Edition (Oxford Instruments)

Chemical Testing Equipment Manufacturing Instruction Manual

History of Line Pipe Manufacturing in North America, J. F. Kiefner and E. B. Clark (ASME, New York 1996)

“Standard Test Methods for Automated Ball Indentation (ABI) Testing of Metallic Materials and Structures to Determine Tensile Properties and Stress-Strain Curves,” F. M. Haggag, Oak Ridge, TN, 2009

Appendices

- Appendix A, “Determination of Minimum Recommended SMYS Values for Pipe”
- Appendix B, “Commercially Available Pipe Wall Thickness Values”
- Appendix C, “Pipe Minimum Wall 085626 Between 08/29/1972 and 07/27/1990”



Procedure for the Resolution of Unknown Pipeline Features (PRUPF)

Attachments Attachment 1. Standard Practice 1604 (1963)

Document Recision N/A

Approved By [Enter name, title, and department]

Document Owner [List the name and title of the person whose responsibility is to maintain the procedure.]

Document Contact [Enter the name(s) and title(s) of the subject matter or technical expert(s) who can answer questions about the procedure.]

Revision Notes

Where?	What Changed?
[Write the location within the document (i.e., section, step, substep) of change.]	[Include a brief description of any significant change(s) from the previous version of this document. List each change on a separate line.]

Procedure for the Resolution of Unknown Pipeline Features (PRUPF)**APPENDIX A, DETERMINATION OF MINIMUM RECOMMENDED SMYS VALUES FOR PIPE**

Page 1 of 19

1. Use the following information to determine minimum recommended SMYS values:
 - a Use seam type and nominal pipe diameter with information from this appendix to determine the SMYS value for pipe features when SMYS is unknown.
 - b IF unknown specifications are encountered for pipe installed after 08/29/1972, and the specification assumptions from this procedure result in pipe that is not strong enough for MAOP-R,

THEN consider the combinations of minimum SMYS presented in Appendix C, "Pipe Minimum Wall 085626 Between 08/29/1972 and 07/27/1990" as minimums. SME review is recommended.
 - c IF insufficient information is available to determine the seam type based on what is provided for a particular diameter,

THEN choose the lowest SMYS value for that diameter in that time frame.
 - d IF purchase date is unknown,

THEN adjust from the known install date as described in Section 3, "Adjustments for Unknown Company Purchase Date."
 - e IF purchase date, install date, or date ranges are unknown,

THEN use the most conservative seam type and SMYS for pipe diameter.



Procedure for the Resolution of Unknown Pipeline Features (PRUPF)

APPENDIX A, DETERMINATION OF MINIMUM RECOMMENDED SMYS VALUES FOR PIPE

Page 2 of 19

- f When time frames for the ten-year purchase period overlap, examine different data presented in multiple cells of Table 3 (Appendix A) and choose the most conservative ten-year purchase period value.
- g Between 06/14/1962 and 10/12/1964 (plus ten-year installation period equals to 10/11/1974), Company purchased 35 kpsi SMLS pipe—for higher pressure applications, and 28 kpsi SMLS pipe with four inches by 0.156-inch—for distribution system to use for a period after 06/14/1962.
- h IF the four inch pipe at issue could be 0.156-inch SMLS,

THEN 28 kpsi is a possible conservative value instead of 35 kpsi for four inches by 0.156-inch size, and SME review should be conducted to resolve whether to use 28 kpsi or 35 kpsi. See Table 4, “Company-Specific Exceptions” for more information.
- i Company has records of eight inches by 0.203-inch SW pipe installed on 12/21/1945.

IF the eight inch pipe at issue could be 0.203-inch SW,

THEN use it with 24 kpsi SMYS and longitudinal seam factor $E=0.8$. This is the most conservative choice in the time period from the install date up through 12/20/1955. See Table 4 for more information.
- j Company has also found six inches by 0.169-inch SW pipe installed on 06/17/1948.

IF the six inches pipe at issue could be 0.169-inch SW,

THEN use it with 24 kpsi SMYS and longitudinal seam factor $E=0.8$. This is the most conservative choice in the time period from the install date up through 06/16/1958. When encountering pipe of this WT in this time frame, consider whether it could be this spec. See Table 4 for more information.

Procedure for the Resolution of Unknown Pipeline Features (PRUPF)

APPENDIX A, DETERMINATION OF MINIMUM RECOMMENDED SMYS VALUES FOR PIPE

Page 3 of 19

- k A single instance of a short segment of four inches by 0.196 inch LW was found installed in 1948 in DREG 5645. While a possibility exists that other pipe found in this WT could be the same LW pipe, because no other instances of LW have been found in this diameter, this seam type is not adopted as a minimum specification to be employed for four inch pipe. See Table 4 for more information.
 - l While Company has no record of 18 inch LW, because larger diameter pipe has been found in documentation and/or in the field, review with SME for the possibility that 18 inch pipe purchased prior to 12/31/1930 has E=0.8.
2. See Figure 7. Determination of Minimum Recommended SMYS Values Process for more details.
 3. See Table 3 for more information.

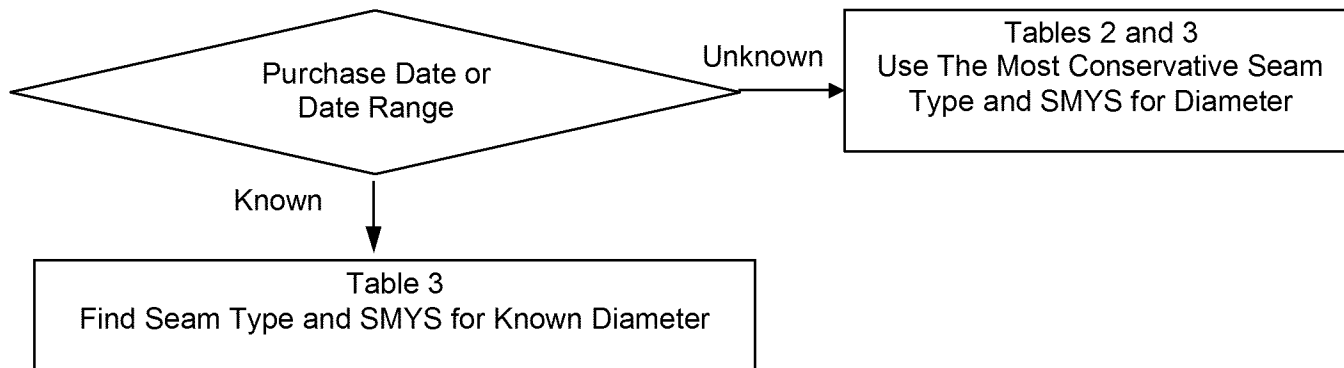

Figure 7. Determination of Minimum Recommended SMYS Values Process

Procedure for the Resolution of Unknown Pipeline Features (PRUPF)**APPENDIX A, DETERMINATION OF MINIMUM RECOMMENDED SMYS VALUES FOR PIPE**

Page 4 of 19

4. Table 3 contains the following seam type abbreviations:
 - AOS = A.O. Smith
 - BW = Butt Weld
 - D or DSAW = Double Submerged Arc Weld
 - E or ERW = Electric Resistance Weld
 - L or LW = Lap Weld
 - S or SMLS = Seamless
 - SSAW = Single Submerged Arc Weld
 - SW = Spiral Weld
5. IF BW pipe is known to have been made to the American Society for Testing and Materials (ASTM) A53,
THEN the minimum of 30 kpsi (Grade A) can be adopted.
6. IF pipe SMYS is known to be greater than 30 kpsi,
THEN BW is disqualified as a suggestion, and SMLS/ERW can be assumed.



Procedure for the Resolution of Unknown Pipeline Features (PRUPF)

APPENDIX A, DETERMINATION OF MINIMUM RECOMMENDED SMYS VALUES FOR PIPE

Page 5 of 19

Table 3. Minimum Recommended SMYS Values for Pipe

Nominal Pipe Size (inches)	Seam Type & Joint Factor	PURCHASE DATE								
		See Section 3 if Purchase Date is Unknown								
		Unknown Date	Prior to 12/31/1930	01/01/1931 to 12/31/1948	01/01/1949 to 01/30/1955	01/31/1955 to 11/23/1959	11/24/1959 to 10/12/1964	10/13/1964 to 05/31/1970	06/01/1970 to present	
MINIMUM SMYS of MATERIAL (kpsi)										
1/4 to 4	Unknown	Note: For unknown seam type in 4" and smaller diameter, use BW from rows immediately below.								
1/4 to 2	BW 0.6	25	28	28	28	28	28	28	28	25
								06/01/1970 to 02/12/1973	As of 02/13/1973	
3	BW 0.6	25	28	28	28	28	28	28	25	N/A
								10/13/1964 to 10/26/1967	As of 10/27/1967	
4	BW 0.6	28	28	28	28	28	28	28	28	N/A



Procedure for the Resolution of Unknown Pipeline Features (PRUPF)

APPENDIX A, DETERMINATION OF MINIMUM RECOMMENDED SMYS VALUES FOR PIPE

Page 6 of 19

Nominal Pipe Size (inches)	Seam Type & Joint Factor	PURCHASE DATE										
		See Section 3 if Purchase Date is Unknown										
		Un-known Date	Prior to 12/31/1930	01/01/1931 to 12/31/1948	01/01/1949 to 01/30/1955	01/31/1955 to 11/23/1959	11/24/1959 to 10/12/1964	10/13/1964 to 08/28/1972	08/29/1972 to 07/27/1990	07/28/1990 to 02/27/1995	02/28/1995 to 10/18/1998	As of 10/19/1998
MINIMUM SMYS of MATERIAL (kpsi)												
All diameter	Not BW	Note: For unknown seam type for which BW has been ruled out, used the most conservative seam type/joint efficiency and SMYS combination from the rows below for the diameter under consideration.										
3/4 to 2	SMLS 1.0	30	30	30	35	30	30	35	35	35	35	35
3	SMLS or ERW 1.0	30	30	30	35	30	30	35	35	35	35	35
4	SMLS or ERW 1.0	30	30	30	35	35	35	35	35	35	35	35



Procedure for the Resolution of Unknown Pipeline Features (PRUPF)

APPENDIX A, DETERMINATION OF MINIMUM RECOMMENDED SMYS VALUES FOR PIPE

Page 7 of 19

Nominal Pipe Size (inches)	Seam Type & Joint Factor	PURCHASE DATE										
		See Section 3 if Purchase Date is Unknown										
		Un-known Date	Prior to 12/31/1930	01/01/1931 to 12/31/1948	01/01/1949 to 01/30/1955	01/31/1955 to 11/23/1959	11/24/1959 to 10/12/1964	10/13/1964 to 08/28/1972	08/29/1972 to 07/27/1990	07/28/1990 to 02/27/1995	02/28/1995 to 10/18/1998	As of 10/19/1998
MINIMUM SMYS of MATERIAL (kpsi)												
4 x 0.196	LW 0.8	N/A	28	If pipe is known 0.196" +/- WT with 1948 purchase data or 1948 to 1958 install date, 28k 0.8 lap weld is possible ⁽¹⁾⁽²⁾ .								
4 x 0.156	SMLS 1.0	N/A				28	If pipe is known 0.156" WT with 06/14/1962 to 10/12/1964 purchase date, or 06/14/1962 to 10/11/1974 install date, 28k SMLS is possible ⁽²⁾⁽³⁾ .					
4 x 0.107	SMLS 1.0	N/A				28	If pipe is known 0.107" WT with 06/14/1962 to 10/12/1964 purchase date, or 06/14/1962 to 10/11/1974 install date, 28k SMLS is possible ⁽²⁾ .					
4 x 0.109	SMLS 1.0	N/A				28	If pipe is known 0.109" WT with 01/01/1930 to 12/31/1930 purchase date, or 01/01/1930 to 12/30/1940 install date, 28k SMLS is possible ⁽⁴⁾ .					

Table notes:

(1): See Appendix A, Notes 1.k.

(2): See Note 4.6, "Exceptions."

(3): See Appendix A, Notes 1.g and 1.h.

(4): See Appendix A, Note 1.l.



Procedure for the Resolution of Unknown Pipeline Features (PRUPF)

APPENDIX A, DETERMINATION OF MINIMUM RECOMMENDED SMYS VALUES FOR PIPE

Page 8 of 19

Nominal Pipe Size (inches)	Seam Type & Joint Factor	PURCHASE DATE										
		See Section 3 if Purchase Date is Unknown										
		Un-known Date	Prior to 12/31/1930	01/01/1931 to 12/31/1948	01/01/1949 to 01/30/1955	01/31/1955 to 11/23/1959	11/24/1959 to 10/12/1964	10/13/1964 to 08/28/1972	08/29/1972 to 07/27/1990	07/28/1990 to 02/27/1995	02/28/1995 to 10/18/1998	As of 10/19/1998
MINIMUM SMYS of MATERIAL (kpsi)												
6	Un-known	28 L		30 S/E	35 SMLS/ERW							
	LW 0.8	28	28	N/A								
	SMLS 1.0	30	30	30	35	35	35	35	35	35	35	35
	ERW 1.0	30	30	30	35	42	42	35	42	42	42	35
6 x 0.169	SW 0.8	N/A		24	If pipe is known 0.169" WT with 06/17/1948 purchase date, or 06/17/1948 to 06/16/1958 install date, 24k spiral weld is possible ⁽²⁾⁽⁵⁾ .							

Table notes:

(2): See Note 4.6, "Exceptions."

(5): See Appendix A, Note 1.j.



Procedure for the Resolution of Unknown Pipeline Features (PRUPF)

APPENDIX A, DETERMINATION OF MINIMUM RECOMMENDED SMYS VALUES FOR PIPE

Page 9 of 19

Nominal Pipe Size (inches)	Seam Type & Joint Factor	PURCHASE DATE										
		See Section 3 if Purchase Date is Unknown										
		Un-known Date	Prior to 12/31/1930	01/01/1931 to 12/31/1948	01/01/1949 to 01/30/1955	01/31/1955 to 11/23/1959	11/24/1959 to 10/12/1964	10/13/1964 to 08/28/1972	08/29/1972 to 07/27/1990	07/28/1990 to 02/27/1995	02/28/1995 to 10/18/1998	As of 10/19/1998
MINIMUM SMYS of MATERIAL (kpsi)												
8	Un-known	28 L		30 S/E	35 SMLS/ERW							
	LW 0.8	28	28	N/A								
	SMLS 1.0	30	30	30	35	35	35	35	35	35	35	35
	ERW 1.0	30	30	30	35	42	42	35	42	42	42	35
8 x 0.203	SW 0.8	N/A		24	If pipe is known 0.203" WT with 12/21/1945 purchase date, or 12/21/1945 to 12/20/1955 install date, 24k spiral weld is possible ⁽⁴⁾⁽⁶⁾ .							
8 x 0.322	LW 0.8	N/A		35	If pipe is known 0.322" WT with 08/21/1942 or earlier install date, 35k lap weld is possible ⁽²⁾⁽⁶⁾ .							

Table notes:

(2): See Note 4.6, "Exceptions."

(4): See Appendix A, Note 1.i.

(6): See Appendix A, Note 1.i



Procedure for the Resolution of Unknown Pipeline Features (PRUPF)

APPENDIX A, DETERMINATION OF MINIMUM RECOMMENDED SMYS VALUES FOR PIPE

Page 10 of 19

Nominal Pipe Size (inches)	Seam Type & Joint Factor	PURCHASE DATE										
		See Section 3 if Purchase Date is Unknown										
		Un-known Date	Prior to 12/31/1930	01/01/1931 to 12/31/1948	01/01/1949 to 01/30/1955	01/31/1955 to 11/23/1959	11/24/1959 to 10/12/1964	10/13/1964 to 08/28/1972	08/29/1972 to 07/27/1990	07/28/1990 to 02/27/1995	02/28/1995 to 10/18/1998	As of 10/19/1998
MINIMUM SMYS of MATERIAL (kpsi)												
10	Un-known	28 L		30 S/E	35 SMLS/ERW							
	LW 0.8	28	28	N/A								
	SMLS 1.0	30	30	30	35	35	35	35	35	35	35	35
	ERW 1.0	30	30	30	35	42	42	35	35	35	35	35



Procedure for the Resolution of Unknown Pipeline Features (PRUPF)

APPENDIX A, DETERMINATION OF MINIMUM RECOMMENDED SMYS VALUES FOR PIPE

Page 11 of 19

Nominal Pipe Size (inches)	Seam Type & Joint Factor	PURCHASE DATE										
		See Section 3 if Purchase Date is Unknown										
		Un-known Date	Prior to 12/31/1930	01/01/1931 to 12/31/1948	01/01/1949 to 01/30/1955	01/31/1955 to 11/23/1959	11/24/1959 to 10/12/1964	10/13/1964 to 08/28/1972	08/29/1972 to 07/27/1990	07/28/1990 to 02/27/1995	02/28/1995 to 10/18/1998	As of 10/19/1998
MINIMUM SMYS of MATERIAL (kpsi)												
12	Un-known	28 L		30 S/E	35 SMLS/ERW							
	LW 0.8	28	28	N/A								
	AOS 0.8	33	33	N/A								
	SMLS 1.0	30	30	30	35	35	35	35	35	35	35	35
	ERW 1.0	30	30	30	35	35	42	35	35	35	35	35
12 x 0.203"	AOS 0.8	N/A		33	If pipe is known 0.203" WT with 08/07/1941 purchase date, or 08/07/1941 – 08/06/1951 install date, 33k A. O. Smith is possible ⁽²⁾ .							

Table note:

(2): See Note 4.6, "Exceptions."



Procedure for the Resolution of Unknown Pipeline Features (PRUPF)

APPENDIX A, DETERMINATION OF MINIMUM RECOMMENDED SMYS VALUES FOR PIPE

Page 12 of 19

Nominal Pipe Size (inches)	Seam Type & Joint Factor	PURCHASE DATE										
		See Section 3 if Purchase Date is Unknown										
		Un-known Date	Prior to 12/31/1930	01/01/1931 to 12/31/1948	01/01/1949 to 01/30/1955	01/31/1955 to 11/23/1959	11/24/1959 to 10/12/1964	10/13/1964 to 08/28/1972	08/29/1972 to 07/27/1990	07/28/1990 to 02/27/1995	02/28/1995 to 10/18/1998	As of 10/19/1998
		MINIMUM SMYS of MATERIAL (kpsi)										
14	Un-known	30 S/E				35 SMLS/ERW						
	SMLS 1.0	30	30	30	35	35	35	35	35	35	35	35
	ERW 1.0	30	30	30	35	42	42	35	35	35	35	35



Procedure for the Resolution of Unknown Pipeline Features (PRUPF)

APPENDIX A, DETERMINATION OF MINIMUM RECOMMENDED SMYS VALUES FOR PIPE

Page 13 of 19

Nominal Pipe Size (inches)	Seam Type & Joint Factor	PURCHASE DATE										
		See Section 3 if Purchase Date is Unknown										
		Un-known Date	Prior to 12/31/1930	01/01/1931 to 12/31/1948	01/01/1949 to 01/30/1955	01/31/1955 to 11/23/1959	11/24/1959 to 10/12/1964	10/13/1964 to 08/28/1972	08/29/1972 to 07/27/1990	07/28/1990 to 02/27/1995	02/28/1995 to 10/18/1998	As of 10/19/1998
MINIMUM SMYS of MATERIAL (kpsi)												
16	Un-known	33 AOS			35 SMLS/ERW							
	AOS 0.8	33	33	33	N/A							
	SMLS 1.0	30	30	30	35	35	35	35	35	35	35	35
	ERW 1.0	30	30	30	35	42	42	35	35	35	35	35
16 x 0.281	SSAW 0.8	N/A			42	If pipe is known 0.281" WT with 01/01/1953 to 12/31/1954 purchase date, or 01/01/1953 to 12/30/1964 install date, 42k SSAW is possible ⁽²⁾ .						

Table note:

(2): See Note 4.6, "Exceptions."



Procedure for the Resolution of Unknown Pipeline Features (PRUPF)

APPENDIX A, DETERMINATION OF MINIMUM RECOMMENDED SMYS VALUES FOR PIPE

Page 14 of 19

Nominal Pipe Size (inches)	Seam Type & Joint Factor	PURCHASE DATE										
		See Section 3 if Purchase Date is Unknown										
		Un-known Date	Prior to 12/31/1930	01/01/1931 to 12/31/1948	01/01/1949 to 01/30/1955	01/31/1955 to 11/23/1959	11/24/1959 to 10/12/1964	10/13/1964 to 08/28/1972	08/29/1972 to 07/27/1990	07/28/1990 to 02/27/1995	02/28/1995 to 10/18/1998	As of 10/19/1998
		MINIMUM SMYS of MATERIAL (kpsi)										
18	Un-known	30 SMLS/ERW/DSAW ⁽⁷⁾			35 SMLS/ERW/DSAW				42 SMLS/ERW/DSAW			35 S/E/D
	SMLS 1.0	30	30	30	35	35	35	35	42	42	42	35
	ERW 1.0	30	30	30	35	42	35	35	42	42	42	35
	DSAW 1.0	35	35	35	35	35	35	35	35	42	42	42

Table note:

(7): See Note 4.3.Items 5j



Procedure for the Resolution of Unknown Pipeline Features (PRUPF)

APPENDIX A, DETERMINATION OF MINIMUM RECOMMENDED SMYS VALUES FOR PIPE

Page 15 of 19

Nominal Pipe Size (inches)	Seam Type & Joint Factor	PURCHASE DATE										
		See Section 3 if Purchase Date is Unknown										
		Un-known Date	Prior to 12/31/1930	01/01/1931 to 12/31/1948	01/01/1949 to 01/30/1955	01/31/1955 to 11/23/1959	11/24/1959 to 10/12/1964	10/13/1964 to 08/28/1972	08/29/1972 to 07/27/1990	07/28/1990 to 02/27/1995	02/28/1995 to 10/18/1998	As of 10/19/1998
		MINIMUM SMYS of MATERIAL (kpsi)										
20	Un-known	33 SSAW/AOS			35 SMLS/DSAW				42 SMLS/DSAW			35 S/D
	SSAW / AOS 0.8	33	33	33	N/A							
	SMLS	30	30	30	35	35	35	35	42	42	42	35
	DSAW 1.0	35	35	35	35	42	35	35	42	42	42	42



Procedure for the Resolution of Unknown Pipeline Features (PRUPF)

APPENDIX A, DETERMINATION OF MINIMUM RECOMMENDED SMYS VALUES FOR PIPE

Page 16 of 19

Nominal Pipe Size (inches)	Seam Type & Joint Factor	PURCHASE DATE										
		See Section 3 if Purchase Date is Unknown										
		Un-known Date	Prior to 12/31/1930	01/01/1931 to 12/31/1948	01/01/1949 to 01/30/1955	01/31/1955 to 11/23/1959	11/24/1959 to 10/12/1964	10/13/1964 to 08/28/1972	08/29/1972 to 07/27/1990	07/28/1990 to 02/27/1995	02/28/1995 to 10/18/1998	As of 10/19/1998
		MINIMUM SMYS of MATERIAL (kpsi)										
22	Un-known	33 SSAW/AOS			35 SMLS/DSAW				42 SMLS/DSAW			35 S/D
	SSAW / AOS 0.8	33	33	33	N/A							
	SMLS 1.0	30	30	30	35	35	35	35	42	42	42	35
	DSAW 1.0	35	35	35	35	42	35	35	35	35	42	35



Procedure for the Resolution of Unknown Pipeline Features (PRUPF)

APPENDIX A, DETERMINATION OF MINIMUM RECOMMENDED SMYS VALUES FOR PIPE

Page 17 of 19

Nominal Pipe Size (inches)	Seam Type & Joint Factor	PURCHASE DATE										
		See Section 3 if Purchase Date is Unknown										
		Un-known Date	Prior to 12/31/1930	01/01/1931 to 12/31/1948	01/01/1949 to 01/30/1955	01/31/1955 to 11/23/1959	11/24/1959 to 10/12/1964	10/13/1964 to 08/28/1972	08/29/1972 to 07/27/1990	07/28/1990 to 02/27/1995	02/28/1995 to 10/18/1998	As of 10/19/1998
		MINIMUM SMYS of MATERIAL (kpsi)										
24	Un-known	33 SSAW/AOS			35 SMLS/DSAW						42 S/D	35 S/D
	SSAW / AOS 0.8	33	33	33	N/A							
	SMLS 1.0	30	30	30	35	35	35	35	35	35	42	35
	DSAW 1.0	35	35	35	35	42	35	35	42	42	42	42



Procedure for the Resolution of Unknown Pipeline Features (PRUPF)

APPENDIX A, DETERMINATION OF MINIMUM RECOMMENDED SMYS VALUES FOR PIPE

Page 18 of 19

Nominal Pipe Size (inches)	Seam Type & Joint Factor	PURCHASE DATE										
		See Section 3 if Purchase Date is Unknown										
		Un-known Date	Prior to 12/31/1930	01/01/1931 to 12/31/1948	01/01/1949 to 01/30/1955	01/31/1955 to 11/23/1959	11/24/1959 to 10/12/1964	10/13/1964 to 08/28/1972	08/29/1972 to 07/27/1990	07/28/1990 to 02/27/1995	02/28/1995 to 10/18/1998	As of 10/19/1998
MINIMUM SMYS of MATERIAL (kpsi)												
26	Un-known	33 SSAW/AOS			35 DSAW				42 DSAW			
	SSAW / AOS 0.8	33	33	33	N/A							
	DSAW 1.0	35	35	35	35	35	35	35	42	42	42	42
30	DSAW 1.0	35	35	35	35	35	35	35	52	42	42	42



Procedure for the Resolution of Unknown Pipeline Features (PRUPF)

APPENDIX A, DETERMINATION OF MINIMUM RECOMMENDED SMYS VALUES FOR PIPE

Page 19 of 19

Nominal Pipe Size (inches)	Seam Type & Joint Factor	PURCHASE DATE See Section 3 if Purchase Date is Unknown										
		Un-known Date	Prior to 12/31/1930	01/01/1931 to 12/31/1948	01/01/1949 to 01/30/1955	01/31/1955 to 11/23/1959	11/24/1959 to 10/12/1964	10/13/1964 to 08/28/1972	08/29/1972 to 07/27/1990	07/28/1990 to 02/27/1995	02/28/1995 to 10/18/1998	As of 10/19/1998
MINIMUM SMYS of MATERIAL (kpsi)												
32	DSAW 1.0	35	35	35	35	35	35	35	60	42	42	42
34	DSAW 1.0	35	35	35	35	35	35	42	65	42	42	42
36, 40, 42	DSAW 1.0	35	35	35	35	35	35	42	60	42	42	42



Procedure for the Resolution of Unknown Pipeline Features (PRUPF)

APPENDIX B, COMMERCIALY AVAILABLE PIPE WALL THICKNESS VALUES

Page 1 of 4

Nominal OD	½"	¾"	1"	1 ½"	1 ¾"	2"	3"	4"	6"	8"	10"	12"	14"	16"
Actual OD	0.84	1.05	1.315	1.66	1.9	2.375	3.5	4.5	6.625	8.625	10.75	12.75	14	16
WT Choices	0.147	0.083	0.065	0.065	0.065	0.065	0.083	0.083	0.109	0.109	0.134	0.156	0.156	0.165
	0.179	0.113	0.109	0.109	0.109	0.109	0.120	0.120	0.134	0.148	0.165	0.180	0.188	0.188
		0.133	0.133	0.140	0.145	0.154	0.141	0.141	0.140	0.172	0.188	0.203	0.210	0.219
		0.154	0.179	0.191	0.188	0.216	0.148	0.148	0.156	0.188	0.203	0.219	0.219	0.250
		0.179	0.250	0.250	0.200	0.218	0.156	0.156	0.168	0.203	0.219	0.250	0.250	0.281
		0.218	0.358	0.382	0.281	0.219	0.188	0.188	0.172	0.216	0.220	0.259	0.281	0.312
		0.308			0.400	0.237	0.216	0.237	0.188	0.217	0.250	0.281	0.312	0.313
		0.650			0.525	0.343	0.300	0.250	0.219	0.219	0.259	0.312	0.344	0.375
					0.650	0.436	0.437	0.334	0.237	0.220	0.271	0.313	0.375	0.401
						0.562	0.600	0.337	0.250	0.250	0.281	0.322	0.437	0.438
						0.687	0.725	0.370	0.277	0.277	0.300	0.330	0.469	0.500
							0.850	0.437	0.280	0.281	0.307	0.340	0.500	0.520
								0.500	0.432	0.322	0.322	0.375	0.593	0.656
								0.531	0.500	0.338	0.344	0.406	0.625	0.680



Procedure for the Resolution of Unknown Pipeline Features (PRUPF)

APPENDIX B, COMMERCIALY AVAILABLE PIPE WALL THICKNESS VALUES

Page 2 of 4

Nominal OD	1/2"	3/4"	1"	1 1/2"	1 3/4"	2"	3"	4"	6"	8"	10"	12"	14"	16"
Actual OD	0.84	1.05	1.315	1.66	1.9	2.375	3.5	4.5	6.625	8.625	10.75	12.75	14	16
WT Choices								0.674	0.562	0.406	0.365	0.438	0.750	0.843
								0.800	0.718	0.500	0.375	0.483	0.937	0.844
								0.925	0.864	0.593	0.438	0.500	1.093	1.031
									1.000	0.594	0.500	0.520	1.250	1.218
									1.125	0.718	0.593	0.562	1.406	1.437
										0.812	0.594	0.625		1.593
										0.875	0.718	0.687		
										0.906	0.843	0.750		
										1.000	0.875	0.843		
										1.125	1.000	0.844		
											1.125	1.000		
											1.250	1.125		
											1.500	1.250		
											1.312			



Procedure for the Resolution of Unknown Pipeline Features (PRUPF)

APPENDIX B, COMMERCIALY AVAILABLE PIPE WALL THICKNESS VALUES

Page 3 of 4

Nominal OD	18"	20"	22"	24"	26"	28"	30"	32"	34"	34 ½"	36"	40"	42"
Actual OD	18	20	22	24	26	28	30	32	34	35	36	40	42
WT Choices	0.165	0.188	0.188	0.218	0.250	0.250	0.250	0.250	0.250	0.375	0.250	0.438	0.375
	0.188	0.218	0.218	0.250	0.281	0.312	0.281	0.281	0.281	0.438	0.281	0.500	0.406
	0.250	0.219	0.250	0.271	0.295	0.375	0.290	0.312	0.312	0.469	0.312	0.250	0.407
	0.281	0.250	0.281	0.281	0.297	0.500	0.312	0.344	0.313	0.500	0.344	0.375	0.409
	0.312	0.281	0.286	0.312	0.312	0.625	0.313	0.375	0.344	0.750	0.360	0.406	0.434
	0.375	0.312	0.312	0.313	0.313	0.750	0.325	0.406	0.375		0.372	0.407	0.438
	0.437	0.313	0.313	0.344	0.322	0.875	0.344	0.438	0.406		0.375	0.409	0.456
	0.500	0.344	0.344	0.375	0.344	1.000	0.375	0.469	0.438		0.380	0.434	0.469
	0.520	0.375	0.375	0.406	0.375	1.125	0.406	0.500	0.469		0.406	0.438	0.489
	0.562	0.406	0.406	0.438	0.406		0.424	0.625	0.500		0.414	0.456	0.500
	0.750	0.433	0.438	0.469	0.438		0.438	0.688	0.505		0.432	0.469	0.521
	0.937	0.438	0.469	0.500	0.469		0.469	0.750	0.524		0.438	0.489	0.547
	1.156	0.469	0.500	0.562	0.500		0.500	0.875	0.540		0.446	0.500	0.562
1.375	0.500	0.660	0.563	0.625		0.562	1.000	0.562		0.456	0.521	0.586	



Procedure for the Resolution of Unknown Pipeline Features (PRUPF)

APPENDIX B, COMMERCIALY AVAILABLE PIPE WALL THICKNESS VALUES

Page 4 of 4

Nominal OD	18"	20"	22"	24"	26"	28"	30"	32"	34"	34 1/2"	36"	40"	42"
Actual OD	18	20	22	24	26	28	30	32	34	35	36	40	42
WT Choices	1.562	0.593	0.750	0.625	0.750		0.563	1.125	0.625		0.469	0.547	0.625
	1.781	0.750	0.792	0.687	0.875		0.625		0.628		0.500	0.547	0.750
		0.812	0.875	0.688	1.000		0.750		0.688		0.531	0.562	1.000
		0.875	1.000	0.750	1.125		0.813		0.750		0.535	0.586	1.125
		1.031	1.125	0.875			0.875		0.754		0.540	0.625	1.500
		1.281	1.375	0.968			1.000		0.875		0.547	0.750	
		1.500	1.625	1.000			1.125		1.000		0.562	1.000	
		1.750	1.875	1.125					1.125		0.563	1.125	
		1.968	2.125	1.218							0.576	1.500	
				1.531							0.625		
				1.812							0.687		
				2.062							0.688		
				2.343							0.750		
											0.875		
											1.000		
											1.125		



Procedure for the Resolution of Unknown Pipeline Features (PRUPF)

APPENDIX C, PIPE MINIMUM WALL 085626 BETWEEN 08/29/1972 AND 07/27/1990
Page 1 of 1

A-34

**APPENDIX "G"
PLAIN END PIPE
MINIMUM WALL THICKNESS**

DO NOT USE

NOMINAL PIPE SIZE (INCHES)	OUTSIDE DIAMETER (INCHES)	MINIMUM WALL THICKNESS AND GRADE OF MATERIAL	
		PIPELINE (INCHES)	FABRICATED ASSEMBLIES/COMPRESSOR STATIONS (INCHES)
3/4	1.050	-	.113/.154 (GR. B)
1	1.315	-	.113/.179 (GR. B)
1-1/4	1.660	-	.140/.191 (GR. B)
2	2.375	.154 (GR. B)	.154/.218 (GR. B)
3	3.5	.156 (GR. B)	.216 (GR. B)
4	4.5	.156 (GR. B)	.237 (GR. B)
6	6.625	.156 (X-42)	.280 (GR. B)
8	8.625	.172 (X-42)	.322 (GR. B)
10	10.750	.219 (GR. B)	.365 (GR. B)
12	12.750	.219 (GR. B)	.375 (GR. B)
14	14.0	.219 (GR. B)	.375 (GR. B)
16	16.0	.250 (GR. B)	.375 (GR. B)
18	18.0	.250 (X-42)	.375 (GR. B)
20	20.0	.250 (X-42)	.375 (GR. B)
22	22.0	.250 (X-42)	.375 (GR. B)
24	24.0	.250 (X-42)	.375 (GR. B)
26	26.0	.281 (X-42)	.375 (GR. B)
30	30.0	.375 (X-52)	.375 (GR. B)
32	32.0	.375 (X-60)	.375 (GR. B)
34	34.0	.375 (X-65)	.375 (GR. B)
36	36.0	.406 (X-60)	.500 (GR. B)
40	40.0	.438 (X-60)	.500 (GR. B)
42	42.0	.469 (X-60)	.500 (GR. B)

NOTES:

1. THE MINIMUM WALL THICKNESS AND GRADE OF MATERIAL LISTED IN THE PIPELINE COLUMN ARE BASED ON NORMAL MATERIAL AVAILABILITY AND THE MINIMUM STRENGTH NECESSARY TO ACCOMMODATE OVERBURDEN STRESSES.
2. FOR FABRICATED ASSEMBLIES/COMPRESSOR STATIONS (ABOVE GROUND PIPING), THE MINIMUM GRADE B MATERIAL WITH STANDARD OR EXTRA STRONG WALL THICKNESS IS BASED ON COMPATIBILITY WITH STANDARD AND EXTRA HEAVY WALL FITTINGS. EXTRA STRONG PIPE SHOULD BE USED FOR ALL SCREWED CONNECTIONS THROUGH 2 INCHES NOMINAL DIAMETER.
EXTRA STRONG PIPE THROUGH 2 INCHES NOMINAL DIAMETER IS RECOMMENDED FOR COMPRESSOR STATIONS BECAUSE OF THE POTENTIAL FATIGUE PROBLEMS DUE TO VIBRATION.
ALL THE ABOVE PIPE IS ADEQUATE FOR A 16,000 LB. WHEEL LOAD WITH A MINIMUM COVER OF 36 INCHES.

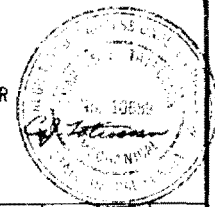

CADD 820363 12/21/82

APPROVED BY									
LWH	PAL	3	7-27-90	DELETED PAGE No. 2	ADDED "DO NOT USE" NOTE				
		2	11-20-85	REVISED PAGE No.		JRC	ATG	BFO	WCK
JAF		1	11-20-83	REVISED TABLE AND NOTES			KA43		
CJT	REV		DATE	DESCRIPTION		GM	DWN	CHKD	SUPV
GM	SUPV						B/M		
DSGN							DWG LIST		
DWG	CADD/ST						SUPSDS		
CHKD	MC						SUPSD BY		
OK	SDJ						SHEET NO	1	OF
DATE	SCALE						DRAWING NUMBER		REV
8-29-72	NONE						085626		3
							MICROFILM		

PIPING-DATA SHEET
MINIMUM PIPE WALL THICKNESS
GAS STANDARD
PACIFIC GAS AND ELECTRIC COMPANY
SAN FRANCISCO, CAL.

51804