



Frances Yee  
Acting Director  
Regulatory Compliance & Support  
Gas Operations

375 N. Wiget Lane, Suite 200  
Walnut Creek, CA 94598

925-974-4316  
Fax: 925-974-4102  
Internet: FSC2@pge.com

July 18, 2013

Mr. Mike Robertson  
Gas Safety and Reliability Branch  
Safety and Enforcement Division  
California Public Utilities Commission  
320 West 4<sup>th</sup> Street, Suite 500  
Los Angeles, CA. 90013

Re: State of California – Public Utilities Commission  
General Order 112-E Audit – PG&E’s General Construction, Welding and Plastic Joining

Dear Mr. Robertson:

The Safety and Enforcement Division (SED), Gas Safety and Reliability Branch (GSRB) of the CPUC conducted a General Order 112-E audit of PG&E’s General Construction, Welding and Plastic Joining Program, from December 4-6, 2012. On June 14, 2013, the SED submitted their audit report, identifying areas of concern and recommendations. Attached is PG&E’s response to the CPUC audit report.

PG&E is providing this response pursuant to Public Utilities Code §583 because this response and/or the attached documents contain information that should remain confidential and not be subject to public disclosure as it contains one or more of the following: critical infrastructure information that is not normally provided to the general public, the dissemination of which poses public safety risks (pursuant to the Critical Infrastructures Information Act of 2002, 6 U.S.C. §§131-134); personal information pertaining to PG&E employees below director level; customer information; or commercially sensitive/proprietary information.

Please contact  at  or  for any questions you may have regarding this response.

Sincerely,

/S/

Frances Yee

**General Order 112-E Findings  
CPUC Inspection Report, dated June 14, 2013  
General Construction, Welding, and Plastic Joining**

Attachments

cc: Aimee Cauquiran, CPUC  
Liza Malashenko, CPUC  
Dennis Lee, CPUC  
Sunil Shori, CPUC

Jane Yura, PG&E  
Redacted PG&E  
Redacted PG&E  
Redacted PG&E

Definitions:      NOV – Notice of Violation  
                          AOC – Area of Concern  
                          AIR – Additional Information Requested

**General Order 112-E Findings  
CPUC Inspection Report, dated June 14, 2013  
General Construction, Welding, and Plastic Joining**

**INSPECTION INFORMATION**

Inspection Dates	Finding	CPUC Contact	CPUC Phone #
December 4-6, 2012	AOC-1	Aimee Cauguiran	(415) 703-2055

**INSPECTION FINDING**

CPUC Finding	<p><b><u>A. Areas of Concern</u></b></p> <p><b>1. Arc Welder Qualification Standard and Records for Working on Pipelines that Operate at over 20% of SMYS</b></p> <p>SED evaluated PG&amp;E’s Arc Welder Qualification Standard for working on pipelines that operate at over 20% of Specified Minimum Yield Strength (SMYS), D-30.2 (Arc Welder Standard, D-30.2) and Arc Welder Qualification test records for piping systems operating at hoop stresses of 20% or more of the SMYS, FD-30.2-A, (Arc Welder qualification test record, FD-30.2-A) and noted the following:</p> <p>PG&amp;E employee, [Redacted] failed two Arc Welder Qualification tests on 11/7/12. His supervisor was notified about the test failure; however, the test form did not show any information regarding the notification.</p> <p>Similarly, PG&amp;E employee, [Redacted] failed the Exx10 Arc Weld qualification test once on 8/20/09 and twice on 10/20/09. [Redacted] passed the test on 11/4/09. There was no email notification sent to his supervisor about the test failures. SED noted that even for an initial qualification test failure, PG&amp;E should have the employee’s supervisor notified of the results.</p> <p>PG&amp;E employee, [Redacted] failed an Arc Welder qualification test on 7/26/12 but passed the test on 7/31/12. SED noted that there should have been a memo on file or some other form of documentation informing his supervisor about the lapse in his qualification so that [Redacted] would not perform Arc welding from the day he failed the test until he was qualified again.</p> <p>Therefore, SED recommends that PG&amp;E do the following improvements and changes to its Arc Welder Standard, D-30.2 and qualification test form, FD-30.2-A:</p> <p style="margin-left: 40px;">a) PG&amp;E needs to inform the employees’ supervisors of any Arc Welder test failures immediately. PG&amp;E should document this either on the Arc Welder qualification test form or on a separate</p>
--------------	---

Definitions:      NOV – Notice of Violation  
                           AOC – Area of Concern  
                           AIR – Additional Information Requested

**General Order 112-E Findings  
CPUC Inspection Report, dated June 14, 2013  
General Construction, Welding, and Plastic Joining**

	<p>form to record the name of the employee, date and type of test, and supervisor’s notification date. Additionally, PG&amp;E should revise its Arc Welder Standard, D-30.2, to describe the process of documenting supervisor notifications.</p> <p>b) If a welder has not performed any qualifications or requalification tests in the past 6 months (lapse in employee’s qualification), PG&amp;E needs to properly document this information and notify the supervisor. Additionally, PG&amp;E’s needs to revise its Arc Welder Standard D-30.2 to describe the process of documenting lapses in an employee’s records.</p> <p>c) Arc Welder Standard, D-30.2, Item 7 of Qualification Test states in part: “The weld shall also be qualified by either the radiographic testing requirements of Numbered Document D-31 (for butt welds only), or the destructive testing requirements of Numbered Document D-31.”</p> <p>PG&amp;E Arc Welder Standard, D-30.2, Item 9 of Requalification Arc Welders states: “A. Welders shall be requalified no later than the last day of the sixth calendar month following the calendar month in which the last previous test was satisfactorily passed. Requalification may consist of successfully passing a radiographic examination of a production butt weld, or by repeating the butt-weld test in Item 7...”</p> <p>SED reviewed Welder Qualification by Radiographic Examination forms and noted that the form does not indicate that it is part of Arc Welder qualifications. PG&amp;E should revise the title of the form to indicate that the form is a record to provide either qualification or requalification for Arc Welders and PG&amp;E should revise its related standards to indicate the type of form to use.</p> <p>d) SED found that some Arc Welder qualification test records do not indicate type of bend tests applied to the specimens. Each specimen subjected to the bend tests should be marked on the form to indicate face, root, or side bends. Also, PG&amp;E’s Standard of Acceptability for Welding: Nondestructive and Destructive Testing, D-31 should describe the criteria for choosing the type of bend tests for the specimen.</p> <p>e) SED also noted that Arc Welder Qualification test form, FD-30.2-A,</p>
--	---

Definitions:      NOV – Notice of Violation  
                           AOC – Area of Concern  
                           AIR – Additional Information Requested

**General Order 112-E Findings  
CPUC Inspection Report, dated June 14, 2013  
General Construction, Welding, and Plastic Joining**

	<p>does not have “Classification” information for the employees tested. PG&amp;E should add this information to the form.</p> <p>f) SED found that PG&amp;E’s welder [Redacted] failed the Arc Welder Qualification test on the following dates: 1/30/12, 3/22/12, 4/24/12, 5/22/12; however, the “Further Training Required” field on the test forms were not filled out. [Redacted] passed the test on 7/30/12. If an employee repeatedly fails a test, PG&amp;E should provide additional training to the employee and the failed test records should indicate that further training is required.</p>
--	--

**PG&E RESPONSE**

PG&E agrees with this area of concern and recently updated its arc welder qualification documents adding a number of improvements and updates.

- Arc Welder Standard D-30.2 is now TD-4160P-31, “Welder Performance Qualification – API 1104 Procedures”
- Arc Welder Qualification test form FD-30.2-A is now TD-4160P-31-F01, “Welder Performance Qualification Record”
- Added new radiographic test form TD-4160P-31-F02, “Welder Performance Record Radiography”

The procedure updates that address the areas of concern include the following:

1a) PG&E added language to procedure TD-4160P-31 (step 10.3) that requires Supervisors be notified of any failure, disqualification, or lapse in qualification. This is to be documented on the respective qualification form TD-4160P-31-F01 or TD-4160P-31-F02.

1b) The recommendation to notify Supervisors of any “lapse in employee qualification” is included in response 1a) above.

1c) PG&E revised procedure TD-4160P-31 (step 10.1) to direct the test administrator to use the respective test form for destructive or radiographic testing. PG&E has updated the title of the radiographic examination form TD-4160P-31-F02, “Welder Performance Record Radiography”

1d) PG&E added a note “(Circle One)” on form TD-4160P-31-F01 to indicate the type of guided bend test performed. Also PG&E has added Appendix 1 to procedure TD-4160P-31 which indicates the type, location, and number of test samples to take from each qualification weld.

1e) PG&E uses a unique identification number (i.e. Personnel Number, Lan-ID, last four digits of the social security number, or assigned stencil number) to identify employees/contractors on the welder performance records. The use of “Classification”

Definitions:      NOV – Notice of Violation  
                           AOC – Area of Concern  
                           AIR – Additional Information Requested

**General Order 112-E Findings  
CPUC Inspection Report, dated June 14, 2013  
General Construction, Welding, and Plastic Joining**

would not correctly identify individuals, as classification can change from each qualification/requalification cycle.

1f) PG&E has added guidelines for retesting to procedure TD-4160P-31 (step 7) that suggest courses of action for retesting if an employee/contractor repeatedly fails a weld qualification test. Every situation has different circumstances so “requiring” further training before retesting is not practicable.

**ATTACHMENTS**

<b>Attachment #</b>	<b>Title or Subject</b>
TD-4160P-31	Welder Performance Qualification – API-1104 Procedures
TD-4160P-31-F01	Welder Performance Record API – Destructive Test
TD-4160P-31-F02	Welder Performance Record - Radiography

**ACTION REQUIRED**

<b>Action To Be Taken</b>	<b>Due Date</b>	<b>Completion Date</b>	<b>Responsible Dept.</b>
NA			

Definitions:      NOV – Notice of Violation  
                           AOC – Area of Concern  
                           AIR – Additional Information Requested

**General Order 112-E Findings  
CPUC Inspection Report, dated June 14, 2013  
General Construction, Welding, and Plastic Joining**

**INSPECTION INFORMATION**

Inspection Dates	Finding	CPUC Contact	CPUC Phone #
December 4-6, 2012	AOC-2	Aimee Cauguiran	(415) 703-2055

**INSPECTION FINDING**

CPUC Finding	<p><b><u>A. Areas of Concern</u></b></p> <p><b>2. Welder Qualifications Standard and Records for Under 20% SMYS</b></p> <p>SED evaluated Welder Qualification Standard, D-30 and Oxyacetylene Weld Test Report for under 20% of SMYS (Oxyacetylene Weld test report), FD-30-B and noted the following:</p> <ul style="list-style-type: none"> <li>a) PG&amp;E Oxyacetylene Weld test report form for welders on piping systems operating at hoop stresses of less than 20% of the specified minimum yield strength (SMYS), FD-30-B, revised 7/08, has a memo-to-file field to be completed if a welder has not performed any qualification tests or verification welding in the past six months. However, PG&amp;E's related Standard, Welder Qualification Standard D-30 does not describe the process or when and how this field will be completed.</li> <li>b) Similarly, PG&amp;E Oxyacetylene Weld test report form FD-30-B has a data field to inform an employee's supervisor of any test failure. However, Standard, D-30 does not describe this notification requirement.</li> </ul> <p>SED determined that PG&amp;E should revise its Standard D-30 to include the procedures to inform supervisors of test failures and fill out a memo when an employee is no longer qualified to perform any type of oxyacetylene welding until the employee successfully passes a destructive test.</p> <p>SED also recommends that PG&amp;E should keep email notifications sent to the supervisors in the employees' qualification folders.</p> <ul style="list-style-type: none"> <li>c) PG&amp;E Oxyacetylene Weld test report form FD-30-B does not indicate if an employee passed or failed as a result of all the destructive tests. Welder qualification and requalification tests, Item 9.C, Test Weld Inspection requirements of Standard D-30</li> </ul>
--------------	---

Definitions:      NOV – Notice of Violation  
                           AOC – Area of Concern  
                           AIR – Additional Information Requested

**General Order 112-E Findings  
CPUC Inspection Report, dated June 14, 2013  
General Construction, Welding, and Plastic Joining**

	<p>states <i>“Four root bend samples are required. Three of the four samples must pass in order for the welder to qualify...”</i></p> <p>It is not clear from the test report if an employee has successfully passed the destructive (root bend, knock off, and appearance) tests. The previous version of this form, 07/05, had two check boxes on top of the form to indicate if an employee passed or failed the tests. These check boxes do not appear on the revised form.</p> <p>SED recommends that form FD-30-B should be revised by adding Pass and Fail boxes to indicate whether or not an employee is qualified to perform welding for under 20% SMYS as a result of series of destructive tests taken.</p>
--	---

**PG&E RESPONSE**

<p>PG&amp;E agrees with this area of concern and recently updated its welder qualification documents adding a number of improvements and updates.</p> <ul style="list-style-type: none"> <li>•</li> <li>• Welder Qualification for Under 20% SMYS test form FD-30-B is now TD-4160P-30-F01, <i>“Welder Performance Qualification Record – 60 psig and less”</i></li> </ul> <p>The procedure updates that address the areas of concern include the following:</p> <p>2a) &amp; b) PG&amp;E added language to the procedures requiring a lapse in qualification be documented in the <i>“Memo to File”</i> section of form TD-4160P-30-F01. Additionally, PG&amp;E added a Supervisor notification requirement for any disqualification to be documented on form TD-4160P-30-F01. Supervisor notifications are performed immediately following a test failure either face to face or by telephone and do not require a separate email, therefore keeping email notification would be impractical.</p> <p>2c) PG&amp;E has revised form TD-4160P-F01 to include a <i>“PASS”</i> or <i>“FAIL”</i> checkbox on the top of the form indicating an overall pass or failure for the test assembly.</p>
--

**ATTACHMENTS**

<b>Attachment #</b>	<b>Title or Subject</b>
TD-4160P-30-F01	Welder Performance Record for 60 psig and Less

**ACTION REQUIRED**

Definitions:      NOV – Notice of Violation  
                           AOC – Area of Concern  
                           AIR – Additional Information Requested



**General Order 112-E Findings  
CPUC Inspection Report, dated June 14, 2013  
General Construction, Welding, and Plastic Joining**

<b>Action To Be Taken</b>	<b>Due Date</b>	<b>Completion Date</b>	<b>Responsible Dept.</b>
NA			

Definitions:      NOV – Notice of Violation  
                          AOC – Area of Concern  
                          AIR – Additional Information Requested

**General Order 112-E Findings  
CPUC Inspection Report, dated June 14, 2013  
General Construction, Welding, and Plastic Joining**

**INSPECTION INFORMATION**

Inspection Dates	Finding	CPUC Contact	CPUC Phone #
December 4-6, 2012	AOC-3	Aimee Cauguiran	(415) 703-2055

**INSPECTION FINDING**

CPUC Finding	<p><b>A. Areas of Concern</b></p> <p><b>3. Plastic Connection Qualification Standard and Records</b></p> <p>SED evaluated Qualifications for Joining Plastic Pipe Standard, D-34, Rev. #4, 02-11-10, (Joining Plastic Pipe Standard, D-34) and Plastic Connection Qualification Test Report, FD-34-A and noted the following:</p> <p>a) General Information, Item 3.A of Joining Plastic Pipe Standard, D-34, states “The Plastic Connection Qualification Test Report shall be kept for a period of 5 years from the last date entered on the report.”</p> <p>SED reviewed plastic connection qualification test reports and did not find the deformation records for socket fusion, saddle fusion, 2”-4” Butt (mechanical), 4”-8” Butt (hydraulic), and Electrofusion coupling and saddle deformation test records of two employees. PG&amp;E’s employee records only showed their annual verifications. PG&amp;E did not keep deformation test records since some employees obtained their initial qualifications by passing deformation tests more than five years ago and did not need to repeat the deformation tests for the following years.</p> <p>According to the current record retention policy, PG&amp;E only maintains plastic fusion records documented in the last five years. As can be seen in the following Table, <span style="border: 1px solid black; padding: 0 20px;">Redacted</span> <span style="border: 1px solid black; padding: 0 20px;">Redacted</span> passed the deformation tests in 2002; however, PG&amp;E did not keep these records in the employees’ qualification folders.</p> <table border="1" style="margin-left: auto; margin-right: auto;"> <thead> <tr> <th>Employee Name</th> <th>Last Visual Test Date</th> <th>First Visual Test Date</th> <th>Deformation Test Date</th> </tr> </thead> <tbody> <tr> <td><span style="border: 1px solid black; padding: 0 20px;">Redacted</span></td> <td>6/5/12</td> <td>6/5/06</td> <td>7/23/02</td> </tr> <tr> <td><span style="border: 1px solid black; padding: 0 20px;">Redacted</span></td> <td>11/26/12</td> <td>11/16/06</td> <td>12/5/02</td> </tr> </tbody> </table>	Employee Name	Last Visual Test Date	First Visual Test Date	Deformation Test Date	<span style="border: 1px solid black; padding: 0 20px;">Redacted</span>	6/5/12	6/5/06	7/23/02	<span style="border: 1px solid black; padding: 0 20px;">Redacted</span>	11/26/12	11/16/06	12/5/02
Employee Name	Last Visual Test Date	First Visual Test Date	Deformation Test Date										
<span style="border: 1px solid black; padding: 0 20px;">Redacted</span>	6/5/12	6/5/06	7/23/02										
<span style="border: 1px solid black; padding: 0 20px;">Redacted</span>	11/26/12	11/16/06	12/5/02										

Definitions:      NOV – Notice of Violation  
                           AOC – Area of Concern  
                           AIR – Additional Information Requested

**General Order 112-E Findings  
CPUC Inspection Report, dated June 14, 2013  
General Construction, Welding, and Plastic Joining**

	<p>After our discussion with PG&amp;E representatives, PG&amp;E was able to locate the original deformation test results in its archived qualification reports. SED recommends that PG&amp;E maintain the last deformation test records in its employees' active qualification folders even if the tests were administered five years prior to the current date. PG&amp;E should also change its record keeping retention policy to add this exception to provide complete qualification history of employees.</p> <p>b) PG&amp;E's Joining Plastic Pipe Standard, D-34, General Information, Item 10 states <i>"If a connection fails any of the required tests specified in this numbered document, the individual is not qualified in that specific type of connection, but may be qualified for other type(s) of connection(s) if the person passed the required tests. However, if the failure occurred in the socket and saddle fusion assembly, the individual is not qualified for any heat fusion joining."</i></p> <p style="padding-left: 40px;">i. During the audit, PG&amp;E representatives explained that heat fusion also includes electrofusion even though the Plastic Connection Qualification Test Report, FD-34-A lists them separately. Therefore, Item 10 of Joining Plastic Pipe Standard, D-34 should be revised to include electrofusion to heat fusion joining category and the criteria should mention specifically that an individual will not be qualified for any heat fusion joining including electrofusion, if failure occurs in the socket and saddle fusion assembly.</p> <p style="padding-left: 40px;">ii. Item 4 of Joining Plastic Pipe Standard, D-34 states <i>"Company contractors and QC/Ss must meet the same qualifications as Company employees to perform connections. Under no circumstances, shall individuals perform work for which they are not qualified or have been disqualified. Company contractors and QC/Ss shall be qualified for only the specific connections for the particular job to which they are assigned. There will be no minimum socket and saddle fusion assembly test requirements unless the Company contractor or QC/S will be performing those particular fusions on the job to which they have been assigned..."</i></p>
--	--

Definitions:      NOV – Notice of Violation  
                           AOC – Area of Concern  
                           AIR – Additional Information Requested

**General Order 112-E Findings  
CPUC Inspection Report, dated June 14, 2013  
General Construction, Welding, and Plastic Joining**

	<p>SED noted that if a PG&amp;E employee fails socket or saddle fusion tests, the individual is not qualified for any heat fusion joining including electrofusion as per Item 10. However, this requirement does not apply to company contractors and subcontractors as per Item 4 because there is no minimum socket and saddle fusion assembly test requirement unless the company contractors or subcontractors perform those particular fusions on the job to which they have been assigned.</p> <p>For example, PG&amp;E's contractor [Redacted] took electrofusion, mechanical, 2"-4" butt (mechanical), socket, and saddle fusion tests on 11/13/12. [Redacted] passed all the tests but the saddle fusion test. On 11/16/12, [Redacted] took 4"-8" butt (hydraulic) fusion test and passed. According to PG&amp;E's standard D-34, if a PG&amp;E employee fails the saddle fusion test, the employee would not be qualified for any heat fusion joining. However, since [Redacted] was a contractor, he was offered to take a 4"-8" butt fusion joining test and after he passed it, he was qualified to perform 4"-8" butt fusion. SED suggests that PG&amp;E apply the same rules to its contractors and subcontractors. [Redacted] should not have been qualified for any heat fusion joining since he failed the saddle heat fusion test three days prior to 4"-8" butt fusion test. However, PG&amp;E's current Standard D-34, Item 4 allowed him to take the test again and become qualified if successful.</p> <p>SED recommends that PG&amp;E should have the same plastic joining test criteria for all employees including PG&amp;E contractors and subcontractors. PG&amp;E should revise its Joining Plastic Pipe Standard, D-34, to add the minimum heat fusion passing criteria for all employees, contractors, and subcontractors in order to be qualified for all plastic fusion methods.</p> <p>c) Joining Plastic Pipe Standard, D-34, Test Assembly for Mechanical Connection Qualification, Item 21.B states "Properly install a Met-fit or Continental stab-type fitting..."</p> <p>PG&amp;E's Utility Bulletin: TD-B-91.1B-001 (publication date: 10/04/2011, rev: 0) states "This bulletin announces that MetFit brand mechanical fittings are no longer available for purchase, and will no longer be approved for use as a connection method</p>
--	---

Definitions:      NOV – Notice of Violation  
                           AOC – Area of Concern  
                           AIR – Additional Information Requested

**General Order 112-E Findings  
CPUC Inspection Report, dated June 14, 2013  
General Construction, Welding, and Plastic Joining**

	<p>for plastic pipe effective November 1, 2011.”</p> <p>Therefore, PG&amp;E needs to exclude MetFit brand mechanical fittings from all related standards and procedures by revising Joining Plastic Pipe Standard, D-34, Utility Work Procedure WP4170-08, Polyethylene Mechanical Fitting Connections, Utility Standard S4170- Plastic Pipeline Design, Construction, Maintenance, and Operation. Other related standards may include GS&amp;S A-90- Plastic Main and Service Installation, GS&amp;S A-93- Polyethylene Pipe Specifications and Design Considerations, and GS&amp;S A-93.1 Plastic Gas Distribution System Construction and Maintenance</p> <p>d) SED noted that PG&amp;E’s Plastic Connection Qualification Test Report, FD-34-A shows that when an employee fails a test, the employee’s supervisor must be notified of the failure. However, there are no instructions in the related standard to inform an employee’s supervisor when employee fails all or any of the plastic fusion tests.</p> <p>SED suggests that PG&amp;E have its supervisors informed for any type of plastic connection test failures. Even if an employee passes the minimum required tests (i.e., heat fusion), but fails other tests, there should be a requirement to inform the employee’s supervisor of any failure. Additionally, this requirement should be included in PG&amp;E’s Joining Plastic Pipe Standard, D-34.</p> <p>Similarly, form FD-34-A also has a required “MEMO TO FILE” field for only company employees, which PG&amp;E needs to fill out when an individual has not performed deformation qualification tests or annual verification connections in the last 12 months after the last test date. However, if a PG&amp;E employee has a partial lapse, (i.e., qualified to perform at a minimum socket and saddle heat fusion, but may not be qualified to perform butt fusion, electrofusion, or mechanical connections) PG&amp;E does not need to prepare a memo to the employee’s file.</p> <p>SED recommends that if there are any lapses in an employee’s qualification records for performing any type of plastic connection, PG&amp;E should have a memo to file prepared to indicate the type of plastic fusion that the employee is not</p>
--	--

Definitions:      NOV – Notice of Violation  
                           AOC – Area of Concern  
                           AIR – Additional Information Requested

**General Order 112-E Findings  
CPUC Inspection Report, dated June 14, 2013  
General Construction, Welding, and Plastic Joining**

	<p>qualified to perform. Additionally, PG&amp;E should add this requirement to its Joining Plastic Pipe Standard, D-34.</p> <p>e) PG&amp;E's Joining Plastic Pipe Standard, D-34, General Information, Item 11 states <i>"If an individual who fails a qualification test may be retested immediately. The person must prepare two additional samples of each connection type that failed, and both of these samples must pass the required tests."</i></p> <p>SED reviewed related records and noted that if an employee fails a qualification test and is retested immediately and passes two additional tests, the records show only one pass record, not the original failed test and the second passed test result. There is no documentation showing that the employee successfully passed two tests by preparing two additional samples of each connection type that failed.</p> <p>SED recommends that PG&amp;E should keep all records showing how many times the employee attempted to pass the test including the failed test records.</p>
--	---

**PG&E RESPONSE**

	<p>3a) PG&amp;E's agrees with this recommendation. When D-34 is revised, PG&amp;E will include requirements to maintain the last deformation test records in its employees' active qualification folders even if the tests were administered five years prior to the current date.</p> <p>3b) PG&amp;E is in the process of revising D-34 and is considering removing the heat iron fusion minimum requirements, creating separate qualifications for each fusion type, and applying uniform testing requirements to PG&amp;E employees, company contractors, and applicant installed contractors.</p> <p>3c) PG&amp;E agrees with this recommendation. Some of these documents are currently being revised for fourth quarter publication and will include the SED recommendation.</p> <p>3d) PG&amp;E agrees with this recommendation. When D-34 is revised, connection qualification "MEMO TO FILE" requirements will include any lapses in an individual's connection qualifications.</p> <p>3e) PG&amp;E views the evaluations as three components (1st attempt and/if upon failure the following 2 attempts) of a single process. In order to make it more efficient to track and</p>
--	---

Definitions:      NOV – Notice of Violation  
                           AOC – Area of Concern  
                           AIR – Additional Information Requested

**General Order 112-E Findings  
 CPUC Inspection Report, dated June 14, 2013  
 General Construction, Welding, and Plastic Joining**

less confusing for PG&E's employees and frontline supervisors, PG&E only records and communicates if the employee is qualified or unqualified.

**ATTACHMENTS**

Attachment #	Title or Subject

**ACTION REQUIRED**

Action To Be Taken	Due Date	Completion Date	Responsible Dept.
Updates to Pipe Standard D-34	6/30/2014		Work Methods and Implementation

Definitions:      NOV – Notice of Violation  
                           AOC – Area of Concern  
                           AIR – Additional Information Requested

**General Order 112-E Findings  
CPUC Inspection Report, dated June 14, 2013  
General Construction, Welding, and Plastic Joining**

**INSPECTION INFORMATION**

Inspection Dates	Finding	CPUC Contact	CPUC Phone #
December 4-6, 2012	AOC-4	Aimee Cauguiran	(415) 703-2055

**INSPECTION FINDING**

CPUC Finding	<p><b><u>A. Areas of Concern</u></b></p> <p>4. Qualification Records of Contractor Employees</p> <p>SED found that PG&amp;E’s General Construction office where PG&amp;E keeps its Title 300 employees’ welder and plastic joining qualification records, does not maintain its contractors’ records of the jobs they have worked on. SED noted that these records are necessary, not only to confirm that qualified employees are performing the work, but to keep track of training and testing of personnel who regularly perform covered tasks.</p> <p>SED noted the following examples:</p> <p>a) SED reviewed Arc Welder qualification test records, and noted that form FD-30.2-A does not have the project or job number information.</p> <p>SED requested a list of projects that a PG&amp;E contractor employee, <span style="border: 1px solid black; padding: 2px;">Redacted</span> worked on in 2011. PG&amp;E was unable to provide this information. SED noted that in order to verify the qualifications of employees for specific projects, PG&amp;E needs to identify the projects an employee worked on the qualification form.</p> <p>b) SED reviewed Oxyacetylene Weld test records and noted that form FD-30-B does not show the project or job number.</p> <p>c) SED reviewed the plastic pipe joining qualification records of PG&amp;E’s contractors and noted that PG&amp;E did not fill-out the PM # information on Form FD-34-A, which identifies the projects or job numbers that employees worked on.</p> <p>SED recommends that PG&amp;E record the name or job number of the projects that PG&amp;E’s company employees and contractors are qualified to work on. Since PG&amp;E only hires and qualifies contractor employees for specific projects, it is important to document this information on the qualification record.</p> <p>SED recommends that PG&amp;E record the name or job number of the projects (PM #) that PG&amp;E’s contractors are qualified to work on.</p>
--------------	--

Definitions:      NOV – Notice of Violation  
                           AOC – Area of Concern  
                           AIR – Additional Information Requested



**General Order 112-E Findings  
CPUC Inspection Report, dated June 14, 2013  
General Construction, Welding, and Plastic Joining**

**PG&E RESPONSE**

4. PG&E Contractors provide services and labor under many different contracts. Some contracts are alliance contracts, in which work is performed on multiple jobs and/or projects requiring welding and/or plastic connections. Welding and Plastic connection qualification testing is performed prior to the first assignment. Once the contractor's employee is qualified for a particular task, that employee may move to additional projects and perform the same tasks that he/she is qualified for. The qualification is verified by local personnel (e.g. Supervisor, Project Manager, Job Inspector, etc.) before performing any tasks on the new project. Therefore documenting each project on the original qualification form that is centrally located in the Qualification Departments record file is impractical.

The reference to job number (PM#) on the plastic qualification form D-34-A is for Applicant contractors or subcontractors that perform work on a specific project. The contractor or subcontractor does not have a contract with PG&E therefore documenting the job number is important. These records are stored with the job file and not centrally located in PG&E's qualification department's record file.

**ATTACHMENTS**

Attachment #	Title or Subject

**ACTION REQUIRED**

Action To Be Taken	Due Date	Completion Date	Responsible Dept.

Definitions:      NOV – Notice of Violation  
                           AOC – Area of Concern  
                           AIR – Additional Information Requested

# Attachments



## Welder Performance Qualification - API-1104 Procedures

### Summary

This document provides Pacific Gas and Electric (Company) requirements for:

- Performance qualification for employees in accordance with API-1104, "Welding of Pipelines and Related Facilities."
- Selection, administration, and documentation of performance qualification tests.
- Maintenance of qualifications.

All welders must qualify based on the requirements of this document before starting work. Qualification is mandatory when welding on any part of Company's gas system operating above 60 pounds per square inch gauge (psig).

Company qualified welders may produce welds in all parts of Company's gas system regardless of stress level.

Level of Use: Informational Use

### Target Audience

Company welders and individuals responsible for performance qualification process.

### Safety

SERIOUS injury may occur if improperly performing a weld performance qualification:

- Eye injury may result from improper use of safety goggles or welding mask.
- Electrical shock may result from improper use of procedure examination section.
- Burns may occur from improper use of gloves and attire when handling the weld.

### Before You Start

The following personal protective equipment (PPE) inspection tools are recommended:

- Safety glasses
- Welding hood



**Welder Performance Qualification - API-1104 Procedures**

- Welding gloves
- Long sleeve attire
- Hi-lo gauge
- V-Wac gauge or undercut gauge
- Weld reinforcement gauge and fillet weld gauge
- Paint marker
- 6 inch ruler

**Table of Contents**

Subsection	Title	Page
1	Administration Requirements .....	2
2	Performance Qualification .....	3
3	Limitations.....	4
4	Essential Variables Requiring Requalification .....	4
5	Examinations .....	6
6	Qualification Renewal .....	11
7	Guidelines for Retesting .....	11
8	Revoking Qualifications.....	12
9	Welder Identification .....	12
10	Records .....	13
	Appendix 1, Tables And Figures .....	16

**Procedure Steps**

**1 Administration Requirements**

- 1.1 Company's welder performance qualification test administrator must supervise all welder performance qualification and requalification tests.
- 1.2 Test administrator must:
  1. Pass Company's Operator Qualification, Task 10-02.
  2. Have 10 or more years of experience as a journeyman pipe welder OR hold a valid American Welding Society (AWS) QC-1 Certified Welding Inspectors (CWI) Certificate.



## Welder Performance Qualification - API-1104 Procedures

3. Have thorough knowledge and complete comprehension of the following:
  - Title 49 Code of Federal Regulations (CFR) Part 192, "Transportation of Natural and Other Gas by Pipeline: Minimum Federal Safety Standards."
  - API-1104, Section 6, "Qualification of Welders" and Section 9, "Acceptance Standards for Nondestructive Testing"
  - Company's Welding Procedure Specifications (WPS)
- 1.3 Test administrator may terminate a qualification test at any point during the process if it becomes apparent that welder lacks sufficient skill to produce desired results.

### 2 Performance Qualification

#### 2.1 Qualification Tests:

1. Welder performance qualification test sheets presented in the Attachments may be used to administer a qualification test. The test sheets describe the standard test conditions under which the test is typically administered including base material type, filler metal grouping, joint design, welding process, and qualification ranges.
2. Welder performance test sheets serve as a guide for a standardized method in testing and are not considered all inclusive of the scope of tests that may be administered for welder qualification.
3. Qualification tests may be created or modified to suit the needs of a specific project. Refer to Section 4, "Essential Variables Requiring Requalification" of this document for a discussion of the essential variables for performance qualification to be considered when creating or modifying qualification tests.
4. The welder performance qualification test sheet and applicable WPS should be made available to the welder for review prior to taking the test. Performance test coupons must be welded in strict compliance with the WPS referenced in the qualification test sheet.

#### 2.2 Qualification Levels:

1. A welder must be qualified to either a multiple qualification level OR a single qualification level, see below:
  - a. Multiple qualification welders are considered qualified for this level after successfully completing both tests listed below:
    - (1) Produce a butt weld on 12-3/4 inch outside diameter (OD) by 0.375 inch wall thickness (WT) pipe in either a fixed position with pipe axis in the horizontal (5G) position or inclined position from the horizontal plane at a 45-degree (6G) position



## Welder Performance Qualification - API-1104 Procedures

- (2) Layout, cut, fit, and weld a full-sized branch-on-pipe connection on 12-3/4 inch OD by 0.375 inch nominal WT pipe. A full size hole must be cut in the run-pipe. Make weld with the run-pipe axis in the horizontal position and the branch-pipe extending vertically down.
  - (3) Welders working on multiple projects with varying scope must be qualified to the Multiple Qualification level.
2. Single qualification welder is considered qualified upon successfully completing the test listed below:
- (1) Produce a butt weld on 12 3/4 inch OD by 0.375 inch WT pipe in either a fixed position with pipe axis in the horizontal (5G) position or inclined position from the horizontal plane at a 45-degree (6G) position.
  - (2) Qualification tests performed on pipe diameters not listed in this section may be required to qualify within the essential variables required by the scope of work.
  - (3) Personnel welders whose work will be isolated to a specific project may possess single qualification.

### 3 Limitations

- 3.1 Welders whose qualification is based on nondestructive testing (NDT) may not weld on pipe or components at a compressor station.
- 3.2 Welders whose qualification is based on a single qualification test are ONLY approved to weld within the test qualification joint design and welder essential variables described in Section 4 below. However, welders are permitted to hold more than one qualification concurrently that are based on a single qualification test, if needed by their project work.
- 3.3 Welders whose qualification is based on a multiple qualification test with pipe of an OD greater than or equal to 12" nominal OD are approved to weld with multiple WPS's covering all positions, all wall thicknesses, all joint designs, and all pipe diameters. Welder's whose qualification is based on a multiple qualification test less than 12" nominal OD pipe are approved to weld with multiple WPS's grouped per the essential variables described in Section 4 below.

### 4 Essential Variables Requiring Requalification

- 4.1 A welding performance qualification test determines a welder's ability to deposit sound weld metal under a fixed set of conditions known as essential variables. The test establishes the welding limits or ranges of the essential variables in which qualified welder is permitted to perform.



## Welder Performance Qualification - API-1104 Procedures

4.2 API-1104 code prohibits a welder to weld outside of the qualification range.

1. If welding outside of the qualification range is desired or needed, then welder must requalify using a procedure that incorporates the new essential variable.
2. Descriptions of essential variable limits are as follows:
  - a. Process: A change from one welding process to another welding process, or a combination of welding processes. A welder who completes separate qualification tests using separate welding processes is qualified to use them independently or together in producing welds.
  - b. Progression: A change in the direction of welding from vertical up-hill to vertical down-hill and vice versa.
  - c. Filler metal: A change in classification from:
    - Group 1 or 2 to 3 (Cellulose to Low-Hydrogen)
    - Group 3 to 1 or 2 (Low-Hydrogen to Cellulose)
    - See Table 1 below, "Filler Metal Classification Group" for more details.

**Table 1. Filler Metal Classification Group**

Group	AWS Specification	Electrode	Electrode Type
1	A5.1	E6010, E6011	Cellulose
	A5.5	E7010, E7011	Cellulose
2	A5.5	E8010, E8011	Cellulose
3	A5.1	E7015, E7016, E7018	Low-Hydrogen
	A5.5	E8015, E8016, E8018	Low-Hydrogen

- d. Outside diameter (OD): A change between different OD ranges, such as:
  - Less than 2.375 inch OD
  - From 2.375 inch OD to 12.750 inch OD
  - Greater than 12.750 inch OD
- e. WT: A change between different nominal pipe WT ranges, such as:
  - Less than 0.188 inch
  - From 0.188 inch to 0.750 inch
  - Greater than 0.750 inch



## Welder Performance Qualification - API-1104 Procedures

- f. Position: A change in qualified position, such as:
  - From vertical to horizontal or vice versa
  - From rolled to fixed. A welder qualified in the fixed position is also qualified for the rolled position.
  - A welder who passes a butt weld qualification test with pipe axis in the 45-degree inclined (6G) position and fixed rotation is qualified to make butt welds and lap fillet welds in all positions.
- g. Joint design: A change in joint design, such as:
  - Weld joint backing configuration:
    - A welder qualified to weld on open butt WITHOUT backing is permitted to weld with backing
    - A welder originally qualified WITH backing is prohibited to weld open butt joints without backing
  - V-bevel to U-bevel

### 5 Examinations

- 5.1 All completed qualification test coupons must satisfy the visual examination criteria described in this section before submitting to destructive testing.
- 5.2 The use of NDT (such as radiography or ultrasonic testing) is prohibited in selecting weld sections for destructive examination.
- 5.3 Visual examination requirements for finished welds:
  - 1. Welds must have a smooth uniform appearance and conform to the following acceptance criteria:
    - a. Free of cracks, inclusions, arc strikes, or other surface defects.
    - b. Free of inadequate penetration (IP) or unrepaired burn through (BT) areas.
    - c. Free of arc burns outside of weld area.
  - 2. Internal and external undercut:
    - a. Test coupons less than or equal to 0.188 inch nominal thickness must not exceed 1/64 inches in depth.
    - b. Test coupons greater than 0.188 inch nominal thickness must not exceed 1/32 inches in depth.





## Welder Performance Qualification - API-1104 Procedures

- c. Total length of undercut is not to exceed 2 inches in any continuous 12 inches of weld, or 17% of the weld length, whichever is shorter.
  3. Internal root reinforcement is flushed with pipe inside diameter (ID) and does not exceed 1/8 inch.
  4. Weld face reinforcement must not exceed 1/8 inch with no local areas greater than 5/32 inch. The weld face reinforcement should transition smoothly with adjacent base metal and not fall below the surface of the parent metal.
- 5.4 Destructive examination for butt welds:
  1. Remove destructive test samples from qualification test coupon. Refer to [Appendix 1, "Tables and Figures," Table 1, "Butt Weld Test Sample Type and Removal Location"](#) for type and number of test samples to be removed. Refer to [Appendix 1, Figure 1, "Location of Butt Weld Test Sections"](#) for details about the removal location.
  2. Tensile strength test:
    - a. Preparation:
      - (1) Use a torch or a machine to cut tensile strength test specimens from test coupon. Test specimens must be 9 inches long by approximately 1 inch wide (see [Appendix 1, Figure 2, "Tensile Test Specimen"](#)). Specimen sides should be smooth and parallel – grind the sides to achieve desired result. Allow specimens to cool to ambient temperature before testing.
    - b. Method:
      - (1) Apply a tensile load to break test specimens. It is not necessary to calculate tensile strength of test specimens.
    - c. Acceptable test results:
      - (1) Specimen breaks outside the weld and fusion zone (i.e., in parent pipe material).
      - (2) Specimen breaks in the weld or fusion zone but meets the nick break test requirements stated in Section 5.4.4.c.



## Welder Performance Qualification - API-1104 Procedures

3. Guided bend test (root, face, OR side):
  - a. Preparation:
    - (1) Root and Face:
      - Use a torch or machine to cut root and face guided bend test specimens from test coupon. Test specimens must be 9 inches long by 1 inch wide.
      - Round long edges of specimen (as illustrated in [Appendix 1, Figure 4](#), "Root Bend and Face Bend Test Section").
      - Grind cover pass and root bead reinforcement flush with specimen's surface. Surface must be smooth and any existing surface scratches should be light and transverse to weld.
      - Allow specimens to cool to ambient temperature before testing.
    - (2) Side:
      - Use a machine or torch cut to approximately a 9 inches long by 3/4 inch wide specimen. Specimen must be final machined or ground to a 1/2 inch width.
      - Specimens must have a smooth surface with parallel sides.
      - Grind cover pass and root bead reinforcement flush with specimen's surface.
      - Round long edges of specimen as illustrated in [Appendix 1, Figure 5](#) "Side Bend Test Specimen."
      - Allow specimens to cool to ambient temperature before testing.
  - b. Method:
    - (1) Bend specimens in a guided bend test jig (see [Appendix 1, Figure 3](#) "Guided Bend Test Jig"). Place each specimen on the die with the weld at mid-span. Place face-bend specimen so that weld face points toward the die gap. Place the root-bend specimen so that root of weld points toward die gap. Force the plunger into the die gap until the specimen curvature forms a U shape.
  - c. Acceptable test results:
    - (1) Cracks or other defects in the weld or between weld and fusion zone are less than or equal to 1/8 inch or one-half of the nominal wall thickness, whichever is smaller.



## Welder Performance Qualification - API-1104 Procedures

- (2) Cracks which originate along edges of specimen are less than  $\frac{1}{4}$  inch when measured in any direction and no evidence indicates they originate from an obvious defect such as slag, lack of fusion, or porosity.

4. Nick break test:

a. Preparation:

- (1) Use a torch or machine to cut nick break test specimens from test coupon. Test specimens should be 9 inches long by 1 inch wide (see [Appendix 1, Figure 6](#), "Nick Break Test Specimen").
- (2) Create a  $\frac{1}{8}$  inch notch at the center of the weld on each side of the specimens.
- (3) Create external reinforcement notch of less than  $\frac{1}{16}$  inch depth measured from the original weld surface.
- (4) Allow specimens to cool to ambient temperature before testing.

b. Method:

- (1) Break specimens by either pulling them in a tensile machine or by supporting the ends while striking the center. Ensure that exposed area of the fracture is a minimum of  $\frac{3}{4}$  inch wide.

c. Acceptable test results:

- (1) Exposed surface of each specimen must show complete penetration and fusion. Any flaws must meet the following criteria:
  - Greatest dimension of gas pocket must not exceed  $\frac{1}{16}$  inch and the combined area of gas pockets must not exceed 2% of exposed area.
- (2) Slag inclusions must not be more than  $\frac{1}{32}$  inch in depth,  $\frac{1}{8}$  of an inch or  $\frac{1}{2}$  the nominal WT in length, whichever is shorter. There must be at least  $\frac{1}{2}$  inch between adjacent inclusions. Measure dimensions as shown in [Appendix 1, Figure 7](#), "Evaluation of Slag Inclusions in Nick Break Test Sample."



## Welder Performance Qualification - API-1104 Procedures

### 5.5 Destructive examinations for branch welds:

1. Remove destructive test samples from qualification test coupon. See [Appendix 1, Table 2](#), "Branch Weld Destructive Test Sample Type and Number" for type and number of test samples to be removed. See Figure 8, "Branch Weld Location of Test Specimens" for details about the removal location.
2. Nick Break Test
  - a. Preparation
    - (1) Use a machine or torch to cut nick break specimens approximately 2 inches wide and long enough to be gripped for breaking (see [Appendix 1, Figure 8](#)).
    - (2) Torch cut both sides of test specimens approximately 3/8 of an inch (see [Appendix 1, Figure 8](#)).
    - (3) Notch both sides of test specimens with hack-saw or grinding disk approximately 1/8 of an inch, leaving test surface at least 1 inch wide.
    - (4) Notch the centerline of the weld reinforcement for a depth of 1/16 of an inch (see [Appendix 1, Figure 8](#)).
    - (5) Allow specimens to cool to ambient temperature before testing.
  - b. Method
    - (1) Break specimens by pressing with a vice OR pulling with a tensile machine and ensure that exposed area of fracture is at least 1 inch wide.
  - c. Acceptable Test Results
    - (1) Exposed surface of each specimen must show complete penetration and fusion. Any flaws must meet the following criteria:
      - Greatest dimension of gas pocket must not exceed 1/16 of an inch and combined area of gas pockets must not exceed 2% of exposed area.
    - (2) Slag inclusions must not be more than 1/32 inch in depth, 1/8 of an inch or 1/2 the nominal WT in length, whichever is shortest. There must be at least 1/2 inch between adjacent inclusions. Measure dimensions as shown in [Appendix 1, Figure 7](#) "Evaluation of Slag Inclusions in Nick Break Test Sample."



## Welder Performance Qualification - API-1104 Procedures

### 5.6 Radiographic examination for butt welds ONLY:

1. Radiographic examination of welder qualification must be performed and inspected in accordance with Company standards.
2. If a welder qualification or qualification renewal weld coupon fails to meet acceptance criteria, any additional retests administered must be evaluated by destructive means. If a welder qualification renewal by radiography is reinterpreted following the original interpretation, then disposition of the qualification will be determined by most recent film interpretation of the same weld. Should a qualification decision change, consult with the qualification group and the document owner for next steps.

## 6 Qualification Renewal

6.1 Welder's qualification must be renewed no later than the last day of the sixth calendar month following the month in which last previous test was passed.

6.2 If the sixth month expires before renewal, then all qualifications for that welding process will lapse AND individual's supervisor is notified of disqualification. Welder must retake all qualification tests for that welding process in order to restore prior qualifications.

### 6.3 Renewal:

1. For renewal, welder must pass a radiographic examination of a production butt weld OR successfully repeat qualification test as described in Section 5, "Examinations."
2. If results of the first renewal are unacceptable, test administrator may give welder a second opportunity (see Table 2, "Optional Retest Guidelines").
3. For renewal, a welder must pass a destructive butt weld qualification test once every two years. Renewal by radiographic examination of a production butt weld may be performed consecutively between destructive intervals. If there is reason to question the welder's ability, destructive qualification test must be administered at the next renewal.

## 7 Guidelines for Retesting

7.1 If a welder qualification or qualification renewal test weld fails to meet acceptance criteria, then test administrator may give a retake at his discretion.

7.2 Test administrator may use Table 2 to see suggested courses of action for retesting.



## Welder Performance Qualification - API-1104 Procedures

**Table 2. Optional Retest Guidelines**

Cause of Failure	Course of Action
Minor visual defect isolated to 1 location OR 1 destructive test coupon fails testing	Administer an immediate retest of failed test weld.
Visual defects in 2 or more areas OR 2 or more destructive test coupons fail testing OR Failure to comply with safety or procedural issue as covered in pre-job tailboard.	Administer an immediate retest consisting of 2 weld tests for each failed test. <sup>1</sup> OR Impose a 30 day waiting period before administering the original qualification test. <sup>2</sup>
3 failed attempts to qualify in a 12 month period.	Impose a 12 month wait period starting on date of first failed test before administering the original qualification test again. <sup>2</sup>

Note<sup>1</sup>- If the 2 for 1 test option is taken, then both test assemblies must pass to satisfy qualification test.

Note<sup>2</sup> - Company advises that welder performs additional training and practice during wait period as prescribed by test administrator.

### 8 Revoking Qualifications

- 8.1 Company may revoke qualification if there is specific reason to question welder's ability to produce sound welds. The qualification department must be notified of disqualification in writing.
- 8.2 Welder may reinstate qualifications after successful completion of training and testing program given by qualification department. Requalification tests must be evaluated by destructive means only.

### 9 Welder Identification

- 9.1 Company's work methods and implementation (WM&I) qualifications group assigns a unique identification number to each welder who successfully completes a performance qualification test. This number or symbol is used to identify each welder's production work.



## Welder Performance Qualification - API-1104 Procedures

### 10 Records

- 10.1 Performance qualification records for all welders qualified within this procedure must be documented as follows:
  1. Record qualification by destructive testing on Form TD-4160P-31-F01, "Welder Performance Qualification Record."
  2. Record qualification by radiographic testing on Form TD-4160P-31-F02, "Welder Performance Record Radiography."
- 10.2 All qualification and requalification test records must be maintained for a minimum of 5 years.
- 10.3 Supervisor must be notified for any failure, disqualification, or lapse in qualification. This is documented on the respective qualification form for qualification by destructive testing or radiographic testing; TD-4160P-31-F01 OR TD-4160P-31-F02.
- 10.4 A separate test record must be completed for each qualification or renewal test performed.

**END of Instructions**



## Welder Performance Qualification - API-1104 Procedures

### Definitions

NA

### Implementation Responsibilities

NA

### Governing Document

Utility Standard TD-4160S, "Welding Control Standard"

---

### Compliance Requirement/ Regulatory Commitment

49 CFR, Part 192, Subpart E, "Welding of Steel in Pipelines"

---

### Reference Documents

#### Developmental References:

49 CFR, Part 192, Subpart E, "Welding of Steel in Pipelines"

API-1104, "Welding of Pipelines and Related Facilities"

#### Supplemental References:

49 CFR, Part 192, Subpart E, "Welding of Steel in Pipelines"

API-1104, "Welding of Pipelines and Related Facilities"

Company Welding Procedure Specifications

---

### Appendices

Appendix 1, Tables and Figures

---

### Attachments

Welder Performance Qualification Test Sheets:

MQ-Blank

MQ-1-4-4-5-G

MQ-1/2-4-4-5G

---





## Welder Performance Qualification - API-1104 Procedures

MQ-3-4-4-5G

SG-Blank

SG-1-2-2-5G

SG-1/2-2-2-5G

SG-3-2-2-5G

SBr-Blank

SBr-1-2-2-5G

SBr-1/2-2-2-5G

SBr-3-2-2-5G

Qualification Test Sheet Labeling System

**Document Recision**

This document supersedes Gas Numbered Document D-30.2, "Arc Welder Qualification for Working on Pipelines that operate at over 20% of SMYS."

**Approved By**

Redacted

Manager, Design & Construction Codes & Standards

**Document Owner**

Redacted

Principal Gas Engineer, Design & Construction Codes & Standards

**Document Contact**

Redacted

Supervisor, Welding Qualifications

**Revision Notes**

Where?	What Changed?
NA	This is a new procedure.



**Welder Performance Qualification - API-1104 Procedures**

**APPENDIX 1, TABLES AND FIGURES**  
Page 1 of 5

**Table 1. Butt Weld Test Sample Type and Removal Location**

Pipe size in inches	Tensile	Nick break	Root bend	Face bend	Side bend	Total
<b>Wall thickness - 1/2" and under</b>						
2-3/8" OD thru 4-1/2" OD	0	2	2	0	0	4
Over 4-1/2" OD thru 12-3/4" OD	2	2	2	0	0	6
Over 12-3/4" OD	4	4	2	2	0	12
<b>Wall thickness - over 1/2"</b>						
Over 4-1/2" OD thru 12-3/4" OD	2	2	0	0	2	6
Over 12 3/4" OD	4	4	0	0	4	12

Note 1: Tensile test may be omitted if specimens designated for tensile test are subjected to nick break test instead.

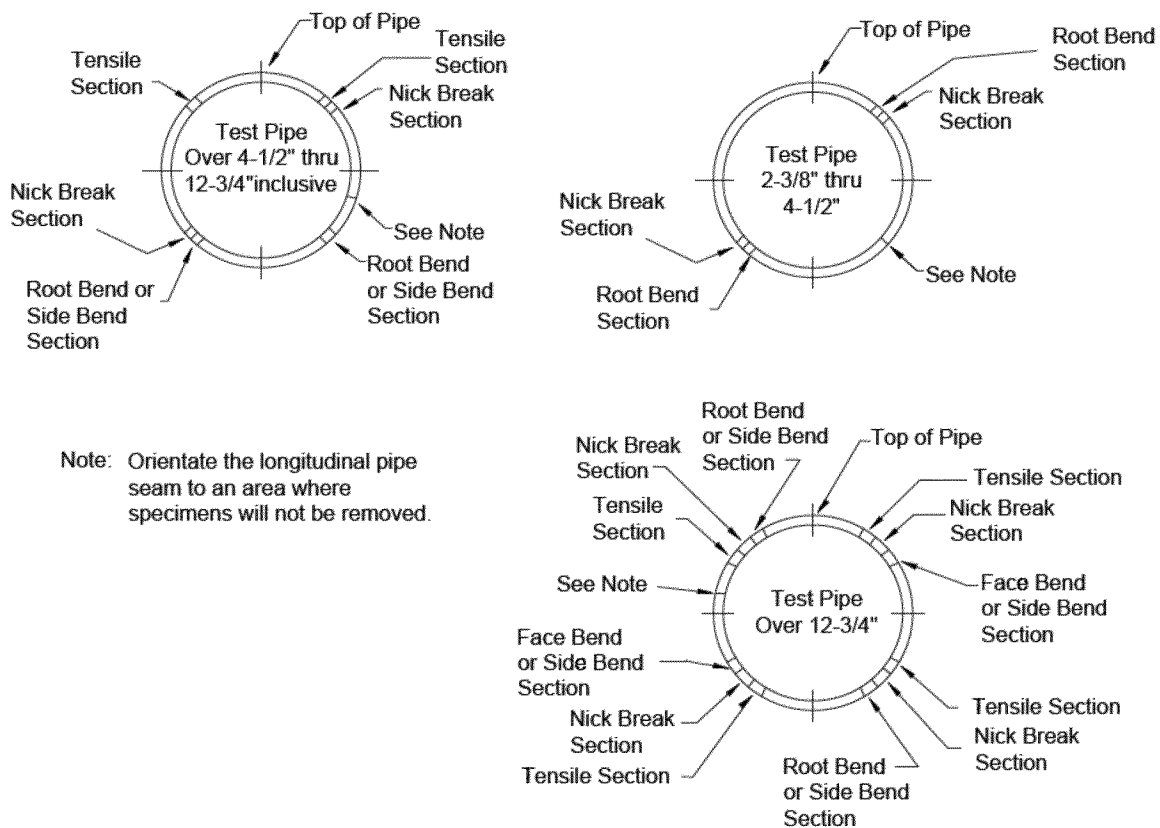
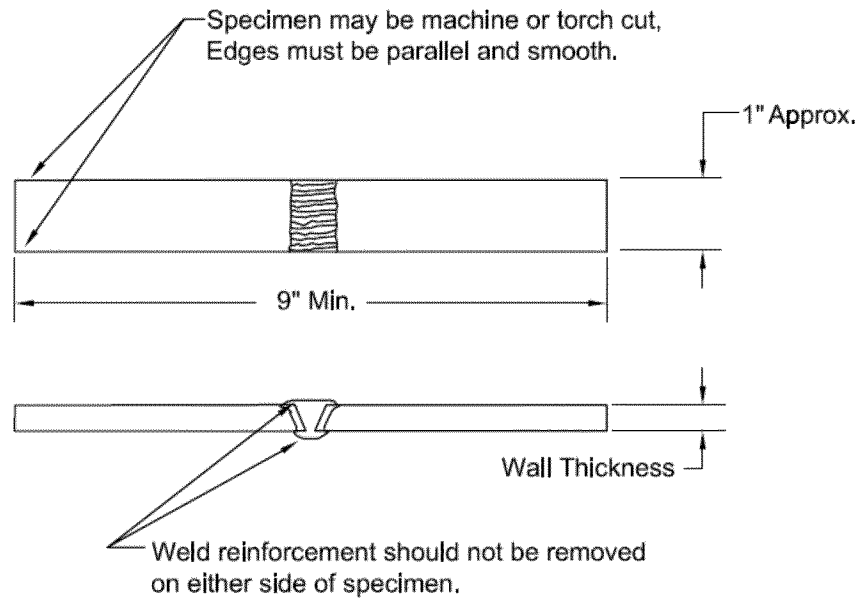

**Figure 1. Location of Butt Weld Test Sections**



## Welder Performance Qualification - API-1104 Procedures

### APPENDIX 1, TABLES AND FIGURES Page 2 of 5



**Figure 2. Tensile Test Specimen**

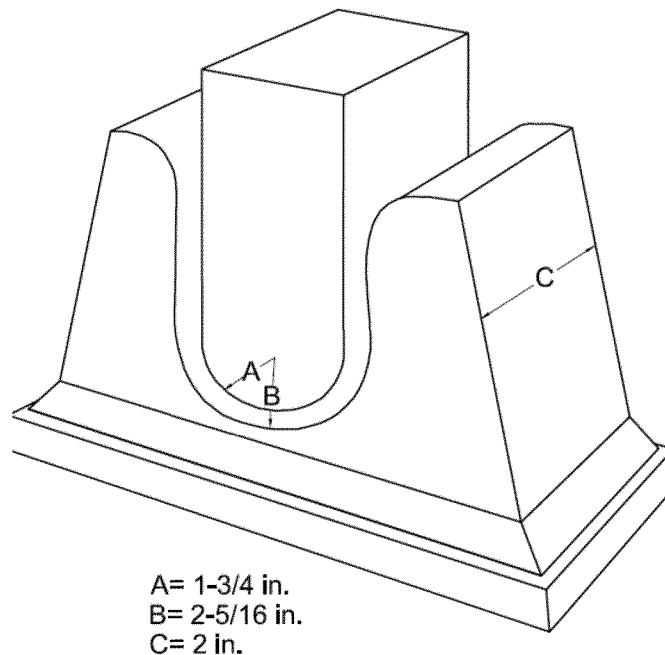
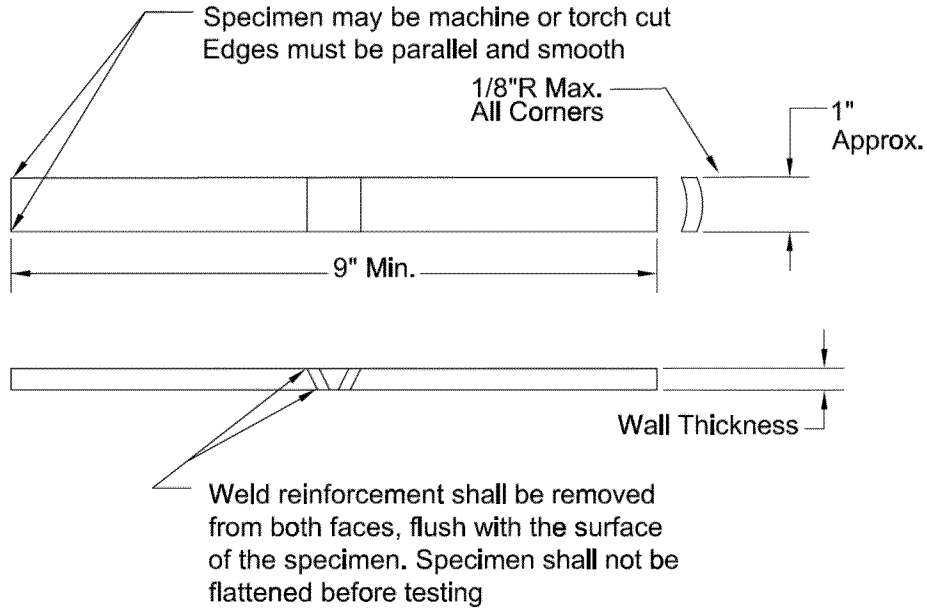

**Figure 3. Guided Bend Test Jig**



**Welder Performance Qualification - API-1104 Procedures**

**APPENDIX 1, TABLES AND FIGURES**  
Page 3 of 5



**Figure 4. Root Bend and Face Bend Test Section**

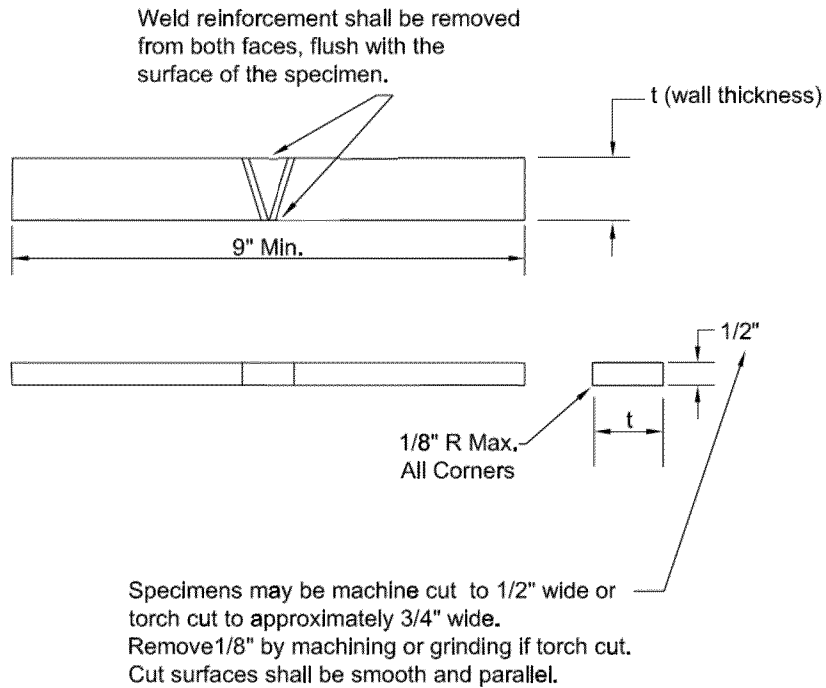

**Figure 5. Side Bend Test Specimen**



Welder Performance Qualification - API-1104 Procedures

APPENDIX 1, TABLES AND FIGURES  
Page 4 of 5

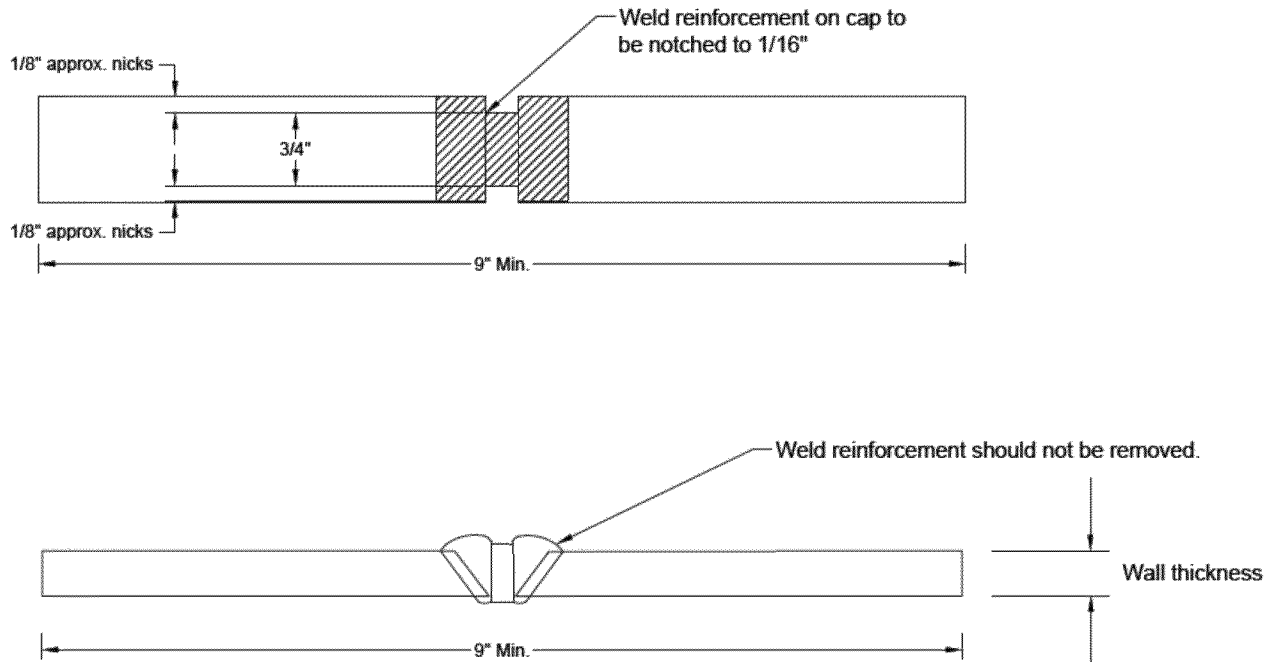

Figure 6. Nick Break Test Specimen

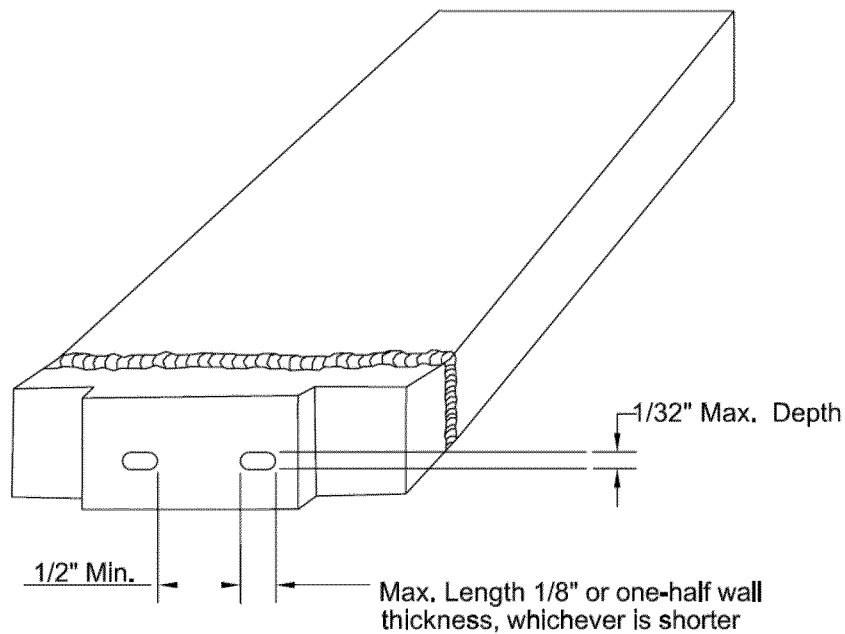

Figure 7. Evaluation of Slag Inclusions in Nick Break Test Sample



**Welder Performance Qualification - API-1104 Procedures**

**APPENDIX 1, TABLES AND FIGURES**  
Page 5 of 5

**Table 2. Branch Weld Destructive Test Sample Type and Number**

Pipe size in inches	Tensile	Nick break	Root bend	Face bend	Side bend	Total
2-3/8 and above	0	4	0	0	0	4

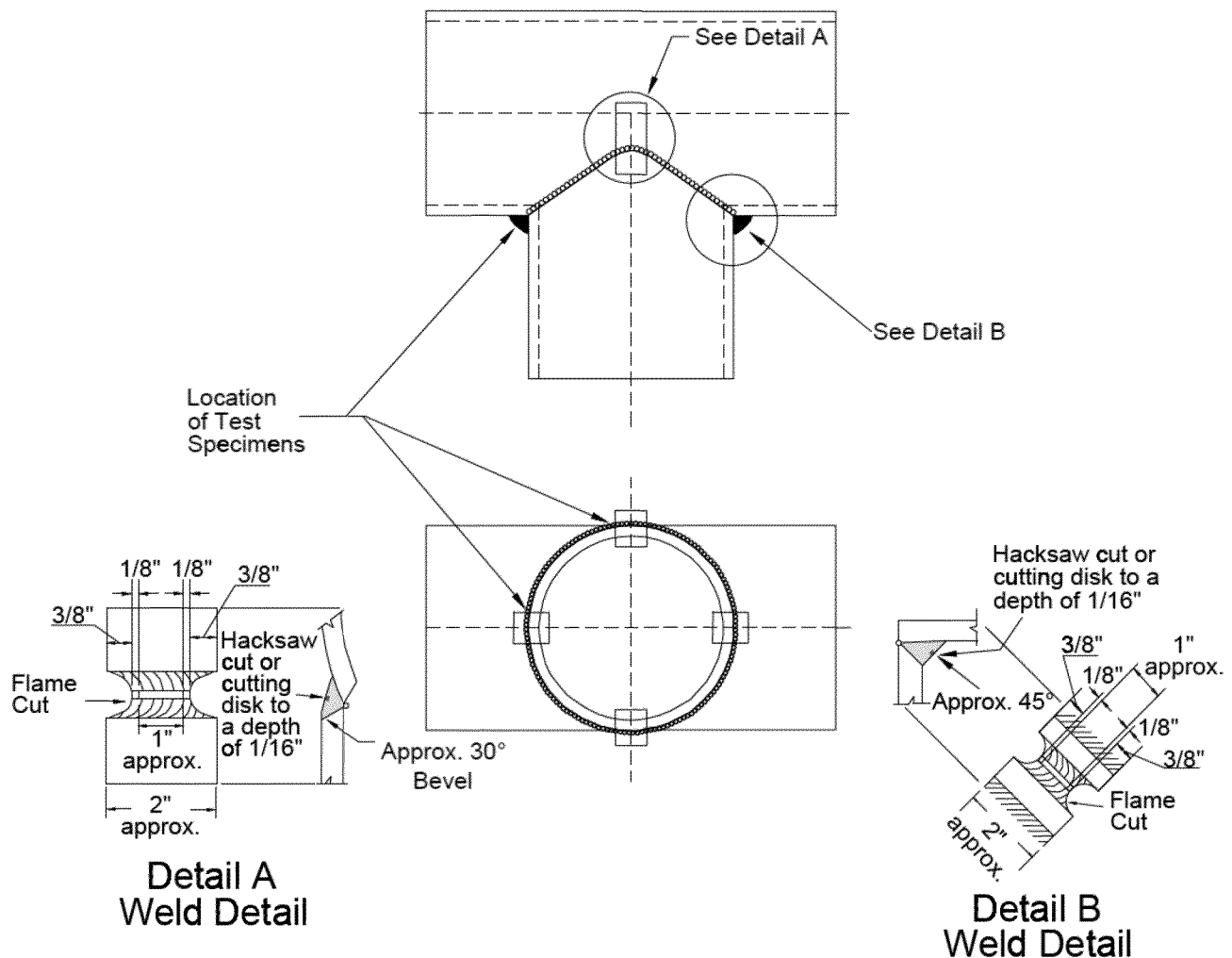

**Figure 8. Branch Weld Location of Test Specimens**



Welder Performance Record
For 60 psig and Less

Codes & Standard
06/2013
TD-4160P-30-F01

Name: [Last Name] / [First Name] Date: [ ] PASS [ ] FAILED
Expiration - last day of sixth month from date.

[ ] Per. ID or [ ] Last 4 S.S. : [ ] LanID or [ ] Stencil No :

Qualification test number: [ ] Destructive test OR [ ] Visual verification test

Weld Process: [ ] OAW / [ ] SMAW / [ ] GMAW

Pipe Diameter: [ ] Pipe Spec: [ ] Grade: [ ] Wall Thickness: [ ]

Visual Verification Test ONLY (Do not use same form for destructive testing)

Table with 3 columns: Butt Weld, Appearance (Satisfactory/Unsatisfactory), Remarks

Destructive Test ONLY (Do not use same form for visual verification testing)

Butt Weld:

Visual inspection before destructing: [ ] Satisfactory [ ] Unsatisfactory Remarks:

Table with 7 columns: Location, Penetration, Fusion, Burn through, Undercutting, Cracks, Results

Branch Weld:

Visual inspection before destructing: [ ] Satisfactory [ ] Unsatisfactory Remarks:

Table with 7 columns: Penetration, Fusion, Burn through, Undercutting, Cracks, Results

Sleeve Weld:

Visual inspection Only: [ ] Satisfactory [ ] Unsatisfactory Remarks:

Key: S = Satisfactory U = Unsatisfactory P = Pass F = Fail

Test Administrator: [ ] / [ ] Signature: [ ]

Employee's supervisor must be notified of disqualification of welder

Supervisor name: [ ] Date notified: [ ]

Company Personnel Only

Memo To File Complete the memo if the individual has not performed any qualification tests or verification welding test in the past 6 months

This memo verifies that the above individual and their supervisor were notified that the individual is no longer qualified to perform any type of welding from start date listed below until a destructive test is successfully passed. Therefore, no test records are required for this period.

Please provide a brief explanation or reason for expired qualification.

Start date: [ ] Explanation: [ ]

Signed by: [ ] Signature: [ ]



Pacific Gas and Electric Company

Welder Performance Record
API Destructive Test
All Pressure Ratings

Codes & Standards
06/2013
TD-4160P-31-F01

Name: \_\_\_\_\_ Date: \_\_\_\_\_ [ ] PASSED [ ] FAILED
Last, First

Welder's qualification must be renewed no later than the last day of the sixth calendar month following the month in which last previous test was passed.

[ ] Per No.: \_\_\_\_\_ [ ] Lan ID.: \_\_\_\_\_ Qualification
[ ] S.S. No.: XXX-XX-\_\_\_\_\_ [ ] Stencil No.: \_\_\_\_\_ Test No.: \_\_\_\_\_

[ ] EXX10 [ ] EXX18 [ ] Micro Wire [ ] Other: \_\_\_\_\_ [ ] Butt [ ] Branch

Pipe dia.: \_\_\_\_\_ Pipe spec.: \_\_\_\_\_ Grade: \_\_\_\_\_ Wall thickness: \_\_\_\_\_ Weld pos.: \_\_\_\_\_

Electrode Material

Electrical

Table with 7 columns: Pass No., Manufacturing & AWS Class, Diameter, Polarity, Amps, Volts, Direction. Rows for 1st, 2nd, and 3-Rem.

Face Bend or Side Bend (Circle one)

Table with 6 columns: Specimen, Location, No. cracks, Max. dimension, Location of defect, Remarks. Rows for specimens 1 and 2.

Root Bend or Side Bend (Circle one)

Table with 6 columns: Specimen, Location, No. cracks, Max. dimension, Location of defect, Remarks. Rows for specimens 1 and 2.

Nick Break

Table with 9 columns: Specimen No., Location, Gas pocket No., Max. dimension, Slag inclusion No., Depth, Length, Between, Fusion, Remarks. Rows for specimens 1-4.

[ ] Qualification Lapsed

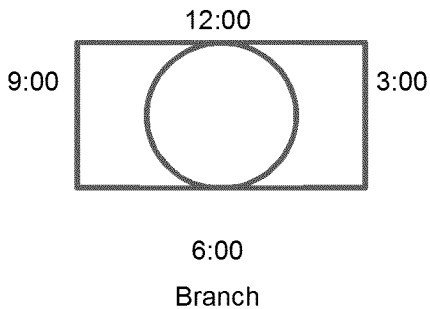

Test Administrator: \_\_\_\_\_
Test Admin. Signature: \_\_\_\_\_
Date: \_\_\_\_\_

Employee's supervisor must be notified of disqualification or lapse in qualification of welder.
Supervisor Name: \_\_\_\_\_
Date Notified: \_\_\_\_\_





# Welder Performance Record

## Radiography

API Pressure Ratings

Codes & Standards  
06/2013  
TD-4160P-31-F02

Name: \_\_\_\_\_ Date: \_\_\_\_\_  PASSED  FAILED  
Last, First

Welder's qualification must be renewed no later than the last day of the sixth calendar month following the month in which last previous test was passed.

Perf. No.: \_\_\_\_\_  Lan ID.: \_\_\_\_\_ Qualification \_\_\_\_\_  
 S.S. No.: XXX-XX-\_\_\_\_\_  Stencil No.: \_\_\_\_\_ Test No.: \_\_\_\_\_  
 EXXX10  EXXX18  Micro Wire  Other: \_\_\_\_\_

Pipe dia.: \_\_\_\_\_ Pipe spec \_\_\_\_\_ Pipe grade: \_\_\_\_\_ Wall thickness: \_\_\_\_\_

Inspection company name: \_\_\_\_\_ Job Number: \_\_\_\_\_

Inspection specification: \_\_\_\_\_ Acceptance standard: \_\_\_\_\_

RT procedure No.: \_\_\_\_\_ View  SWV  DWV Source: \_\_\_\_\_ Curies: \_\_\_\_\_

Physical source size: \_\_\_\_\_ Effective source spot: \_\_\_\_\_ Pb screen  Front  Center  Back

Source to object: \_\_\_\_\_ IQI type: \_\_\_\_\_ Wire size: \_\_\_\_\_ Source side  Film side

SFD: \_\_\_\_\_ Geometric unsharpness (UG): \_\_\_\_\_ Density: \_\_\_\_\_

Film manufacture: \_\_\_\_\_ Speed: \_\_\_\_\_ Exposure time: \_\_\_\_\_ Min.: \_\_\_\_\_ Sec.

No. film exposed: \_\_\_\_\_ Development time: \_\_\_\_\_ @ Temp: \_\_\_\_\_

Weld No.	IP	IPD	IF	CRK	EU	IU	BT	IC	ISI	ESI	HB	P	CP	ACCEPTED	REJECTED	Defect location and remarks

IP Inadequate penetration	IPD Inadequate penetration due to Hi-Lo	IF Incomplete fusion
CRK Crack	EU External undercut	IU Internal undercut
BT Burn through	IC Internal concavity	ISI Isolated slag inclusion
ESI Elongated slag inclusion	HB Hollow bead	P Porosity
CP Cluster porosity	Defect legend	
	1 - Small	2 - Moderate
		3 - Excessive

Qualification Lapsed

Employee's supervisor must be notified of disqualification or lapse in qualification of welder.  
 Supervisor Name: \_\_\_\_\_  
 Date Notified: \_\_\_\_\_

Radiographer name: _____	Level: _____
Radiographer signature: _____	
Test administrator/LanID: _____	
Test administrator signature: _____	



Welder Performance Record
For 60 psig and Less

Codes & Standard
06/2013
TD-4160P-30-F01

Name: Last Name / First Name

Date: PASS FAILED
Expiration - last day of sixth month from date.

Per. ID or Last 4 S.S. : LanID or Stencil No :

Qualification test number: Destructive test OR Visual verification test

Weld Process: OAW / SMAW / GMAW

Pipe Diameter: Pipe Spec: Grade: Wall Thickness:

Visual Verification Test ONLY (Do not use same form for destructive testing)

Table with 3 columns: Appearance (Satisfactory/Unsatisfactory) and Remarks

Destructive Test ONLY (Do not use same form for visual verification testing)

Butt Weld:

Visual inspection before destructing: Satisfactory Unsatisfactory Remarks:

Table with 7 columns: Location, Penetration, Fusion, Burn through, Undercutting, Cracks, Results

Branch Weld:

Visual inspection before destructing: Satisfactory Unsatisfactory Remarks:

Table with 7 columns: Penetration, Fusion, Burn through, Undercutting, Cracks, Results

Sleeve Weld:

Visual inspection Only: Satisfactory Unsatisfactory Remarks:

Key: S = Satisfactory U = Unsatisfactory P = Pass F = Fail

Test Administrator: Name / LANID Signature:

Employee's supervisor must be notified of disqualification of welder

Supervisor name: Date notified:

Company Personnel Only

Memo To File Complete the memo if the individual has not performed any qualification tests or verification welding test in the past 6 months

This memo verifies that the above individual and their supervisor were notified that the individual is no longer qualified to perform any type of welding from start date listed below until a destructive test is successfully passed. Therefore, no test records are required for this period.

Please provide a brief explanation or reason for expired qualification.

Start date: Explanation:

Signed by: Signature: