



A  Sempra Energysm company

<p>December 19, 2007</p>	<p>Performance Category Upgrade Request for Imperial Valley - Miguel 500 kV and Imperial Valley - Central 500 kV</p> <p>Double Line Outage Probability Analysis Seven Step Process Document</p> <p>Final Report</p> <p>Prepared By</p> <p>San Diego Gas & Electric Transmission Planning</p>
--------------------------	--

**Imperial Valley - Miguel and Imperial Valley - Central
Double Line Outage Probability Analysis
SDG&E**

Executive Summary

This report presents the seven step process for petitioning for a performance category upgrade request for the double-line outage of the existing, Imperial Valley - Miguel 500 kV line, and the proposed Imperial Valley - Central 500 kV line. The Imperial Valley - Miguel 500 kV line segment is part of the existing “Southwest Powerlink” (SWPL) which runs from the Palo Verde to Hassayampa to North Gila to Imperial Valley - Miguel substation. The Imperial Valley - Central 500 kV line is part of the proposed “Sunrise Powerlink” (SRPL) which will connect Imperial Valley substation to SDG&E’s Sycamore Canyon substation via the proposed 500/230 kV Central substation.

The proposed path for the Imperial Valley - Central 500 kV line (See Figure 1) is proposed to share a common right of way with the existing Imperial Valley - Miguel 500 kV line from the Imperial Valley substation and heading west for 4 miles (12 towers). SDG&E requests that the RPEWG approve the proposed route for the performance category upgrade to Category D with cascading allowed.

An alternative path (See Figure 1) is presented in Appendix F that is proposed to share a common right of way for 36 miles. SDG&E requests the RPEWG evaluate and decide if this alternative path is eligible for the performance category upgrade to Category D, as there are differences between the proposed and alternative paths for the Robust Line Design analysis. The Robust Line Design analysis performs an evaluation of the line’s robustness through discussion of risk factors. These factors will be discussed further in Step 4. Appendix C contains a summary of the seven step process, as well as a description of the risk factors.

This performance category upgrade request for the proposed route can be justified based on the robustness of the facilities. Under the WECC upgrade request process, a project with a mean time between failures (MTBF) greater than 30 years will qualify for Category D or if the statistics are not conclusive enough to demonstrate this, the upgrade can be justified based on the robustness of the facilities in question. For the double line outage of the Imperial Valley - Central and Imperial Valley – Miguel 500 kV lines, the statistically based MTBF cannot be conclusively set at greater than the required 30 years due to the limited amount of statistical data available. Additionally, SDG&E considers the probability of a double line outage occurring on the line segments that share a common right of way to be of such low probability of occurrence that it merits the submittal to the WECC Phase I Probabilistic Based Reliability Criteria (PBRC) Performance Category Evaluation (PCE) Process. The PCE process allows a project with an accepted MTBF in the range of 30 to 300 years as well as a thorough investigation of Robust Line Designs to be categorized as a Category D outage, with the added condition of “no cascading” allowed. A project with a MTBF in excess of 300 years is considered an “Extreme Event” similar to all other events in the NERC Category D.

This report has been prepared in accordance with the steps given by the Reliability Performance Evaluation Work Group (RPEWG), and these steps are detailed in Appendix C.

The results of the analysis of the Imperial Valley - Miguel and Imperial Valley - Central double line outage (N-2) qualify this contingency to be moved to Category D from Category C. After addressing each of the seven steps, the MTBF was calculated to be between 21 and 928 years and is based on the following probabilistic data and mitigating factors:

- The estimated MTBF for the lines is in the range of 21 to 928 years. The reason the data was presented in a range of values is due to the shortage of significant data, which is needed to determine a set MTBF. The lower end of the range, 21 years, would not qualify for Category D status, but SDG&E feels that after review of the Robust Line Design criteria for SWPL, the MTBF would tend towards the higher end of the range. This estimate was based on historical outage statistics for other parallel 500 kV lines with the statistics modified to consider mitigating factors that do not apply to the lines in this report.
- SWPL was put into service in June of 1984. SDG&E has thirteen years (1995-2007) of accurately collected data on the outages for the Imperial Valley - Miguel 500 kV line. Based on this data, there have been 44 forced outages of the Imperial Valley - Miguel 500 kV line. However, of these 44 outages, only one incident occurred on the Imperial Valley - Miguel 500 kV line segment which is proposed to share the common right of way with the Imperial Valley - Central 500 kV line. This outage occurred when an insulator flashed over during an insulator wash. For purposes of the double line outage analysis, this event would not be considered a factor because SDG&E would not perform insulator washing on both lines simultaneously. Therefore SDG&E's historical outage information shows that there are no forced outages that occurred on the shared right of way that would cause a double line outage.
- Robust line designs were taken into account including overhead ground wire protection from lightning, line separation of 400 feet in the common right-of-way and adequate separation in the Imperial Valley switchyard, which currently is configured as a ring bus arrangement. After the addition of the Sunrise Powerlink, this substation will be reconfigured to use a combination double breaker-double bus and a breaker-and-a-half arrangement with an ultimate design for a breaker-and-a-half configuration.
- Robust design factors not associated with the lines include: characteristics of the desert terrain, minimal chance of fires due to a lack of vegetation, low risk of vandalism, and low risk of flight incidents that have occurred in the corridor, thus making it an unlikely probability that there will be an incident in the future.

- The isokeraunic level or flash density is 0 - 0.25 flashes /square km/year, which is the lowest in the U.S.
- The exposure to the system is estimated to be, at worst case, 675 hours per year or 7.71% per year. However, the likelihood of this exposure in real time operations will be significantly reduced. This worst case exposure is based on planning scenarios which assume imports into the San Diego area are maximized while internal generation in the San Diego area is minimized. It is important to note, that these planning scenarios are extremely unlikely to be seen in real time operations as the San Diego Area has approximately 3000 MW of internal generation available and a projected summer peak load for 2010 of 5000 MW. It is reasonable to assume that SDG&E will have a significant amount of internal generation on-line when SDG&E's load is above 3600 MW. At 3600 MW of load and above, it is possible that imports into the San Diego area could be 3100 MW. With imports above 3100 MW, SDG&E may need to drop load for the double line outage (see discussion below). Though these planning scenarios are unlikely in normal real time operations, these conditions could be approached during extreme emergency conditions, but for the purposes of this report the expected exposure will be significantly less than the worst case estimate of 7.71%.
- Under the planning scenarios described above, the consequences to the grid of a double contingency of the Imperial Valley - Miguel and Imperial Valley - Central lines would be the need to shed enough SDG&E load to reach approximately 3100 MW of import into San Diego, assuming imports prior to the double line outage are above 3100 MW. Additional load drop may be necessary to prepare for the next contingency. For 2010, the amount of load shed would be at worst case, approximately 1000 MW given the planning scenario described to evaluate the exposure analysis. Given different scenarios which equate to more realistic operating conditions the amount of load drop necessary to meet NERC/WECC criteria would likely be reduced. The amount of load drop necessary will vary depending on system conditions in not only the San Diego area, but also in the Los Angeles and northern Baja, Mexico areas.

Based on these findings, it is recommended that the N-2 outage of the Imperial Valley - Miguel and Imperial Valley - Central 500 kV lines for the proposed path be upgraded to a Category D classification with cascading allowed¹.

Also, after reviewing the robust line design for the alternative path, SDG&E requests that the RPEWG determine if the alternative path would also qualify for the performance category exemption.

¹ Cascading would be possible only under extremely high imports into the San Diego region. With the addition of approximately 1300 MVAR of reactive support in the Southern California area cascading was not seen.

Seven Step Documentation for PBRC Adjustment for Imperial Valley - Miguel 500 kV and Imperial Valley - Central 500 kV

Step 1: Project Facility Description

The Imperial Valley - Miguel 500 kV is part of the SWPL and was built to meet the increasing need for power in San Diego. The SWPL, which lies between Arizona and California went into service in 1984 and terminates at the Miguel substation. This key east-west transmission line is routinely loaded to more than 1,000 MW during the summer and fall months. SDG&E projects that by 2010 there will be a grid reliability shortfall if additional infrastructure is not built to meet SDG&E 90/10 load forecast. SDG&E has proposed a new 500 kV transmission line called the Sunrise Powerlink (SRPL) that will connect the existing Imperial Valley substation, near El Centro, California to a new “Central” substation located in a central part of San Diego County.

The proposed path for the Sunrise Powerlink would be in the same right of way as Imperial Valley - Miguel line for approximately 4 miles. This route would contain approximately 12 towers. Figure 1, displays the proposed path as well as alternative path. The alternative path analysis is presented in Appendix F.

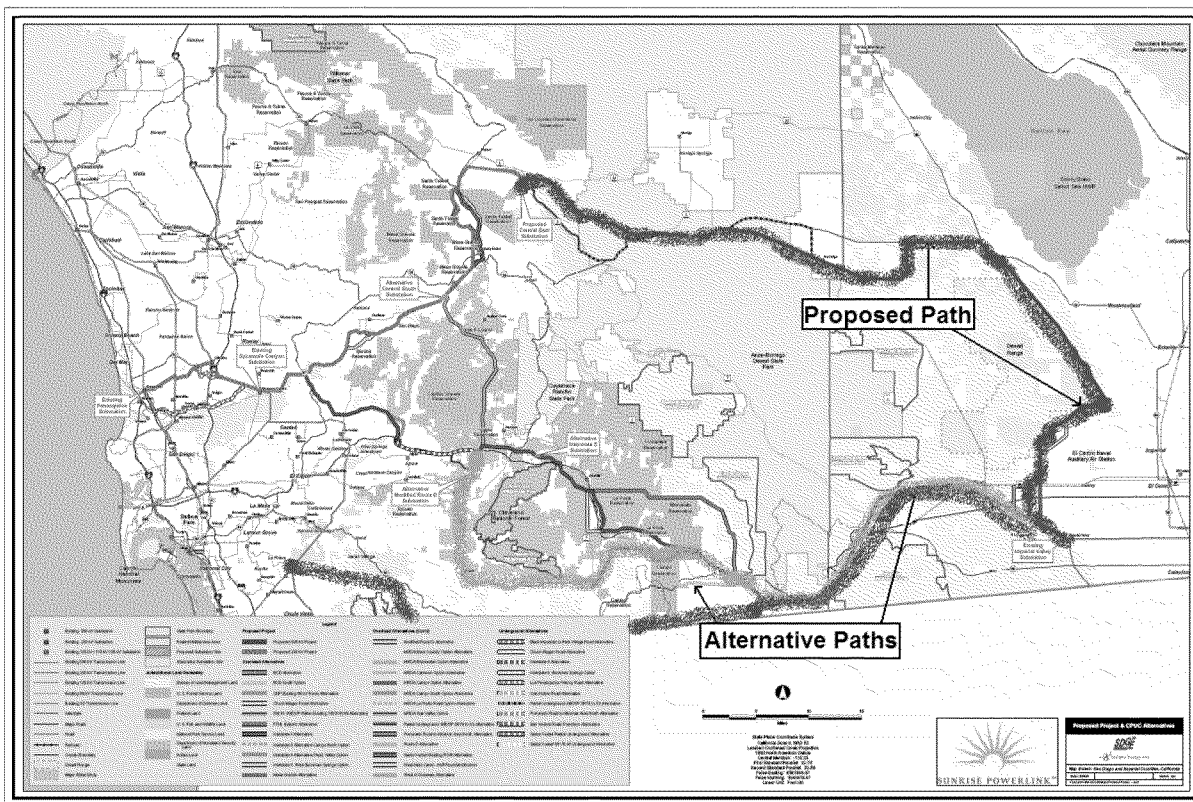

Figure 1: Proposed and Alternative Paths Map

Appendix A4 shows each individual tower, Towers 50281 – 50270, of the existing Imperial Valley - Miguel 500 kV line for the proposed path.

Within this right of way SDG&E is aware of a proposed 230 kV generation interconnection at the Imperial Valley substation. This generator interconnection would include a 230 kV line being placed in the same right of way as the two 500 kV lines. At this time SDG&E does not have the final design aspects of this generator interconnection to determine the exact design detail for the right of way positioning of the new 230 kV and 500 kV transmission structures.

Regardless, SDG&E would ensure that adequate right of way is obtained such that the towers are designed to prevent one tower from falling into an adjacent tower. More information on the potential spacing of towers can be found in Section 4, R2. Currently SDG&E anticipates that the generation interconnection line would interconnect to the Imperial Valley substation and be physically located past the take off for the proposed path. This illustration can be seen in Figure 2.

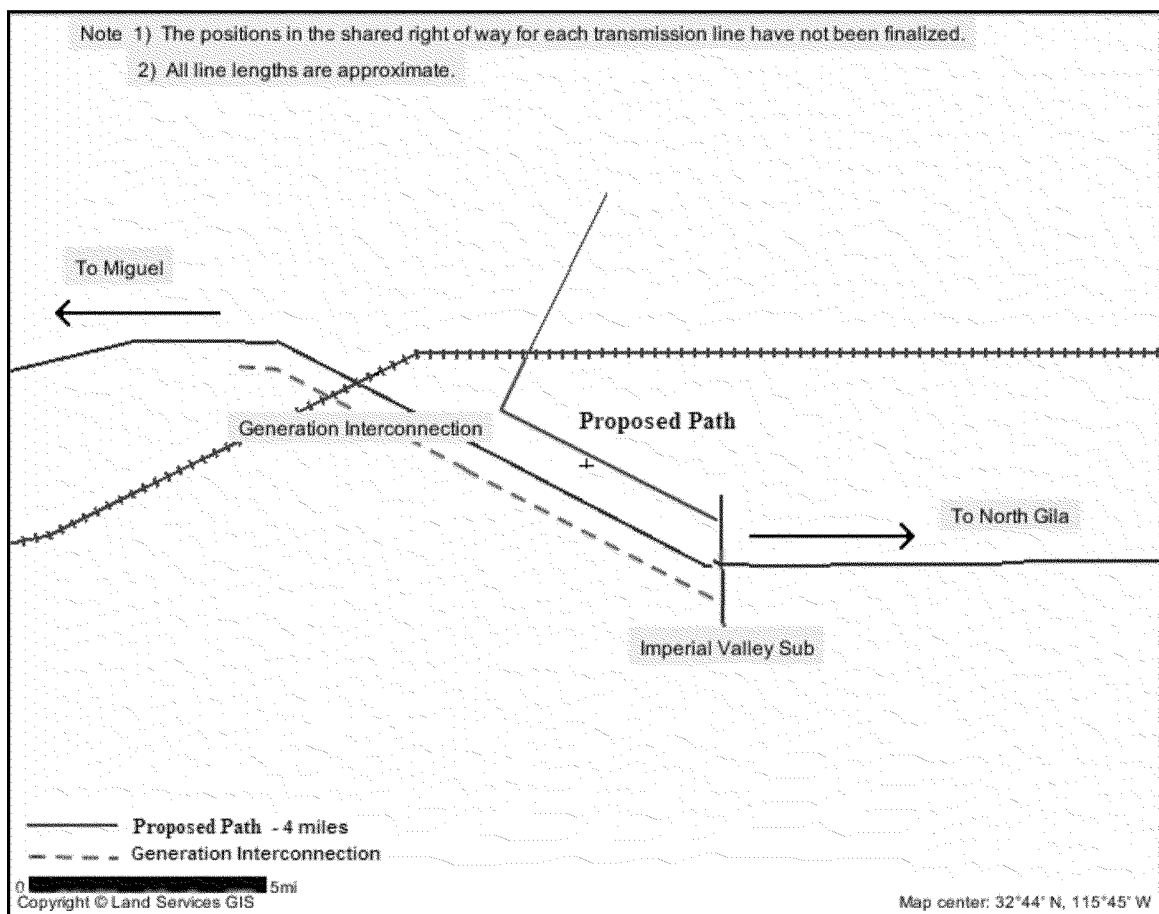

Figure 2: Potential Shared Right of Way Diagram

The following is a description of the existing Imperial Valley - Miguel 500 kV line. The proposed Imperial Valley - Central 500 kV line design has not been finalized. However,

the new line will be built, at a minimum, with the same characteristics as the existing Imperial Valley - Miguel 500 kV line.

The Imperial Valley - Miguel 500 kV line is approximately 80 miles long and is constructed of twin bundled 2156 ACSR/AW (Bluebird/AW) conductors in a horizontal bundle with 18" separation. The Imperial Valley - Miguel 500 kV line is constructed with lattice towers, with spans ranging from 411 feet to 1945 feet. The towers span an average distance of 1651.13 feet apart. Within the shared path, the tallest tower is tower number 50280, which serves as a tangent tower with a height of 146 feet. A tangent tower, also known as a suspension tower, is where the conductors are simply suspended from the tower, and have the same mechanical tension on each side. The shortest tower is tower number 50281, which serves as a dead-end tower at a height of 95 feet. The structures utilize two overhead shield wires. The size of the overhead shield wire is dependent upon the loading area the line is traversing. A 7 No. 8 Alumoweld is used in light loading areas. A 7 No. 6 Alumoweld is used in heavy loading areas. There is one transposition in the shared right of way and it is located on the second and third structures west of the Imperial Valley substation.

The length of the Imperial Valley - Central 500 kV line has not been finalized because the final route selection has not been completed. However this line is anticipated to be shorter than the existing Imperial Valley - Miguel line. The new line will be constructed with a three bundle 1033.5 kcmil ACSR/AW (Ortolan) conductor. The tower structures will also utilize two overhead shield wires.

The Imperial Valley 500kV bus is designed to operate as breaker-and-half, in ultimate configuration. Currently, the bus is being operated as a ring bus. When the new 500kV Sunrise Powerlink line is installed the bus will be reconfigured to operate as a combination breaker-and-half and double-breaker-double-bus. This configuration will increase the bus reliability in a stuck breaker contingency. For a single breaker failure to take out both 500 kV lines under either configuration, there would need to be a breaker out for maintenance followed by a breaker failure.



Figure 3: Imperial Valley substation

The existing Imperial Valley - Miguel line is protected by three primary-grade, piloted protection systems. The following equipment is used: 1) SEL-421 distance / over-current relays communicating over power line carrier, using three-phase Mode 1 coupling. The power line carrier transmit/receive equipment is RFL-9780; 2) GE L-90 line differential/distance/over-current relays communicating over digital microwave; and 3) SEL-311L line differential/over-current relays communicating over digital microwave. In addition, transfer trip is provided using RFL-9780 (power line carrier) and RFL-9745 (microwave) teleprotection units.

At this point, SDG&E anticipates a similar protection scheme for the Imperial Valley - Central 500 kV line as discussed above, with the understanding that communication options are still under discussion. The three protective relays described above would be applied, and two diverse communication paths would be incorporated, with power line

carrier, digital microwave and fiber optic being the communication systems under discussion.

The Miguel substation terminates the SWPL 500 kV line with two 500/230 kV transformers. The Miguel 500 kV substation is currently configured as a ring bus. Therefore, a fault on either Miguel transformer would not take out the Imperial Valley - Miguel line.

The proposed configuration for the Central 500 kV substation would be similar to the Miguel substation with a ring bus and two 500/230 kV transformers. Again, a fault on either Central transformer would not cause an outage on the Imperial Valley - Central line.

The towers are designed for conservative weather related loads and employ overhead ground wires for lightning protection. The towers proposed for the Imperial Valley - Central 500 kV line will be similar to the existing towers used on the SWPL. Pictures of all the existing SWPL towers for the proposed path can be found in Appendix A4.

The proposed path for Imperial Valley – Central would be in the same right of way as the Imperial Valley – Miguel line for a distance of 4 miles. The towers would be tangent and dead-end towers. The equivalent tower numbers on the Imperial Valley - Miguel line are 50270 thru 50281. Within this option there would be one dead-end tower coming out of Imperial Valley and the remaining eleven towers would be tangent towers.

As previously mentioned, there also is a possibility that a generation interconnection would be included in the shared right of way. This would add a 230 kV line in the right of way. It is anticipated that the 230 kV line would use a steel pole instead of a lattice tower. This pole would be approximately 150 feet in height.

It is anticipated that the line will contain a 90/10 layout, with 90% of the towers being tangent and 10% being dead-end. Tangent towers have no turn angles. They tend to be more slender than full tension dead-end towers. These towers typically may have an insulator string hanging down from the tower for each conductor, or two strings making a “V” shape. These towers are used when a transmission line continues in a straight line, or turns through a small angle. In other cases a dead-end is used.

Dead-end towers are typically built stronger and have a wider base as well as stronger insulator strings. They are used in areas where a transmission line ends or turns into a large angle. On the other hand, angle towers have light or heavy turning ability. Angle towers would be used at locations where the transmission line direction would change.

The V-string insulator assembly is typically used for suspension of insulator strings carrying up to four bundled conductors per phase. The V-strings tend to be more efficient than the vertical strings due to their self-cleaning aspect. During rain showers, the rain will hit both sides of the insulators allowing contaminants to be easily removed. The V-string tangent assembly is composed of a string of 31 porcelain suspension

insulators. In some situations a strain or I-string jumper might be used. A strain assembly would use 32 insulators per string and an I-string jumper would use 36 insulators per string. All hardware will be corona-free and corona rings will be installed on all assemblies.

All transmission lines are on a three year land patrol schedule. There are two aerial patrols as well as additional special aerial patrols that are also conducted per year. Typically one aerial patrol is visual, one patrol utilizes infrared detection equipment, and three additional special patrols a year are for security purposes.

SDG&E's Vegetation Management Program conducts annual inspections, ground or air, to identify any vegetation conflicts along all transmission circuits. Minimum clearances between vegetation and conductors, based on voltage, are maintained to comply with applicable rules and regulations including CPUC General Order 95 and Public Resource Code section 4293 and 4292². Excerpts from the codes can be found in Appendix B.

Step 2. Outage Database - The Sample

The Southwest Powerlink (SWPL) is SDG&E's only 500 kV transmission line, therefore outage data was collected on the Imperial Valley - Miguel portion of SWPL. The outage data was reviewed to determine outages that occurred on the portion of the Imperial Valley - Miguel line that is proposed to share a common right of way with the Imperial Valley - Central 500 kV line. With thirteen years of outage data (1995 - 2007) available, SDG&E concluded that of the 44 forced outages on the Imperial Valley - Miguel line there was only one event that occurred on the proposed shared right of way during these years. This was caused by the washing of insulators on the line. Therefore it can be concluded that this event would not be a factor in the double line outage analysis because the two adjacent lines would not be washed simultaneously.

The majority of the forced outages that took place on the Imperial Valley - Miguel 500 kV line were fire related outages. These were primarily due to the surrounding vegetation on the central and western portions of the line, which are prone to fires. This is in stark contrast to the eastern portion of this line because all of the proposed shared right of way is desert terrain with sparse vegetation. This is clearly seen in Appendix A4 when looking at the surrounding terrain of the transmission towers. Various groups within SDG&E continue to work with outside parties in order to help minimize the frequency of fires along the SWPL right of way.

Concerning lightning related outages, SDG&E is working to implement solutions to decrease the number of outages may be seen on the Southwest Powerlink. This includes the installation of an overhead ground wire on the Sunrise Powerlink to reduce lightning strike outages.

² CPUC General Order 95 and Public Resource Code Section 4293 and 4292, *California Law*, Available at. Accessed 6/2/2006. Page 33

SDG&E's system has only one 500 kV line, SWPL. In consideration of this fact, SDG&E determined that using historical 500 kV data from the Palo Verde Hub to North Gila Performance Category Upgrade Request report by Arizona Public Service (APS) would be appropriate. This is because APS's request for the Palo Verde Hub to North Gila line is actually the eastern portion of the Southwest Powerlink and the terrain is quite similar in that it is desert terrain. The Performance Category Upgrade Request for Palo Verde Hub to North Gila Lines was officially approved by the WECC Board of Directors in December 2006.

The following portions in this report have been referenced from the report published by APS³. Permission to use the following data was obtained from APS prior to publishing SDG&E's report. To benefit those reviewing this report SDG&E has included portions of the APS report as it relates to the outage database sample. This data was included due to the applicability of the data to the Imperial Valley - Miguel line that is of similar construction to the Palo Verde to North Gila line. The portions of the APS report are signified by italics.

Step 2: Outage Database – The Sample

Because the subject line has not yet been built, a set of data for operation of two parallel lines along the corridor of interest is not available. Over twenty years of historical outage data of the single Hassayampa – North Gila 500 kV line is available but this outage data is not useful in calculating the probability of having two lines in the same corridor concurrently out. Although outage data for the proposed line configuration is not available, APS has a fair amount of data on parallel lines that use the same basic transmission structure. Table 1 gives a listing of double circuit 500 kV lines in common corridors for which outage data is available. In this table it is seen that three sets of lines have over 10 years worth of data, two sets of lines have 9 years of data, and three sets of lines have 3 or 4 years of data.

³ “Performance Category Upgrade Request For Palo Verde Hub to North Gila Lines”, April 2006, Arizona Public Service Company. Pages 9-16

Table 1: Listing of 500 kV Lines Sharing Common Corridor			
Line 1	Line 2	Common Miles	Years of Data
Navajo – Westwing	Navajo – Moenkopi	76	20
Navajo – Westwing	Moenkopi – Westwing	180	11*
Navajo – Westwing	Yavapai – Westwing	101	9*
Navajo – Westwing	Moenkopi – Yavapai	79	9*
Palo Verde – Westwing #1	Palo Verde – Westwing #2	45.1	13
Palo Verde – Hassayampa #1	Palo Verde – Hassayampa #2	3	4
Palo Verde – Hassayampa #2	Palo Verde – Hassayampa #3	3	4
Redhawk – Hassayampa #1	Redhawk – Hassayampa #2	1	3

*The data on these lines runs from 1984 – 2004. However, in early 1996 the Yavapai substation was installed which split the Moenkopi – Westwing line into two segments. So of the data, 11 years covers the time with the line from Moenkopi – Westwing, and 9 years cover the time with this line split into the Moenkopi – Yavapai, and the Yavapai – Westwing lines.

Pertinent information regarding how applicable the line data is to the subject lines is given as follows:

1. The Navajo – Westwing line and the various lines that parallel it on its path (Navajo – Moenkopi, Moenkopi – Yavapai, Yavapai – Westwing lines) are very similar in construction to the Hassayampa – North Gila line and its proposed parallel twin. The structures are the same design and the wire size, span lengths and right-of-way separation are all similar. The major differences between this set of lines and the Hassayampa – North Gila lines is the terrain, vegetation, elevation, and weather conditions along the different line routes. The Navajo – Westwing line starts at an elevation between 5000 and 6000 feet at Navajo. As the line moves south it traverses high desert plateau until it reaches the heavily forested area in central Arizona. The elevations in these areas exceed 7000 feet. As the line moves further south the line continues through significant forest areas until it drops in elevation near Phoenix. The last 20 miles or so of the line have similar terrain to the North Gila line. Because the majority of the Navajo – Westwing line is located at significantly higher elevations than the North Gila line route, more exposure to outages is expected in terms of outages due to lightning, fire, and weather. Thus any statistics generated based on the outages of the lines along the Navajo – Westwing 500 kV line route would be expected to be conservative compared to statistics along the Hassayampa – North Gila line route. The multiple years and multiple miles worth of data makes these outage statistics desirable for use in the outage database with the understanding that some outages may not be appropriate to count.

2. The two Palo Verde – Westwing 500 kV lines traverse terrain that is similar to the North Gila line route and would have similar outage statistics for outages attributed to line route characteristics. The

construction of the line is slightly different from that on the existing North Gila line with some structure and wire differences. The 13 years worth of data makes this set of outage data applicable for the outage calculations.

3. The two Redhawk – Hassayampa lines are similar in construction, terrain, and elevation to the Hassayampa – North Gila lines. Only 4 years of data are available on this set of lines and the short line length tends to reduce the outage exposure. These lines are included in the database.

4. The parallel lines from Hassayampa to Palo Verde are somewhat similar to the North Gila lines in most aspects. There are some differences however including the following:

a. There are three parallel lines from Palo Verde to Hassayampa. Consequently, the outage of the two sets of lines that directly parallel each other are used in the statistics database. Common outages of the two outside lines in the corridor (Lines 1 and 3) are not used because their separation distance is significantly different from the proposed lines.

b. The structures are slightly different from the North Gila line structures as are the wire sizes and configuration.

c. The line lengths are very short compared to the North Gila line(s) so exposure to environmentally based outages will be less than for the subject lines.

Despite the various differences between the lines in Table 1 and the proposed parallel Hassayampa – North Gila lines, all of the outage data is used in the base case uncorrected outage database. Outages that are included are those outages where both lines trip essentially simultaneously or within a time frame that the operators would not have been able to adjust schedules in anticipation of a second contingency. A 30 minute time frame is assumed to be needed for the operators to prepare for another outage. Instances where a line is out on maintenance and the other line trips are not counted in the database. Planned maintenance outages are also not counted in the database.

Table 2 gives a listing of the simultaneous outages for the lines listed in Table 1 over the study period. This set of data is used for the unadjusted data sample in the mean time between failures (MTBF) calculation.

Event #	Line Name	Out Date/Time	In Date/Time	Event Category	Overlap (Hr:min)	Comment
1	PLV-WWG1	6/14/2004 7:41	6/14/2004 8:17	System	00:36	Substation Related
	PLV-WWG2	6/14/2004 7:41	6/14/2004 8:18			
2	PLV-HAA #1	6/14/2004 7:41	6/14/2004 8:09	System	00:28	Substation Related
	PLV-HAA #2	6/14/2004 7:41	6/14/2004 8:11			
3	PLV-HAA #2	6/14/2004 7:41	6/14/2004 8:11	System	00:30	Substation Related
	PLV-HAA #3	6/14/2004 7:41	6/14/2004 8:11			
4	NAV-WWG	8/10/1996 15:48	8/10/1996 17:04	System	01:15	System Event
	NAV-MKP	8/10/1996 15:48	8/10/1996 17:03			
5	NAV-WWG	4/15/1996 4:32	4/15/1996 7:09	Terminal	02:35	Substation Related
	NAV-MKP	4/15/1996 4:37	4/15/1996 7:12			
6	WWG-YAV	6/14/2004 7:40	6/14/2004 8:21	System	00:40	Substation Related
	NAV-WWG	6/14/2004 7:41	6/14/2004 8:23			
7	NAV-WWG	7/2/2004 14:58	7/2/2004 15:01	Line	00:02	Fire
	WWG-YAV	7/2/2004 14:58	7/2/2004 15:00			
8	NAV-WWG	7/2/2004 15:03	7/2/2004 19:52	Line	00:03	Fire
	MKP-YAV	7/2/2004 15:07	7/2/2004 15:11			
9	NAV-WWG	7/2/2004 15:03	7/2/2004 19:52	Line	04:23	Fire
	MKP-YAV	7/2/2004 15:25	7/2/2004 19:49			

Step 3. Mean Time Between Failure Calculation

Given that SDG&E proposes to use the same outage data as in the APS report, SDG&E will also reference the applicable calculations in the APS report. Due to the fact that SDG&E has no parallel line data, SDG&E will utilize APS's historical events analysis. Given the regional similarities, SDG&E believes this data is applicable for this analysis.

Part 1: MTBF Unadjusted Sample Calculation:

The following MTBF analysis is based on the outage data on all the 500 kV lines in the APS system that has common corridor parallel lines. It does not take into account differences between the North Gila line corridor and the other corridors in the statistical database or any mitigating factors. Part 2 of the analysis will take into consideration these differences.

Historical Events

Terminal Caused (See Event #5 in Table 2):

P_T = frequency of terminal caused events

The number of terminal years in the historical event analysis is given by the following table:

Terminal	Corridor	Years
WWG	NAV	20
	PLV	13
PLV	WWG	13
	HAA	4
HAA	PLV	4
	RW	3
RW	HAA	3
NAV	WWG	20
Total =		80

$$P_T = (2 \text{ NG Line Terminals})(1 \text{ event})/(80 \text{ terminal-years}) = 0.025 \text{ events/year}$$

Line Caused (See Events # 7, 8, 9 in Table 2):

$P_L = \text{frequency of line caused events}$

$$P_L = (3 \text{ events})(117 \text{ miles})/(5733 \text{ mile-years}) = 0.0612 \text{ events/year}$$

System Events (See Events #1, 2, 3, 4, 6 in Table 2):

System events are those major events where the initiating event has widespread effect which is often cascading in nature. These types of events are initiated by problems not directly tied to the lines of interest although the lines of interest are affected by the resulting events. Often the statistics can be skewed significantly by system events which trip multiple lines for a single event. The statistics database has two such system wide events which account for five of the nine common corridor outages in Table 2. System events are not included in the probability calculation.

SDG&E Independent Events

The following calculation is to determine the probability of having both the Imperial Valley - Miguel and the Imperial Valley - Central 500 kV lines trip out independently at the same time. Older outages that were caused by substation equipment which would not cause line outages today have been excluded in the forced outage data. Historical Imperial Valley - Miguel 500 kV line outage statistics are as follows:

Forced Outages: 44 (1995-2007)

Average Outage Duration: 302.7727 minutes

forced outages/year = 3.3846

$P_{Ind} = \text{Frequency of outages of Imperial Valley - Miguel and Imperial Valley - Central lines due to independent events}$

This statistic is given by the following equation:

$$P_{\text{Ind}} = (\text{Probability Line 1 is out}) * (\text{Frequency of Line 2 outage}) + (\text{Probability Line 2 is out}) * (\text{Frequency of Line 1 outage})$$

Assuming the same statistics for both lines is a conservative estimate, the new Imperial Valley - Central 500 kV line is expected to have a shorter length than the Imperial Valley - Miguel 500 kV line:

$$P_{\text{Ind}} = 2[(\text{Avg number of outages/year}) * (\text{Avg Outage Duration}) / (\text{\# of mins/year})] * (\text{Avg number of outages/year})$$

$$P_{\text{Ind}} = 2[(3.3846 \text{ outages/year}) * (302.7727 \text{ min/outage}) / (525600 \text{ min/year})] * (3.3846 \text{ outages/year})$$

$$P_{\text{Ind}} = 0.013198 \text{ outages/year}$$

Human Caused Errors

While APS may experience human caused errors that trip lines, the outage database does not show any human caused errors which tripped more than one line out of a 500 kV substation. For the data in the database, there are the following number of years of data and possible combinations of lines emanating from the station taken two at a time:

Terminal	Lines Emanating	Combinations	Years in DB	Yrs X Comb
PLV	7	21	13	273
HAA	10	45	4	180
WWG	4	6	20	120
NG	2	1	13	13
NAV	3	3	20	60
MKP	4	6	20	120
YAV	2	1	9	9
Sum		83		775

$P_H = \text{Frequency of human caused double line outage}$

One can assume that the probability of tripping both lines due to a human caused error is less than the following:

$$P_H < (1 \text{ event combination}) / (775 \text{ years-combinations})$$

$$P_H < 0.00129 \text{ events/year}$$

SDG&E will use this value for the uncorrected sample.

Breaker Maintenance

The breaker maintenance program typically plans for minor maintenance one day every two years and for major maintenance five days every ten years. These are scheduled when the system impact risk is not present. Therefore, SDG&E conservatively predicts that each breaker will be out for two days each year with the inclusion of unexpected outages. Based on the CIGRE (International Council on Large Electric Systems) breaker failure statistics, a breaker failure event occurs once per 479 years⁴. The estimated probability of a breaker failure occurring during the two day maintenance period considering the four combinations that are possible is:

$$P_B = (2 \text{ days}/365 \text{ days/year}) (4 \text{ combinations}/479 \text{ years}) = 0.0000458 \text{ events/year}$$

MTBF – Summary of Uncorrected Results

Summary of Results (Uncorrected)			
	Event Cause	P (events/year)	MTBF (years)
P_T	Historical Terminal	0.0250	40.0000
P_L	Historical Line	0.0612	16.3399
P_{IND}	Independent	0.0132	75.7687
P_H	Human	0.0013	>775
P_B	BF & M	0.0000458	21854.3750
P_{TOTAL}	Total	0.1007	9.9272

Table 1 - MTBF Uncorrected

Uncorrected Confidence Interval:

Confidence Intervals were asked to be calculated as previously referenced in the Seven Step Process for Performance Category Upgrade. Confidence intervals are typically used to indicate the reliability of an estimate. In this case, a 95% confidence interval would indicate that the calculated values are 95% reliable. The confidence interval was calculated by multiplying the Uncorrected MTBF by confidence interval factors shown in Appendix D.

95% Confidence Level:

Lower Limits:

44 failures: 0.7447

Upper Limits:

44 failures: 1.3767

³ CIGRE Study Committee 13 Report as referenced in “Kangley – Echo Lake Double-Line Outage Probability Analysis” report, May 28, 2002, Bonneville Power Administration.

$$\begin{aligned} \text{MTBF}_{\text{lower}} &= .7447 * 9.9272 \\ &= 7.3930 \end{aligned}$$

$$\begin{aligned} \text{MTBF}_{\text{upper}} &= 1.3767 * 9.9272 \\ &= 13.6671 \end{aligned}$$

As shown below in Table 2, values were calculated for the various confidence intervals to show a potential range of values.

Uncorrected Confidence Interval		
Confidence Interval	MTBF _{lower}	MTBF _{upper}
95%	7.3929	13.6671
90%	7.7241	12.9226
80%	8.1313	12.1274
60%	8.6638	11.2479

Table 2: Uncorrected Confidence Interval

Part 2: MTBF Calculation – Corrected

The Part 1 uncorrected MTBF calculation shown in Tables 1 and 2 is based on all of the available statistical data for common corridor lines and does not take into account differences between the corridors in the database and the shared right of way. This part of the analysis will correct the MTBF calculation to account for those differences.

SDG&E will provide the relevant sections from the APS report and again, these sections are denoted in italics.

Historical Outages

Terminal Related Outages (Pr):

Only a single common corridor double line outage is found in the database that is terminal equipment related (Event 5 in Table 2). The equipment involved was communication equipment used by the line relaying. Power supply problems at one of the communication sites caused low voltage on the analog microwave equipment. Because the communication system was analog, this low voltage to the microwave 18 equipment caused excessive noise on the communication channels. The line relaying being used at the time was susceptible to improper tripping due to noise on the communication channels and this noise (due to sagging voltage on the microwave equipment) is what eventually caused both lines to trip. Since this event occurred, several improvements to the system have occurred which eliminate the possibility that an event like this could happen on the North Gila lines. These improvements include:

1. *The microwave system has been upgraded to a digital system. Consequently, voltage sags or reductions will not cause noise on the communication path.*
2. *The relaying used is a digital relaying system that is not susceptible to false tripping for loss of the communication signal. The protection systems require communication from both line ends to produce a trip so loss of communication or noise on the communication system will not inadvertently produce a line trip. One might lose one of the protective schemes but a false trip will not be produced.*
3. *Use of fiber optic communications for some of the relaying in the new line.*

Because of these differences and improvements between the new line communication systems and the systems in service at the time of the outage event, this particular historical terminal related outage event is not credible for the North Gila lines. Consequently, the terminal related outage probability in the corrected sample should be based on zero incidents. However, with zero applicable incidents over the past 20 years, a true measure of the outage frequency due to terminal related outages is not possible. Instead, one can only calculate a range within which the outage frequency will fall. The optimistic bound of the range will be based on using zero in the statistical formula, and the pessimistic bound based on assuming 1 terminal related event in the formula. Thus,

$$P_{Topt} = (0 \text{ events})(2 \text{ terminals}) / (80 \text{ terminal-years}) = 0 \text{ outages/year}$$

$$P_{Tpes} = (1 \text{ events})(2 \text{ terminals}) / (80 \text{ terminal-years}) = 0.025 \text{ outages/year}$$

$$0 < P_T < 0.0125 \text{ outages/year}$$

From a substation terminal point of view, the second line to North Gila will be built as though it were an independent line, with separate and independent relaying, communication, and terminal connections in a breaker-and-a-half scheme. No common mode failure mechanisms are identified. As a consequence, it is believed that the outage frequency due to terminal related causes will be closer to zero.

SDG&E's protective relaying is designed and tested to minimize risk of sympathetic tripping. The existing Imperial Valley - Miguel 500 kV line is protected by three primary-grade, piloted protection systems. The following equipment is used: 1) SEL-421 distance / over current relays communicating over power line carrier, using three-phase Mode 1 coupling. The power line carrier transmit/receive equipment is RFL-9780; 2) GE L-90 line differential / distance / over-current relays communicating over digital

microwave; and 3) SEL-311L line differential / over-current relays communicating over digital microwave. In addition, transfer trip is provided using RFL-9780 (power line carrier) and RFL-9745 (microwave) teleprotection units.

At this stage of design for the Imperial Valley - Central 500 kV line, SDG&E plans to install the same protection scheme as given above, with the understanding that communication options are still under discussion. The three protective relays mentioned above will be applied, along with two diverse communication paths being incorporated. Power line carrier, digital microwave and fiber optic communication systems are under discussion.

There have been two potential terminal events that have occurred on the Imperial Valley – Miguel 500 kV line. One event that occurred was in June 2002, due to a relay crew inadvertently tripping a transformer via a fault relay. Due to the differences between SDG&E’s protective relaying system presently in place on the Imperial Valley - Miguel line and that which was in service at the time of the outage event, this particular historical terminal related outage event is not credible for SDG&E’s lines.

Another event that occurred was due to a relay crew shorting out a current transformer at Imperial Valley substation causing TL 50001 to trip. Since relay crews will not be working on both lines simultaneously, it would not be possible for the crews to short out current transformers on both lines at once. Therefore, the terminal related outage probability in the corrected sample for SDG&E should be based on zero incidents.

$$P_T = 0$$

Line Related Outages (PL)

The list of historical outages contains 3 events where line faults tripped both lines in a common corridor. All three of these outages involved forest fires in an area of the state that is heavily forested. The differences in corridor vegetation characteristics should be taken into account for the corrected sample and details of the specific outages will be examined.

Event #7 in Table 2 involved a forest fire that occurred when fire fighters were conducting a controlled burn that got out of hand in a heavily forested area of the state. The fire tripped one line and an inappropriate relay action tripped the second line. The relay’s settings were subsequently altered to prevent future relay misoperation for a fault on the other line. Because the initiating fault was due to a fire started for fire suppression purposes this event is discounted. The area where the fire occurred was in a heavily forested portion of the state where special fire fighting methods (controlled burns) are done to manage the growth. The North Gila line corridor is sparsely vegetated with no forest or any other special fire fighting methods needed. The

Robust Line Design section (Step 4) of this report shows that the North Gila corridor is in a low fire risk area of the state whereas the location of this outage was in a high risk area. Consequently this outage should be discounted from the database of outage events.

Outages #8 and #9 in Table 2 occurred shortly after Outage #7 and occurred due to the same firefighting controlled burn. This time two lines tripped due to the fire. In Outage #8, the lines didn't trip at the same time but one line followed the other after a delay of 4 minutes. Again, the corridor differences and the fact that controlled burns are not done along the North Gila line corridor would make this outage not applicable to the North Gila line corridor. Outage #9 occurred when operators attempted to place back in service one of the two lines which was out from Outage #8. The line tripped out again due to the fire. This outage is discounted due to the same reasons as stated for Outages #7 and #8.

For the above reasons, none of the line related common corridor double contingency outages should be counted in the corrected MTBF calculation. Elimination of the three incidents in the database, again makes the actual line related outage frequency statistic unknown for the subject line. The best that can be stated with surety is that the statistic is bounded by the assumption of 0 outages and 1 outage in the statistical formula. This gives the following result:

$$P_{Lopt} = (0 \text{ events})(117 \text{ miles})/(5733 \text{ mile-years}) = 0 \text{ outages/year}$$

$$P_{Lpes} = (1 \text{ events})(117 \text{ miles})/(5733 \text{ mile-years}) = 0.0204 \text{ outages/year}$$

$$0 < P_L < 0.0204 \text{ outages/year}$$

The expected line related outage frequency statistic is believed to be significantly lower than the pessimistic bound calculated above and will most likely approach the independent event outage statistic. This belief is based on the robust line design issues addressed in Step 4 of this report.

As was stated previously in this report, the shared right of way between the Imperial Valley - Miguel and Imperial Valley - Central lines is desert terrain. The Robust Line Design section (Step 4) of this report shows that the shared right way is in a low fire risk area, whereas the outages in APS's data were in a high risk area. Therefore, none of the line related common corridor double contingency outages should be counted in the corrected MTBF calculation.

$$P_L = 0$$

Independent Event Calculation (P_{Ind})

The probability that the Imperial Valley - Miguel and Imperial Valley - Central lines trip simultaneously from independent events is corrected because a 30 minute time frame is assumed to be the length of time needed for the operators to prepare the transmission system for the next outage. This is reasonable to assume in that this probability is meant to calculate the probability that outages occur simultaneously and that the transmission system would not be able to be readjusted between the times of the two outages. For example, if a line was forced out of service for more than 24 hours, operators would adjust the power system within 30 minutes to make the system reliable until the line is returned to service. It would be only during the first 30 minutes that the system would be at risk from the effects of “simultaneous” outages from independent events. Therefore, SDG&E’s P_{Ind} calculation with outages greater than 30 minutes corrected is as follows:

Forced Outages: 44 (in 13 year period)
Avg Outage Duration: 23.6820 minutes
forced outages/year = 3.3846

P_{Ind} = Frequency of outages of Imperial Valley - Miguel and Imperial Valley - Central lines due to independent events

This statistic is given by the following equation:

P_{Ind} = (Probability Line 1 is out)*(Frequency of Line 2 outage) + (Probability Line 2 is out)*(Frequency of Line 1 outage)

Assuming the same statistic for both lines, (which is a conservative estimate since the new Imperial Valley - Central 500 kV line is expected to have a shorter length than the Imperial Valley - Miguel 500 kV line and will be in similar terrain):

P_{Ind} = 2*[(3.3846 outages/year)*(23.6818 min/outage) / (525600 min/year)] * (3.3846 outages/year)

P_{Ind} = 0.0010 outages/year

Breaker Failure and Maintenance Calculation (P_B)

The calculation of the probability of a breaker failure event while one of the line breakers is out for maintenance does not change for the corrected MTBF calculation. It is recognized that breaker maintenance is usually scheduled for a time where system conditions limit the risk of adverse consequences.

P_B = 0.0000458 events/year

Human Cause Failures (P_H)

This statistic would be the same as for the uncorrected data.

$$P_H = 0.0013$$

MTBF – Summary of Corrected Results

The corrected calculation of MTBF is shown below in Table 3. The reason that there are two sets of values for the MTBF, is because there is not enough data to calculate definite values. The MTBF₁ is the upward bound value and MTBF₂ is the lower bound value. SDG&E feels that after reviewing the data from the Robust Line Design, the MTBF will tend towards the upward bound value.

Summary of Results (Corrected)					
	Event Cause	P ₁ (events/year)	MTBF ₁ (years)	P ₂ (events/year)	MTBF ₂ (years)
P _T	Historical Terminal	0	0	0.025	>40
P _L	Historical Line	0	0	0.0204	>49
P _{IND}	Independent	0.0010	968.7053	0.0010	968.7053
P _H	Human	0	0>	0.0013	>775
P _B	BF & M	0.0000458	21854.375	0.0000458	21854.375
P _{TOTAL}	Total	0.0011	927.5895	0.0478	20.9301

Table 3: SWPL/SRPL MTBF Results

The calculated MTBF for the corrected dataset is 928 years. This level is significantly larger than that needed for Performance Level D of the Performance Based Reliability Criteria.

Corrected Confidence Interval:

Confidence Intervals were asked to be calculated as previously referenced in the Seven Step Process for Performance Category Upgrade. They are typically used to indicate the reliability of an estimate. In this case, a 95% confidence interval would indicate that the calculated values were 95% reliable. As can be seen below, in Table 4, the corrected confidence interval at 95% is above 300 years. This means that at a 95% confidence level, the MTBF will be between 690.7944 and 1277.049506. The lower and upper limits would still meet Category D requirements with allowed cascading. The confidence intervals for the remaining levels also meet Category D requirements with allowed cascading.

Corrected Confidence Interval				
Confidence Interval	MTBF _{lower1}	MTBF _{upper1}	MTBF _{lower2}	MTBF _{upper2}
95%	690.7944	1277.0495	15.5903	28.8213
90%	721.7388	1207.4803	16.2887	27.2513
80%	758.7496	1142.1594	17.1240	25.7771
60%	807.6150	1064.5759	18.2268	24.0261

Table 4: Corrected Confidence Interval

Step 4: Robust Line Design Mitigating Factors:

R1: Risk of fire affecting both lines

There have been no recorded weather-related incidents that have occurred on the proposed shared right of way. However, SDG&E has also reviewed the incidents that occurred on the line but outside of the shared right of way. There have been thirty weather related incidents that have occurred in this area. Out of these thirty incidents, five were caused due to lightning. The other twenty five were fire related incidents. The reason behind the fire related incidents is that the eastern and central portion of the line goes through highly vegetated areas. However, the proposed shared right of way is desert terrain, where there is a minimal chance of fires.

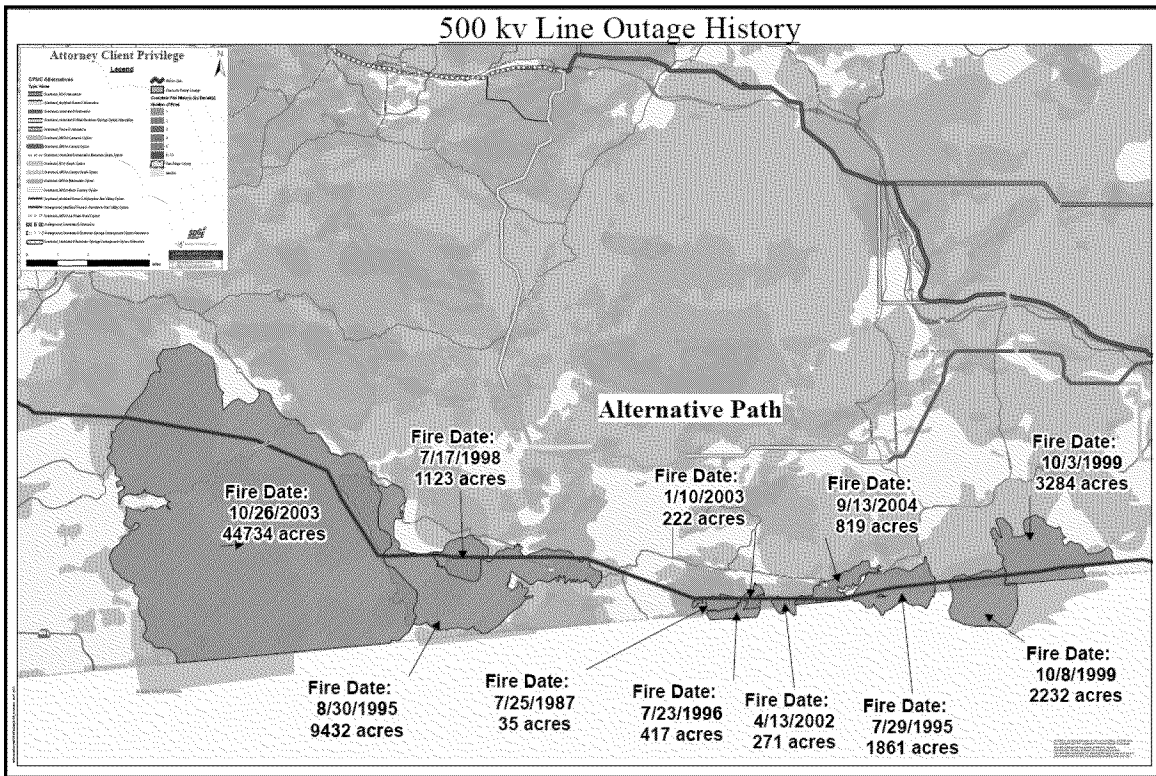

Figure 4: SWPL Fires

There has been twelve fire related events that have taken place in the eastern and central portion of the Imperial Valley – Miguel line. Figure 4 displays eleven of the twelve fire related events. An additional fire took place in October, 2007, that outaged the Imperial Valley – Miguel line. This fire related event is shown in Figure 14. The fire event on October 3, 1999 is the closest fire to the proposed path.

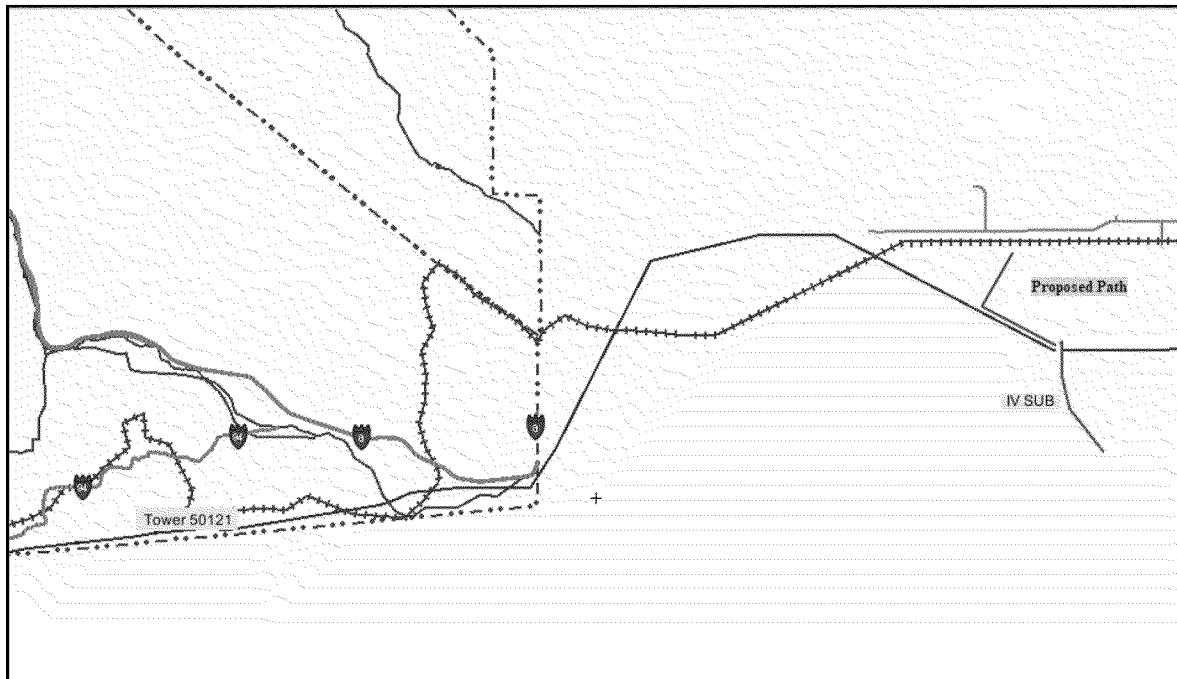

Figure 5: Closest Corridor Fire

The fire on October 3, 1999 occurred between tower 50121 and tower 50130. As one can see from Figure 5, the portion of the line affected by the fire is approximately 43 miles from the shared right of way. Also, as can be seen from Appendix A1, the area surrounding the Imperial Valley substation, which is where the line will be located, is not in a hazardous fire zone.

R2: Risk of one tower falling into another line

The risk of one tower falling into another line is not anticipated to be a factor due to the spacing of the lines. The centerline spacing between towers is currently anticipated to be at least 400 feet, which makes it impossible for one tower to fall into another, since the height of the tower is smaller than the distance between the lines. The heights of the towers range from 95 feet to 146 feet.

Within this shared right of way there is a possibility that a generation interconnection transmission line will also be installed. Below is a potential example of this configuration:

SRPL – 400 ft – SWPL – 150 ft – Generation Interconnection line

The Generation Interconnection is south of both 500 kV lines. The maximum tower height for SWPL and SRPL is 146 ft. Even if the SWPL tower fell toward the SRPL tower there would still be spacing between the two towers to avoid collision.

A diagram representing the tower spacing is shown in Appendix A2.

R3: Risk of a conductor from one line being dragged into another line

The risk of a conductor from one line being dragged into another line is similar to having an aircraft fly into both lines. This is an unlikely event because no flight related incidents that have occurred on the shared right of way in the past. Aerial marker balls have been installed on portions of the line, which serve as line detectors to warn pilots of the transmission lines. The lines also meet FAA criteria for height regulations. More information can be found on this subject in R5.

R4: Risk of lightning strikes tripping both lines

From SDG&E's data, there have been no known lightning strikes that have taken place within the proposed right of way. As stated previously in the report, the lightning density in the proposed shared right of way is relatively low with a density of 0 - 0.25 flashes/square km/per unit time.

The maps in Figures 6 and 7 represent the lightning flash density in California from 1989-1996⁵. The area marked IV (Imperial Valley) is where the corridor will lie. As shown, the IV area has 0 - 0.5 flashes/square km/year.

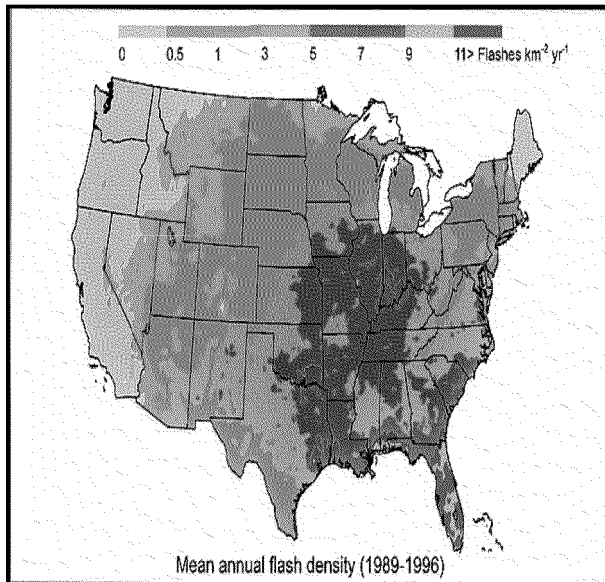

Figure 6: Flash Density (1989-1996)

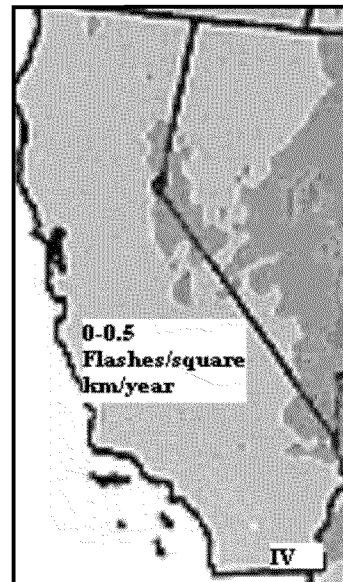

Figure 7: IV Flash Density (1989-1996)

⁵ American Meteorological Society, Available at <http://ams.allenpress.com/archive/1520-0450/38/7/figure/i1520-0450-38-7-1013-f01.jpg>. Accessed 4/26/2006. Page 22

The map shown in Figure 8 was referenced from the Palo Verde Hub to North Gila Lines Report created by APS⁶. Since this map shows lightning density from 1995-2004, it was also included. As one can see from Figure 8, the flash density is 0 - 0.25 flashes/square km/year.

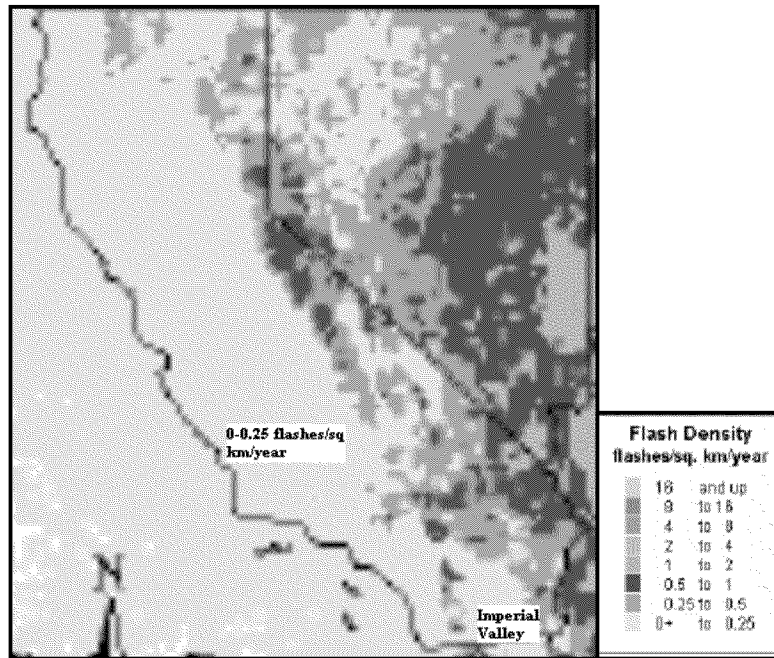

Figure 8: APS Flash Density 1995-2004

The flash density at Imperial Valley in either Figure 7 or 8 is the lowest flash density in comparison to the rest of the United States, making the probability of a lightning strike in the area low.

R5: Risk of an aircraft flying into both lines

There have been no flight related incidents that have occurred on the shared right of way. However, there have been two incidents on the Imperial Valley - Miguel line segment not sharing the proposed right of way involving an aircraft flying into the lines. Please note that these incidents occurred soon after the SWPL was built over 20 years ago and since that time SDG&E has worked to ensure additional incidents do not occur. The first incident occurred on the morning of June 14, 1985 when a Border Patrol pilot failed to gain altitude to clear the power lines, and crashed into the Imperial Valley - Miguel line. This incident took place only a year after the line was put in place. It occurred in Imperial County, 100 yards north of the Southern Pacific Railroad tracks.

⁶ "Performance Category Upgrade Request For Palo Verde Hub to North Gila Lines", April 2006, Arizona Public Service Company. Pages 9-16

The second incident occurred on October 24, 1988. This happened on a training flight during a joint drug interdiction mission. The helicopter snagged a power line while en route, and exploded into a hillside in western Imperial County. This incident occurred approximately four years after the line was put in service in 1984.

Airport Location: The Imperial County Airport is a small regional airport with feeder service into the Los Angeles International Airport. It is located approximately 4 miles north of downtown El Centro and 94 miles east of San Diego.

Military Airport Location: There is a military airport within Imperial, CA. The Naval Air Facility is 10 miles east of Imperial located in El Centro, CA. All military training is conducted within the confines of restricted airspace within which neither the SWPL or SRPL lie. Otherwise, military flight routes are generally conducted at high altitudes. However, military helicopters may fly at lower altitudes and do not adhere to any specific flight route. SDG&E foresees a low probability of an incident occurring because of the aerial marker balls on portions of the line, as well as the historical data indicating that no plane crashes have taken place on the shared right of way in the past 10 years.

En-route: The transmission lines are well below any criteria to be considered as an obstacle to an en-route IFR (Instrument Flight Rules) airway and are not located in any common corridor for visual operation.

Aerial Crop Dusting Application- The corridor is primarily located to the southeast of areas of vegetation. Since the area is surrounded mostly by desert terrain, crop dusting should not be a risk factor. Also, the lines are within FAA allowable minimum height limits.

Since the area surrounding the shared right of way is unpopulated desert terrain, there are no altitude restrictions for aircrafts, but based on the information listed above, there is enough significant data to conclude that aircrafts would not pose a hazard for the shared right of way.

R6: Risk of station related problems resulting in loss of two lines for a single event

The Imperial Valley 500kV bus is designed to operate as breaker-and-half, in ultimate configuration. Currently, the bus is being operated as a ring bus. When the new 500kV Sunrise Powerlink line is installed the bus will be reconfigured to operate as a combination breaker-and-half and double-breaker-double-bus. This configuration will increase the bus reliability in a stuck breaker contingency and can be seen in Appendix A5. For a single breaker failure to take out both 500 kV lines under either configuration, there would need to be a breaker out for maintenance followed by a breaker failure.

The existing Imperial Valley - Miguel line is protected by three primary-grade, piloted protection systems. The following equipment is used: 1) SEL-421 distance / over-current relays communicating over power line carrier, using three-phase Mode 1 coupling. The

power line carrier transmit/receive equipment is RFL-9780; 2) GE L-90 line differential/distance/over-current relays communicating over digital microwave; and 3) SEL-311L line differential/over-current relays communicating over digital microwave. In addition, transfer trip is provided using RFL-9780 (power line carrier) and RFL-9745 (microwave) teleprotection units.

At this point, SDG&E plans to install a similar protection system for the Imperial Valley - Central 500 kV line as discussed above, with the understanding that communication options are still under discussion. The three protective relays shown above would be applied, and two diverse communication paths will be incorporated, with power line carrier, digital microwave and fiber optic being the communication systems under discussion.

The Miguel substation terminates the 500 kV SWPL line with two 500/230 kV transformers. The Miguel 500 kV substation is configured as a ring bus. Therefore, a fault on either Miguel transformer would not cause an outage to the Imperial Valley - Miguel line.

The initial proposed configuration for the Central 500 kV substation would be similar to the Miguel 500 kV substation with a ring bus and two 500/230 kV transformers. Again a fault on either Central transformer would not cause an outage the Imperial Valley - Central line.

R7: Risk of natural disasters (ice, wind, snow or earth slides, flood, etc.) affecting both lines

The climate in Imperial Valley is typical of desert conditions, where it is mostly hot and dry (25 percent average relative humidity). Temperatures range from the low mid 30's in January to highs of 110 in July and August. The average low temperature is around 55 degrees and the average high temperature is 89.6 degrees. There are essentially two seasons for the Imperial Valley area, one being summer and the other winter. The transition periods between the two are very short.

The elevation of most of the Imperial Valley is near sea level or below. The Salton Sea is the lowest point at 235 feet below sea level. Due to the terrain, and the climate of Imperial Valley being representative of a desert, it is highly unlikely that there would be a risk of hazardous winter related events occurring. There is also very little moisture, with rainfalls bringing in an average of 2.92 inches of rainfall each year. The maximum precipitation occurs in January with an average of .51 inches. This amount of rain is not likely to cause flooding in the area.

There have been three tornadoes in the past forty one years in Imperial County with the most recent one occurring in 1992. This tornado was a category F0. The other two took place in the years 1965 and 1972. Both of these occurred before the SWPL was put in service. The one that occurred in 1965 was a category F1 and the one in 1972 was a category F0. According to the Fujita Tornado Damage Scale, an F0 tornado typically has

wind speeds less than 73 mph. An F1 tornado is between 73 to 112 mph and can cause mild to moderate damage. Both of these are weak scaled tornados. There was no SWPL outage associated with the F0 tornado in 1992.

Imperial County is the termination point of the San Andreas Fault. The San Andreas Fault runs from San Francisco southeast to the Imperial Valley, where it fragments into a number of small faults. There have not been any reported transmission line failures due to an earthquake in this area. The map shown in Figure 9 recorded all seismic events for 1932-1996. Each red pixel represents an earthquake⁷. The surface traces, shown as light blue-green lines, are the major faults in the area. The most prominent fault is the San Andreas Fault which runs from the lower right corner to the upper left hand corner.

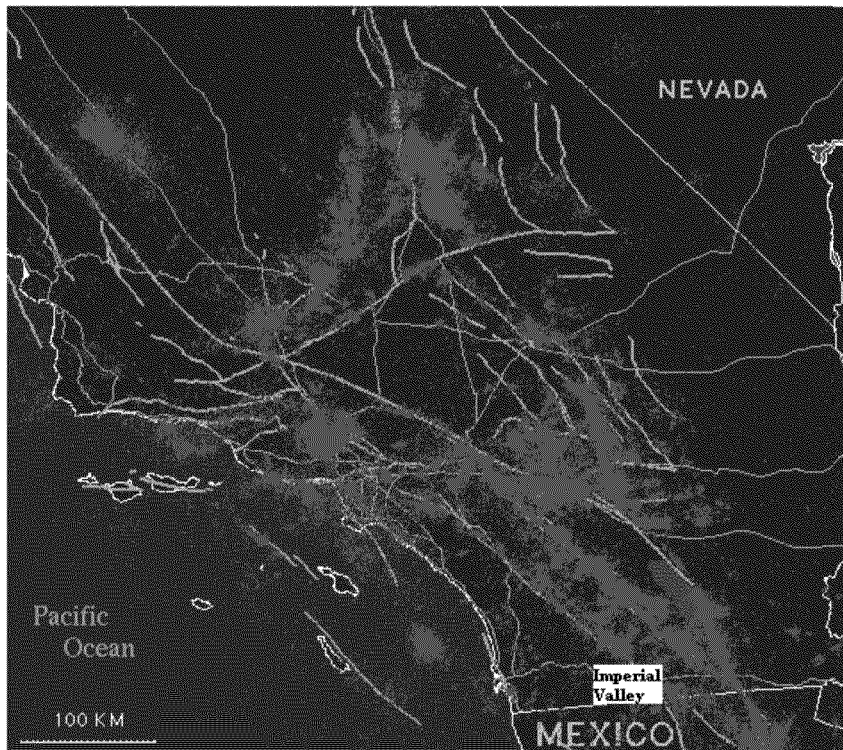

Figure 9: California Earthquakes for 1932-1996

R8: Risk of loss of two lines due to an overhead crossing

There are no existing or proposed overhead crossings within the shared right of way, making this event unlikely. Pictures of the existing line can be seen in Appendix A4.

⁷ California Seismicity for 1932-1996, *Southern California Earthquake Data Center*, Available at {"http://www.data.scec.org/general/socalcut.html"}. Accessed 5/1/2006 Page 25

R9: Risk of loss of two lines due to vandalism/malicious acts

There are no known outages that have occurred due to vandalism or malicious acts on the shared right of way. Shooting of insulators would be a typical vandalism related event, but has not taken place within the proposed shared right of way.

R10. Risk of flashover due to vegetation

The risk of flashover due to vegetation is low in the proposed path. This is mostly due to the desert terrain. The vegetation in the corridor consists primarily of cacti and bushes, neither of which grows above five to ten feet in height. Land patrols are performed once every three years and aerial patrols are performed twice a year. This frequency of patrols would aid in the prevention of flashovers that could occur due to vegetation. From the pictures of the towers shown in Appendix A4, vegetation is typically no more than five to ten feet high within the path of the common corridor. An example of typical vegetation that can be found in Imperial Valley can be seen below in Figure 10. The lack of vegetation within this corridor makes it an extremely unlikely event that both lines would trip due to a flashover caused by vegetation.

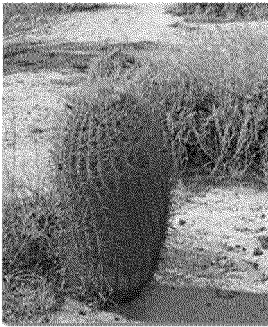

Figure 10: Arizona Barrel Cactus
Maximum Height of 4-11 feet



Figure 11: Typical vegetation on SWPL

From Figure 11, the height of the bush barely reaches past the base of the tower. Within the corridor, Figure 11 is a good approximation of the height of the present vegetation.

More pictures of the towers in the corridor and the surrounding vegetation can be found in Appendix A4.

R11: Risk of a single breaker failure causing loss of two lines

As stated before, the Imperial Valley 500 kV substation will initially be reconfigured to a breaker-and-a-half arrangement and a double bus-double breaker arrangement. This arrangement can be seen in Appendix A5. The Imperial Valley substation is designed for a breaker-and-a-half layout and the double bus-double breaker arrangement may ultimately be configured as a breaker-and-a-half. For a single breaker failure to take out both 500 kV lines under either configuration, there would need to be a breaker failure and a breaker out for maintenance.

While such an event is possible, it is a very low probability event (see calculations in Step 3 of this report where $P_B = 0.0000458$).

Step 5. Exposure Analysis

The exposure to the system is estimated to be, at worst case, 675 hours per year or 7.71% per year. However, the likelihood of this exposure in real time operations will be significantly reduced. This worst case exposure is based on planning scenarios which assume imports into the San Diego area are maximized while internal generation in the San Diego area is minimized. It is important to note, that these planning scenarios are extremely unlikely to be seen in real time operations as the San Diego Area has approximately 3000 MW of internal generation available and a projected summer peak load for 2010 of 5000 MW. It is reasonable to assume that SDG&E will have a significant amount of internal generation on-line when SDG&E's load is above 3600 MW. At 3600 MW of load and above, it is possible that imports into the San Diego area could be 3100 MW. With imports above 3100 MW, SDG&E may need to drop load for the double line outage (see discussion in Step 6). Though these planning scenarios are unlikely in normal real time operations, these conditions could be approached during extreme emergency conditions, but for the purposes of this report the expected exposure will be significantly less than the worst case estimate of 7.71%.

To calculate the exposure, SDG&E started with the 2006 actual load duration curve and scaled this curve upwards to match the 2010 peak load forecast, as can be seen in Figure 12. In 2010, when SDG&E load is above 3600 MW, the double line outage of Imperial Valley-Miguel and Imperial Valley-Central may expose the San Diego area to potential load drop conditions under planning scenarios. This was determined from operating procedures that indicate imports of 3100 MW are not achievable unless SDG&E's load is above 3600 MW. Therefore, planning scenarios where the San Diego area load is above 3600 MW and the San Diego area import is greater than 3100 MW, may expose the San Diego area to load drop in order to meet NERC/WECC criteria.

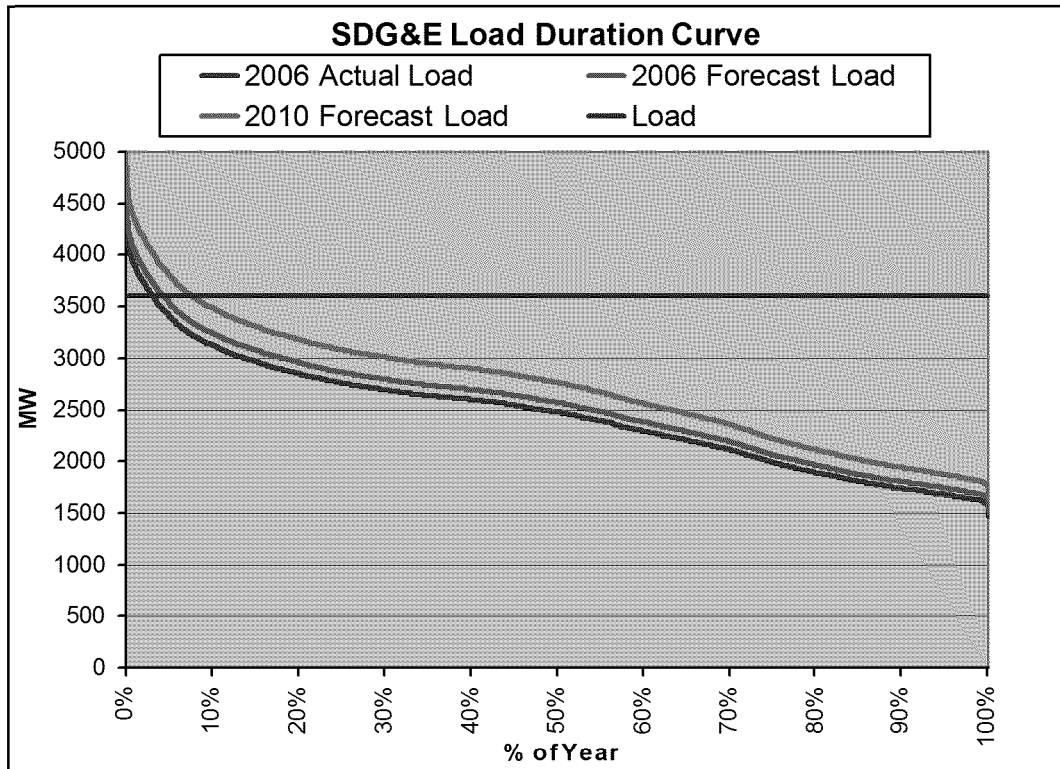

Figure 12: SDG&E Load Duration Curve

Step 6. Consequence of an Outage

This section describes the impact, from transient stability and post transient perspectives, that a double line outage of Imperial Valley - Miguel and Imperial Valley - Central 500 kV lines would have on the system at a time when the system is in an exposure condition as described in Step 5. The consequences to the grid of a double contingency of the Imperial Valley - Miguel and Imperial Valley - Central lines would be the need to shed enough SDG&E load to reduce the import to 3100 MW into San Diego. For 2010, the amount of load shed would be at worst case, approximately 1000 MW given the planning scenario described to evaluate the exposure analysis. Given different planning scenarios which equate to more realistic operating conditions the amount of load drop necessary to meet NERC/WECC criteria would likely be reduced. This amount of load drop necessary will also vary depending on system conditions in not only SDG&E, but also in Southern California Edison (SCE) and the Comision Federal de Electricidad (CFE).

The 2010 heavy summer power flow base case approved by participants of the CAISO South Regional Transmission Plan (CSRTP) was utilized for the transient stability and post transient analysis. The case has the "1 in 10" year load forecast for SDG&E of approximately 5000 MW and modeled over 4000 MW of SDG&E imports. The dynamic data associated with this case which was also approved by the CAISO CSRTP was also utilized.

Transient Stability

Transient stability is a commonly accepted analysis that illustrates a time domain system response under a given disturbance. This analysis shows whether the system has positive damping during a given disturbance and whether or not it meets the transient voltage dip criterion. The GE PSLF program was used to perform the transient stability analysis.

No violations of WECC's transient stability criteria were found and these results are documented in the summary output in Appendix E. The transient stability analysis also found robust damping shown by the plots in Appendix E.1.

Post Transient Analysis

Utilizing the same power flow case as the transient stability analysis, the post transient analysis shows the system is able meet WECC/NERC Category D post transient criteria with load drop. At worst case, the required load drop is approximately 400MW within the SDG&E load pocket.

The following summarizes the analysis performed to determine the amount of load shed required to meet Category C criteria for an N-2 outage of Imperial Valley – Miguel and Imperial Valley – Central lines.

Study parameters

The study looked at the following contingencies:

- N-2 of Sunrise and SWPL, no SPS
- N-2 of Sunrise and SWPL, tripping of Imperial Valley generation
- N-2 of Sunrise and SWPL, cross-trip of Otay Mesa-Tijuana 230 kV line⁸
- N-2 of Sunrise and SWPL, tripping of Imperial Valley generation followed by cross-trip of Otay Mesa-Tijuana 230 kV line

The VSAT voltage stability program was used to simulate load drop in the SDG&E service area in 100 MW increments, to determine at what point the system could operate without cascading outages. VSAT monitored thermal overloads in CFE, IID, SCE, and SDG&E on facilities over 100 kV. NERC Category C voltage criteria was also applied in the same areas for buses over 100 kV. A reactive margin test of 2.5% was also applied to the case.

Thermal Results

⁸ The CFE SPS that protects its 230 kV system can be set to trip either Imperial Valley-La Rosita 230 kV or the Tijuana-Otay Mesa 230 kV line. For the purposes of this study, it was assumed that CFE will be operating in summer mode, with the cross-trip SPS opening the Tijuana-Otay Mesa line.

The thermal results are summarized as follows:

- At 4100 MW of import without load shedding, simultaneous loss of both SWPL and Sunrise results in severe thermal overloads in CFE. Tripping the Imperial Valley generation is insufficient to relieve these overloads. Cross-tripping of the Tijuana-Otay Mesa 230 kV line causes the system to undergo voltage collapse.
- At 400 MW of load drop, the case solves after tripping of the IV generation and cross-tripping of the Tijuana-Otay Mesa 230 kV line, relieving overloads in CFE's system. Overloads now occur in SCE's 230kV system (Barre-Ellis, Chino-Mira Loma East).
- At 600 MW of load drop, following the generation trip and cross-trip the overloads on Barre-Ellis and Chino-Mira Loma East are 103% and 107.2%, respectively.
- At 900 MW of load drop, following the generation trip and cross-trip, the Barre-Ellis overload is relieved. The remaining overload on Chino-Mira Loma East is reduced to 101.3%.
- At 1000 MW of load drop, there are no further overloads.

For this analysis, the limiting elements for SDG&E import and subsequent load dropping for the N-2 contingency of Imperial Valley – Miguel and Imperial Valley – Central were found to be:

- Barre-Ellis 230 kV
- Chino-Mira Loma East 230 kV

The minimum load drop level appears to be 1000 MW. At this level of load drop, the system met the Category C criteria for post-transient voltage and reactive margin.

Subsequent sensitivities indicated that flow on these elements is strongly affected by SCE import and dispatch; thus the load drop within SDG&E necessary to prevent post-contingent overloads on these elements will vary depending on system conditions. It is also important to note that the limiting elements for this N-2 contingency are external to SDG&E on CFE's and SCE's 230 kV systems.

This study supports the current SDG&E all lines in service import limit of 3100 MW. The simultaneous loss of both Imperial Valley – Miguel and Imperial Valley – Central is more or less equivalent to the loss of Imperial Valley – Miguel only for the current system configuration. Dropping 1000 MW of load from an import level of 4100 MW gets the total system imports down to 3100 MW.

Appendix H provides line flows for the N-2 contingencies with the generation trip at Imperial Valley and cross trip of the Otay Mesa-Tijuana 230 kV line at 0 and 400 MW of load drop.

Post-Transient Voltage Results

The post-transient voltage results can be summarized as follows:

- At 4100 MW of import without load shedding, the simultaneous loss of both Imperial Valley – Miguel and Imperial Valley – Central lines creates voltage violations in CFE. In addition to the loss of both lines, the tripping of the IV generation and cross-trip of the Otay Mesa-Tijuana 230 kV line, results in voltage collapse, however with the addition of approximately 1300 MVAR of reactive support in the Southern California area the voltage collapse was eliminated.
- At 400 MW of load drop, following tripping of the IV generation and cross-tripping of the Otay Mesa-Tijuana 230 kV line, there are no Category C post-transient voltage violations.

These results support the conclusion that the limiting factors for the N-2 loss of Imperial Valley – Miguel and Imperial Valley – Central followed by load shedding are primarily thermal in nature.

Reactive Margin Results

The reactive margin results are summarized in the following table:

Load Shed Level	Contingency & SPS	System Results
0 MW	N-2	Margin violation
	N-2 gentrip	No margin violation
	N-2 gentrip w/cross-trip	Voltage Collapse ⁹
400 MW	N-2	No margin violation
	N-2 gentrip	No margin violation
	N-2 gentrip w/cross-trip	Margin violation
600 MW	N-2 gentrip	No margin violation
	N-2 gentrip	No margin violation
	N-2 gentrip w/cross-trip	No margin violation

Step 7. Report

The seven step process requires a report covering each of the steps in the performance category upgrade request. This report serves to fulfill that step of the process.

⁹ With the addition of approximately 1300 MVAR of reactive support in the Southern California area the voltage collapse was eliminated.

Comprehensive RPEWG Evaluation
SDG&E's Imperial Valley - Miguel 500 kV and Imperial Valley - Central 500 kV
Double Line Outage Probability Analysis

Executive Summary:

SDG&E requests that the double line outage of Imperial Valley - Miguel 500 kV and Imperial Valley - Central 500 kV project be granted Category D status by the RPEWG. This report contains robust line design information, as well as the probability analysis that will help justify the change to Category D performance requirement as well as the low risk of a double-line contingency outage. The compilation of this report was performed by following the “Seven Step Process for PBRC Adjustment”.

The common right of way for the Imperial Valley - Miguel 500 kV line and Imperial Valley - Central 500 kV line spans a length of approximately four miles. The MTBF was calculated to be between the range of 21 and 928 years. The reason the data was presented in a range of values is due to the shortage of significant data, which is needed to determine a set MTBF. The lower end of the range, 21 years, would not qualify for Category D status, but SDG&E feels that after review of the Robust Line Design criteria for SWPL, the MTBF would tend towards the higher end of the range of 928 years.

The eleven risk factors, shown in Table 5, were outlined in the Robust Line Design Features, which can also be found in Appendix C. Through a close analysis of these factors, SDG&E has justified that a significant risk does not exist for the double line outage of the Imperial Valley - Miguel 500 kV line and the Imperial Valley - Central 500 kV line.

	Risk	Risk Factor
R1	Fire affecting both lines	Low Risk
R2	One tower falling into another line	Low Risk
R3	Conductor from one line being dragged into another line	Low Risk
R4	Lightening strikes tripping both lines	Low Risk
R5	Aircraft flying into both lines	Low Risk
R6	Station related problems resulting in loss of two lines for a single event	Low Risk
R7	Natural disasters	Low Risk
R8	Loss of two lines due to an overhead crossing	Low Risk
R9	Loss of two lines due to vandalism/malicious acts	Low Risk
R10	Flashover to vegetation	Low Risk
R11	Single breaker failure causing loss of two lines	Low Risk

Table 5: Risk Factor Summary

Conclusion:

Based on the preceding information, the analysis performed is sufficient enough to move the performance criteria for the double line outage of Imperial Valley – Miguel and Imperial Valley – Central from Category C to Category D.

References:

1. American Meteorological Society, Available at <http://ams.allenpress.com/archive/1520-0450/38/7/figure/i1520-0450-38-7-1013-f01.jpg>. Accessed 4/26/2006. Page 22
2. “Performance Category Upgrade Request For Palo Verde Hub to North Gila Lines”, April 2006, Arizona Public Service Company. Pages 9-16
3. CIGRE Study Committee 13 Report as referenced in “Kangley – Echo Lake Double-Line Outage Probability Analysis” report, May 28, 2002, Bonneville Power Administration.
4. California Seismicity for 1932-1996, *Southern California Earthquake Data Center*, Available at <http://www.data.scec.org/general/socalcut.html>. Accessed 5/1/2006 Page 25
5. CPUC General Order 95 and Public Resource Code Section 4293 and 4292, *California Law*, Available at <http://www.leginfo.ca.gov/calaw.html>. Accessed 6/2/2006. Page 8
6. Imperial Valley Fires, *Imperial County*, Available at <http://www.fire.ca.gov/ab6/nhdl3.pd>. Accessed 4/18/2006. Page 30
7. “Performance Category Upgrade Request For Palo Verde Hub to North Gila Lines”, April 2006, Arizona Public Service Company. Pages 9-19
8. Engineering Statistics Handbook, *Constant repair rate (HPP/exponential) model*, Accessed 8/1/2006. Pages 1-6

Figure Number:	Page:	Description:
Figure 1	5	Proposed and Alternative Paths Map
Figure 2	6	Potential Shared Right of Way Diagram
Figure 3	8	Imperial Valley Substation
Figure 4	24	SWPL Fires
Figure 5	25	Closest Corridor Fire
Figure 6	26	Flash Density (1989-1996)
Figure 7	26	IV Flash Density (1989-1996)
Figure 8	27	APS Flash Density (1995-2004)
Figure 9	30	Arizona Barrel Cactus
Figure 10	31	Typical Vegetation on SWPL
Figure 11	31	California Earthquakes for 1932-1996
Figure 12	33	SDG&E Load Duration Curve
Figure 13	56	Alternative Path Segments
Figure 14	57	2007 San Diego Fire
Figure 15	58	Flash Density (1989-1996)
Figure 16	58	IV Flash Density (1989-1996)
Figure 17	59	APS Flash Density (1995-2004)
Figure 18	62	California Earthquakes for 1932-1996
Figure 19	63	Chaparral Example

Table Number:	Page:	Description:
Table 1	17	MTBF Uncorrected
Table 2	18	Uncorrected Confidence Interval

Table 3	23	SWPL/SRPL MTBF Results
Table 4	23	Corrected Confidence Interval
Table 5	37	Risk Factor Summary
Table 6	64	Alternative Path Risk Factor Summary

Appendix Number:	Description:
A1	Imperial Valley Fires
A2	Tower Spacing Option A
A3	Tower Information
A4	Tower Pictures
A5	Breaker-and-a-Half Arrangement of IV substation
B	CPUC General Order 95 and Public Resource Code Section 4293 and 4292
C	Seven Step Process for Performance Category Upgrade Request
D	Tables of MTBF Confidence Interval Factors
E	Transient Voltage Dip Report
E1	Transient Stability Plots
F	Alternative Path Analysis
G	Alternative Path Tower Pictures
H	Powerflows

Appendices

Appendix A1 – Imperial Valley Fires

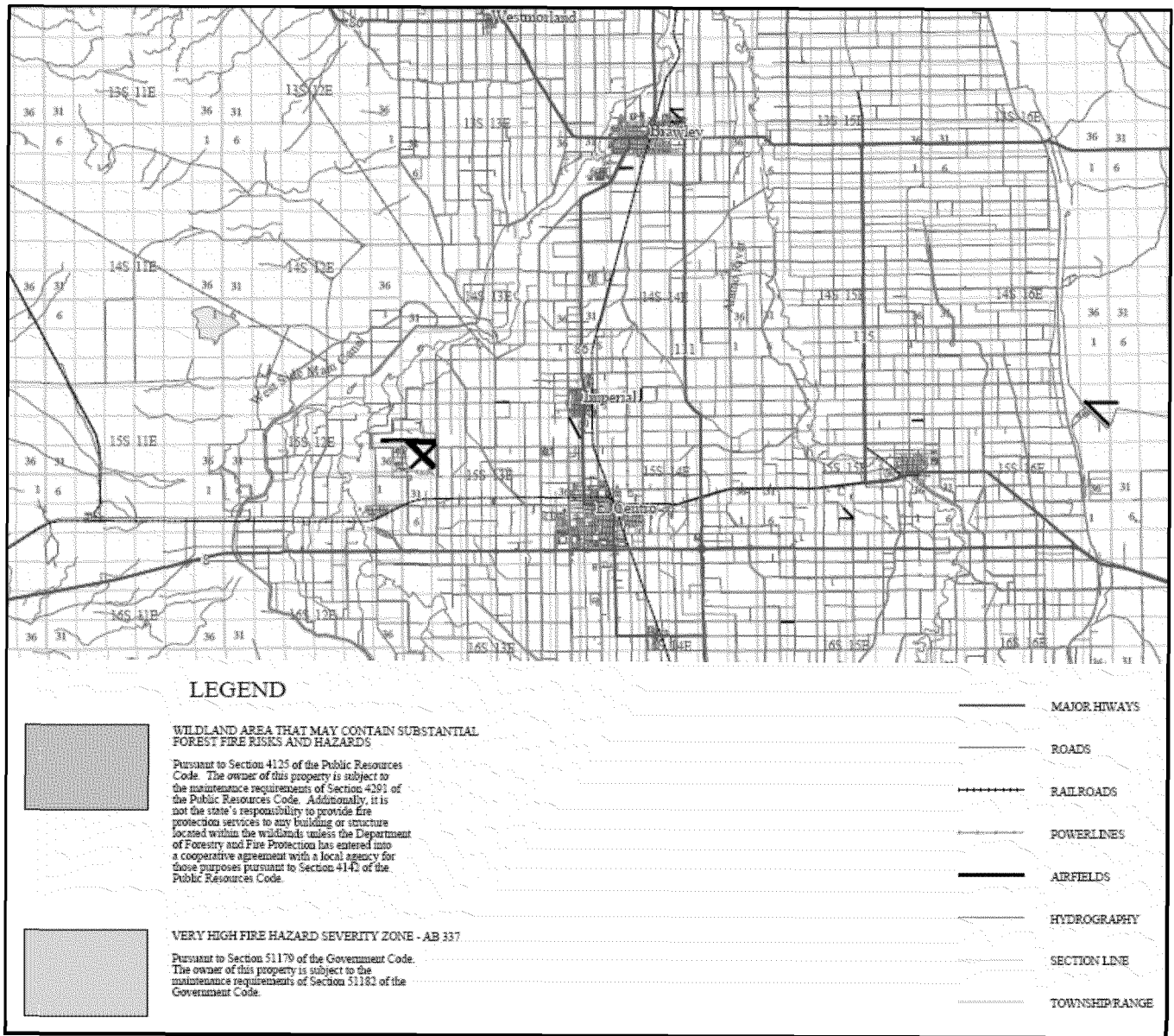

This diagram shows that the area surrounding Imperial Valley does not contain fire hazards.¹⁰

Appendix A2 – Tower Spacing

¹⁰ Imperial Valley Fires, *Imperial County*. Accessed 4/18/2006. Page 30

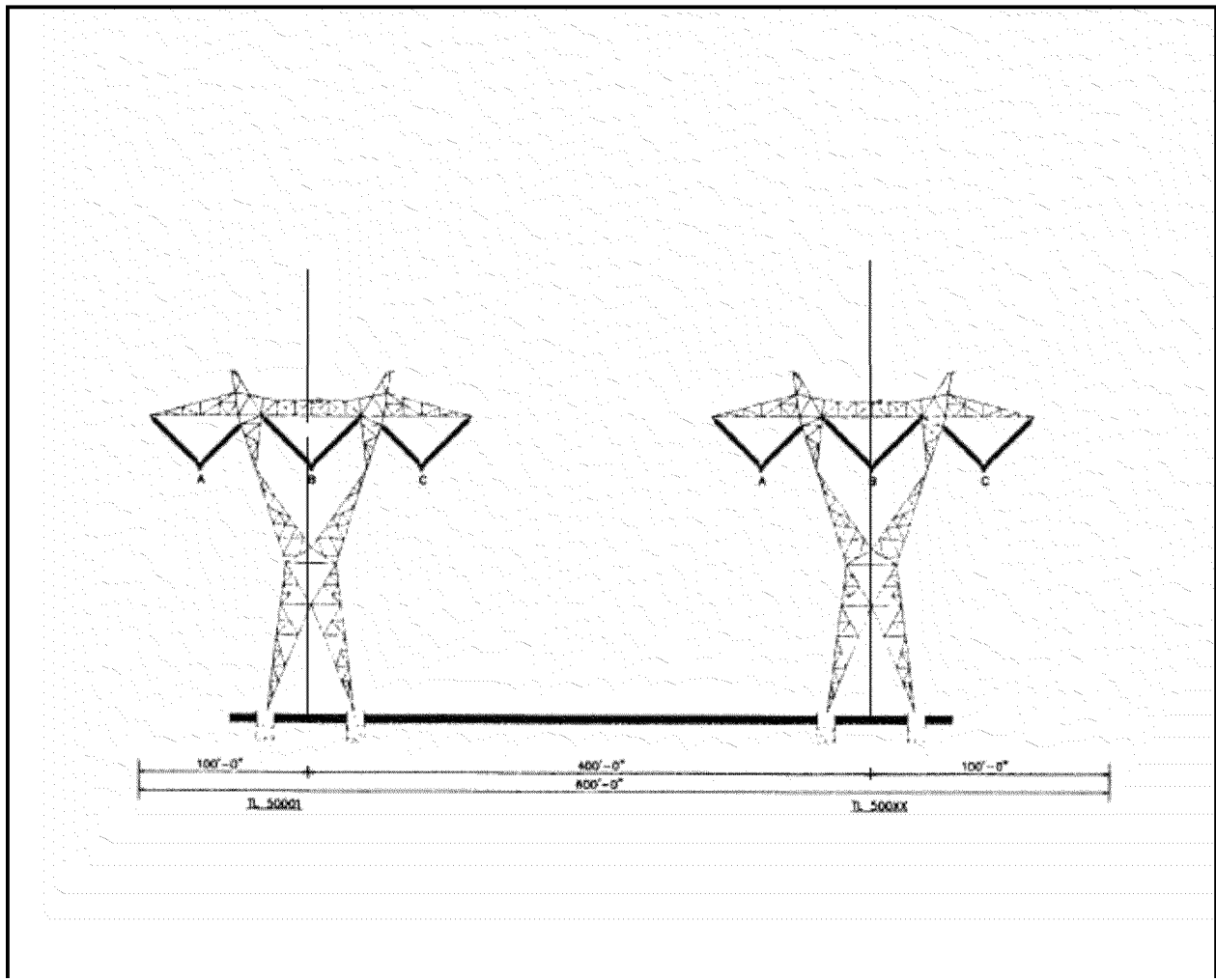

The tower on the left represents TL 50001 and the tower on the right is TL 50002.

Appendix A3

Tower Structures										
seq no.	sdge no	type	height	angle	drawing no	span ahead	post mile	Distance between	Distance from IV	
IV							84.44383	0.34594697	0.345947	
A	50281	313	ELD	95	27*21'13"	123.8'	411	84.09788	0.07784	0.423787
	50280	312	ETT	146		175.5	1642.6	84.02004	0.3111	0.734887
	50279	311	ETT	143		172.5	1755	83.70894	0.33239	1.067277
	50278	310	ELT	116			1765	83.37655	0.33428	1.401557
	50277	309	ELT	116		145.5	1755	83.04227	0.33238	1.733937
	50276	308	ELT	116			1790	82.70989	0.33902	2.072957
	50275	307	ELT	119		148.5	1774	82.37087	0.33598	2.408937
	50274	306	ELT	116			1771	82.03489	0.33542	2.744357
	50273	305	ELT	116		145.5	1780	81.69947	0.33712	3.081477
	50272	304	ELT	119		148.5	1775	81.36235	0.33618	3.417657
	50271	303	ELT	116		145.5	1795	81.02617	0.33996	3.757617
	50270	302	ELT	119			1800	80.68621	0.34091	4.098527

Appendix A4

Case A

Tower 50281 – Dead-End Configuration



Tower 50280

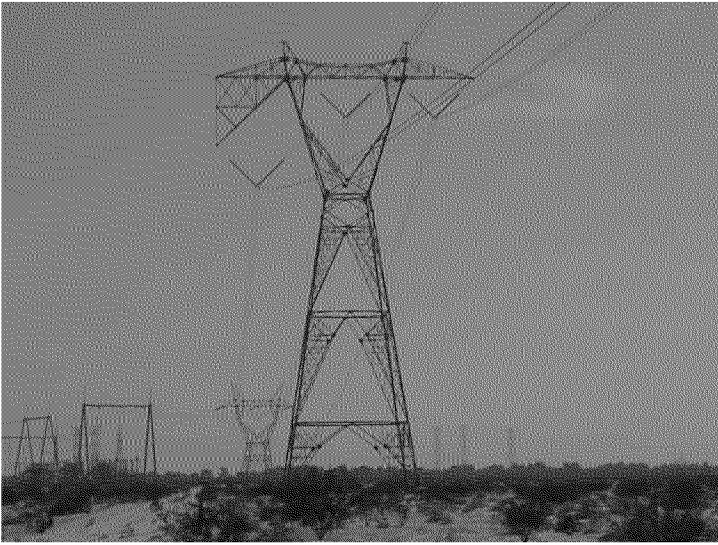

Tower 50279



Tower 50278

Tower 50277

Tower 50276

Tower 50275

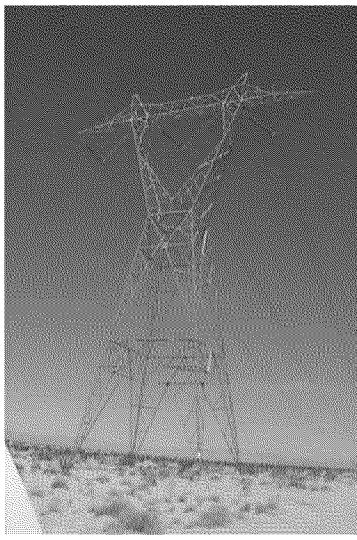

Tower 50274

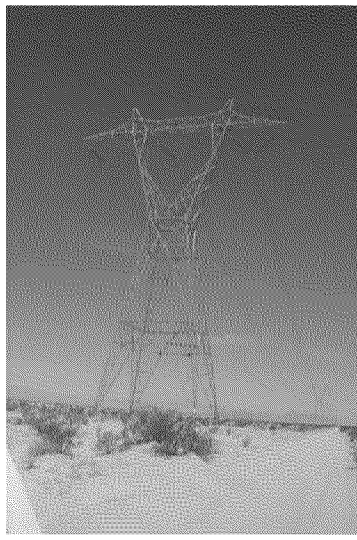

Tower 50273

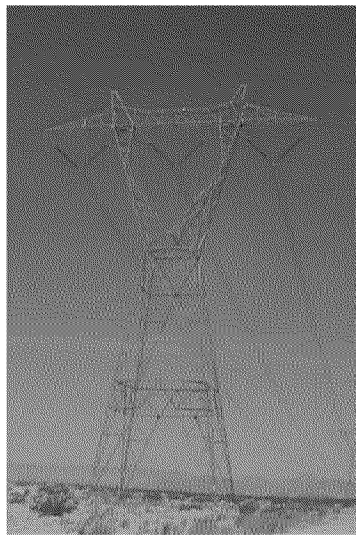

Tower 50272

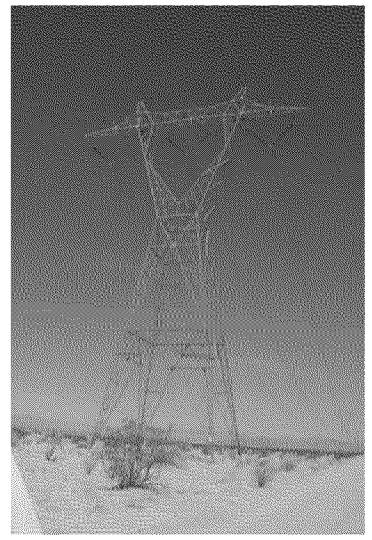

Tower 50271

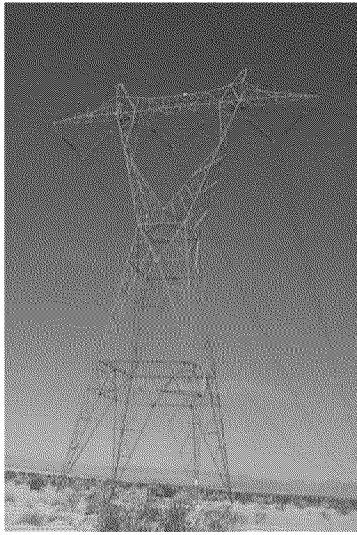

Tower 50270

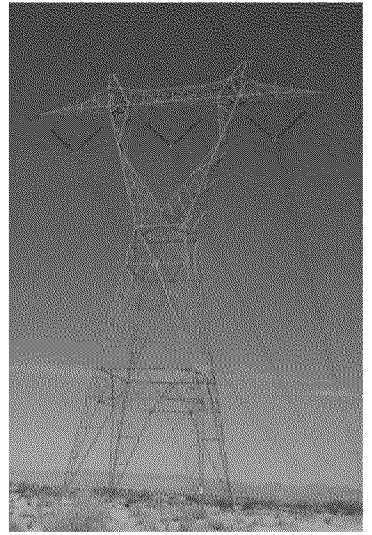
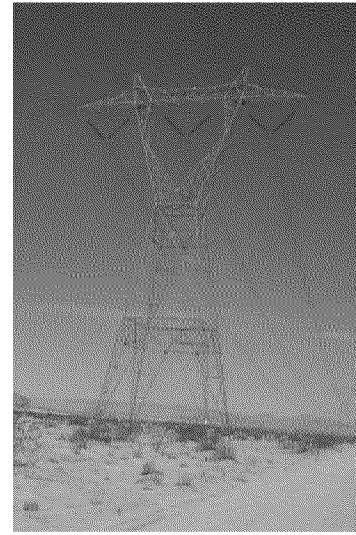
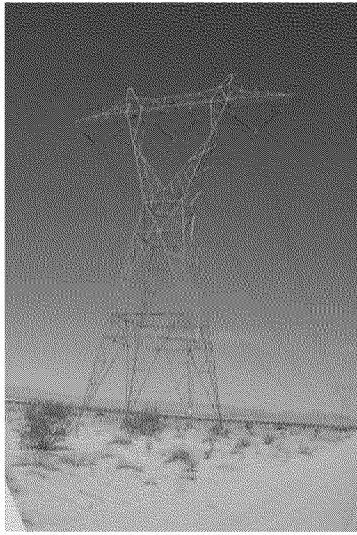

Appendix A5 – Proposed Substation Arrangement

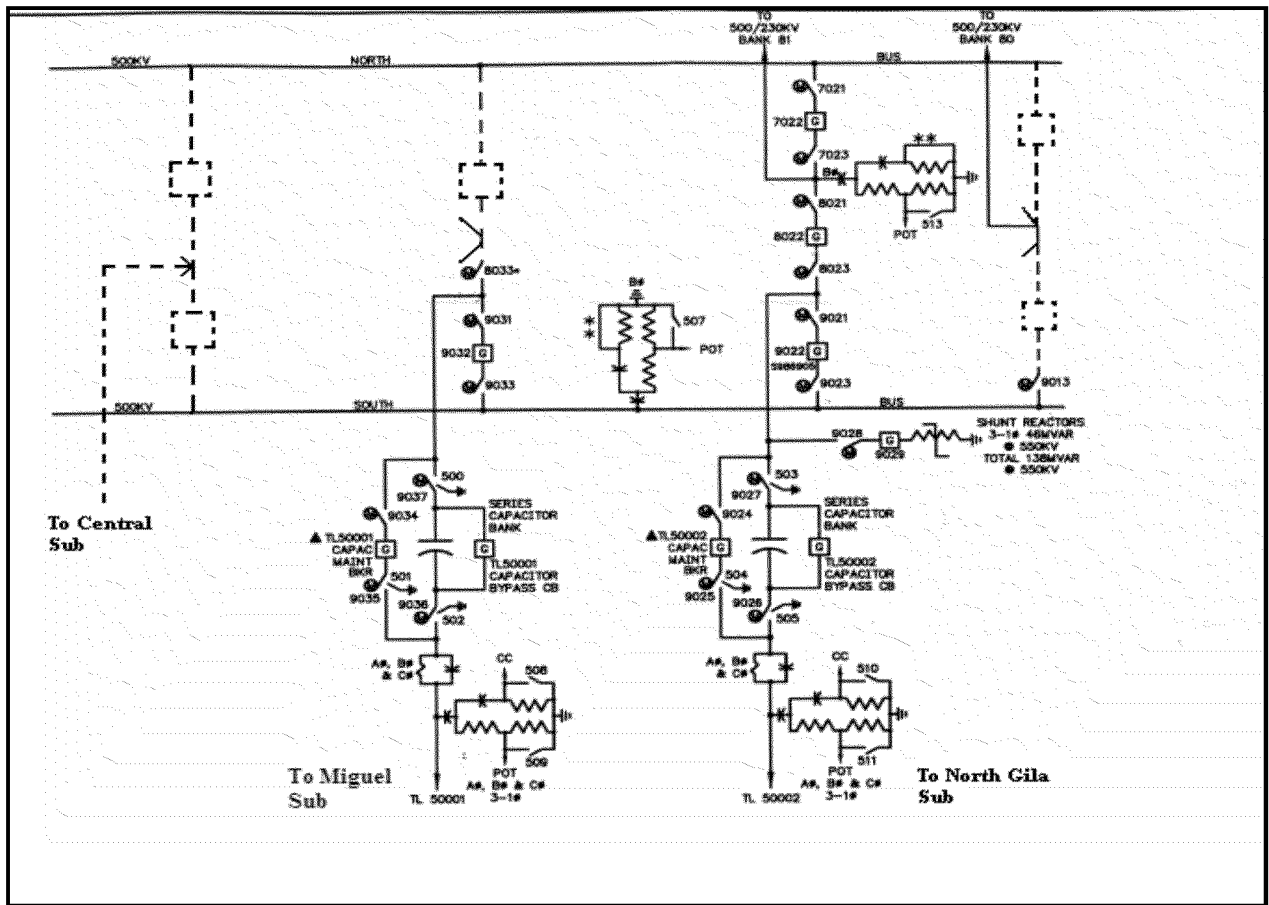

****The dashed portions of the lines represent changes from the ring bus schematic to a combination breaker and a half and double breaker-double bus configuration.**

Appendix B

CPUC General Order 95 and Public Resource Code Section 4293 and 4292¹¹

4292. Except as otherwise provided in Section 4296, any person that owns, controls, operates, or maintains any electrical transmission or distribution line upon any mountainous land, or forest-covered land, brush-covered land, or grass-covered land shall, during such times and in such areas as are determined to be necessary by the director or the agency which has primary responsibility for fire protection of such areas, maintain around and adjacent to any pole or tower which supports a switch, fuse, transformer, lightning arrester, line junction, or dead end or corner pole, a firebreak which consists of a clearing of not less than 10 feet in each direction from the outer circumference of such pole or tower. This section does not, however, apply to any line which is used exclusively as telephone, telegraph, telephone or telegraph messenger call, fire or alarm line, or other line which is classed as a communication circuit by the Public Utilities Commission. The director or the agency which has primary fire protection responsibility for the protection of such areas may permit exceptions from the requirements of this section which are based upon the specific circumstances involved.

4293. Except as otherwise provided in Sections 4294 to 4296, inclusive, any person that owns, controls, operates, or maintains any electrical transmission or distribution line upon any mountainous land, or in forest-covered land, brush-covered land, or grass-covered land shall, during such times and in such areas as are determined to be necessary by the director or the agency which has primary responsibility for the fire protection of such areas, maintain a clearance of the respective distances which are specified in this section in all directions between all vegetation and all conductors which are carrying electric current:

(a) For any line which is operating at 2,400 or more volts, but less than 72,000 volts, four feet.

(b) For any line which is operating at 72,000 or more volts, but less than 110,000 volts, six feet.

(c) For any line which is operating at 110,000 or more volts, 10 feet.

In every case, such distance shall be sufficiently great to furnish the required clearance at any position of the wire, or conductor when the adjacent air temperature is 120 degrees Fahrenheit, or less. Dead trees, old decadent or rotten trees, trees weakened by decay or disease and trees or portions thereof that are leaning toward the line which may contact the line from the side or may fall on the line shall be felled, cut, or trimmed so as to remove such hazard. The director or the agency which has primary responsibility for the fire protection of such areas may permit exceptions from the requirements of this section which are based upon the specific circumstances involved.

¹¹ CPUC General Order 95 and Public Resource Code Section 4293 and 4292, *California Law*. Accessed 6/2/2006. Page 33

Appendix C: Seven Step Process for Performance Category Upgrade Request

- Step 1: Project (Facility) Description
- Step 2: Outage Database - The Sample
- Step 3: Mean Time Between Failure Calculation
- Step 4: Robust Line Design
- Step 5: Exposure Analysis
- Step 6: Illustrate the Consequence of an Outage
- Step 7: Report

Robust Line Design - Risk Factors

The following list of risk factors is to be discussed by the applicant. It is expected that the applicant will describe how the line's design variables, including maintenance and/or procedures that are in place, can mitigate these risk factors and contribute to a very low probability of a multiple line outage.

- R1: Risk of fire affecting both lines
- R2: Risk of one tower falling into another line
- R3: Risk of a conductor from one line being dragged into another line
- R4: Risk of lightning strikes tripping both lines
- R5: Risk of an aircraft flying into both lines
- R6: Risk of station related problems resulting in loss of two lines for a single event
- R7: Risk of natural disasters (ice, wind, snow or earth slides, flood, etc.) affecting both lines
- R8: Risk of loss of two lines due to an overhead crossing
- R9: Risk of loss of two lines due to vandalism/malicious acts
- R10: Risk of flashover to vegetation.
- R11: Risk of a single breaker failure causing loss of two lines

Design Variables

The following are examples of design variables that can be used to mitigate the above risk factors.

- D1: Substation breaker configuration (R6,R11)
- D2: Circuit centerline spacing (R1,R2,R3,R8)
- D3: Span length (R3)
- D4: Tower design (R2,R7,R8)
- D5: Use of shield wires for lightning (R4)
- D6: Conductor support systems (R8)
- D7: Use of dead-end versus suspension towers (R3)
- D8: Use of single pole reclosing (R4)
- D9: Vegetation management (R1)
- D10: Fire watch curtailments (R1)
- D11: Shortening of line on common right-of-way (R1-R8)
- D12: Tower grounding (R4)
- D13: Protective relaying design and testing to minimize risk of sympathetic tripping (R6)
- D14: No splices in the conductor in overhead crossings (R8)
- D15: Maintenance program designed to reduce risk (R6, R9)
- D16: Established vegetative management program (R10)
- D17: Flood plain design, foundation built to sustain flood (R7)
- D18: Line/Tower location study for potential natural disasters (R7)

**Appendix D: Tables of MTBF
Confidence Interval Factors**

*Confidence bound factor tables
for 60, 80, 90 and 95%
confidence*

**Confidence Interval Factors to
Multiply MTBF Estimate⁹**

Num Fails r	60%		80%	
	Lower for MTBF	Upper for MTBF	Lower for MTBF	Upper for MTBF
0	0.6213	-	0.4343	-
1	0.3340	4.4814	0.2571	9.4912
2	0.4674	2.4260	0.3758	3.7607
3	0.5440	1.9543	0.4490	2.7222
4	0.5952	1.7416	0.5004	2.2926
5	0.6324	1.6184	0.5391	2.0554
6	0.6611	1.5370	0.5697	1.9036
7	0.6841	1.4788	0.5947	1.7974
8	0.7030	1.4347	0.6156	1.7182
9	0.7189	1.4000	0.6335	1.6567
10	0.7326	1.3719	0.6491	1.6074
11	0.7444	1.3485	0.6627	1.5668
12	0.7548	1.3288	0.6749	1.5327
13	0.7641	1.3118	0.6857	1.5036
14	0.7724	1.2970	0.6955	1.4784
15	0.7799	1.2840	0.7045	1.4564
20	0.8088	1.2367	0.7395	1.3769
25	0.8288	1.2063	0.7643	1.3267
30	0.8436	1.1848	0.7830	1.2915
35	0.8552	1.1687	0.7978	1.2652
40	0.8645	1.1560	0.8099	1.2446
45	0.8722	1.1456	0.8200	1.2280
50	0.8788	1.1371	0.8286	1.2142
75	0.9012	1.1090	0.8585	1.1694
100	0.9145	1.0929	0.8766	1.1439
500	0.9614	1.0401	0.9436	1.0603

**Confidence Interval Factors to
Multiply MTBF Estimate¹²**

Num Fails	90%		95%	
	Lower for MTBF	Upper for MTBF	Lower for MTBF	Upper for MTBF
0	0.3338	-	0.2711	-
1	0.2108	19.4958	0.1795	39.4978
2	0.3177	5.6281	0.2768	8.2573
3	0.3869	3.6689	0.3422	4.8491
4	0.4370	2.9276	0.3906	3.6702
5	0.4756	2.5379	0.4285	3.0798
6	0.5067	2.2962	0.4594	2.7249
7	0.5324	2.1307	0.4853	2.4872
8	0.5542	2.0096	0.5075	2.3163
9	0.5731	1.9168	0.5268	2.1869
10	0.5895	1.8432	0.5438	2.0853
11	0.6041	1.7831	0.5589	2.0032
12	0.6172	1.7330	0.5725	1.9353
13	0.6290	1.6906	0.5848	1.8781
14	0.6397	1.6541	0.5960	1.8291
15	0.6494	1.6223	0.6063	1.7867
20	0.6882	1.5089	0.6475	1.6371
25	0.7160	1.4383	0.6774	1.5452
30	0.7373	1.3893	0.7005	1.4822
35	0.7542	1.3529	0.7190	1.4357
40	0.7682	1.3247	0.7344	1.3997
45	0.7800	1.3020	0.7473	1.3710
50	0.7901	1.2832	0.7585	1.3473
75	0.8252	1.2226	0.7978	1.2714
100	0.8469	1.1885	0.8222	1.2290
500	0.9287	1.0781	0.9161	1.0938

Appendix E: Transient Voltage Dip Report

Worst Condition Analysis Report				Case iv2_4200
Voltage at Load Buses				
Name	Initial Voltage	Percent Dip	Time	Duration

iv2.chf	No dips violating criteria.			
Worst dip was	8.87	at 20029 RII-69	69.0	
Worst Condition Analysis Report				Case iv2_4200
Frequency at All Buses				
Name	Initial Frequency	Percent Dip	Time	Duration

iv2.chf	No dips violating criteria.			
Worst dip was	0.23	at 14963 YUCCACT3	13.8	

Appendix E1: Transient Stability Plots

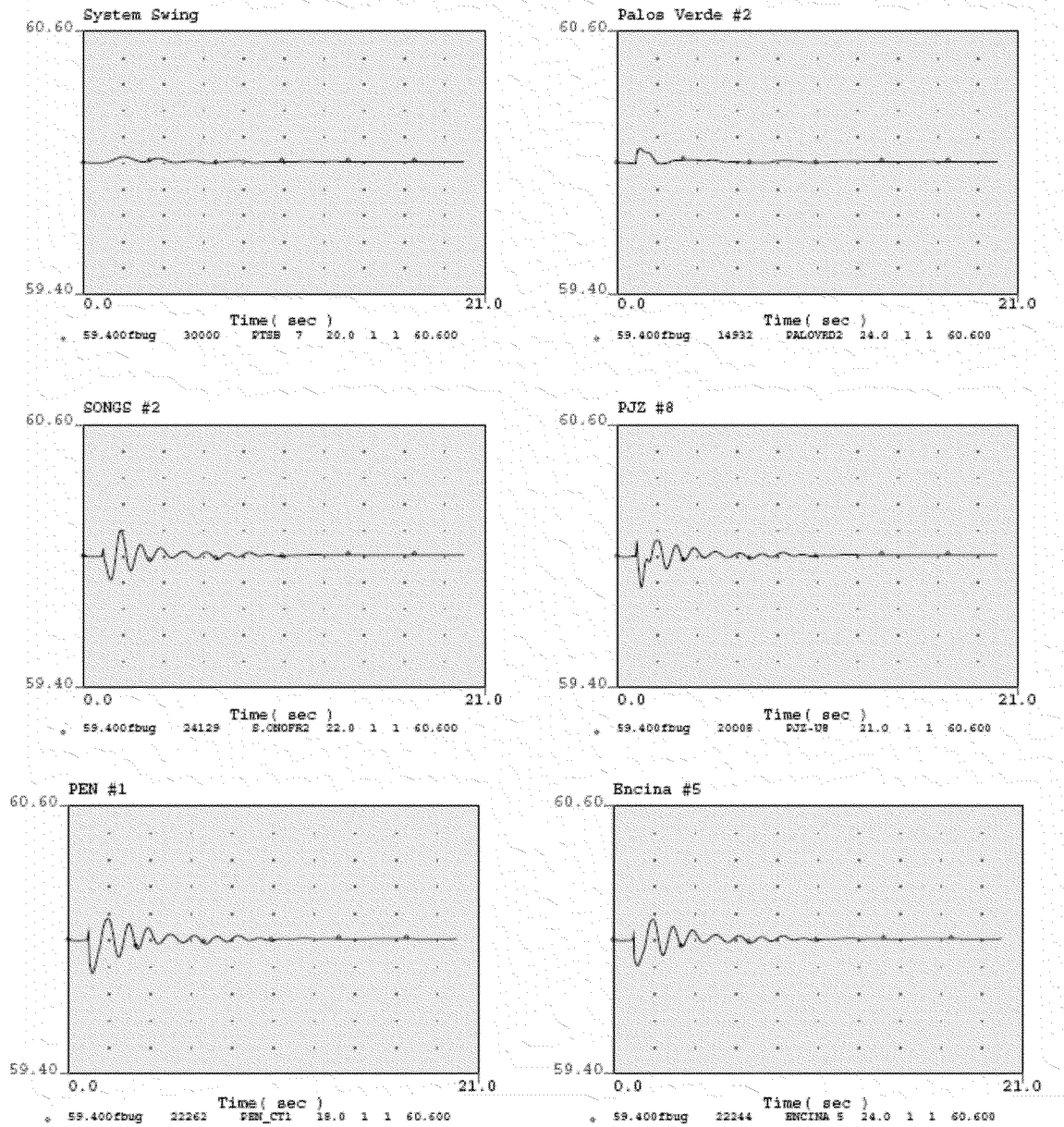

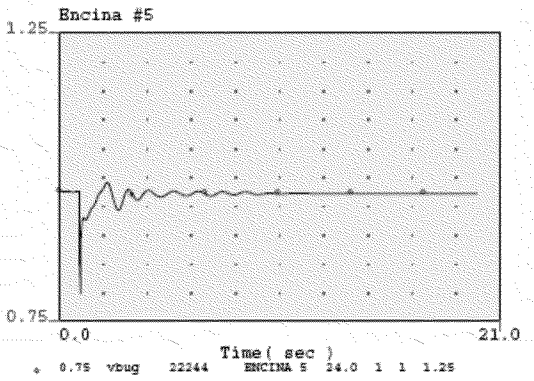
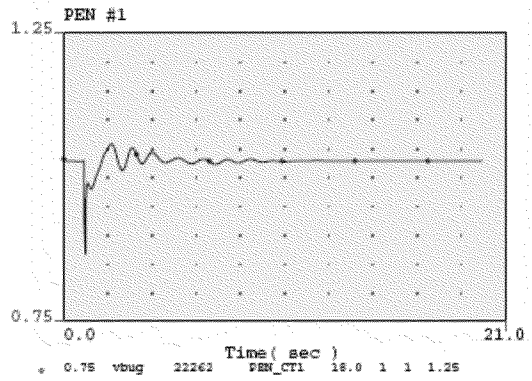
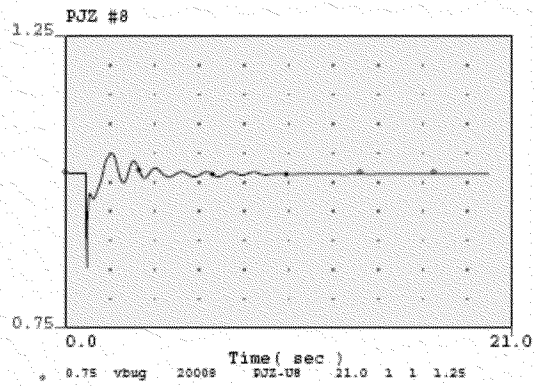
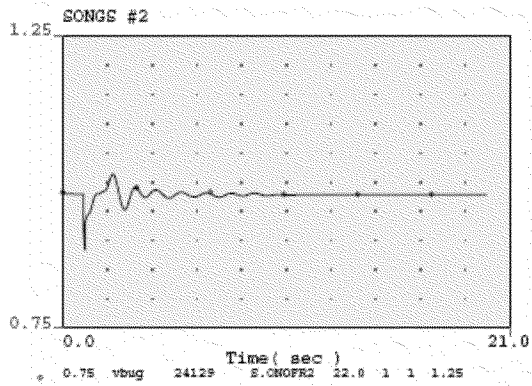
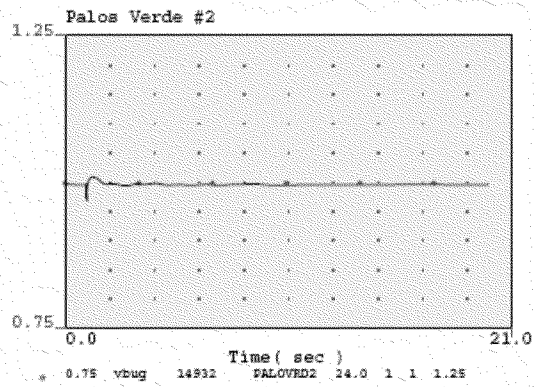
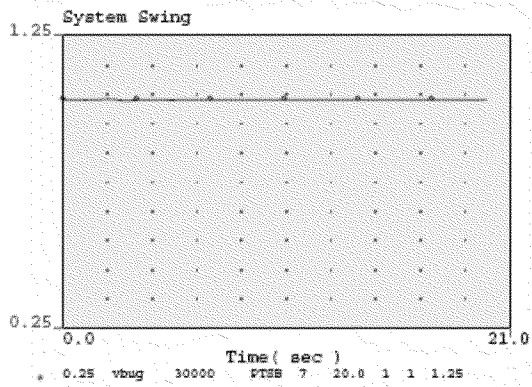

Appendix F

Alternative Path Analysis

This analysis is a modified version of the proposed path analysis for the seven step process analyzing the performance requirements for the double-contingency outage of the existing, Imperial Valley - Miguel 500 kV line, and the proposed Imperial Valley - Central 500 kV line. The Imperial Valley - Miguel 500 kV line segment is part of the existing “Southwest Powerlink” (SWPL) which runs from Palo Verde to Hassayampa to North Gila to Imperial Valley to Miguel. The Imperial Valley - Central 500 kV line is part of the proposed “Sunrise Powerlink” (SRPL) which will connect Imperial Valley to SDG&E’s Sycamore substation via the proposed 500 kV Central substation.

This analysis is to evaluate the performance category for an alternative path that is being considered for the Sunrise Powerlink project. For this alternative route, the 500kV Imperial Valley - Central line originates at the Imperial Valley substation and parallels the Imperial Valley - Miguel 500kV line for approximately 36 miles in the same right of way, before heading north to Central substation. (See Figure 13)

The Robust Line Design factors are the differentiating variables, within the seven step process, from this portion of the report to the previous portion analyzing the proposed path. The calculated MTBF range of 21 to 928 still holds true for the alternative path.

After reviewing the robust line design, SDG&E requests that the RPEWG evaluate and decide if the alternative path would also qualify for the performance category upgrade to Category D.

Alternative Path Analysis:

R1: Risk of fire affecting both lines

There have been weather-related incidents on the shared right of way for the alternative path. The line parallels a portion of the Imperial Valley – Miguel line for 36 miles with a minimal line separation of 400 feet. After these 36 miles, it continues to parallel the Imperial Valley - Miguel line for another 23 miles with varying degrees of separation. The separation ranges from 4 miles to 9 miles from the Imperial Valley – Miguel line. In order to better classify the different portions of the line paralleling the Imperial Valley – Miguel line, the alternative path will be divided into the following three segments.

Segment 1: Desert Terrain (Towers 50281-50162)

Distance of approximately 36 miles; 400 foot separation from Imperial Valley – Central line; no fires. The shared right of way is desert terrain, where there is a minimal chance of fires.

Segment 2: Partial Desert/Partial Chaparral Terrain (Towers 50162-50104)
Distance of approximately 11 miles; gradually increasing 8 mile separation from Imperial Valley – Central line; 2 fires. There are two fires which occurred in Oct 1999 and are located 9 miles from the point where the Imperial Valley – Miguel line no longer parallels the line.

Segment 3: Chaparral Terrain (Towers 50104-50059)
Approximately 12 miles in distance: approximately 4 mile separation from Imperial Valley – Central line; 9 fires; The reason behind the increased number of fire related incidents is this portion of the line is due to the highly vegetated area.

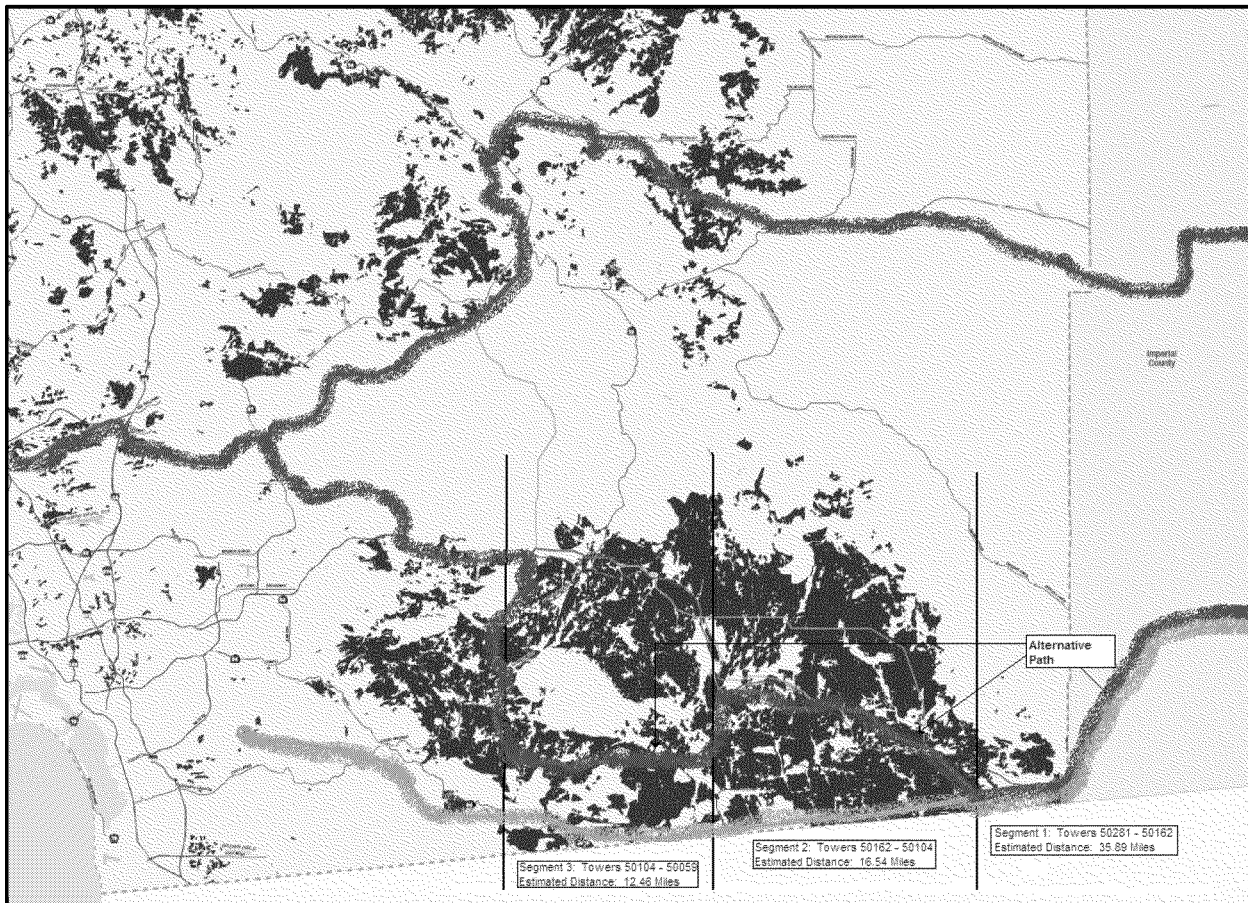

Figure 13: Alternative path segments

As shown in Figure 14 demonstrates that one fire incident may be capable of taking out both lines. The areas shown in red are the burn area. This fire occurred between October 21 and October 24, 2007. During this period of time, TL 50001 was initially de-energized for 74 hours due to safety. If the alternative path is chosen, history shows that a single fire could potentially take out both lines.

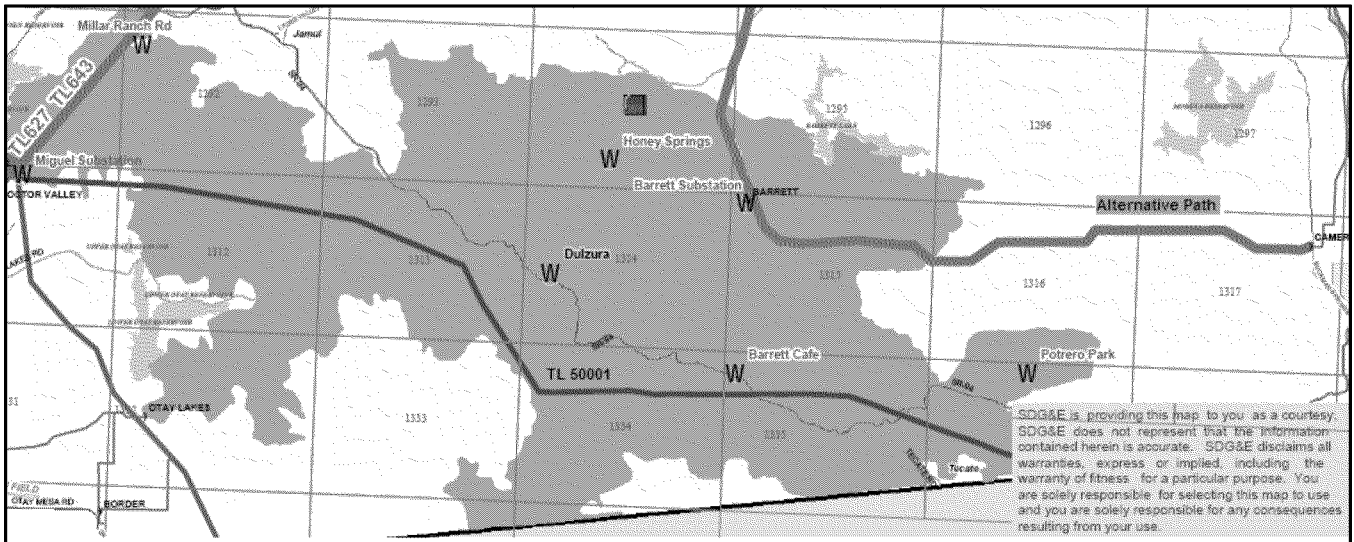

Figure 14: 2007 San Diego Fires

R2: Risk of one tower falling into another line

As stated earlier, there are varying degrees of separation among the Alternative path. Segment 1, which parallels a portion of the Imperial Valley – Miguel line for 36 miles. The other two segments are separated by a significant distance which would make the risk of one tower falling into another difficult.

The risk of one tower falling into another line is not anticipated to be a factor due to the spacing of the lines. The centerline spacing between towers would be greater than 400 feet, which makes it impossible for one tower to fall into another, since the height of the tower is smaller than the distance between the lines. The heights of the towers range from 50 feet to 158 feet.

Within this shared right of way there is a possibility that a generation interconnection transmission line will also be installed. Below is a potential example of this configuration:

SRPL – 400 ft – SWPL – 150 ft – Generation Interconnection line

The Generation Interconnection is south of both 500 kV lines. The maximum tower height for SWPL and SRPL is 158 ft. Even if the SWPL tower fell toward the SRPL tower there would still be spacing between the two towers to avoid collision.

R3: Risk of a conductor from one line being dragged into another line

The risk of a conductor from one line being dragged into another line is similar to having an aircraft fly into both lines. In the case of the alternative path, there is a history of flight related incidents in the shared path. The details of these instances can be found in R5.

R4: Risk of lightning strikes tripping both lines

From SDG&E's data, there has been one outage caused by a lightning strike. This outage occurred on the same portion of the line where the alternative path passes as well. According to outage data, the lightning strike occurred on Tower 50220 in Segment 1 of the route. Other than this outage, there have been no known lightning strikes that have taken place within the shared right of way. As stated previously in the report, the lightning density in the proposed shared right of way is relatively low with a density of 0 - 0.25 flashes/square km/per unit time.

The maps shown in Figures 15 and 16 represent the lightning flash density in California from the years 1989-1996 [Ref 5]. The area marked Imperial Valley is where the corridor will lie. As shown, the IV area has 0 - 0.5 flashes/square km/year.

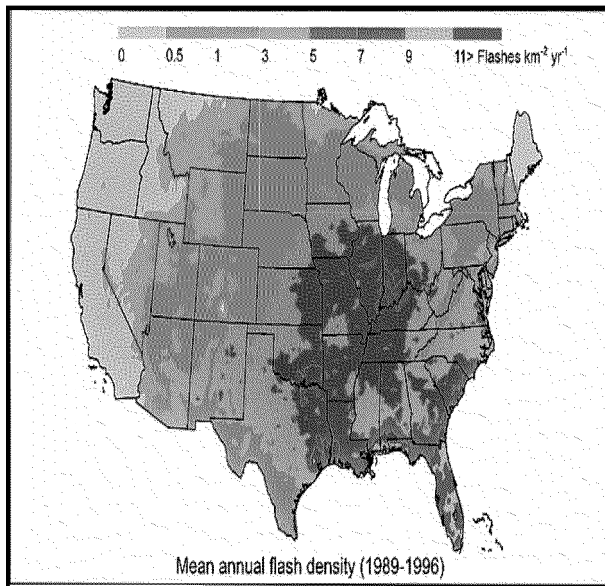

Figure 15: Flash Density (1989-1996)

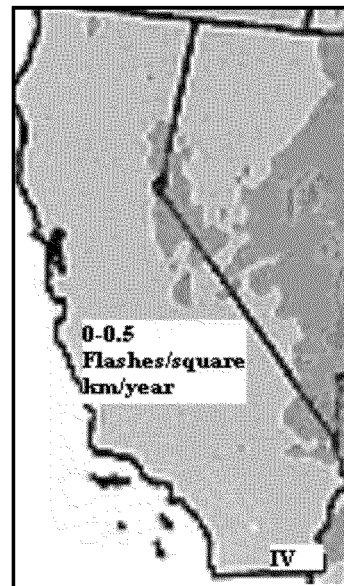

Figure 16: IV Flash Density (1989-1996)

The map shown in Figure 17 was referenced from the Palo Verde Hub to North Gila Lines Report created by APS [Ref 6]. Since this map shows lightning density from 1995-2004, it was also included. As it can be seen from the map shown below, the flash density is 0 - 0.25 flashes/square km/year.

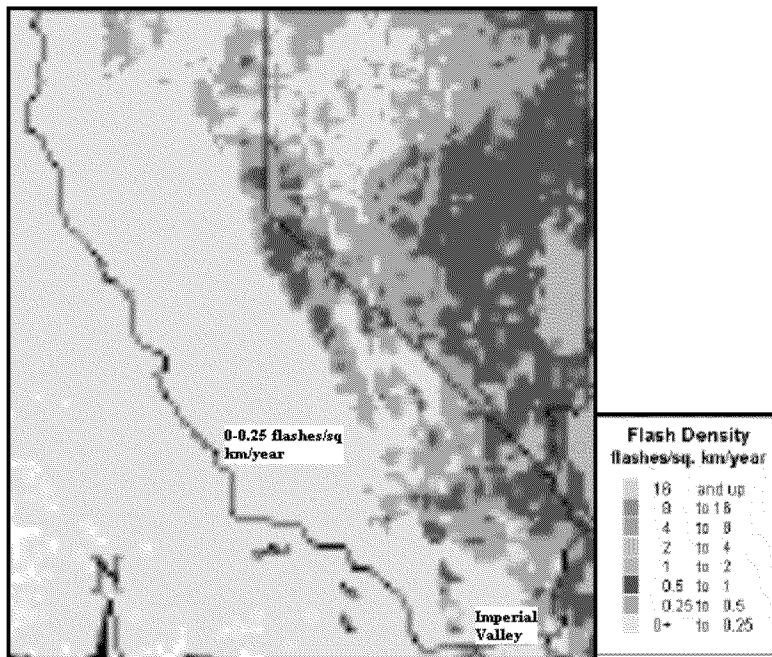

Figure 17: APS Flash Density 1995-2004

The flash density at Imperial Valley in either Figure 7 or 8 is the lowest flash density in comparison to the rest of the United States, making the probability of a lightning strike in the area low.

R5: Risk of an aircraft flying into both lines

There have been flight related incidents that have occurred on the alternative path, making the risk for a double line outage moderate. The alternative path in comparison with the proposed path, tends to directly parallel TL 50001 for 36 miles, which is a greater distance than the proposed path. These flight incidents occurred soon after SWPL was built over 20 years ago and since that time SDG&E has worked to ensure additional incidents do not occur. Aerial marker balls are now present on a portion of the Imperial Valley – Miguel line, which serve as line detectors to warn pilots of the transmission lines. The lines also meet FAA criteria for height regulations.

The first incident happened on the morning of June 14, 1985 when a Border Patrol Pilot failed to gain altitude to clear the power lines, and crashed into the Imperial Valley - Miguel line. This incident took place only a year after the line was put in service. It occurred in Imperial County, 100 yards north of the Southern Pacific Railroad tracks. The second incident that took place occurred on October 24th 1988. This happened on a training flight during a joint drug interdiction mission. The helicopter in route snagged a power line while en route, and exploded into a hillside in western Imperial County. This incident occurred approximately four years after the line was put in service in 1984. Both of these incidents took place within the shared segment of the alternative path route.

Potential Flight Obstacles:

Airport Location: The Imperial County Airport is a small regional airport with feeder service into the Los Angeles International Airport. It is located approximately 4 miles north of downtown El Centro and 94 miles east of San Diego.

Military Airport Location: There is a military airport within Imperial, CA. The Naval Air Facility is 10 miles east of Imperial located in El Centro, CA. All military training is conducted within the confines of restricted airspace within which neither the SWPL or SRPL lie. Otherwise, military flight routes are generally conducted at high altitudes. Military helicopters, however, may fly at lower altitudes and do not adhere to any specific flight route. SDG&E foresees a low probability of an incident occurring because of the aerial marker balls on the line, as well as the historical data indicating that no plane crashes have taken place on the shared right of way in the past 10 years.

En-route: The transmission lines are well below any criteria to be considered as an obstacle to an en-route IFR (Instrument Flight Rules) airway and are not located in any common corridor for visual operation.

Aerial Crop Dusting Application: The corridor is primarily located to the southeast of areas of vegetation. Since the area is surrounded mostly by desert terrain, crop dusting can be eliminated as a risk factor. Also, the lines are within FAA allowable minimum height limits.

Since the area surrounding the shared right of way is unpopulated desert terrain, there are no altitude restrictions for aircrafts, but based on the information listed above, there is enough significant data to conclude that aircraft would not pose a hazard for the shared right of way. The lack of vegetation eliminates the risk of aerial crop dusting. The lines are also marked with aerial marker balls on a portion of the Imperial Valley – Miguel line to help pilots detect the lines, and from the lack of incidents in the past it can be concluded that there is minimal risk of an aircraft flying into both lines in the corridor.

R6: Risk of station related problems resulting in the loss of two lines for a single event

The Imperial Valley 500kV bus is designed to operate as breaker-and-half, in ultimate configuration. Currently, the bus is being operated as a ring bus. When the new 500kV Sunrise Powerlink line is installed the bus will be reconfigured to operate as a combination breaker-and-half and double-breaker-double-bus. This configuration will increase the bus reliability in a stuck breaker contingency and can be seen in Appendix A5. For a single breaker failure to take out both 500 kV lines under either configuration, there would need to be a breaker out for maintenance followed by a breaker failure.

The existing Imperial Valley - Miguel line is protected by three primary-grade, piloted protection systems. The following equipment is used: 1) SEL-421 distance / over-current relays communicating over power line carrier, using three-phase Mode 1 coupling. The power line carrier transmit/receive equipment is RFL-9780; 2) GE L-90 line differential/distance/over-current relays communicating over digital microwave; and 3)

SEL-311L line differential/over-current relays communicating over digital microwave. In addition, transfer trip is provided using RFL-9780 (power line carrier) and RFL-9745 (microwave) teleprotection units.

At this point, SDG&E plans to install a similar protection system for the Imperial Valley - Central 500 kV line as discussed above, with the understanding that communication options are still under discussion. The three protective relays shown above would be applied, and two diverse communication paths will be incorporated, with power line carrier, digital microwave and fiber optic being the communication systems under discussion.

The Miguel substation terminates the Imperial Valley - Miguel line with two 500/230 kV transformers. The Miguel substation is configured as a ring bus. Therefore, a fault on the either Miguel transformer would not cause an outage to the Imperial Valley - Miguel line.

The initial proposed configuration for the Central substation would be similar to the Miguel substation with a ring bus and two 500/230 kV transformers. Again a fault on either Central transformer would not cause an outage of the Imperial Valley - Central line.

R7: Risk of natural disasters (ice, wind, snow or earth slides, flood, etc.) affecting both lines

The climate in the Imperial Valley area is typical of desert conditions, where it is mostly hot and dry (25 percent average relative humidity). Temperatures range from the low mid 30's in January to highs of 110 in July and August. The average low temperature is around 55 degrees and the average high temperature is 89.6 degrees. There are essentially two seasons for the Imperial Valley area, one being summer and the other winter. The transition periods between these two are very short.

The elevation of most of Imperial Valley is near sea level or below. The Salton Sea is the lowest point at 235 feet below sea level. Due to the terrain, and the climate of Imperial Valley being representative of a desert, it is highly unlikely that there would be a risk of hazardous winter related events occurring. There is also very little moisture, with rainfalls bringing in an average of 2.92 inches of rainfall each year. The maximum precipitation occurs in January with an average of 0.51 inches. This amount of rain is not likely to cause flooding in the area.

There have been three tornadoes that have occurred in the past forty one years in Imperial County with the most recent occurring in 1992, and this tornado was a category F0. The other two took place in the years 1965 and 1972. Both of these occurred long before the SWPL was put in service resulted in little or no damage. The one that occurred in 1965 was a category F1 and the one in 1972 was a category F0. According to the Fujita Tornado Damage Scale, an F0 tornado is typically has wind speeds less than 73 mph. An F1 tornado is between 73 to 112 mph and can cause mild to moderate damage. However, both of these are considered to be weak scaled tornados. There was no SWPL outage associated with the F0 tornado in 1992.

Imperial County is the termination point of the San Andreas Fault. The San Andreas Fault runs from San Francisco southeast to the Imperial Valley, where it fragments into a number of small faults. There have not been any reported transmission line failures due to an earthquake in this area. The map shown in Figure 18 recorded all seismic events for 1932-1996. Each red pixel represents an earthquake [Ref 7]. The surface traces, shown as light blue-green lines, are the major faults in the area. The most prominent fault is the San Andreas Fault which runs from the lower right corner to the upper left hand corner.

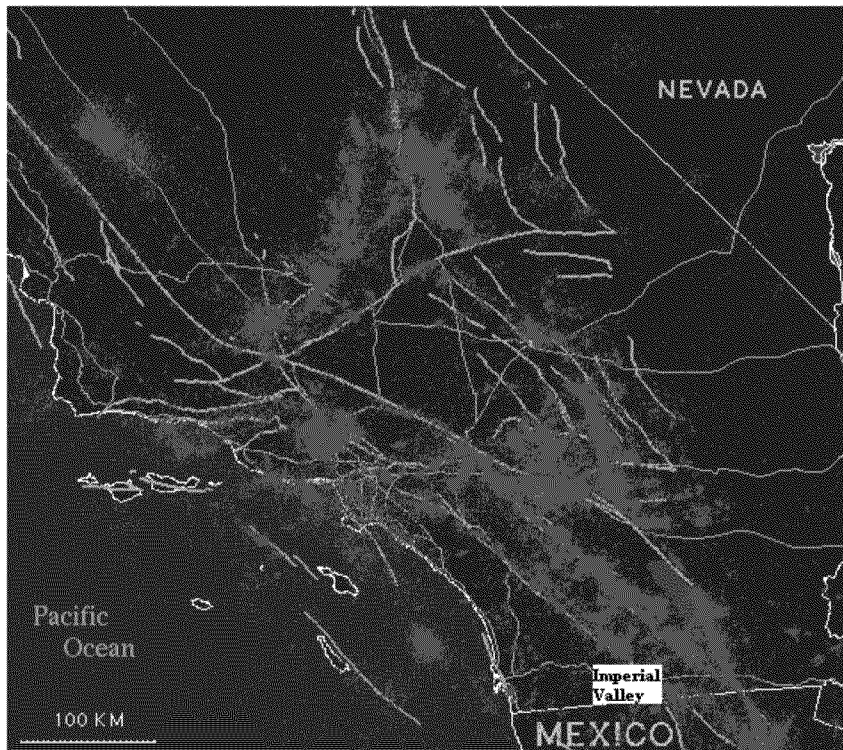

Figure 18: California Earthquakes for 1932-1996

R8: Risk of loss of two lines due to an overhead crossing

There are no existing or proposed overhead crossings within the shared right of way, making this event unlikely. Pictures of the existing line are shown in Appendix A4.

R9: Risk of loss of two lines due to vandalism/malicious acts

There are no known outages that have occurred due to vandalism or malicious acts on the shared right of way. Shooting of insulators would be a typical vandalism related event, but this has not taken place within the alternative path.

R10: Risk of flashover due to vegetation.

The risk of flashover due to vegetation is moderately high in the alternative path. Segment 1 of the route is mostly desert terrain with vegetation consisting primarily of cacti and bushes, neither of which grows above five to ten feet in height. The remaining

two segments of the route tend to pass through areas heavily concentrated by chaparral. Chaparral is one of the most fire-prone plant communities in North America.

Fire is an integral part of the life cycle of the chaparral. The low moisture level in summer and dense concentration of shrubs produce conditions ideal for burning. For this reason, the plants are well adapted to survive fire, and many depend on it to reproduce. A typical chaparral plant community consists of densely-growing evergreen scrub oaks and other drought-resistant shrubs.

Land patrols are performed once every three years and aerial patrols are performed twice a year. The frequency of patrols would aid in the prevention of flashovers that could occur due to vegetation. An example of the typical vegetation through the alternative path is shown below.



Figure 19 - Chaparral Example

Tower 50095, as shown above, occurs in Segment 2 of the alternative path. The separation between this tower and the Imperial Valley – Miguel line is approximately 4 miles at this location. In extreme wind and fire situations, it is possible that the fire could spread to both lines causing an outage. Additional pictures of the towers as well as pictures of the surrounding area can be found in Appendix H.

R11: Risk of a single breaker failure causing loss of two lines

As stated before, the Imperial Valley 500 kV substation will initially be reconfigured to a breaker-and-a-half arrangement and a double bus-double breaker arrangement. This arrangement can be seen in Appendix A5. The Imperial Valley substation is designed for a breaker-and-a-half layout and the double bus-double breaker arrangement may ultimately be configured as a breaker-and-a-half. For a single breaker failure to take out both 500 kV lines under either configuration, there would need to be a breaker out for maintenance followed by a breaker failure.

While such an event is possible, it is a very low probability event (see calculations in Step 3 Section of this report: $P_B = 0.0000458$).

A brief summary of all the risk factors is shown below in Table 6. As previously stated, the results of the alternative path, aside from the Robust Line Design factors, are similar to those from the proposed path. The risk factors in comparison to those from the proposed path show that the risk of a double line outage for the alternative path is greater.

	Risk	Risk Factor
R1	Fire affecting both lines	High Risk
R2	One tower falling into another line	Low Risk
R3	Conductor from one line being dragged into another line	Moderate Risk
R4	Lightening strikes tripping both lines	Moderate/ High Risk
R5	Aircraft flying into both lines	Moderate Risk
R6	Station related problems resulting in loss of two lines for a single event	Low Risk
R7	Natural disasters	Low Risk
R8	Loss of two lines due to an overhead crossing	Low Risk
R9	Loss of two lines due to vandalism/malicious acts	Low Risk
R10	Flashover to vegetation	High Risk
R11	Single breaker failure causing loss of two lines	Low Risk

Table 6: Alternative Path Risk Factor Summary

The alternative path spans from Towers 50281 to 50059. Shown in Appendix H, are pictures of some of the towers within the alternative path. These pictures demonstrate the terrain as well as tower structures.

In consideration of the risk factors associated with the robust line design criteria for the alternative path, SDG&E requests that the RPEWG determine if the alternative path would also qualify for the performance category upgrade to Category D.

Appendix G - Alternative Path Tower Pictures



Tower 50069 – Segment 3

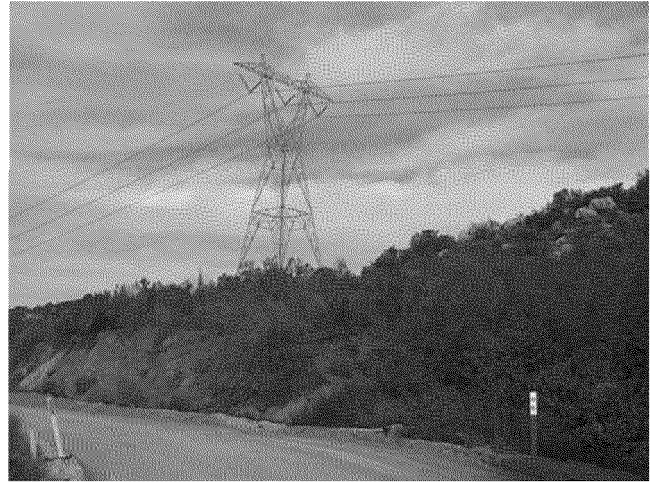

Tower 50071 – Segment 3

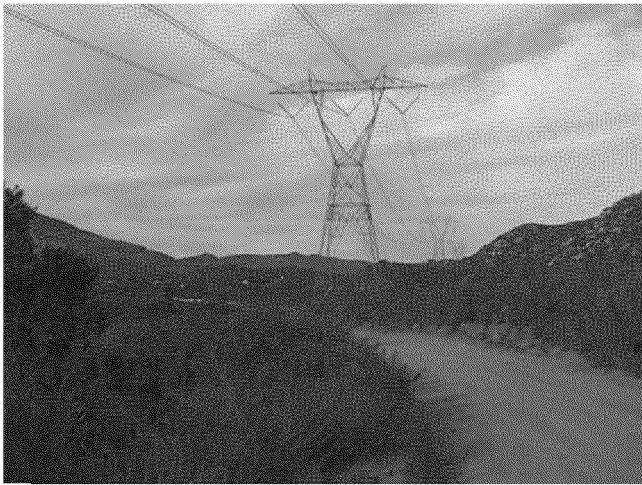

Tower 50076 – Segment 3

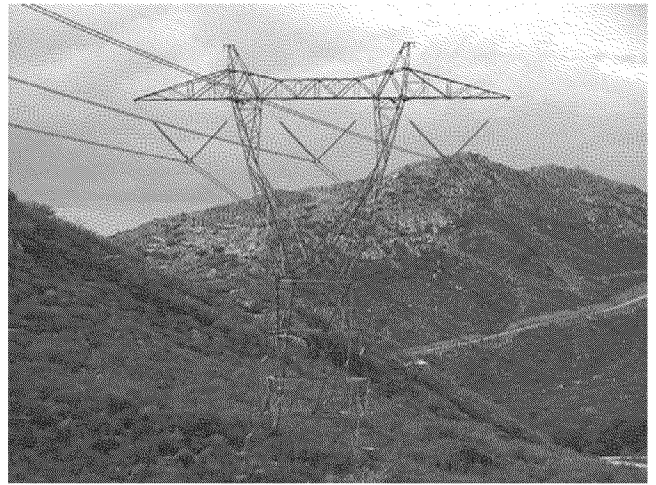

Tower 50088 – Segment 3

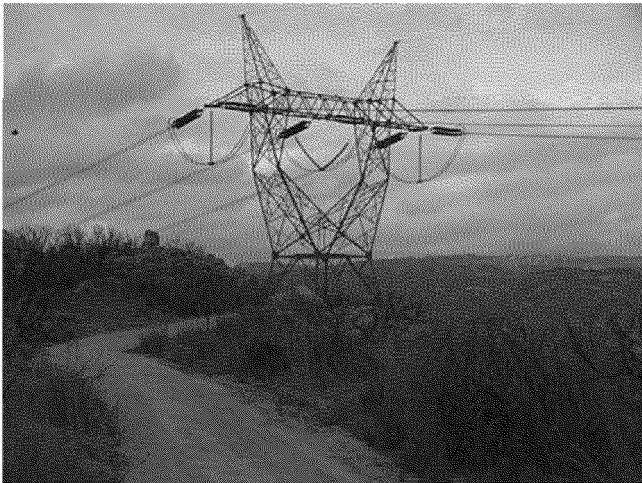

Tower 50102 – Segment 3

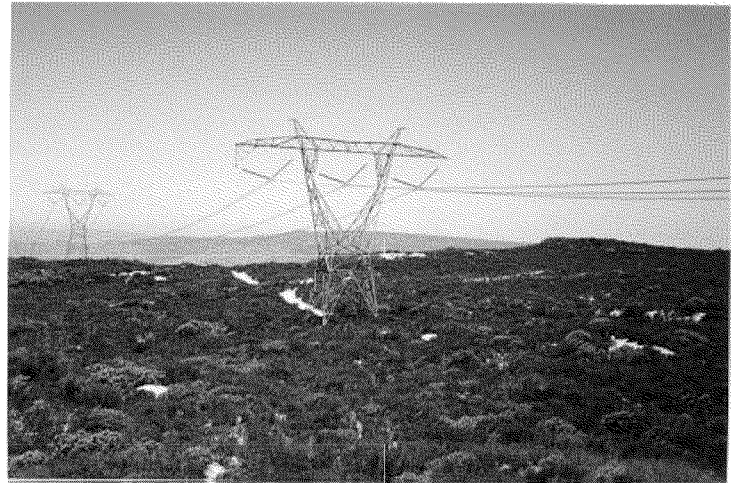

Tower 50119 – Segment 2



Tower 50127 – Segment 2

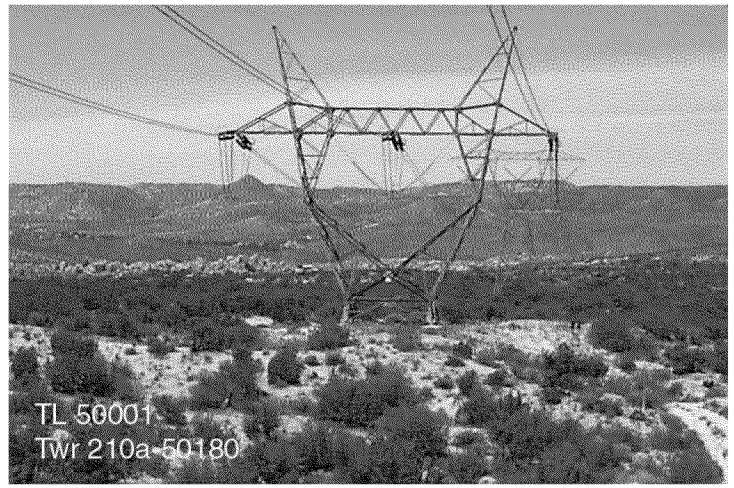

Tower 50180 – Segment 1



Tower 50194 – Segment 1

Appendix H **Powerflow Tables**

VSAT Interface Flow Results - N-2 w/gentrip & crosstrip
with 1300 MVAR of additional VAR support

Contingency N-2 GXtrip		in Base point (1)		
Interface Name	MW Flow	MVAR Flow	MW loss	MVAR loss
Import_1	4194.91	445.69	73.31	821.92
SOS	4194.92	55.00	73.25	817.65
IV GENS	-0.01	0.00	0.00	-14.61
CFE-SDGE	-102.69	-32.27	0.11	-2.86
PV-DV	3816.64	858.38	145.77	1640.69
EOR	7644.56	1004.36	233.54	1877.78
WOR	10632.34	918.33	256.34	1392.24
Path_26	3702.64	480.50	52.33	-327.45
ROA-RUM	84.01	-12.42	0.21	-3.42
ROA-HRA	42.31	-16.00	0.22	-18.97
Path_45	102.80	29.41	0.11	-2.86
PDCI	2523.96	-1440.02	0.00	-4.20
INTMTX	-1600.00	-1111.21	0.00	0.00
IV-ML	OUT OF SERVICE			
Sunrise-BCD	OUT OF SERVICE			
HAA-NG	507.98	14.74	2.59	52.86
ES-TA	-376.52	127.99	15.12	101.83
NG-IV	498.19	-70.24	1.59	-148.21
EPP-ES	66.20	37.36	0.00	-0.16
EPP-SX	444.28	-55.08	4.21	40.46
IV-ROA	102.80	29.41	0.11	-2.86
IV-IID	393.68	64.58	0.00	0.00
SGT-OT	-171.86	17.29	0.12	-21.69
ML-MLMST	OUT OF SERVICE			
ML-MLSXT	OUT OF SERVICE			
ML-MI #1	-102.43	102.80	0.78	-5.02
ML-MI #2	-97.22	104.10	1.02	-5.13
ML-SX	-211.09	70.15	1.15	1.70
ENCTP-SA	-758.28	316.53	4.13	48.66
ENCTP-ES	OUT OF SERVICE			
ENCTP-EN	366.82	-225.05	0.38	1.89
OT-MI	-38.36	50.84	0.03	-0.88
OT-OTTP	130.84	15.47	0.00	-0.07
OTTP-MS	-41.14	54.53	0.03	-0.79
OTTP-SG	-171.86	17.29	0.12	-21.69
TJI-OTAY	OUT OF SERVICE			
OTAY-MLM	185.56	76.49	0.32	0.00
OTAY-MLS	4.92	3.62	0.00	-3.49
PQ-EN	-725.02	119.70	8.46	94.80
PQ-OT	541.78	1.58	2.78	17.69
SA-ENC	OUT OF SERVICE			
SA-MI #1	466.41	-36.33	15.02	105.70
SA-MI #2	466.41	-36.33	15.02	105.71
SO-SA #1	OUT OF SERVICE			
SO-SA #2	-1143.32	184.82	21.97	249.56
SO-SA #3	-1106.66	178.60	21.25	241.14
SX-MLSX	-4.92	-14.27	0.00	-7.16
SO-TA #1	-419.35	57.58	2.18	15.85
SO-TA #2	-419.35	57.58	2.18	15.85
IV xfmr1	99.13	59.53	0.04	3.02
IV xfmr2	198.74	9.21	0.03	4.48
ML XFMR1	-0.09	176.55	0.01	2.53
ML XFMR2	0.09	167.05	0.04	3.25
ML XFMR	-0.10	173.96	0.03	0.91
OTAY	190.70	85.54	0.22	5.44
PEN	187.38	138.76	0.19	10.52
ENCINA	76.57	269.07	0.23	8.46
Devers_SVC	0.00	972.49	0.00	0.00

VSAT Interface Flow Results - N-2 w/gentrip & crosstrip
with no additional VAR support

Contingency N-2 GXtrip 400MW in Base point (1)

Interface Name	MW Flow	MVAR Flow	MW loss	MVAR loss
Import_1	3784.44	328.42	64.20	718.27
SOS	3784.45	-47.25	64.14	714.17
IV GENS	-0.01	0.00	0.00	-14.59
CFE-SDGE	-111.24	-27.28	0.13	-2.71
PV-DV	3792.30	964.79	146.46	1655.57
EOR	7668.64	1113.56	235.89	1906.96
WOR	10597.50	1055.65	256.79	1409.73
Path_26	4262.02	504.74	69.59	-198.06
ROA-RUM	88.25	-12.92	0.24	-3.24
ROA-HRA	46.61	-16.56	0.27	-18.58
Path_45	111.36	24.56	0.13	-2.71
SYLMAR1	805.11	-296.65	0.00	0.00
INTMTX	-1600.00	-887.98	0.00	0.00
IV-ML	OUT OF SERVICE			
Sunrise-BCD	OUT OF SERVICE			
HAA-NG	518.72	18.00	2.70	54.16
ES-TA	-339.52	135.31	13.32	88.75
NG-IV	506.13	-67.81	1.65	-147.36
EPP-ES	49.80	35.79	0.00	-0.15
EPP-SX	420.02	-51.85	3.92	37.30
IV-ROA	111.36	24.56	0.13	-2.71
IV-IID	393.01	70.56	0.00	0.00
SGT-OT	-154.53	40.85	0.11	-20.94
ML-MLMST	OUT OF SERVICE			
ML-MLSXT	OUT OF SERVICE			
ML-MI #1	-96.01	101.62	0.75	-4.78
ML-MI #2	-90.96	102.75	0.98	-4.88
ML-SX	-199.70	69.17	1.08	1.35
ENCTP-SA	-675.05	259.65	3.43	40.12
ENCTP-ES	OUT OF SERVICE			
ENCTP-EN	337.07	-76.16	0.26	1.13
OT-MI	-26.32	54.66	0.03	-0.85
OT-OTTP	126.40	-3.24	0.00	-0.07
OTTP-MS	-28.24	58.63	0.03	-0.76
OTTP-SG	-154.53	40.85	0.11	-20.94
TJI-OTAY	OUT OF SERVICE			
OTAY-MLM	178.47	114.84	0.36	0.56
OTAY-MLS	7.56	32.65	0.01	-3.32
PQ-EN	-657.10	169.95	7.59	84.72
PQ-OT	491.97	-46.15	2.43	14.91
SA-ENC	OUT OF SERVICE			
SA-MI #1	424.17	-56.55	13.39	93.68
SA-MI #2	424.17	-56.55	13.39	93.68
SO-SA #1	OUT OF SERVICE			
SO-SA #2	-1034.32	188.39	19.32	219.08
SO-SA #3	-1001.15	182.08	18.69	211.66
SX-MLSX	-7.50	-42.45	0.05	-6.50
SO-TA #1	-378.77	68.59	1.94	14.00
SO-TA #2	-378.77	68.59	1.94	14.00
IV xfmr1	100.69	59.77	0.04	3.10
IV xfmr2	201.89	9.87	0.03	4.63
ML XFMR1	-0.09	169.77	0.01	2.43
ML XFMR2	0.09	160.64	0.04	3.13
ML XFMR	-0.10	167.31	0.03	0.88
OTAY	186.32	154.80	0.29	7.31
PEN	183.93	237.66	0.32	17.46
ENCINA	73.81	273.67	0.26	11.15