

Attachment 2

Lake Elsinore Advanced Pump Storage
(LEAPS)
and
Talega-Escondido / Valley-Serrano
(TE/VS)
Transmission Project

**Why This Project Is The Solution for
SONGS Retirement**

June 2013

The Nevada Hydro Company

Background

- Lake Elsinore Advanced Pump Storage (**LEAPS**) (FERC Project 14227) is a 500 MW advanced pumped storage project located roughly 20 miles from the now-shuttered SONGS facility.
- The Talega-Escondido / Valley-Serrano 500 kV Interconnect (**TE/VS Interconnect**) brings 500 kV transmission less than 10 miles from SONGS.

Projects Have Been Assessed

- Economic and reliability benefits of the project are well known:
 - CAISO has studied a number of times over the years.
 - Nevada Hydro provided expert testimony to PUC.
- CEC identified as critical Statewide resource.

Location

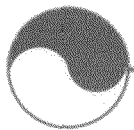
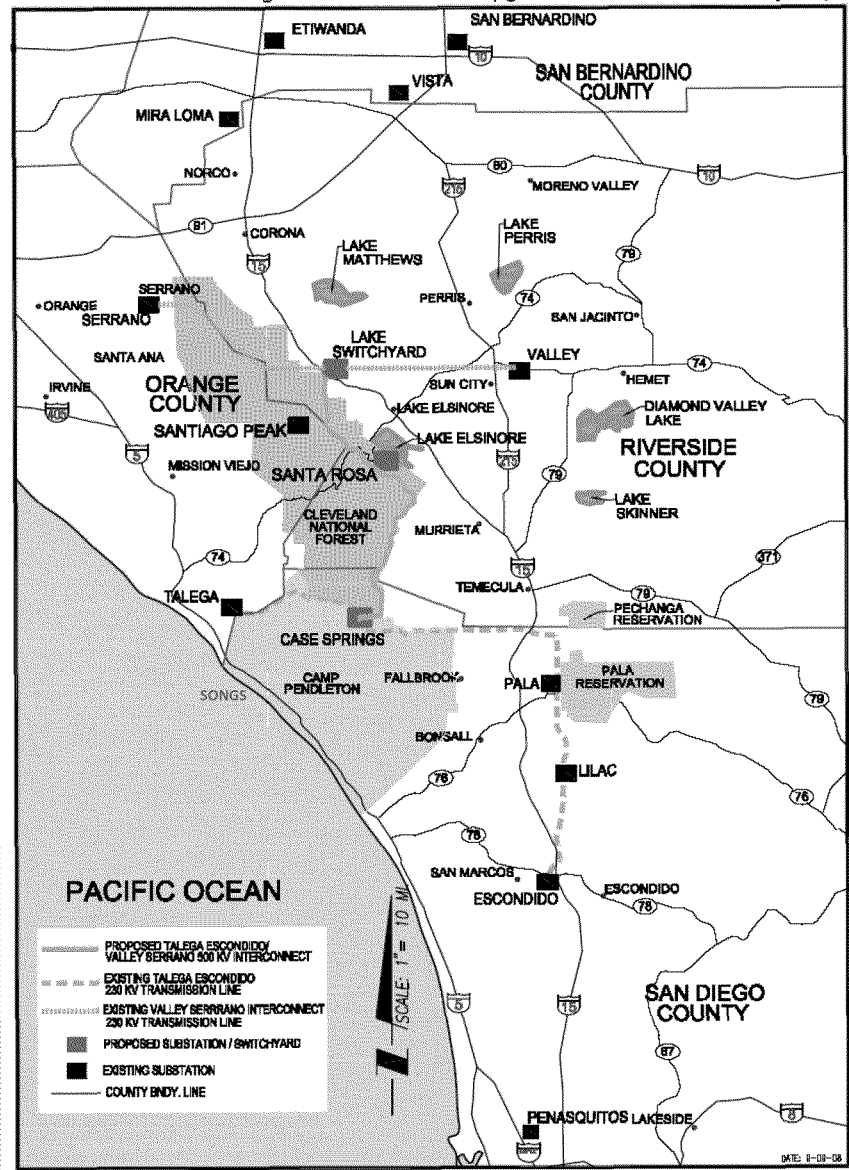

THE NEVADA HYDRO COMPANY, INC.

One-Line Diagram

Lake Elsinore Advanced Pump Storage Project Conceptual Single Line Diagram

Rev. 17 July 98

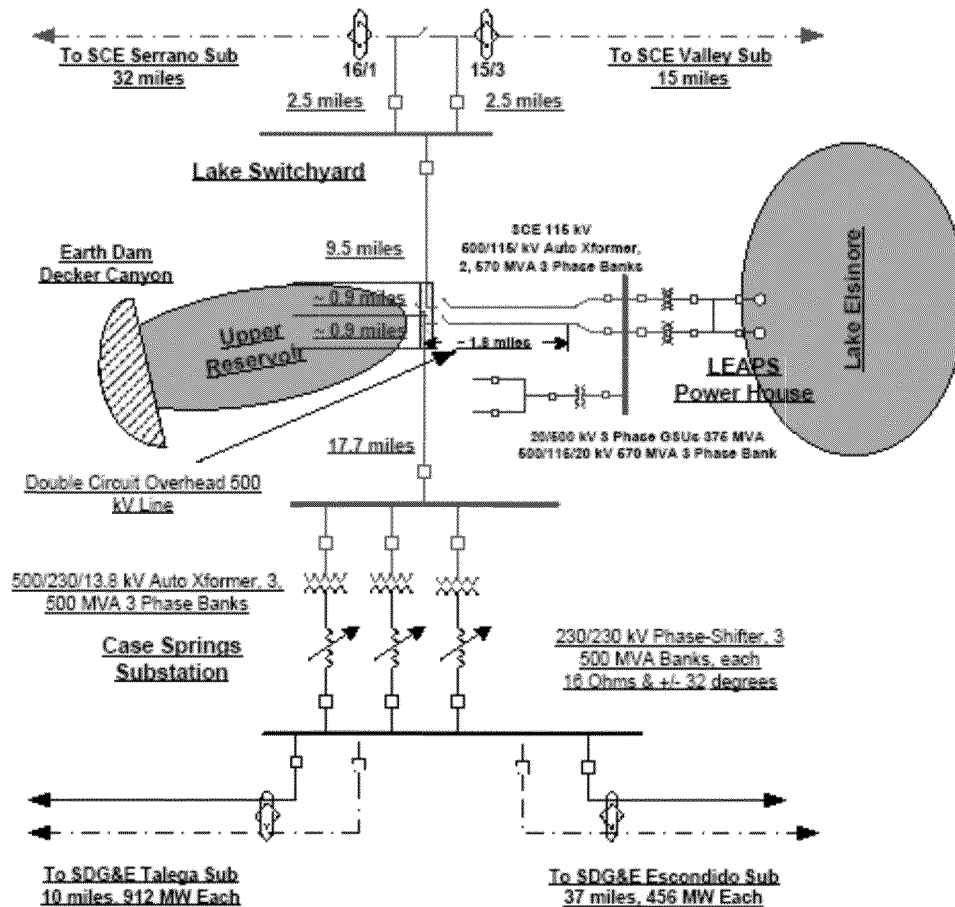

Notes:

1. LEAPS 500 kV Line, conductors double bundled (two per phase) Bluebird 1256 ACSR.
2. Talega - Case Springs 230 kV, single conductor Falcon 1033 ACSR, double circuit
3. Case Springs - Escondido 230 kV, double bundled Falcon 1033 ACSR, double circuit
4. GIL rated at 4000 amps continuous load

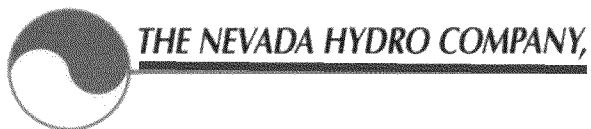

System Map and Connection

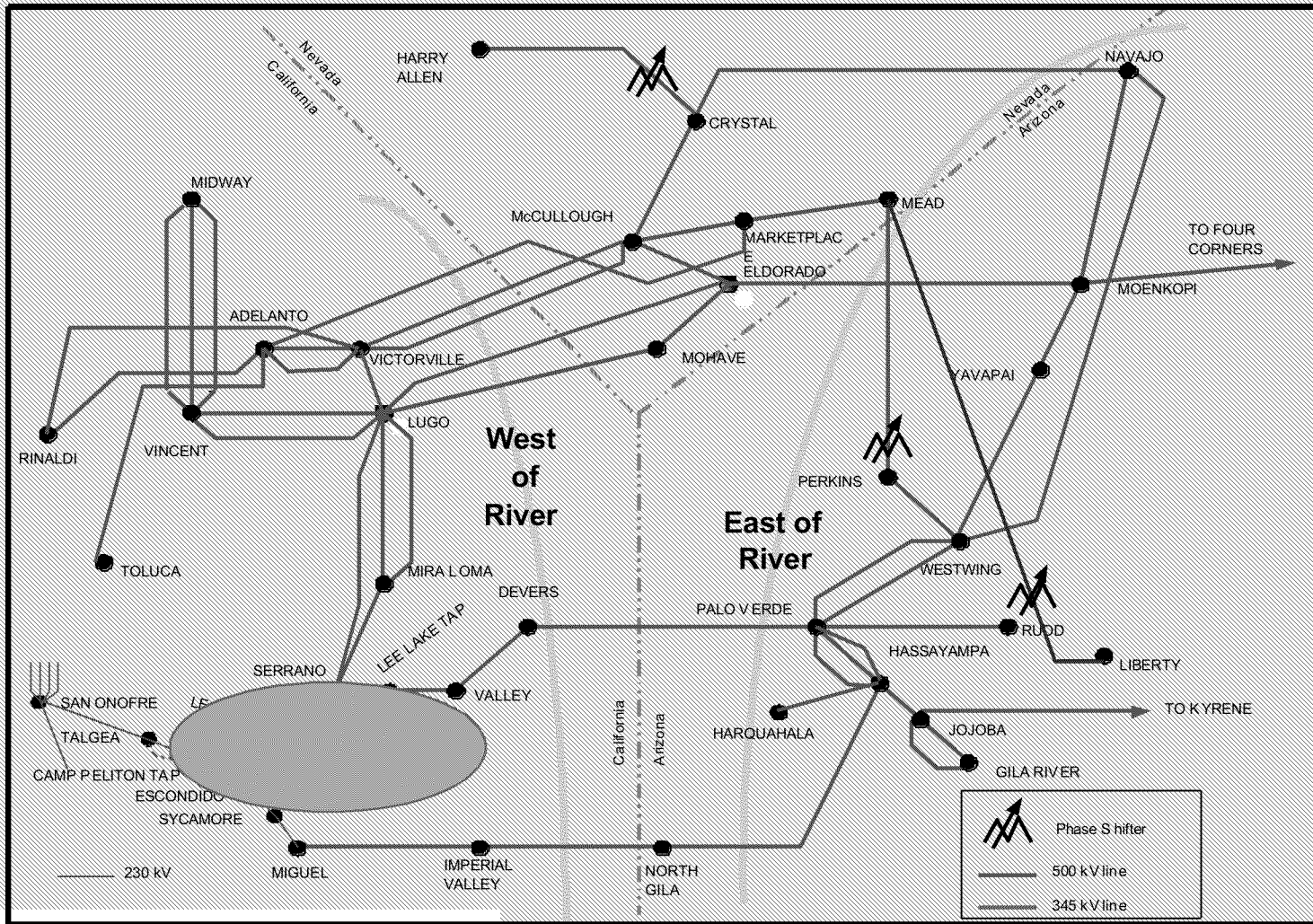

Base TE/VS-LEAPS Plan

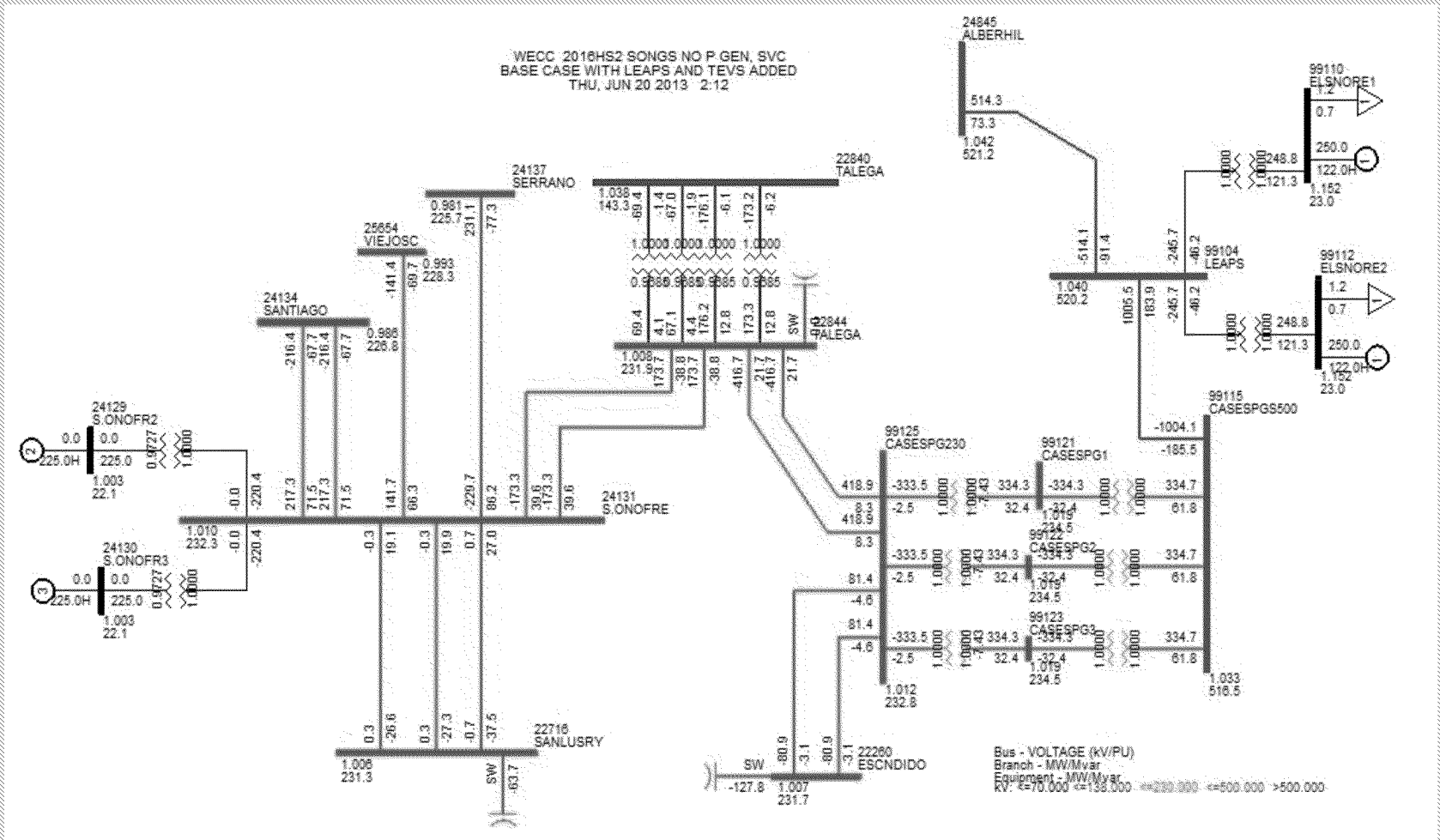

Nevada Hydro Company

Proposed Extension to the TE/VS Interconnect

- As proposed, the TE/VS Interconnect links into the Talaga-Escondido line at the proposed Case Springs substation at 230 kV.
- Proposal extends from Case Springs to the Talega substation at 500 kV rather than at 230 kV.

Extended TE/VS- LEAPS Plan

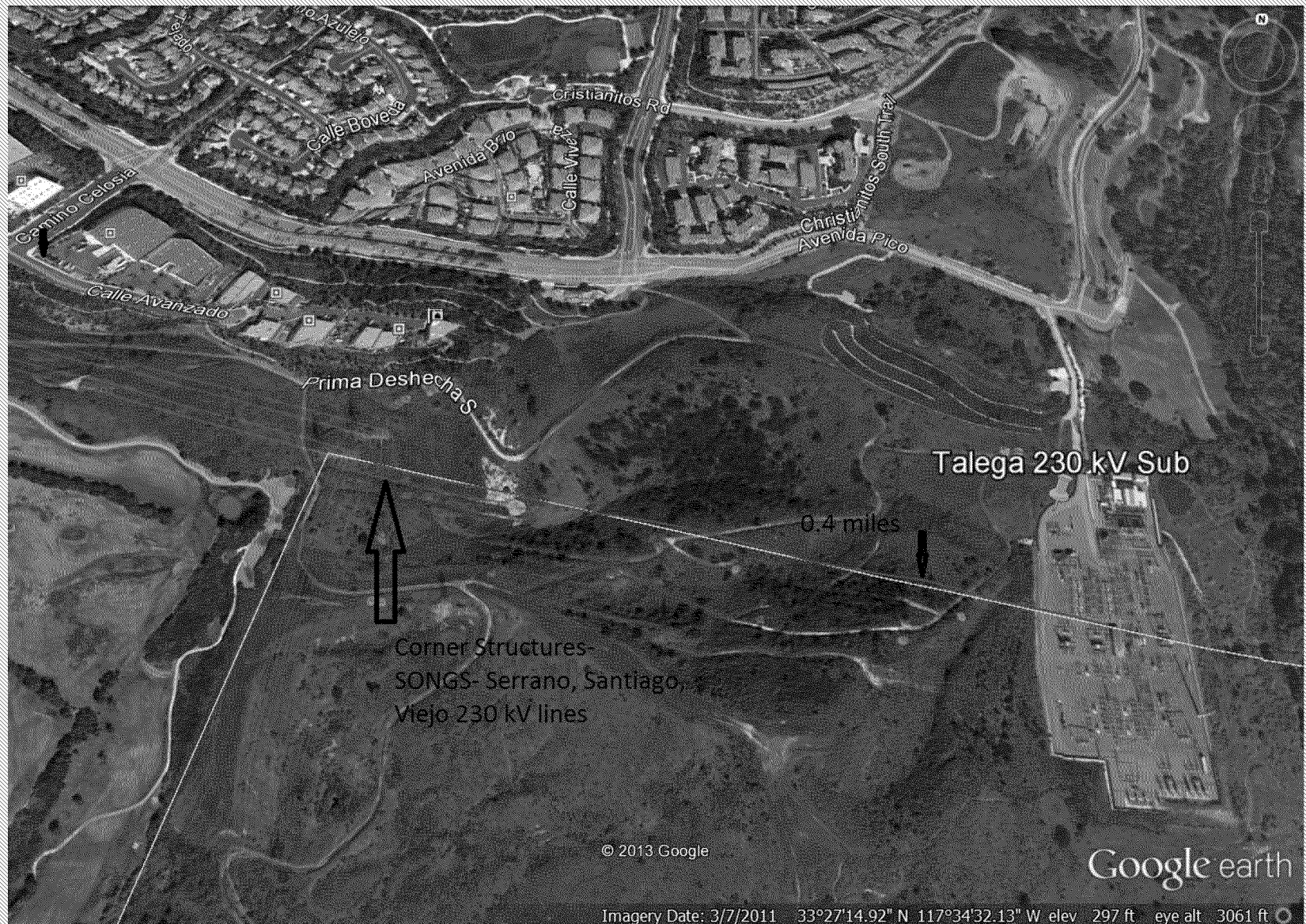

Extended TE/VS- LEAPS Plan

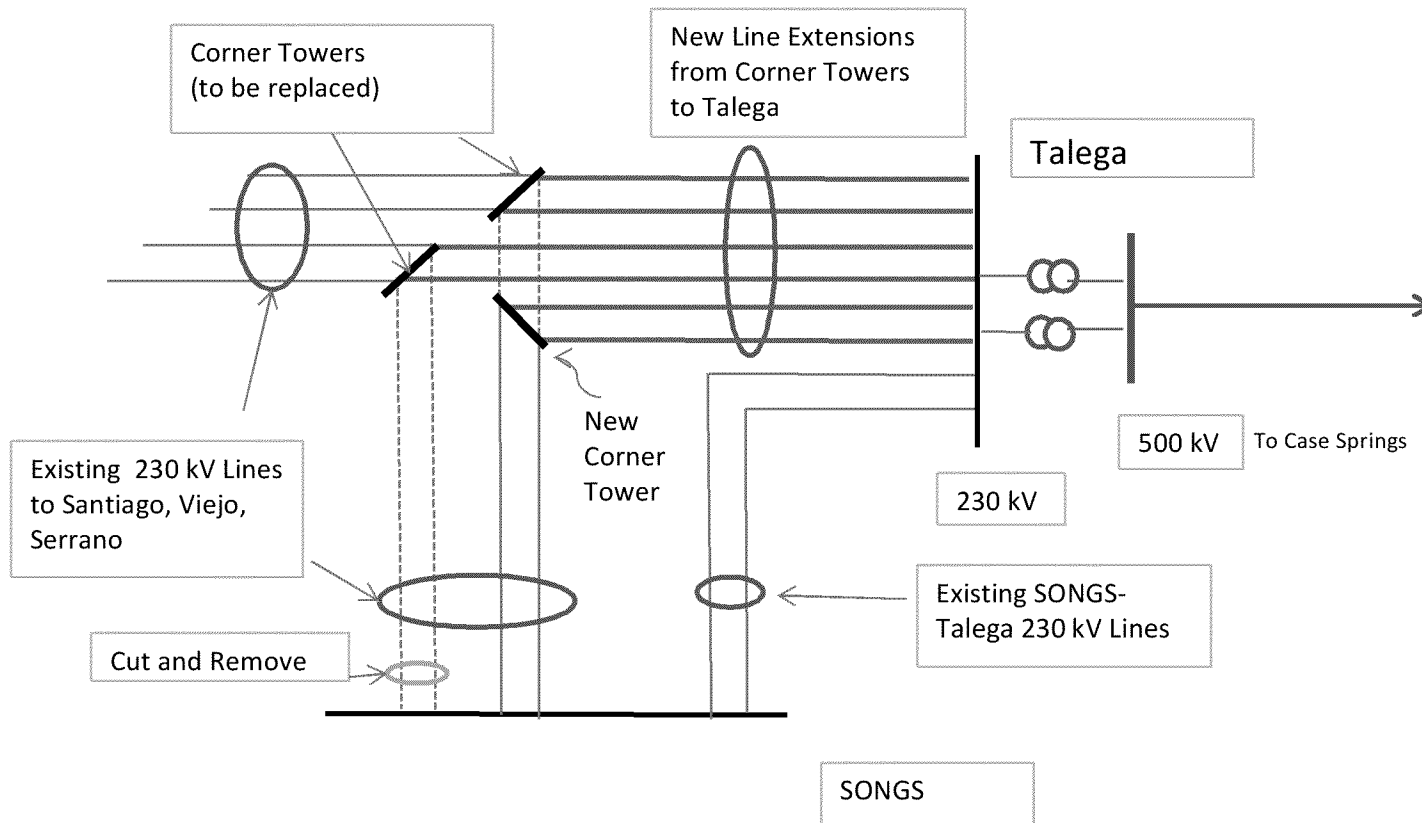

Changes to Re-route SCE 230 kV lines from SONGS into Talega to provide interconnection of 500 kV into L.A. Basin area

Extended TE/Vs- LEAPS Plan

WECC 2016HS2 BASE CASE, SONGS P GEN OFF, SVC
 TEVS LEAPS ADDED, 500 KV TO TALEGA
 THU, JUN 13 2013 15:06

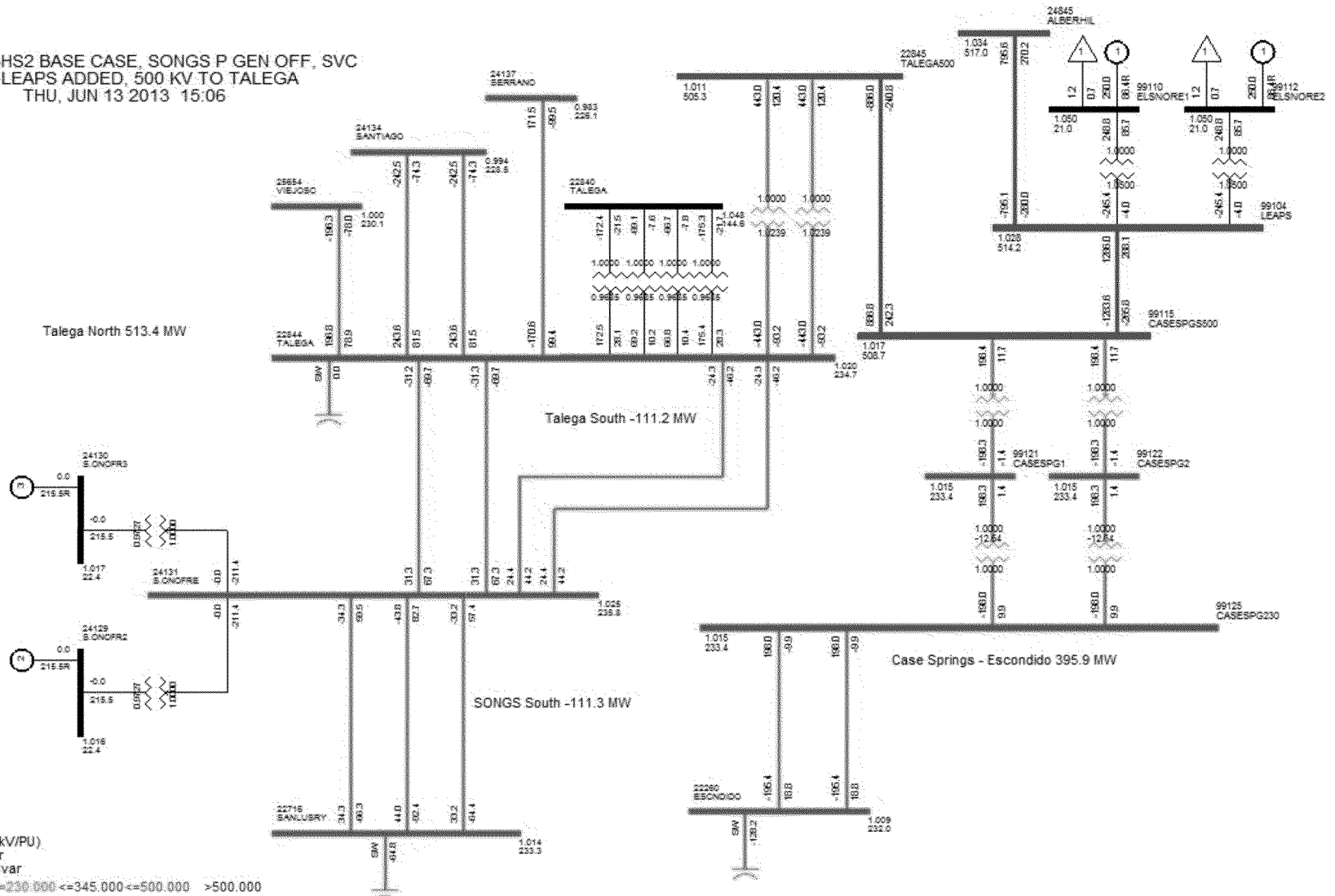

Modeling Assumptions

- 2016 modeling data, without SONGS
- Cases without LEAPS and TE/VS
 - Base Case
 - G-1 (Loss of Otay Mesa) , and N-1 (IV-N. Gila)
 - N-1-1 loss of IV-Miguel and Sunrise

Base Case: SONGS Area

WECC 2016HS2, SONGS NO P GEN, SVC
 BASE CASE, SAME NET TIES AS WECC CASE
 THU, JUN 13 2013 11:23

Bus - VOLTAGE (KV/PU)
 Branch - MW/Mvar
 Equipment - MW/Mvar

KV: <=138.000 <=230.000 <=345.000 <=500.000 >500.000

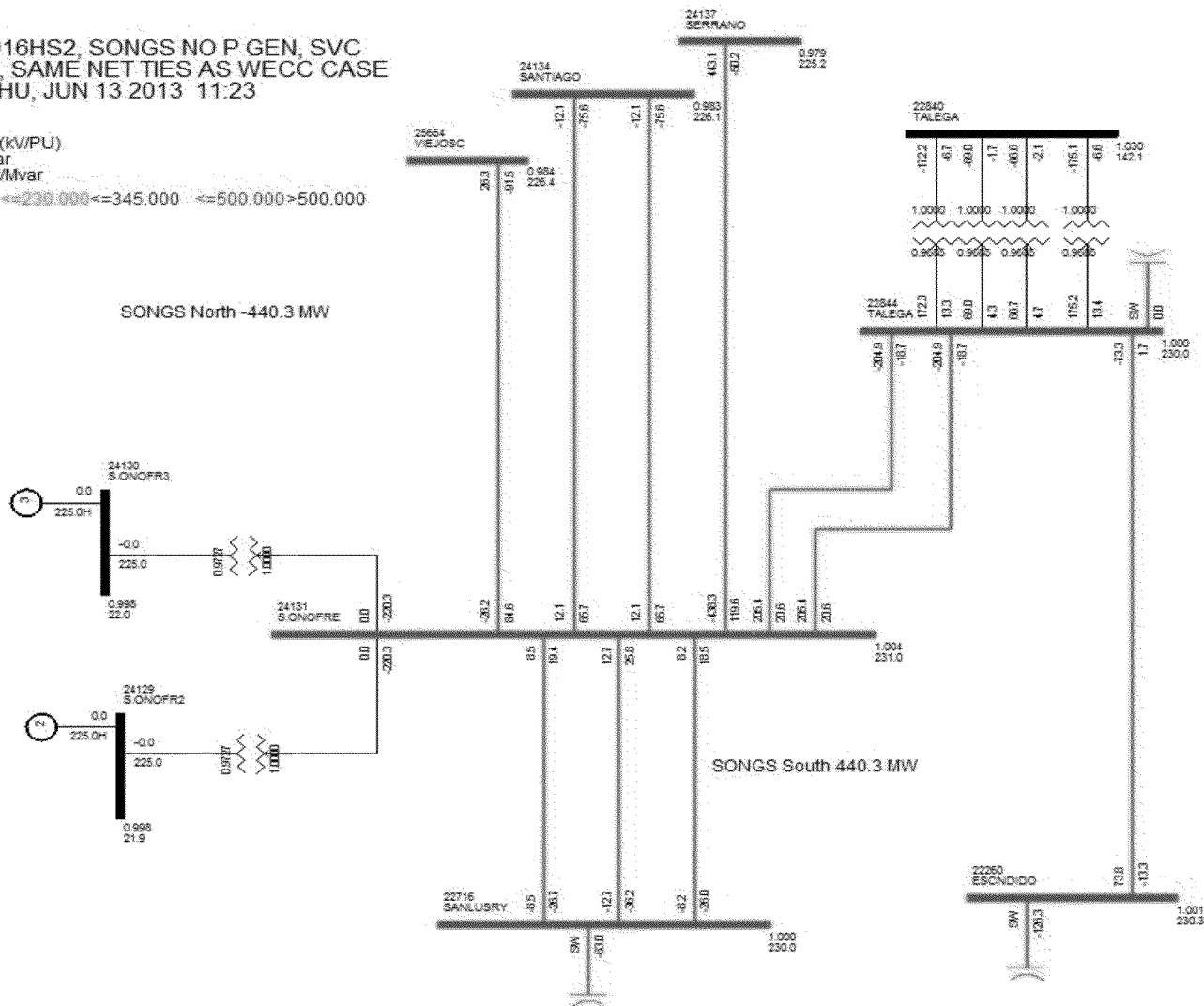

Nevada Hydro Company

Base Case: Imperial Valley (IV) Area

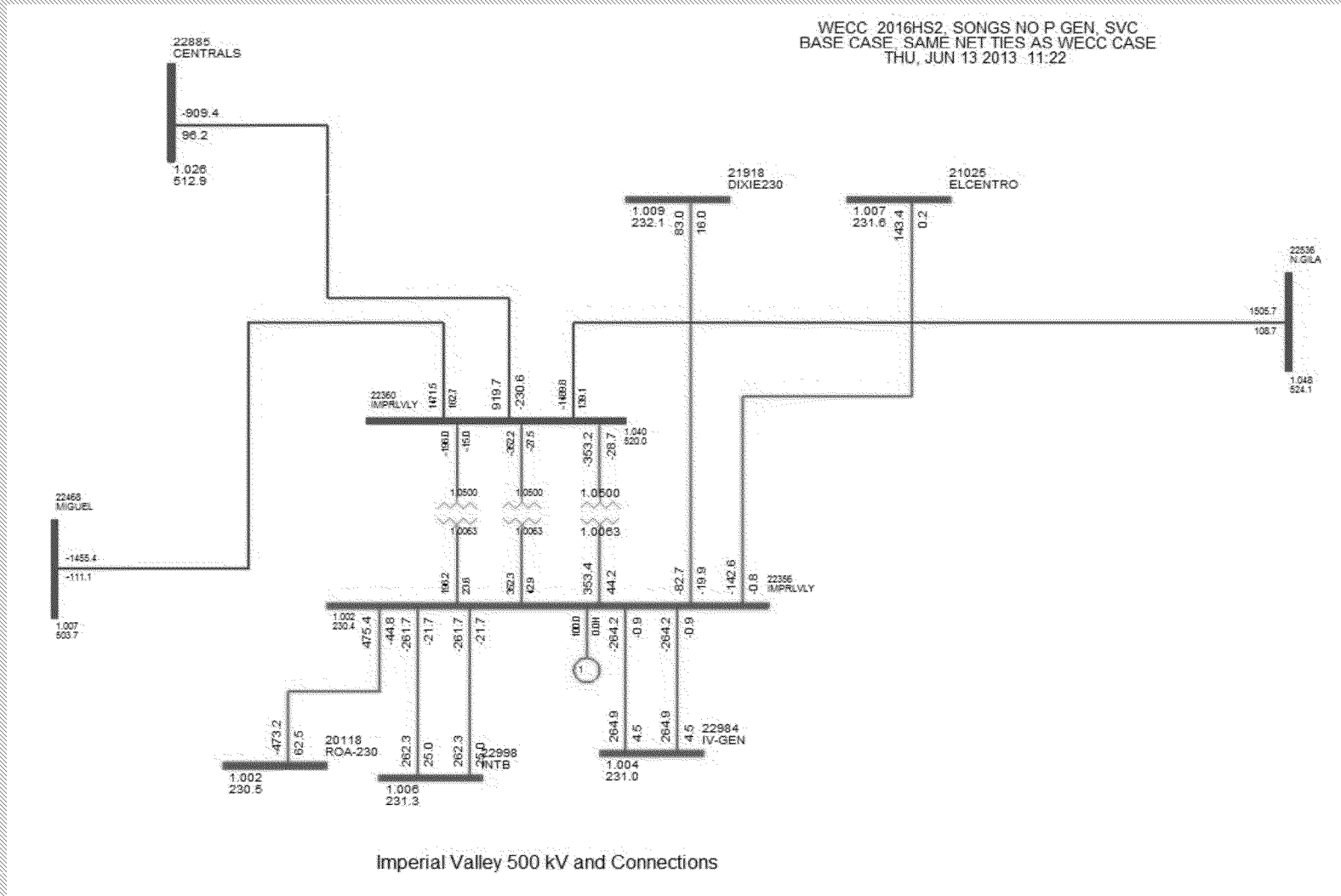

Nevada Hydro Company

Base Case: Serrano Area

WECC 2016HS2, SONGS NO P GEN, SVC
 BASE CASE, SAME NET TIES AS WECC CASE
 THU, JUN 13 2013 11:20

Bus - VOLTAGE (KV/PU)
 Branch - MW/Mvar
 Equipment - MW/Mvar
 KV: <=30.000 <=230.000 <=345.000 <=500.000 >500.000

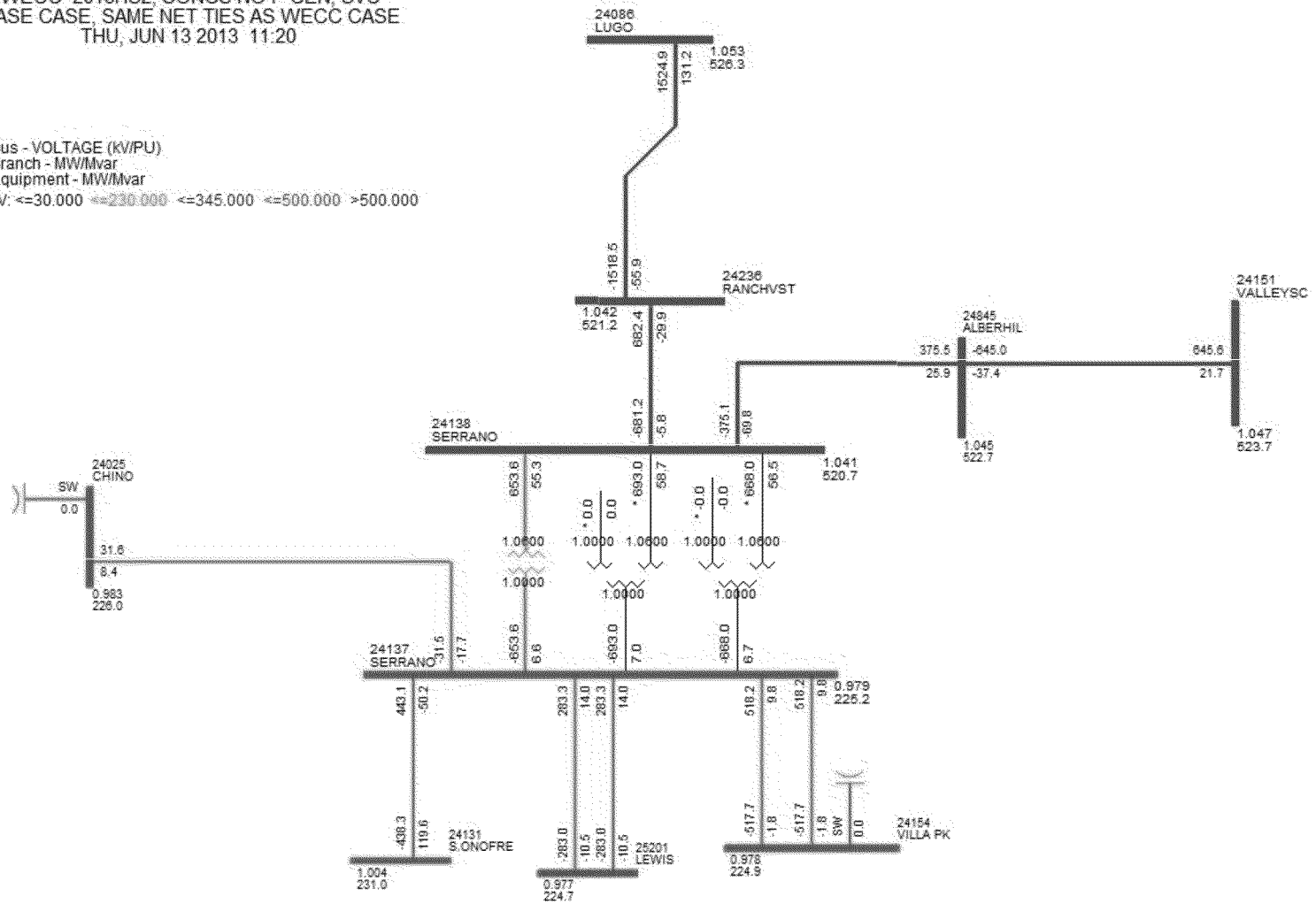

Nevada Hydro Company

N-1-1 on Base Case: Songs Area

WECC 2016HS2, SONGS PGEN 0, SVC
SDGE MAX GEN, N-1-1, IV-MIGUEL, SUNRISE
THU, JUN 13 2013 11:09

Bus - VOLTAGE (kV/PU)
Branch - MW/Mvar
Equipment - MW/Mvar

KV: <=138.000 <=230.000 <=345.000 <=500.000 >500.000

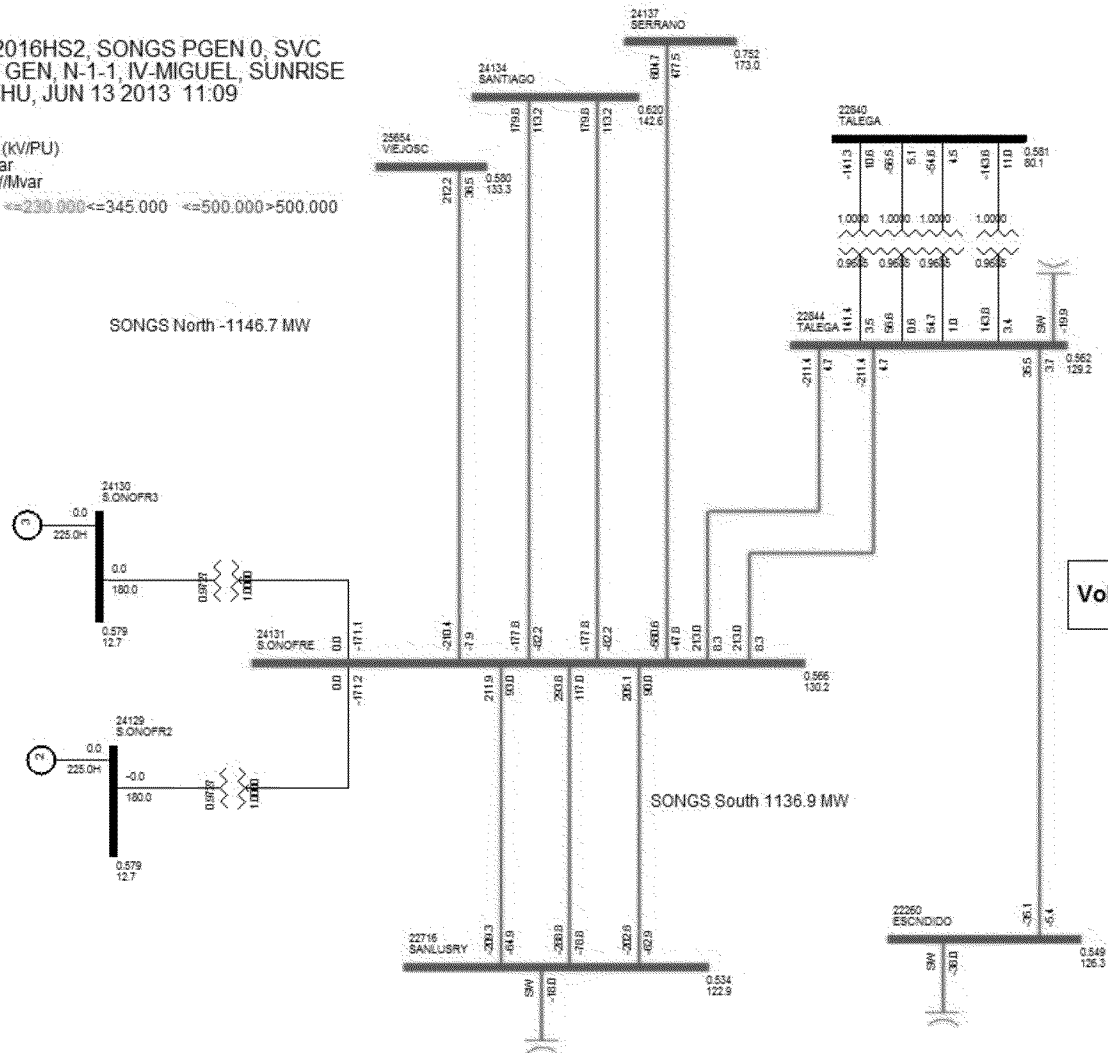

Nevada Hydro Company

N-1-1 on Base Case: Serrano Area

WECC 2016HS2, SONGS PGEN 0, SVC
SDGE MAX GEN, N-1-1, IV-MIGUEL, SUNRISE
THU, JUN 13 2013 11:11

Bus - VOLTAGE (KV/PU)
Branch - MW/Mvar
Equipment - MW/Mvar
KV: <=30.000 <<230.000 <=345.000 <=500.000 >500.000

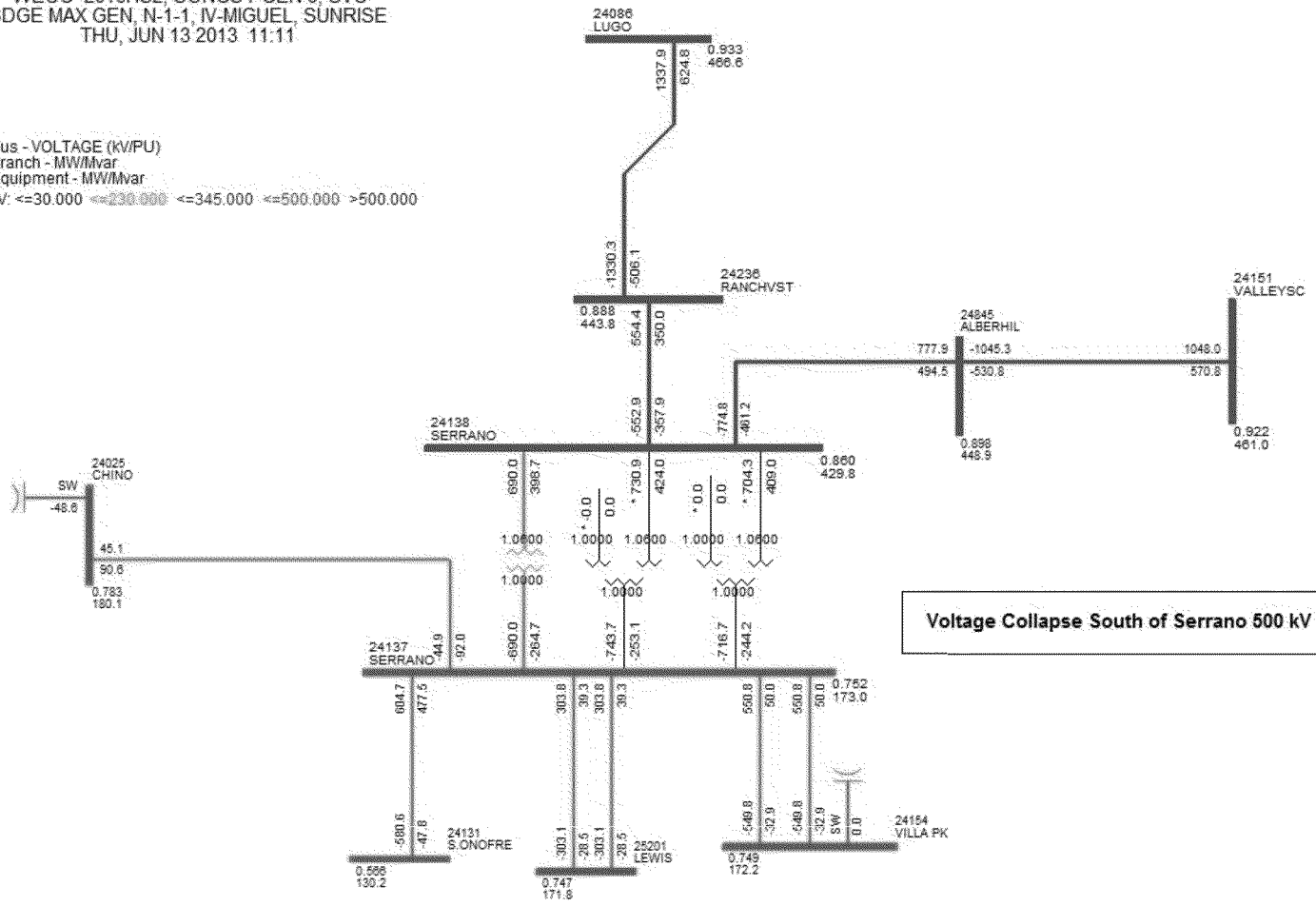

Nevada Hydro Company

N-1-1 on Base Case: (IV) Area

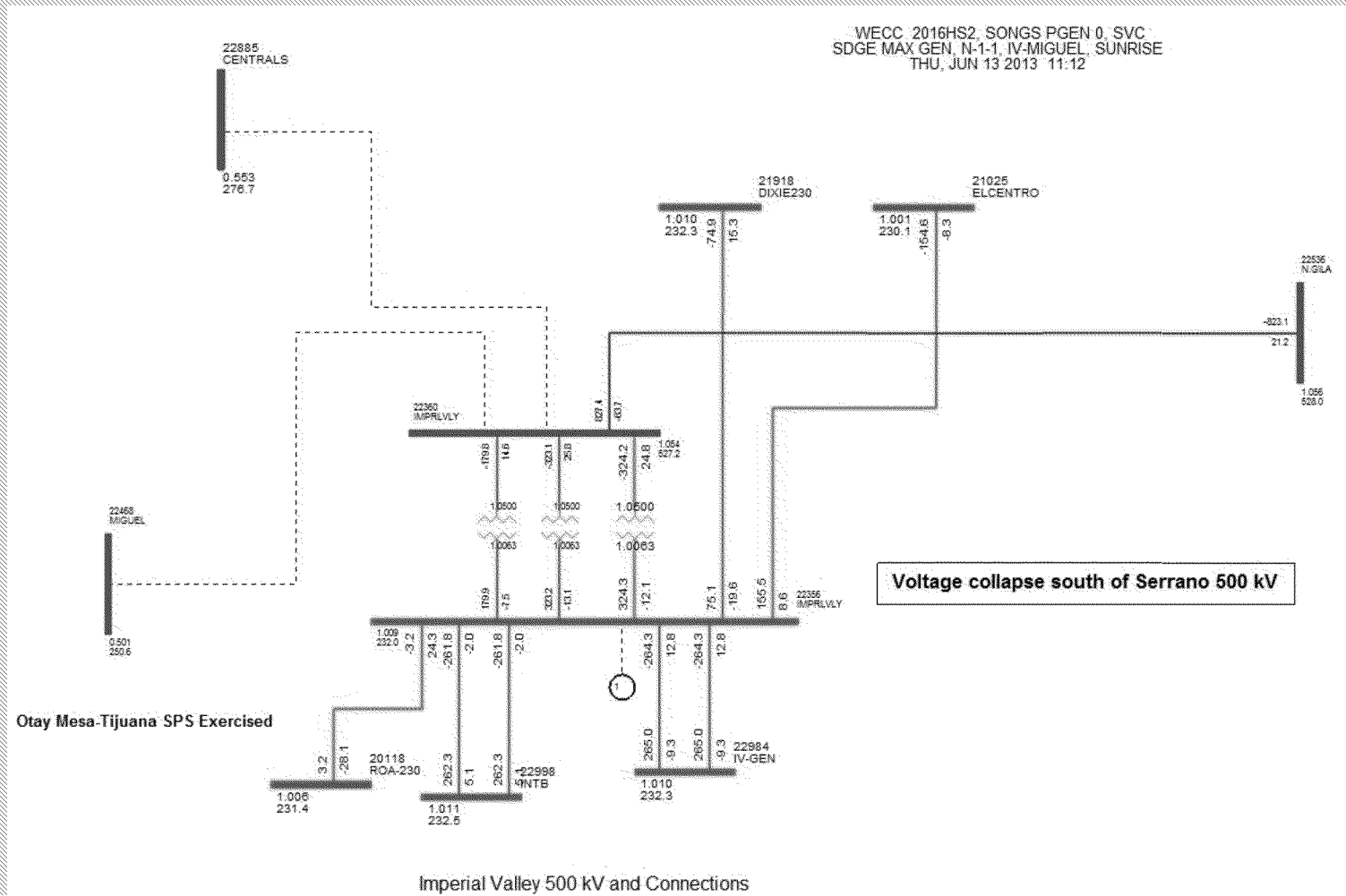

Nevada Hydro Company

San Diego High Gen, G-1 (Otay)

SONGS Area

WECC 2016HS2, SONGS NO P GEN, SVC
 SDGE MAX IN- BASIN GEN, G-1 OTAY MESA
 THU, JUN 13 2013 12:36

Bus - VOLTAGE (KV/PU)
 Branch - MW/Mvar
 Equipment - MW/Mvar
 KV: <=138.000 <=230.000 <=345.000 <=500.000 >500.000

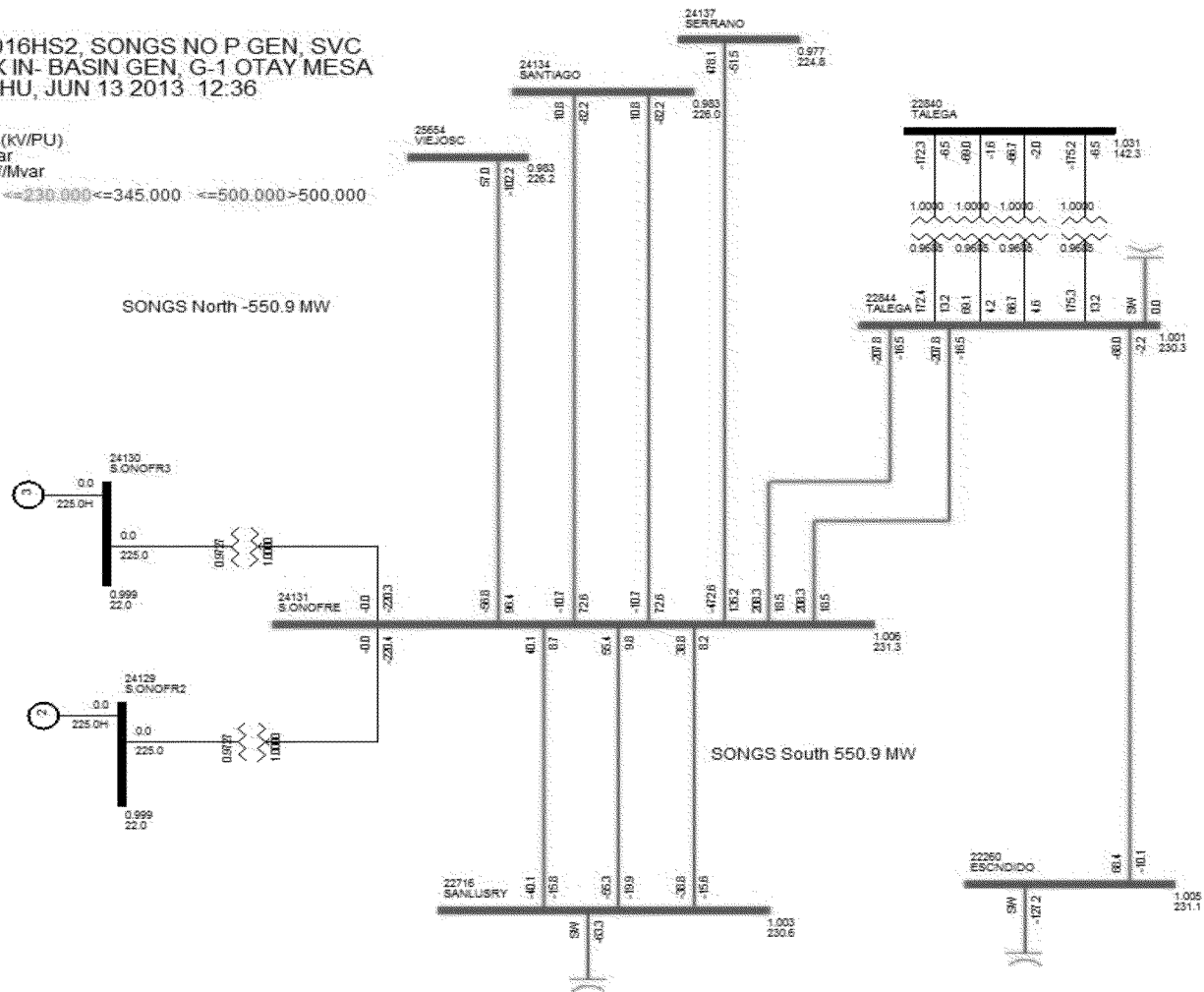

Nevada Hydro Company

San Diego High Gen, G-1 (Otay)

Serrano Area

WECC 2016HS2, SONGS NO P GEN, SVC
 SDGE MAX IN- BASIN GEN, G-1 OTAY MESA
 THU, JUN 13 2013 12:35

Bus - VOLTAGE (KV/PU)
 Branch - MW/Mvar
 Equipment - MW/Mvar
 KV: <=30.000 <=230.000 <=345.000 <=500.000 >500.000

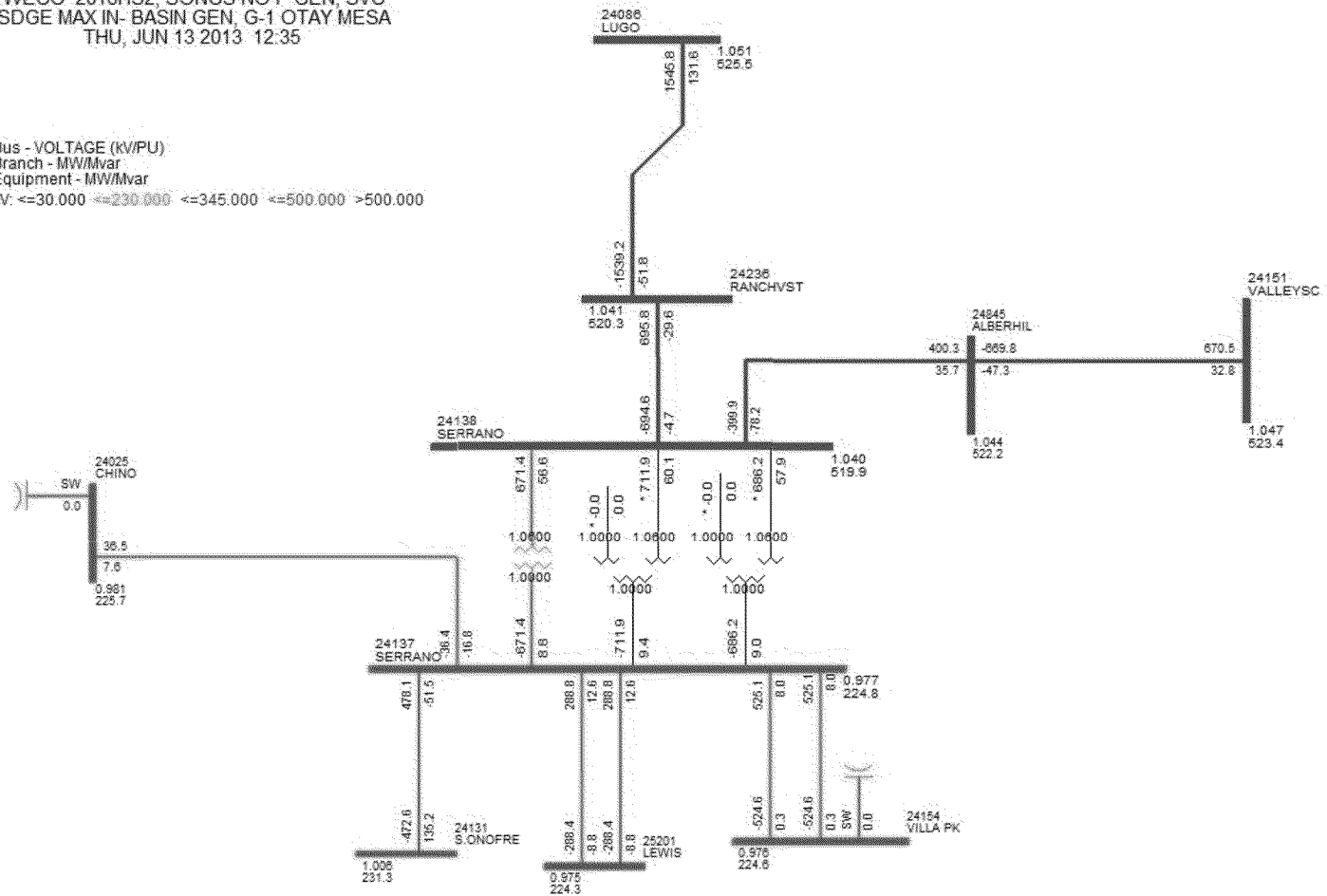

Nevada Hydro Company

San Diego High Gen- G-1 (Otay) IV Area

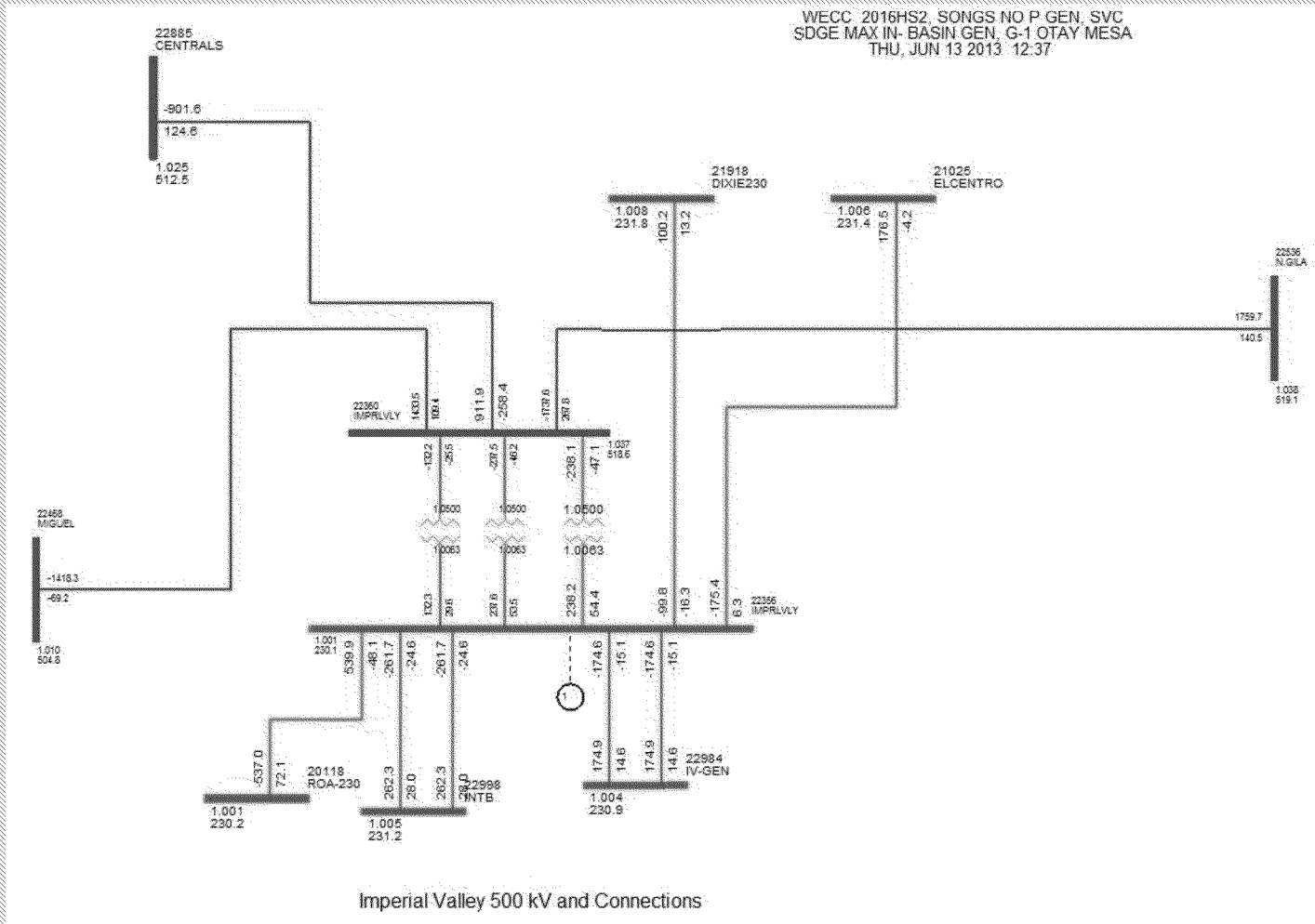

Nevada Hydro Company

San Diego High Gen, G-1,N-1 (IV-N. Gila) SONGS Area

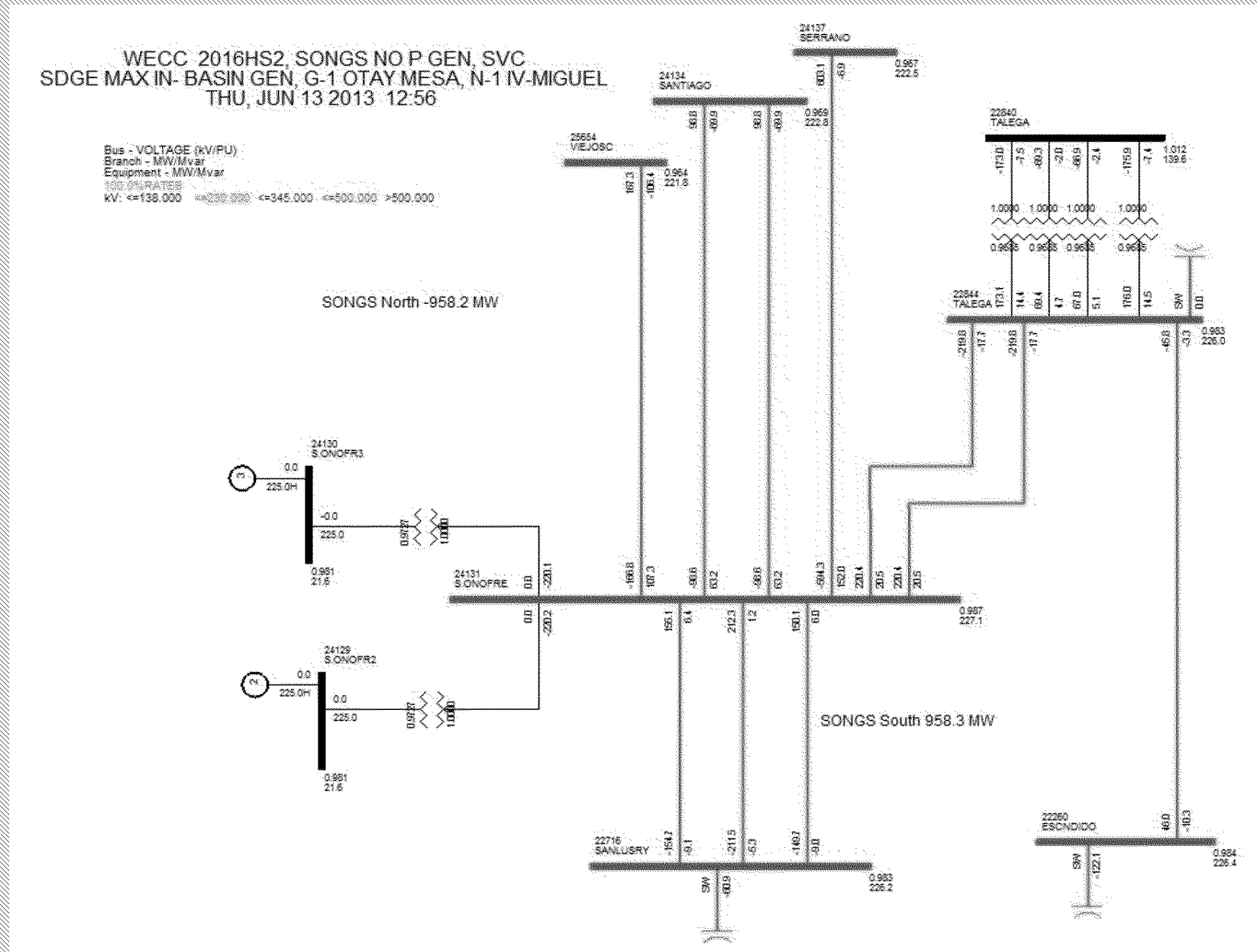

Nevada Hydro Company

San Diego High Gen, G-1, N-1 Serrano Area

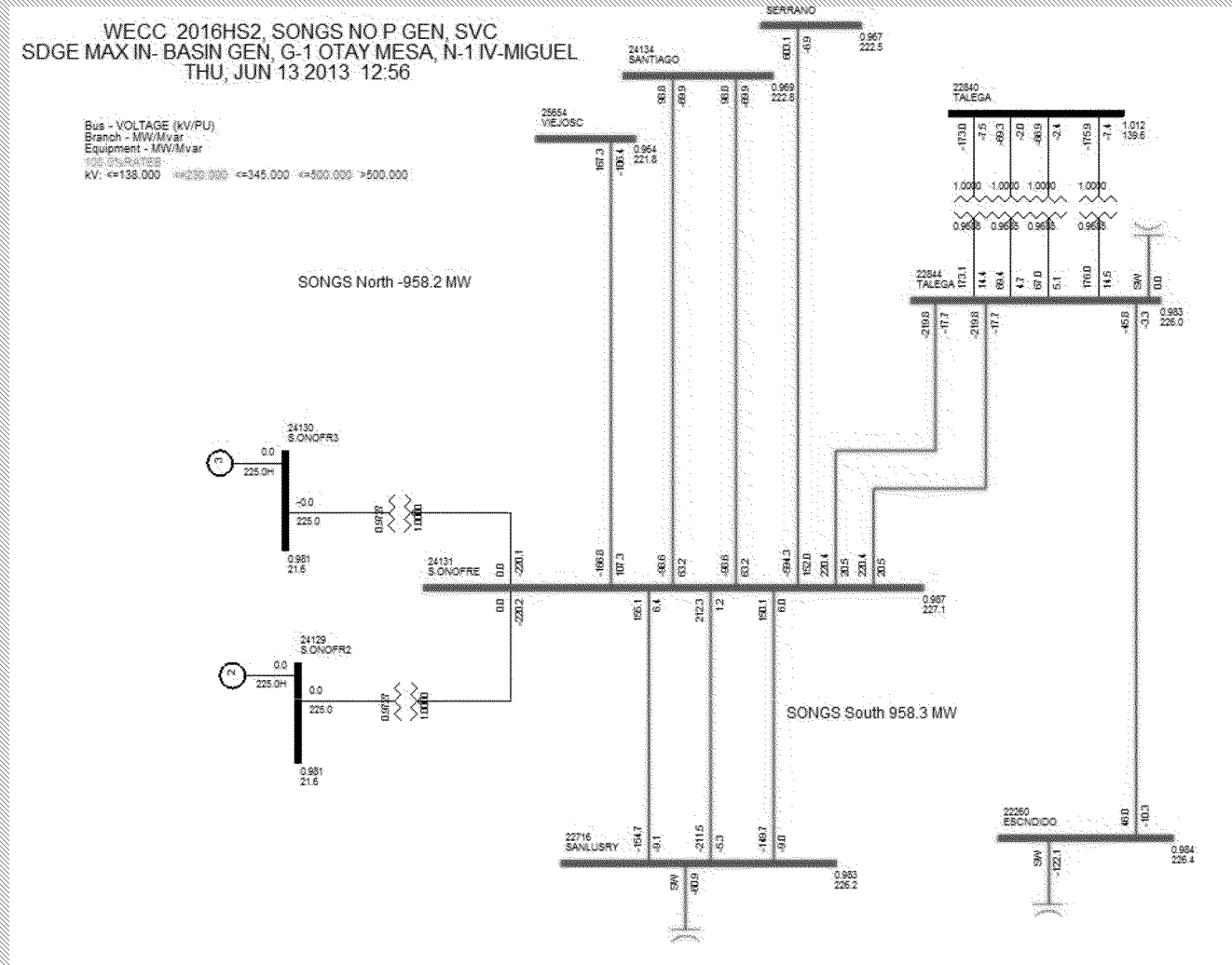

Nevada Hydro Company

San Diego High Gen, G-1, N1 Otay Mesa Area

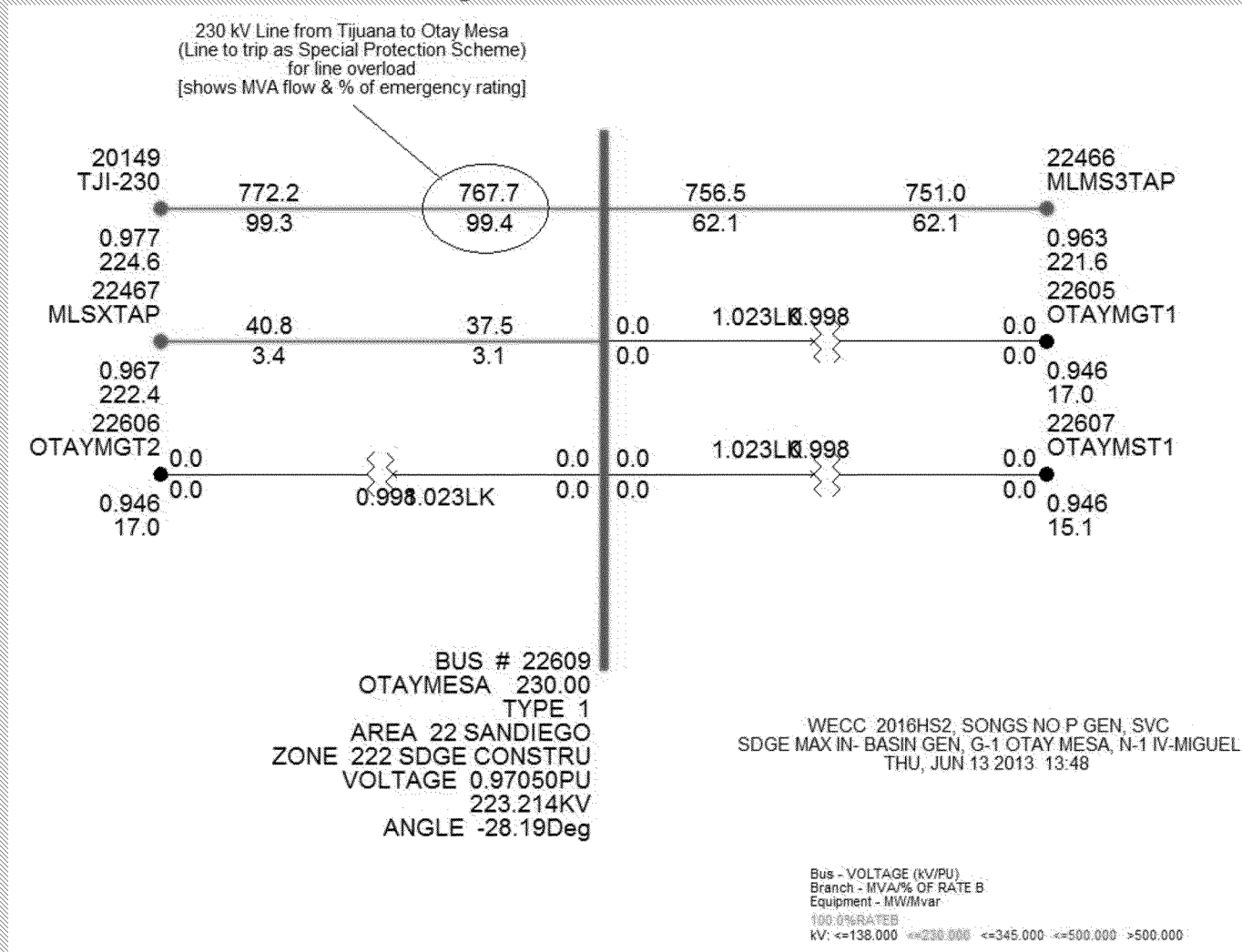

Nevada Hydro Company

Conclusion

- Base Plan without TE/VS
- Category C (N-1-1) contingency - loss of Imperial Valley-Miguel 500 kV line and then loss of the Sunrise 500 kV line:
 - even with all possible generation in the area south of Serrano all the way to the Mexican border at full output,
 - **full blackout of the LA Basin and the San Diego area.**
- G-1, N-1 Just Survives if all San Diego Gen at Max.
- Additional transmission needed to assure reliability.

Addition of TE/VS-LEAPS

Modeling Assumptions

- 2016 modeling data, without SONGS
- Cases with LEAPS and TE/VS added to Base Case
 - N-1-1 loss of IV-Miguel and Sunrise

LEAPS-TE/VIS, San Diego High Gen, N-1-1 SONGS Area

Bus - VOLTAGE (kV/PU)
 Branch - MW/Mvar
 Equipment - MW/Mvar
 100.0% RATED
 KV: <=30.000 <=330.000 <=345.000 <=500.000 >500.000

WECC 2016HS2 SONGS NO P GEN, SVC, LEAPS AND TEVS ADDED
 SDGE MAX IN-BASIN GEN, N-1-1 IV-MIGUEL, SUNRISE
 THU, JUN 13 2013 14:41

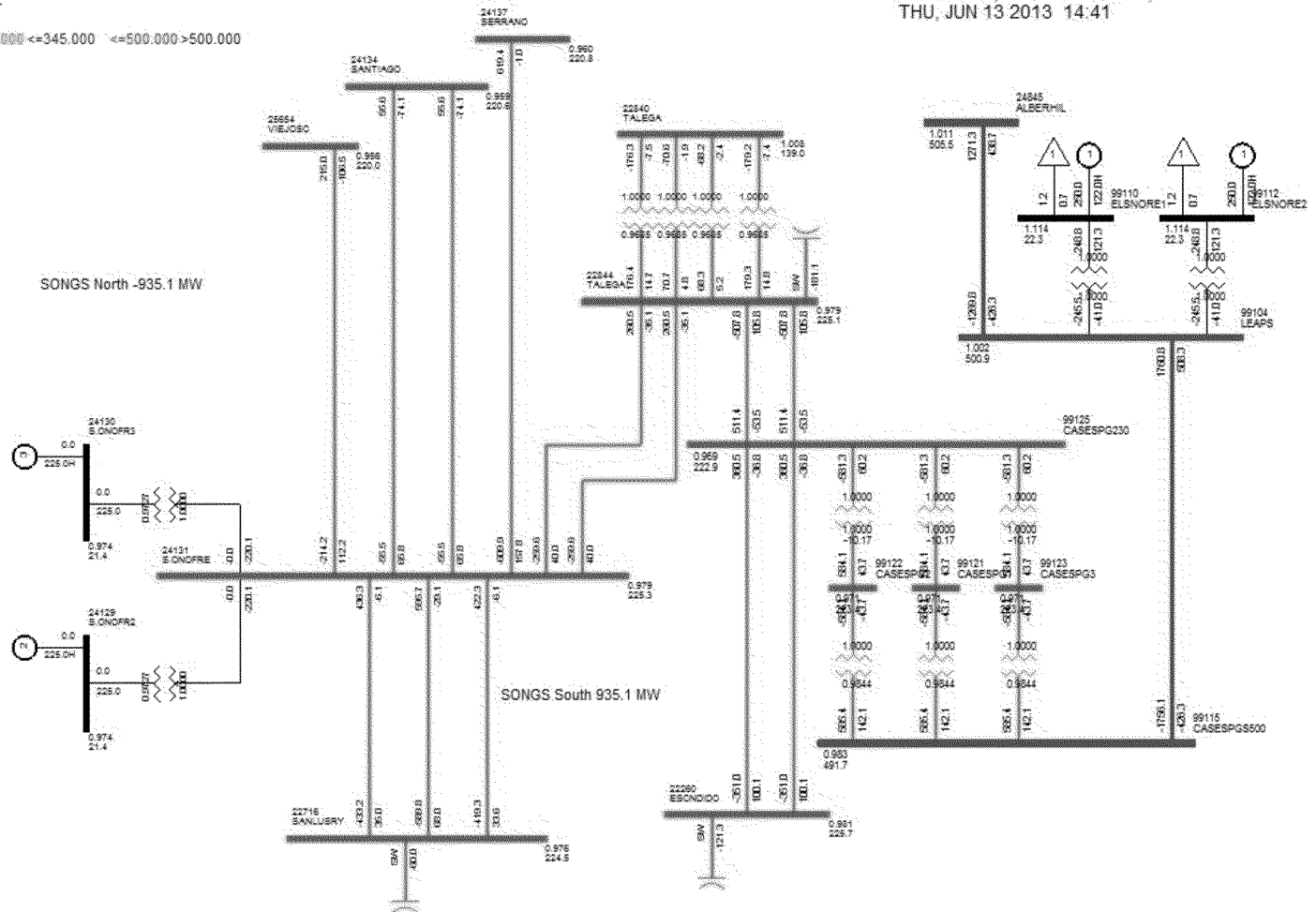

Nevada Hydro Company

LEAPS-TE/VIS San Diego High Gen, N-1-1 IV Area

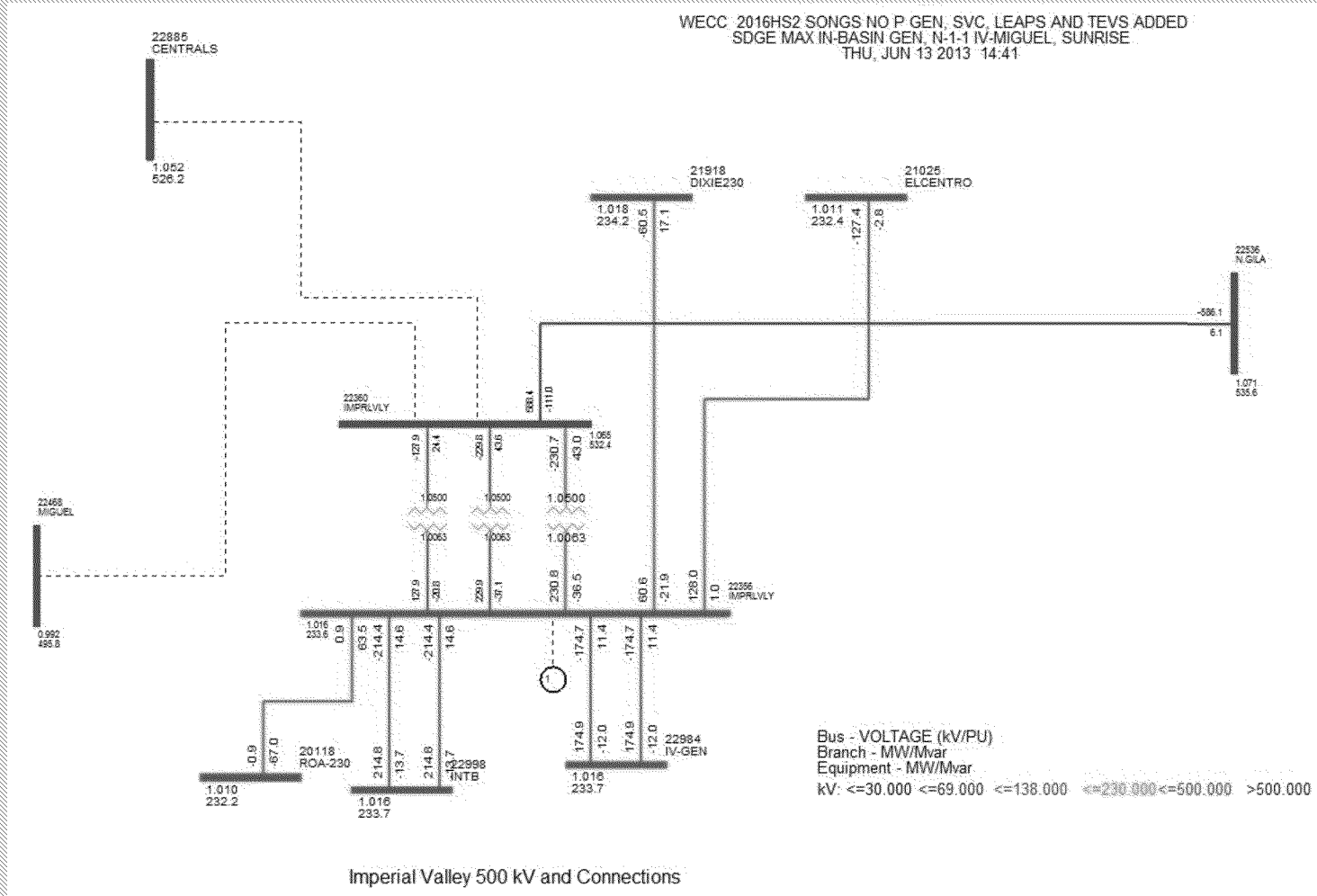

Nevada Hydro Company

LEAPS-TE/VS, San Diego High Gen, N-1-1 Serrano Area

WECC 2016HS2 SONGS NO P GEN, SVC, LEAPS AND TEVS ADDED
SDGE MAX IN-BASIN GEN, N-1-1 IV-MIGUEL, SUNRISE
THU, JUN 13 2013 14:44

Bus - VOLTAGE (kV/PU)
Branch - MW/Mvar
Equipment - MW/Mvar
KV: <=30.000 <=230.000 <=345.000 <=500.000 >500.000

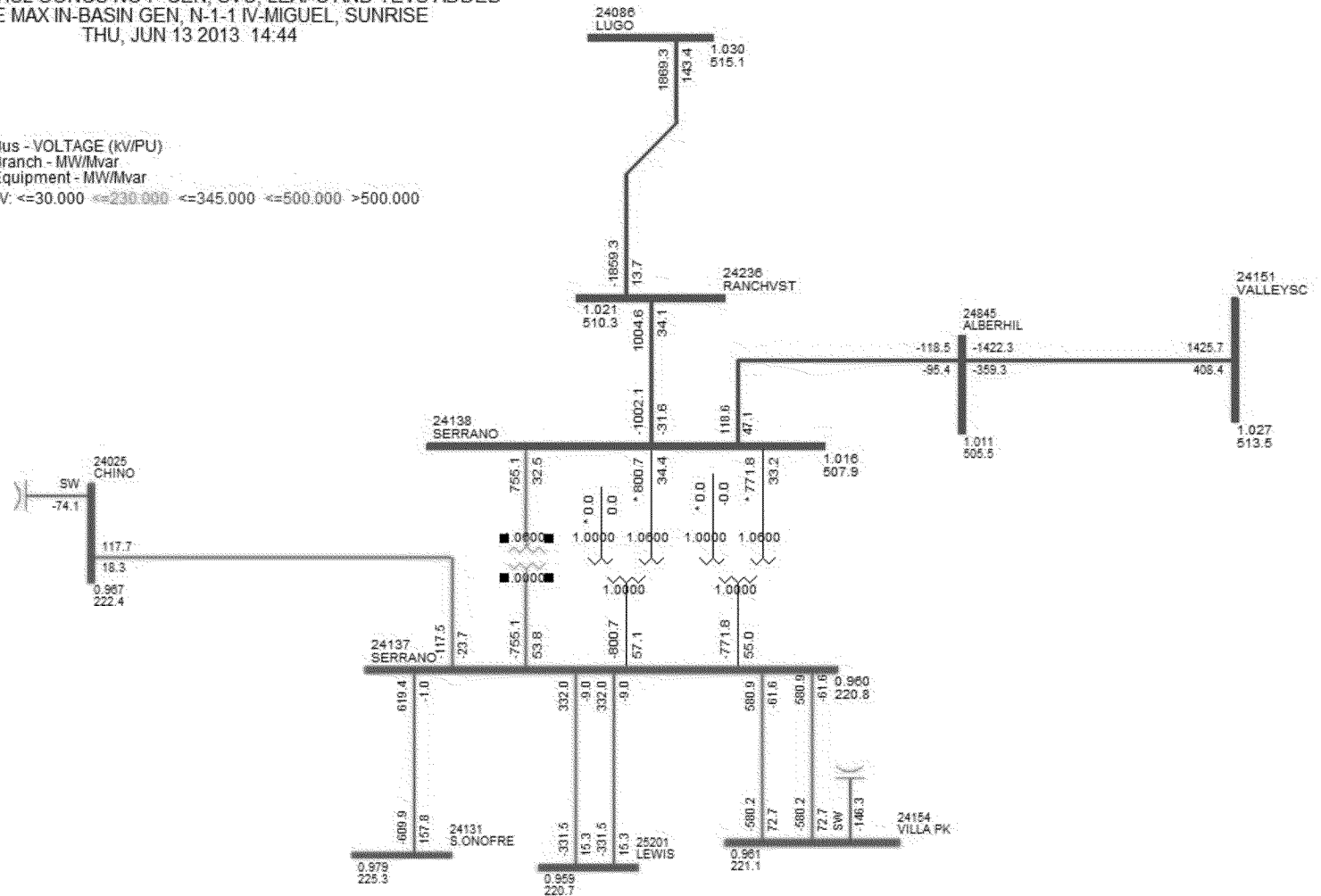

Nevada Hydro Company

30

LEAPS-TE/VIS San Diego High Gen, N-1-1 Otay Mesa Area

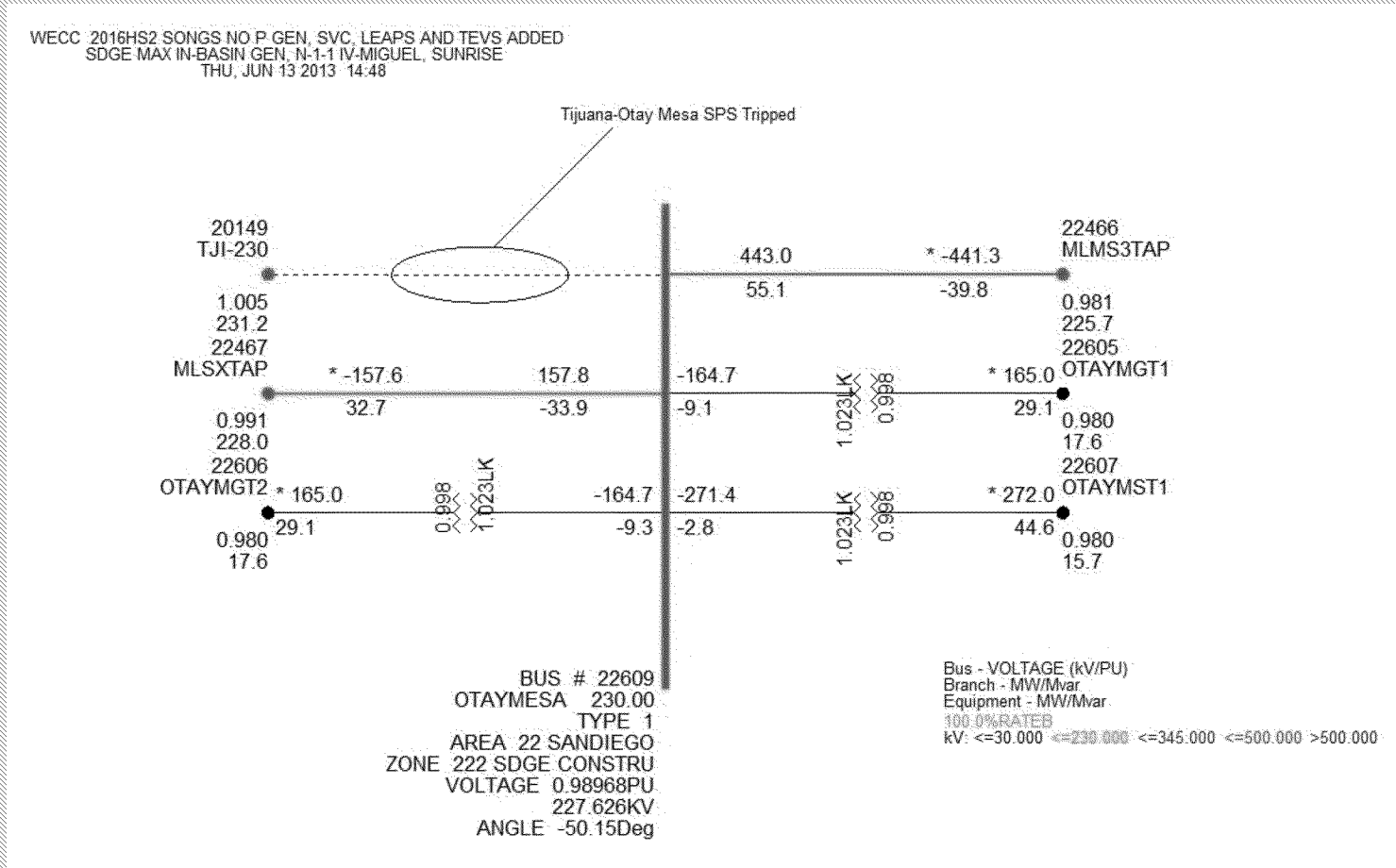

Conclusion

- Plan with TE/VS
- Category C (N-1-1) contingency - loss of Imperial Valley-Miguel 500 kV line and then loss of the Sunrise 500 kV line:
 - **Provides survival of retirement of SONGS**

Talega Extension

Modeling Assumptions

- 2016 modeling data, without SONGS
- Cases with LEAPS and TE/VS added to Base Case
- 500 kV line added from Case Springs to Talega to TEVS-LEAPS plan,
 - High generation in San Diego basin, no contingency
 - High generation in San Diego basin, N-1-1
- TEVS added to base case, 500 kV line from Case Springs to Talega
 - High generation in San Diego basin, no contingency
 - High generation in San Diego basin, N-1-1

Base Case: TE/VIS-LEAPS (with Talega Extension)

SONGS Area

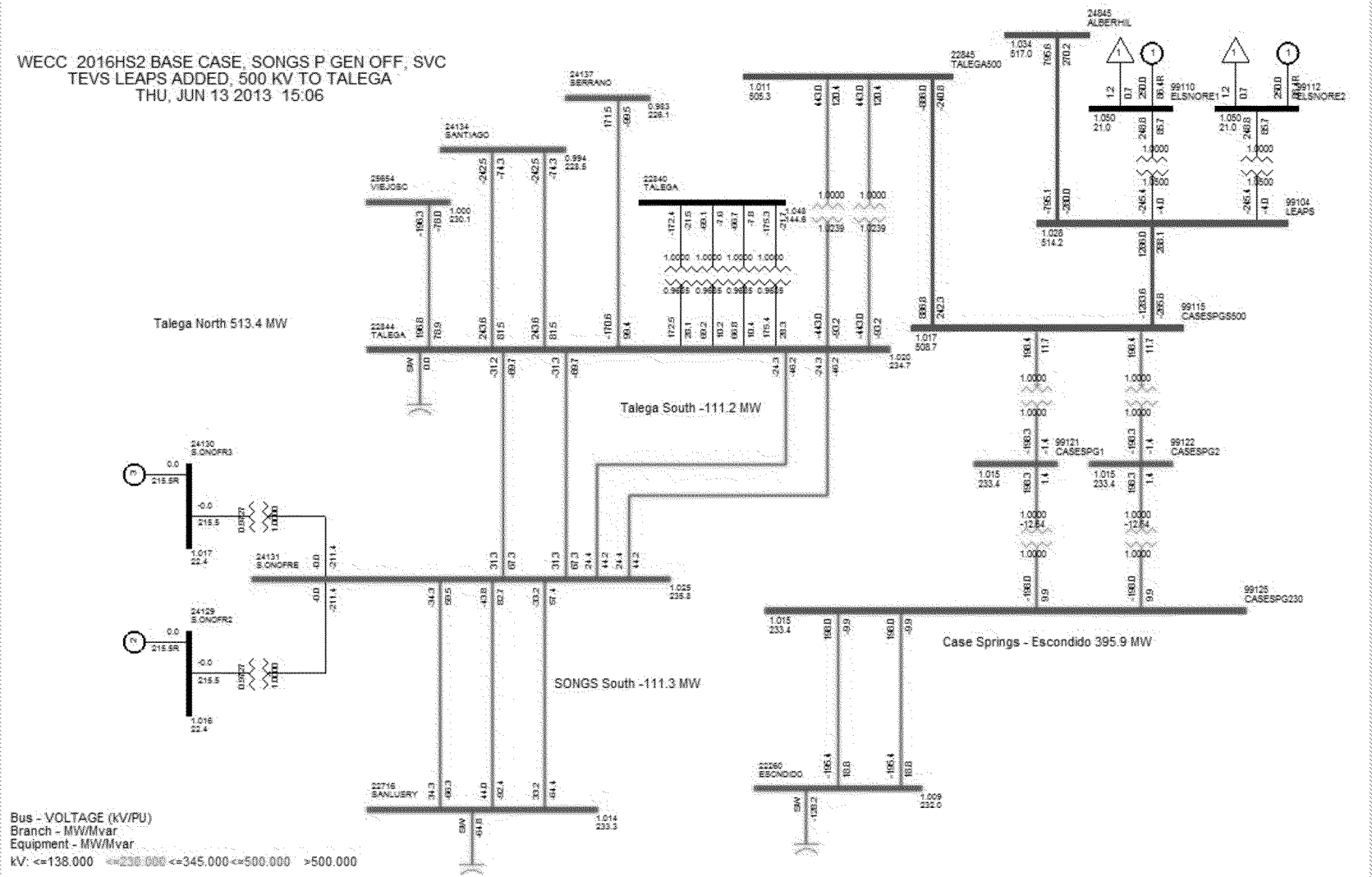

Nevada Hydro Company

Base Case: TE/VS-LEAPS with Talega 500 kV Serrano Area

WECC 2016HS2 BASE CASE, SONGS P GEN OFF, SVC
TEVS LEAPS ADDED, 500 KV TO TALEGA
THU, JUN 13 2013 15:10

Bus - VOLTAGE (kV/PU)

Branch - MW/Mvar

Equipment - MW/Mvar

KV: <=30.000 <=230.000 <=345.000 <=500.000 >500.000

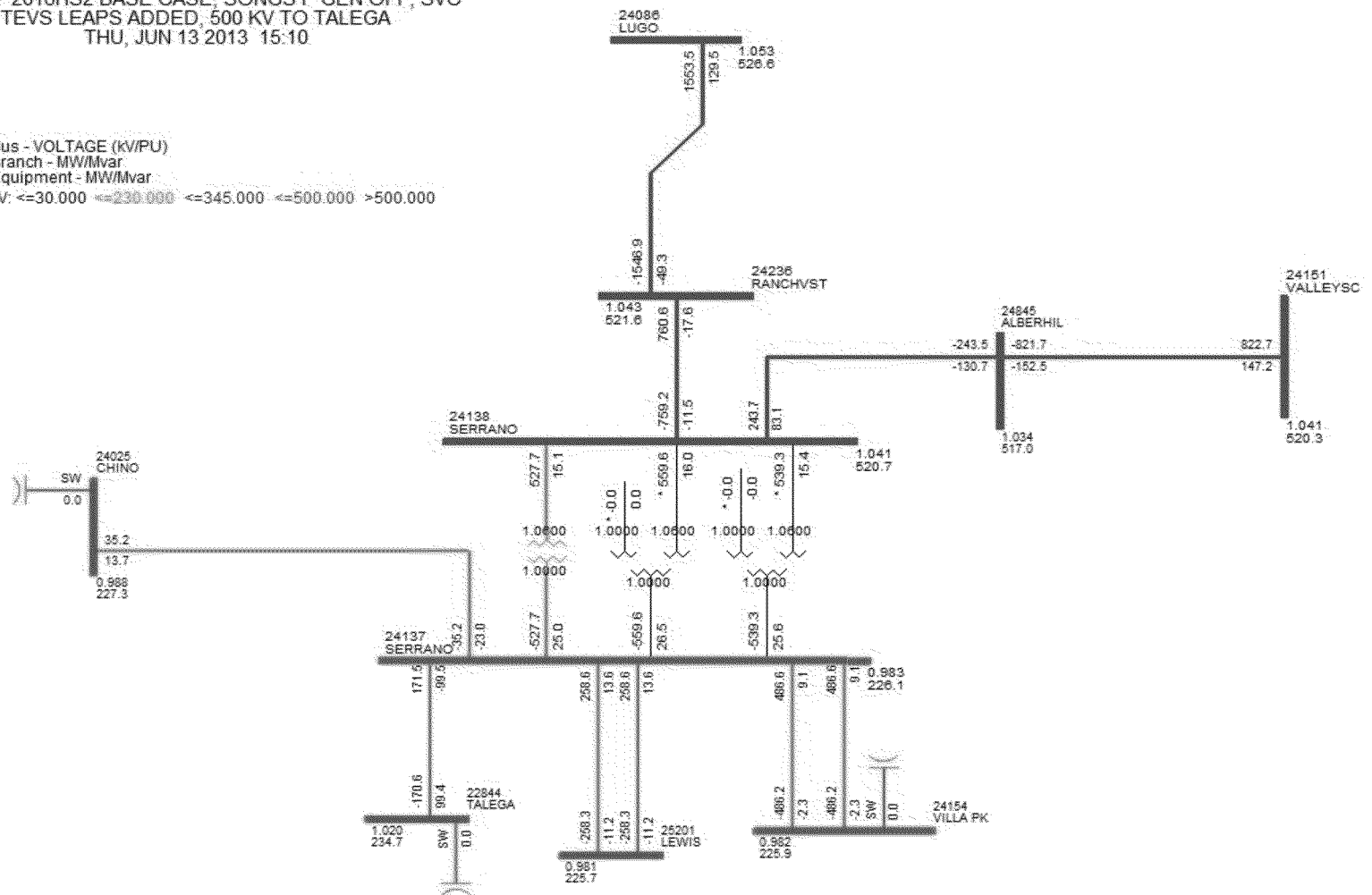

Nevada Hydro Company

35

Base Case: TE/VIS-LEAPS(with Talega Extension) IV Area

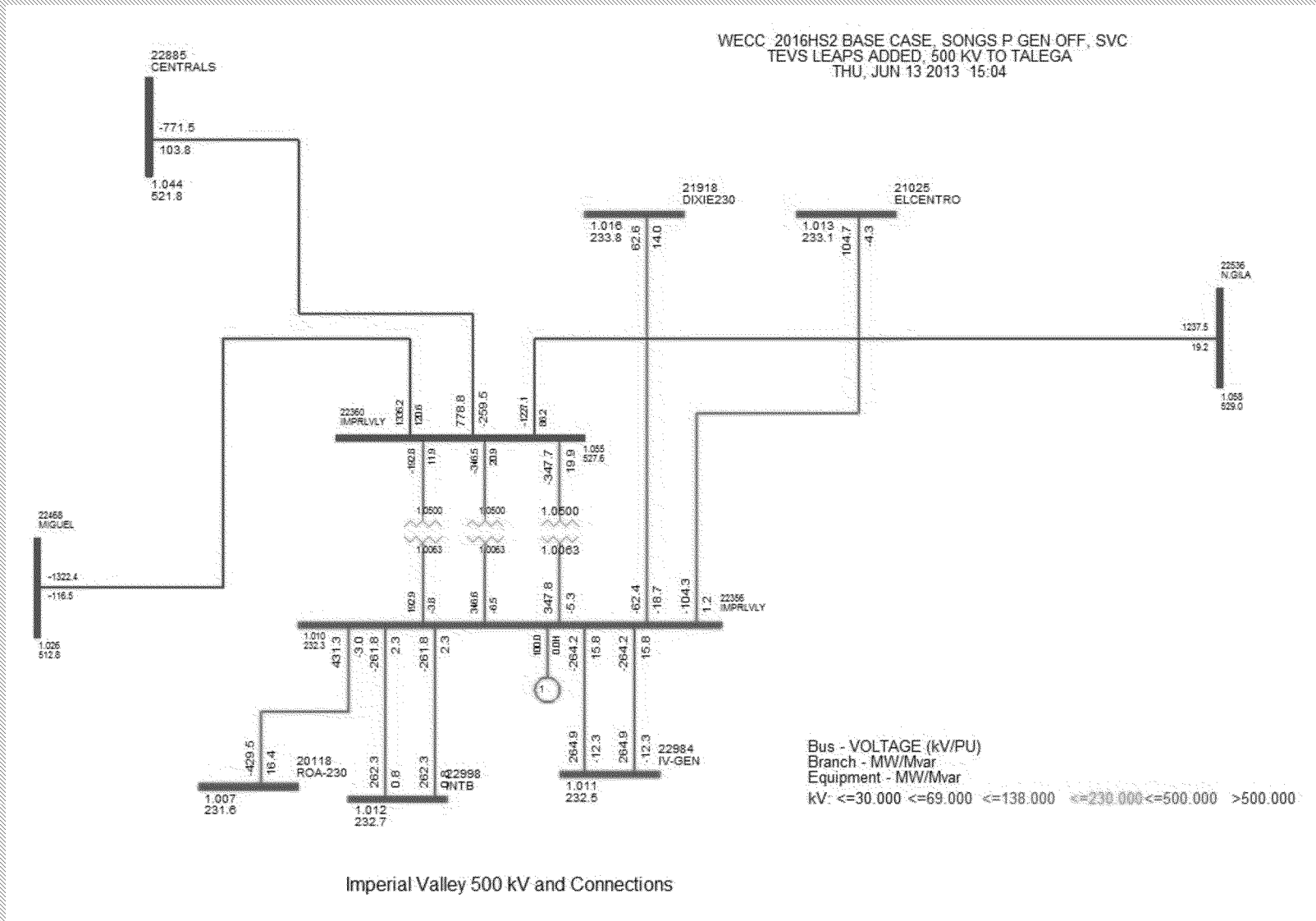

Nevada Hydro Company

Base Case: TE/VIS LEAPS with Talega 500 kV Otay Mesa Area

WECC 2016HS2 BASE CASE, SONGS P GEN OFF, SVC
TEVS LEAPS ADDED, 500 KV TO TALEGA
THU, JUN 13 2013 15:05

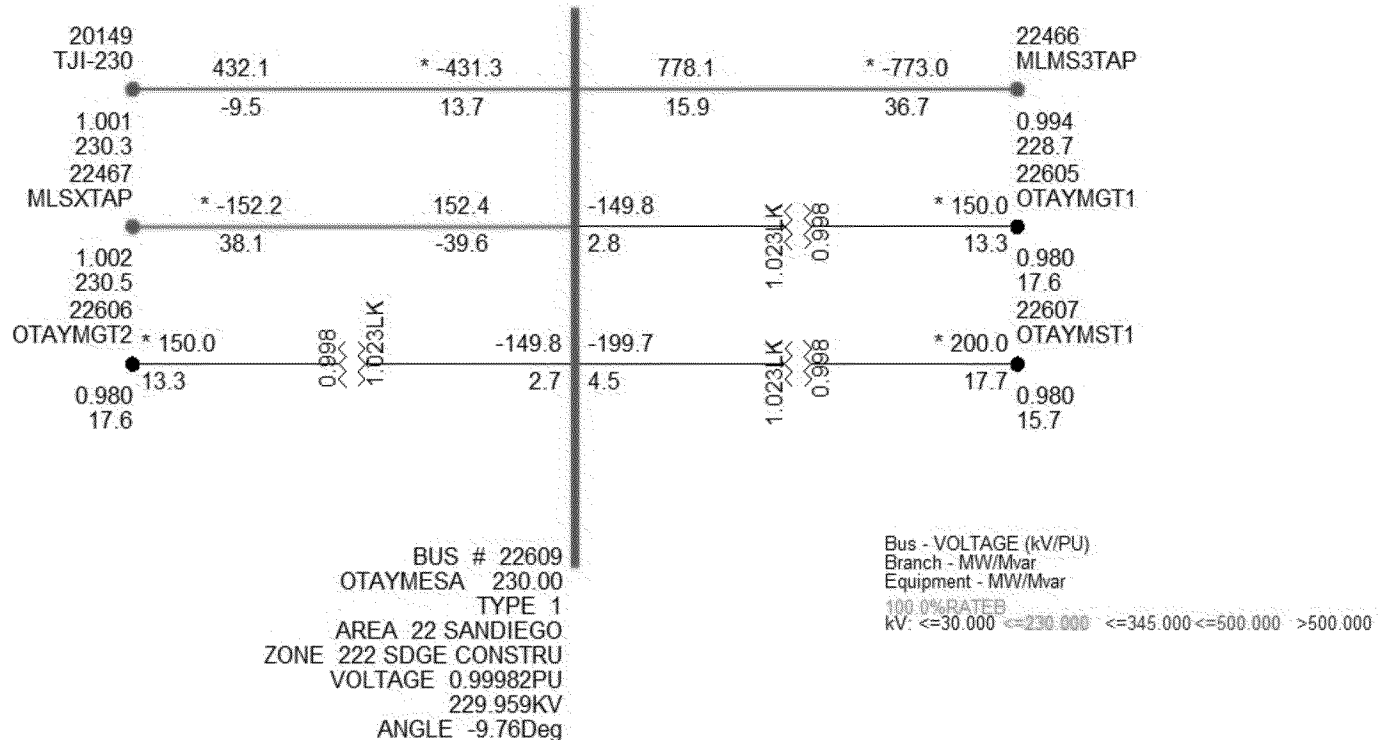

Nevada Hydro Company

37

LEAPS-TE/VIS, San Diego High Gen, N-1-1 IV Area

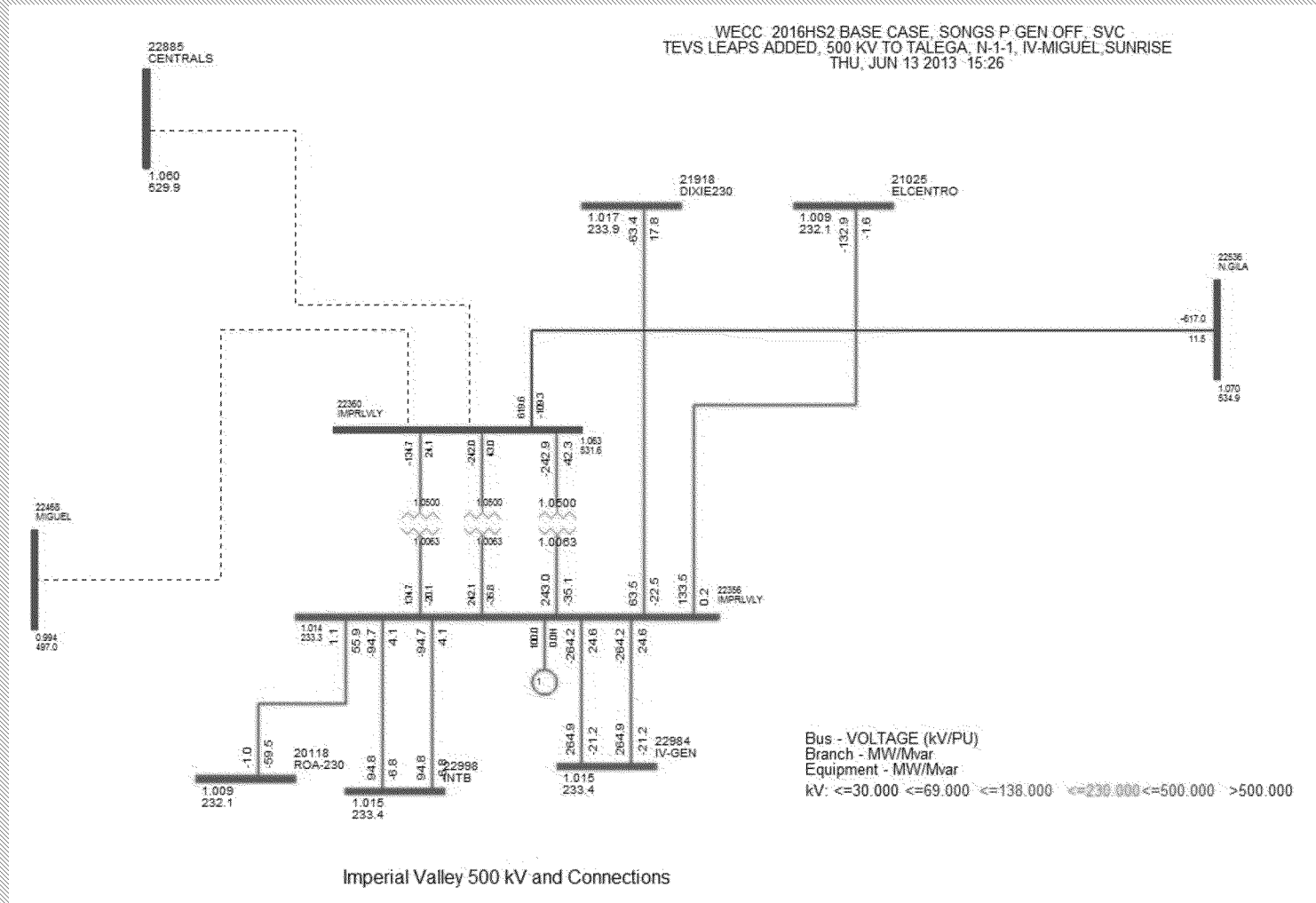

Nevada Hydro Company

LEAPS-TE/VIS, San Diego High Gen, N-1-1 Otay Mesa Area

WECC 2016HS2 BASE CASE, SONGS P GEN OFF, SVC
TEVS LEAPS ADDED, 500 KV TO TALEGA, N-1-1, IV-MIGUEL, SUNRISE
THU, JUN 13 2013 15:26

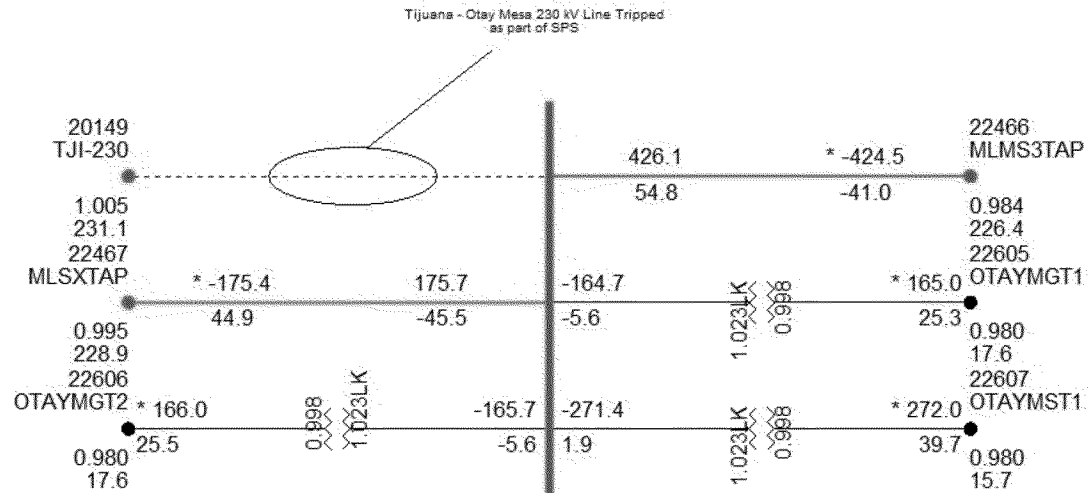

BUS # 22609
OTAYMESA 230.00
TYPE 1
AREA 22 SANDIEGO
ZONE 222 SDGE CONSTRU
VOLTAGE 0.99233PU
228.236KV
ANGLE -49.33Deg

Bus - VOLTAGE (kV/PU)
Branch - MW/Mvar
Equipment - MW/Mvar
100.0% RATED
kV: <=30.000 <=230.000 <=345.000 <=500.000 >500.000

LEAPS-TE/VS, San Diego High Gen, n-1-1 Serrano Area

WECC 2016HS2 BASE CASE, SONGS P GEN OFF, SVC
TEVS LEAPS ADDED, 500 KV TO TALEGA, N-1-1, IV-MIGUEL, SUNRISE
THU, JUN 13 2013 15:27

Bus - VOLTAGE (KV/PU)
Branch - MW/Mvar
Equipment - MW/Mvar
KV: <=30.000 <=230.000 <=345.000 <=500.000 >500.000

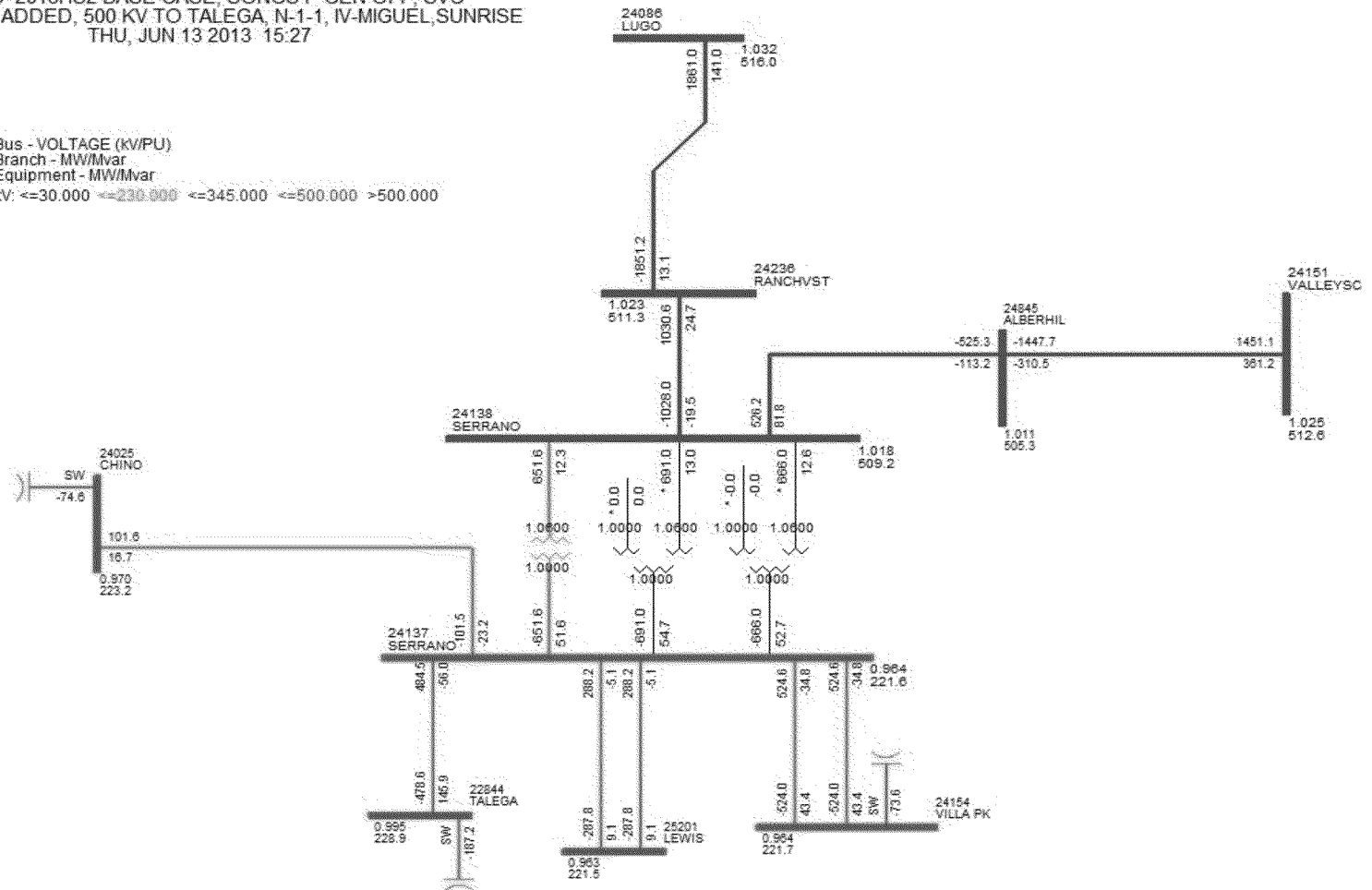

Nevada Hydro Company

40

LEAPS-TE/VS, San Diego High Gen, N-1-1 Songs Area

WECC 2016HS2 BASE CASE, SONGS P GEN OFF, SVC
TEVS LEAPS ADDED, 500 KV TO TALEGA, N-1-1, IV-MIGUEL, SUNRISE
THU, JUN 13 2013 15:26

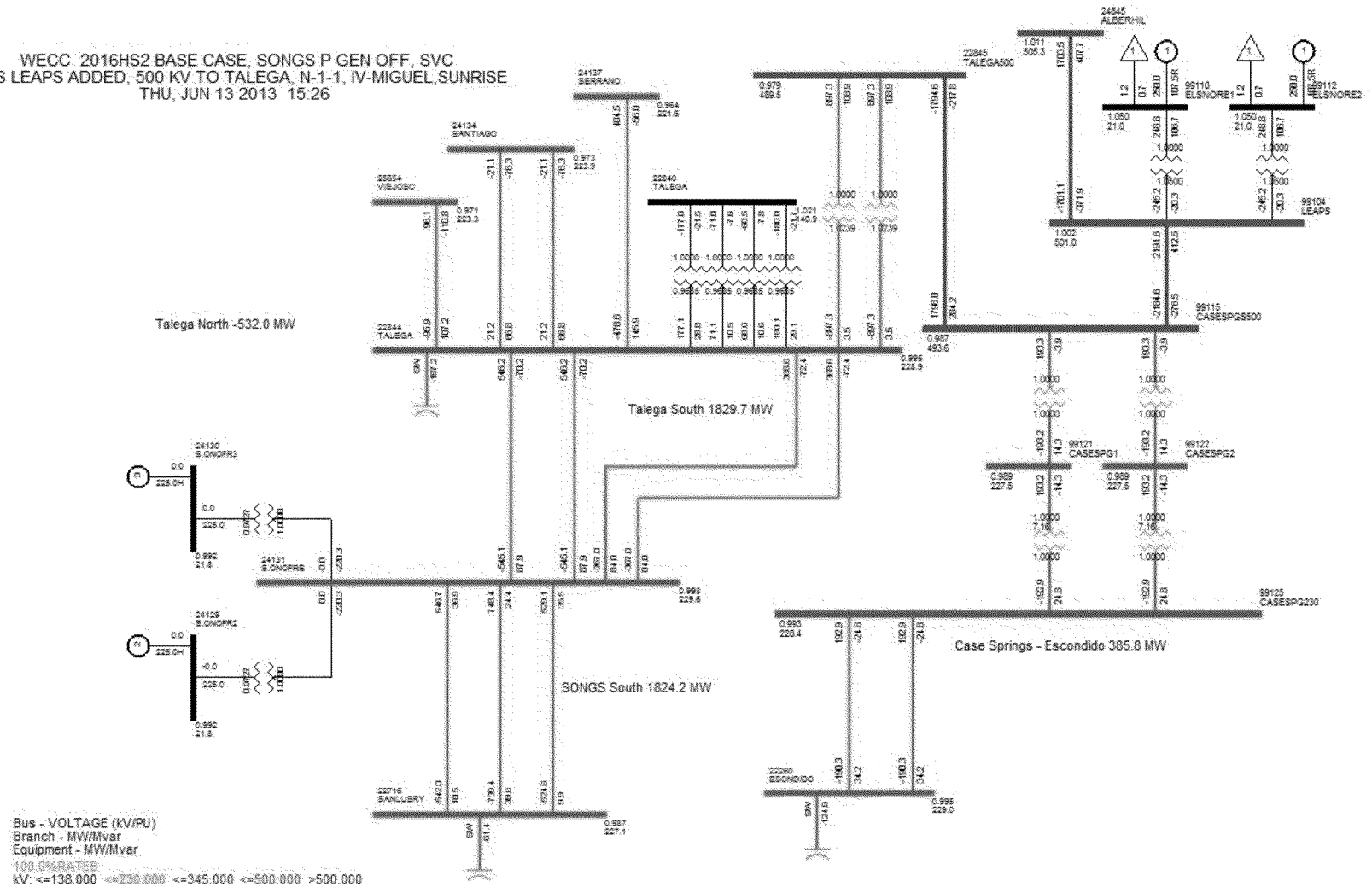

Nevada Hydro Company

Conclusions

- TE/VS-LEAPS with Talega Extension provides additional margin of deliverability
- Category C (N-1-1) contingency - loss of Imperial Valley-Miguel 500 kV line and then loss of the Sunrise 500 kV line:
 - More easily provides reliable service to region
 - **Provides capability to improve both retirement of SONGS and OTC retirements**

Conclusions

1. TE/VS-LEAPS provides near-term reliability needs for retirement of SONGS.
2. TE/VS-LEAPS with 500 kV extension to Talega provides additional capability to assure reliability with SONGS and Once-through-Cooling Generation retirement.
3. TE/VS-LEAPS is “Shovel ready” pending CPUC approval.