

Assembly instruction

Zinc oxide surge arresters

HS PEXLIM P-T and HS PEXLIM T-T

Power and productivity
for a better world™





SB_GT&S_0443234

1. Introduction

Safety information

Key to the signs

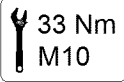
	This sign is a visual notice to avoid mistakes which can result in damage of the material and/or no function of the surge arrester. Read the text carefully and if you don't understand do not proceed.
	Serious material damage, severe personal injury and/or death can be the result of not following the information given at this sign. Read the text carefully and if you don't understand do not proceed.
	The bolt of the given size shall be tightened with a torque wrench to the specified value.

Important information

The following instruction is valid for HS PEXLIM P-T and HS PEXLIM T-T surge arresters for vertical, upright mounting including non-catalogue arresters with the following additional suffix letters:



E = Non -standard electrical data

Serious material damage, severe personal injury and/or death can be the result of not following this instruction. Therefore, the personnel responsible for the installation of the equipment shall read and follow the instruction carefully.

Handling and maintenance of all the surge arresters described in this instruction must be done by personnel trained for this type of work.



WARNING!

All work related to the surge arresters shall be made with disconnected and earthed conductors. Follow all regulations and rules stated by international and national safety regulations.

Normally, surge arresters operate at a high voltage. Therefore, they must be installed in such a way that only qualified personnel has access to them.

Storage

In all cases and with consideration to specific local conditions, appropriate steps must be taken to ensure the equipment and packaging is stored in such a way as to protect it from damage or deterioration.

Introduction

Table of contents

Section	Subject	Page
1. Introduction		
1.1	Sequence of assembly	4
1.2	Inspection upon arrival	4
2. Lifting		
2.1	Lifting the surge arrester	5
2.2	Lifting the surge arrester during assembly	6
3. Line terminals		
3.1	Fit the line terminal	7
4. Grading ring		
4.1	Grading ring arrangement	8
4.2	Grading ring assembly	9
4.3	Grading ring with drainage holes	10
5. Relative position of arrester units		
5.1	Rating plate	11
5.2	Single-unit arrester	12
5.3	Two-unit arrester	13
5.4	Three-unit arrester	14
6. Assembly of units and grading rings		
6.1	Assembly of units and grading rings	15
7. Installation on structure		
7.1	Installation on structure without insulating base	16
7.2	Installation on structure with insulating base	17
8. Connection of conductors		
8.1	Mechanical load of the surge arrester	18
8.2	Connection of the conductor	19
8.3	Connection of the conductor to the line terminal	20
8.4	Connection of the conductor to the earth terminal	21
8.5	Installation of surge counter or EXCOUNT-II	22
9. Maintenance		
9.1	Maintenance and checking	23
10. Disposal		
10.1	Disposal of the surge arrester	24

Introduction

1.1 Sequence of assembly

The procedure outlined here should be followed for safe and correct installation of the surge arresters.

Order	Procedure	Details in section
1	Inspection upon arrival.	below
2	Lift the arrester units from the crate.	2
3	Fit the line terminal on the top cover.	3
4	Assembly the grading rings for the top unit.	4
5	Fit the top unit grading rings and top cover on the top unit.	6
6	Lift the top unit and assemble it with the second unit. Repeat the procedure until the arrester is completely assembled on the ground.	6
7	Fit the insulation base under the bottom unit if any along with the earth terminal or diagnostic indicator EXCOUNT-II when provided.	7
8	Lift the arrester and secure it on the structure.	2 and 7
9	Connect the earth and line conductors.	8

Multi-unit arresters must be erected with their units in correct order, see section 5 on page 11.



The instruction must be followed in correct order to prevent problems during assembly. In the case where an arrester is not supplied with an insulating base and/or surge counter, the paragraphs dealing with these accessories may be disregarded.

1.2 Inspection upon arrival

Upon arrival it is important that the cases are inspected and the contents checked against the packing list which is attached to each case. Any shortage or damage should be reported immediately to the insurance and/or ABB representative within 30 days from the arrival of goods at site. ABB cannot take responsibility for shortage or damages not reported within this time period.

If the contents are to be stored for a long period of time prior to installation they must be repacked and stored, preferably dry and indoors. However, outdoor storage is acceptable.

2. Lifting

2.1 Lifting the surge arrester

It is very important to place the lifting slings around the metal flange and not around the flange neck covered with silicone rubber. See figure 2.2. Arrange the lifting slings according to figure 2.1. NOTE, it's important to use two lifting slings at each flange.

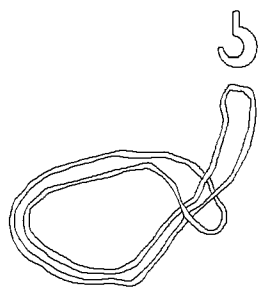
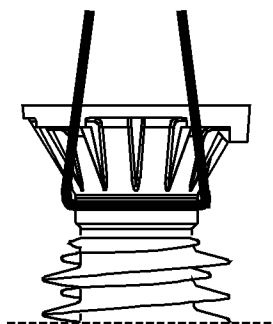

Fig 2.1
Sling arrangement (2x)

Lifting vertical

Correct placement of lifting slings



WARNING!
Faulty placement of lifting slings

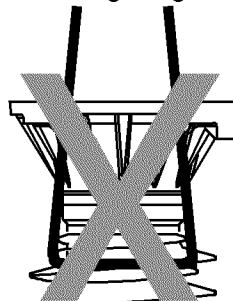

Fig 2.2
Placement of lifting slings



Be careful so that the arrester units do not hit anything during lifting!

Keep the lifting slings in place until the completely assembled arrester is securely anchored to the structure.

NOTICE! Do not place the lifting slings upon the part of the flange neck that is covered with silicone rubber, see figure 2.2.

Lifting

2.2 Lifting the surge arrester during assembly

When lifting surge arrester unit or complete assembled surge arrester, two lifting slings must be used. Place the slings around the upper metal flange of the insulator. See figure 2.3 and 2.4. See also figure 2.2 for correct placement of lifting slings.

Table 2.1

Typical weight of the smallest to the largest surge arrester.	HS PEXLIM P-T	HS PEXLIM T-T
		115 to 365 kg

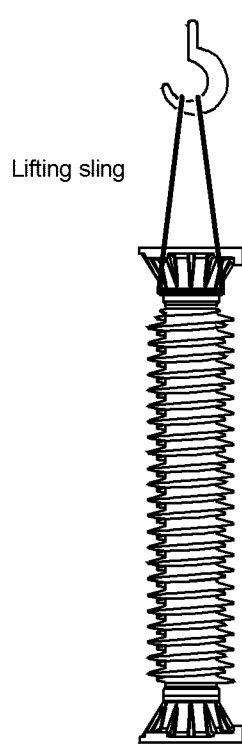

Fig 2.3
Lifting a surge arrester unit

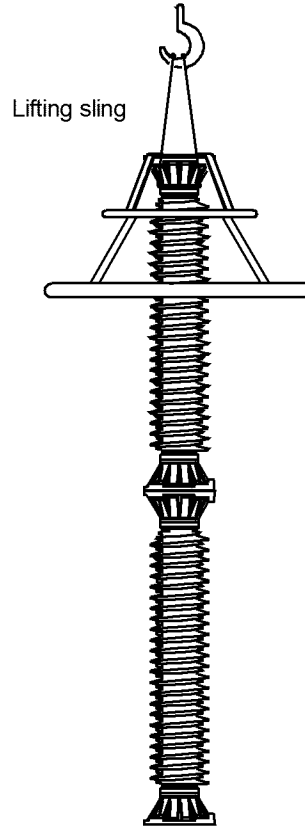

Fig 2.4
Lifting of the complete assembled surge arrester onto the structure

3. Line terminal

3.1 Fit the line terminal

Fit the line terminal to the top cover according to figure 3.1 - 3.2. Recommended tightening torque is 270 Nm (M20).

Line terminal with clamp:

When the line conductor is to be connected, put together the clamp according to section 8 on page 19.

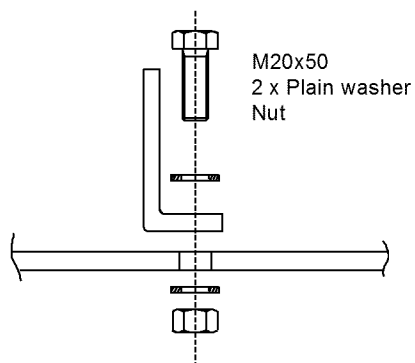

Fig 3.1
Assembly of
1HSA410 000-A, -B, -F, -G, -H, -J -K

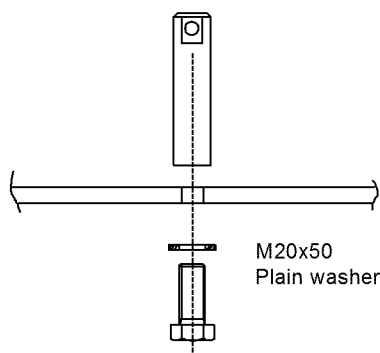

Fig. 3.2
Assembly of
1HSA410 000-C, -D, -E

4. Grading ring

4.1 Grading ring arrangement



When a grading ring is supplied, it must be fitted to the arrester. Otherwise the correct performance is not guaranteed. If the surge arrester has a grading ring, assemble the stays with the ring/rings according to the table 4.1.1 and the figures on next page. The recommended tightening torque for M10 screws is 33 Nm.

Table 4.1.1 Grading ring arrangement. The letters in the table refer to the figures on next page.

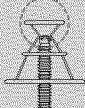
Type designation	 See 4.2	 See 4.2
HS PEXLIM P-T		
P180-TM245 — P192-TM245	A	
P180-TH245 — P228-TH245	A	
P228-TM300 — P264-TM300	A	
P228-TV300 — P240-TV300	B	
P264-TV300	A	
P258-TH362 — P276-TH362	B	
P288-TH300	B	
P300-TM400	B	
P330-TH420 — P390-TH420	B	
P396-TH550 — P420-TH550	B	C
P444-TH550	B	C
HS PEXLIM T-T		
T180-TH245 — T216-TH245	A	
T228-TV245	A	
T228-TV300 — T240-TV300	B	
T258-TH362 — T276-TH362	B	
T288-TH380	B	
T300-TM400	B	
T330-TH420 — T360-TH420	B	
T390-TV420	B	
T396-TH550 — T420-TH550	B	C
T444-TH550	B	C

4. Grading ring

4.2 Grading ring assembly

Assemble the grading ring according to the applicable arrester type designation in table 4.1.1. See also section 4.3 on next page for orientation of grading ring with drainage holes.

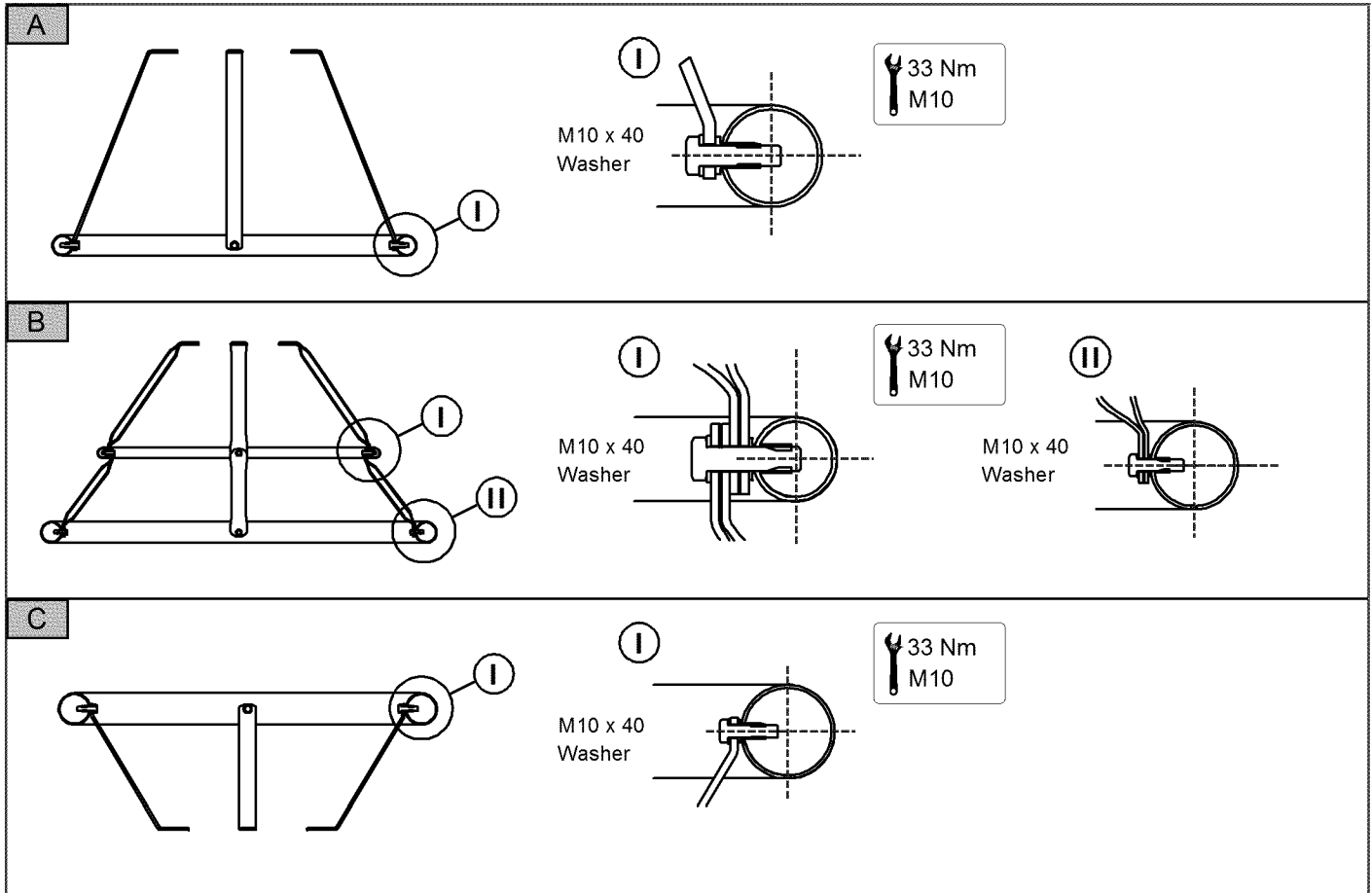

Grading ring

4.3 Grading ring with drainage holes

Assemble the grading ring with drainage holes oriented downwards, see also table 4.3.1.

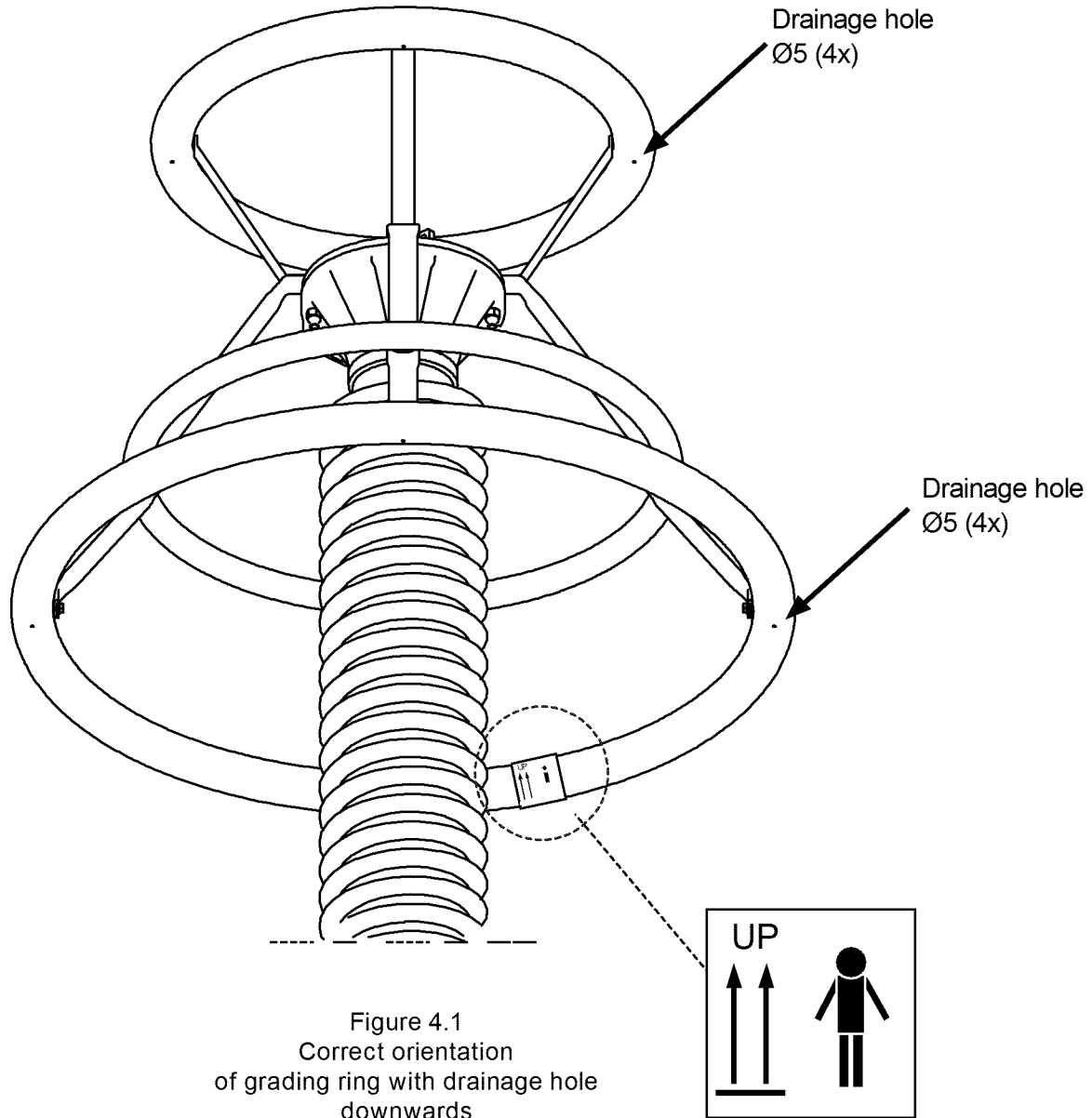

NOTE! Surge arrester with grading ring arrangement B and C:
Drainage holes must always be oriented downwards.

Table 4.3.1 The letters refer to the figures on page 9

Grading ring arrangement	View	Drainage hole	View	Drainage hole
B	I		II	x
C	I	x	II	

5. Relative position of arrester units

5.1 Rating plate



Multi-unit arresters must be erected with their units in the correct order.
All units in one arrester have the same serial number with a consecutive suffix number to identify their position, i.e. top unit = N. XXXXXXXX/1, next unit = N. XXXXXXXX/2, etc.

N. XXXXXXXX is the serial number (according to section 5.2, 5.3 and 5.4 on next pages).

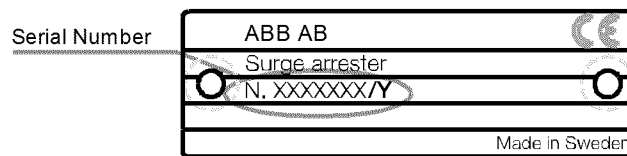

Fig. 5.1
Rating plate

Relative position of arrester units

5.2 Single-unit arrester



ABB AB		CE	
Surge arrester			
N, XXXXXXX	Year XXXX		
Class	kA	Ur	kV Uc kV
Short circuit current	kA	Made in Sweden	

HS PEXLIM P-T	HS PEXLIM T-T
Pxxx-TM245	Txxx-TH245
Pxxx-TH245	
Pxxx-TM300	

Relative position of arrester units

5.3 Two-unit arresters

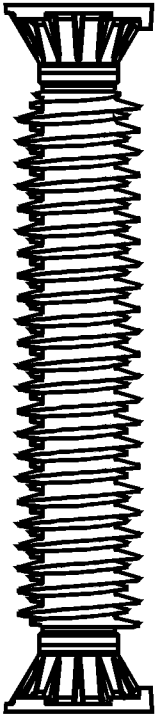
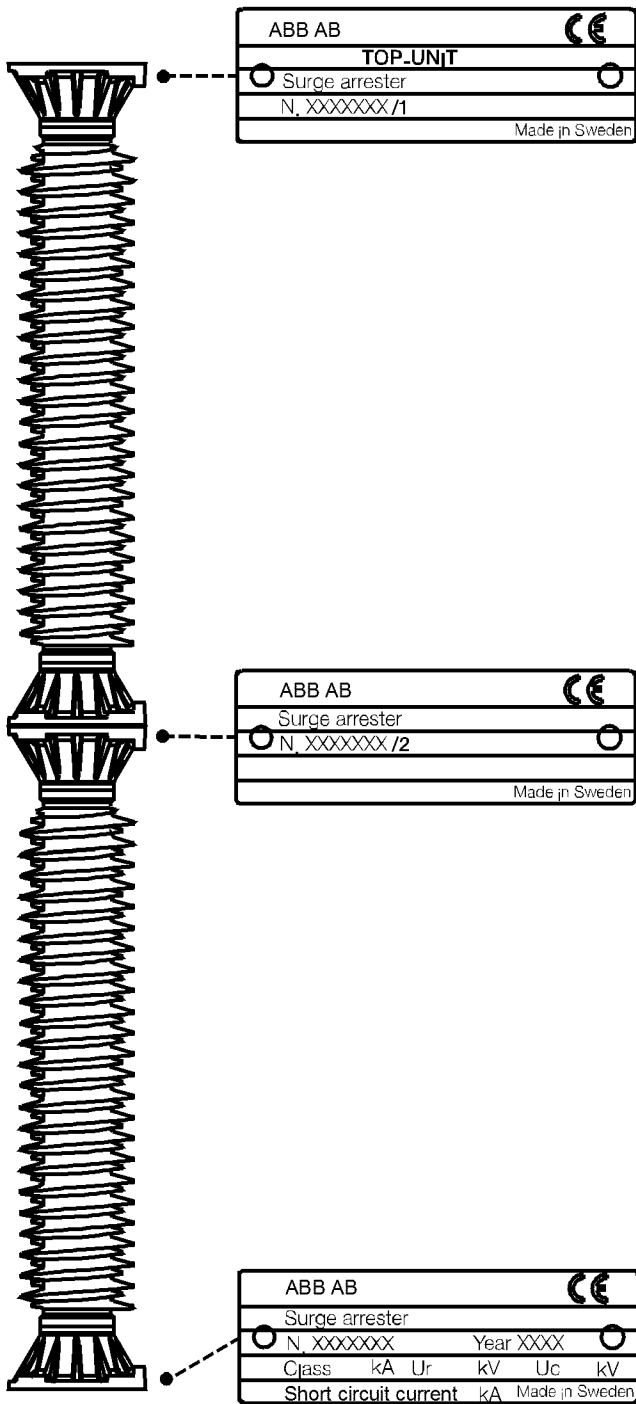

HS PEXLIM P-T	HS PEXLIM T-T
Pxxx-TV300	Txxx-TV245
Pxxx-TH362	Txxx-TV300
P288-TH380	Txxx-TH362
P300-TM400	T288-TH380
Pxxx-TH420	T300-TM400
P396-TH550	Txxx-TH420
P420-TH550	T390-TV420
	T396-TH550
	T420-TH550

Relative position of arrester units

5.4 Three-unit arresters

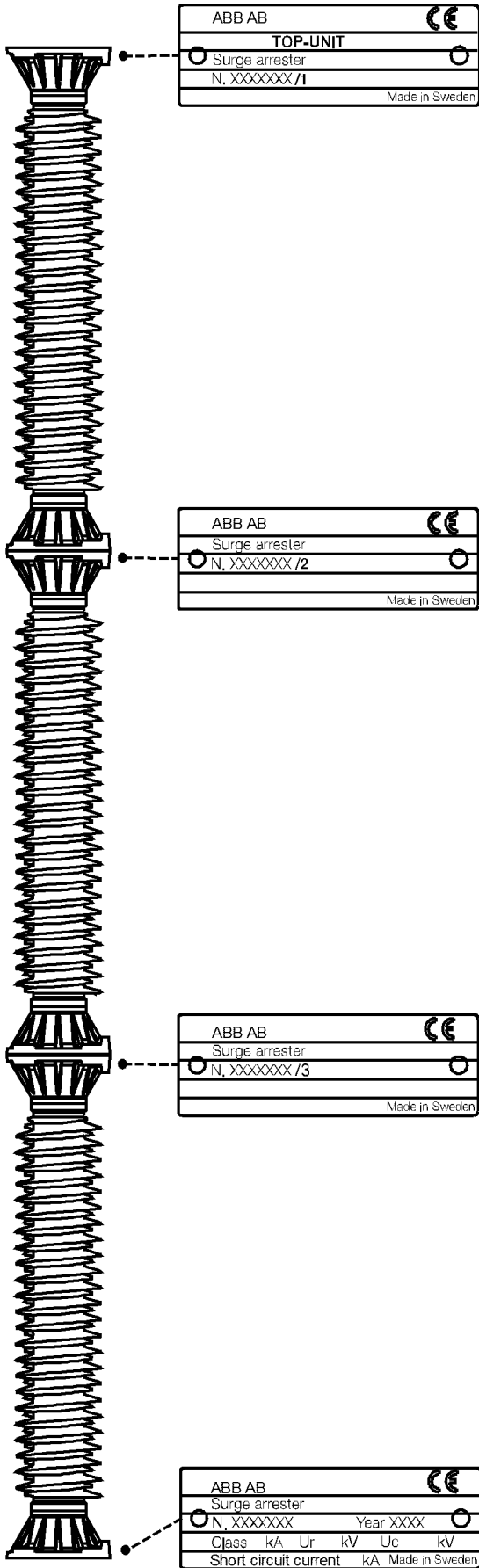

HS PEXLIM P-T	HS PEXLIM T-T
P444-TH550	T444-TH550

6. Assembly of units and grading rings

6.1 Assembly of units and grading rings

HS PEXLIM P-T and T-T

Recommended tightening torque for M16 bolts is 205 Nm

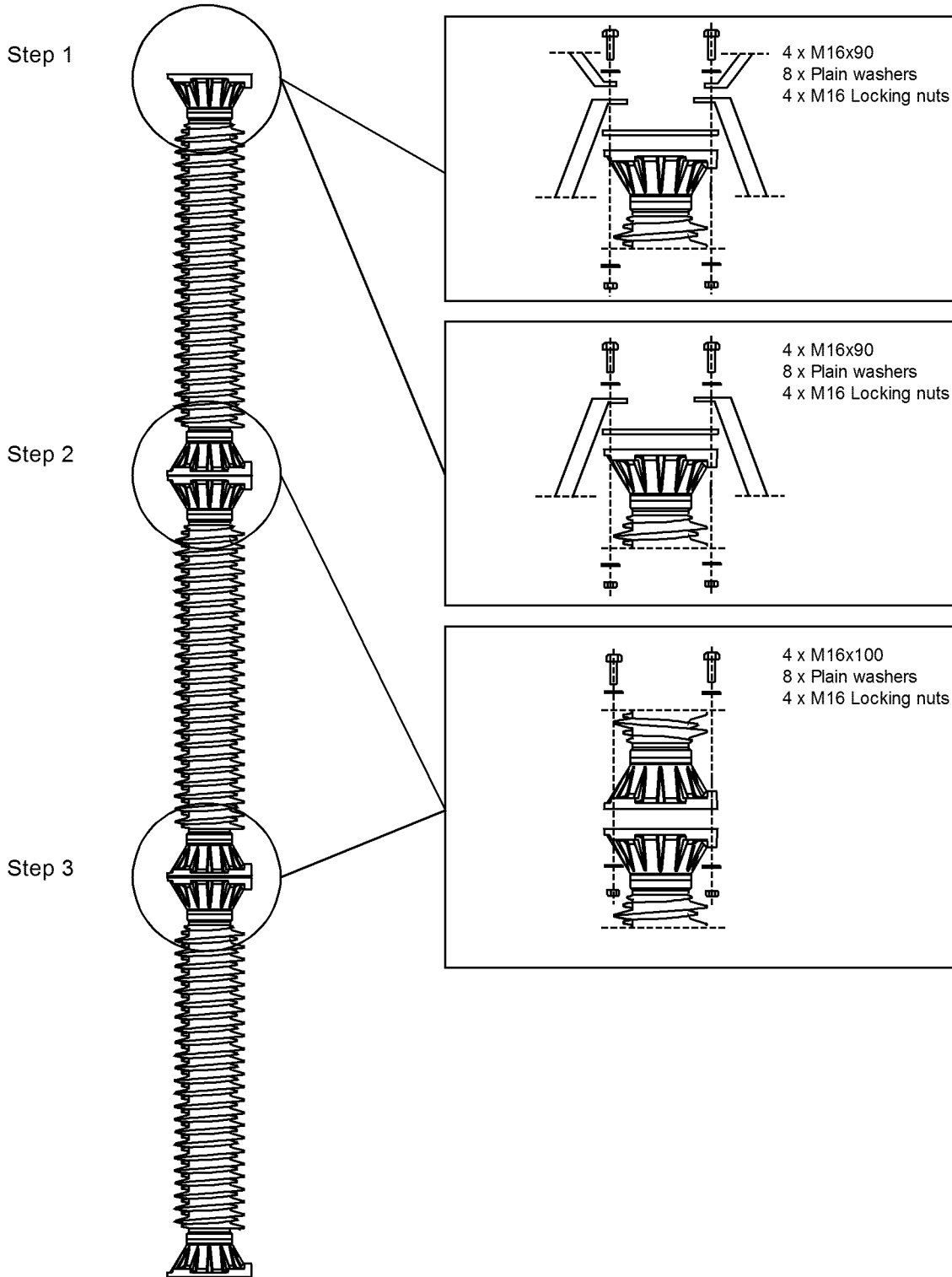
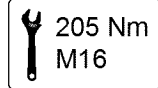

7. Installation on structure

7.1 Installation on structure without insulating base

This section covers installation of surge arrester on a structure without insulating base. For installation on a structure with insulating base see section 7.2.

Ensure that the distance between the drilling holes in the structure are according to the corresponding figure below.



Note the lifting instructions in section 2 before undertaking installation.
Anchoring bolts and nuts are not provided with the arrester.

Fit the arrester to the structure and the earth terminal to the bottom flange according to figure 7.1.2.

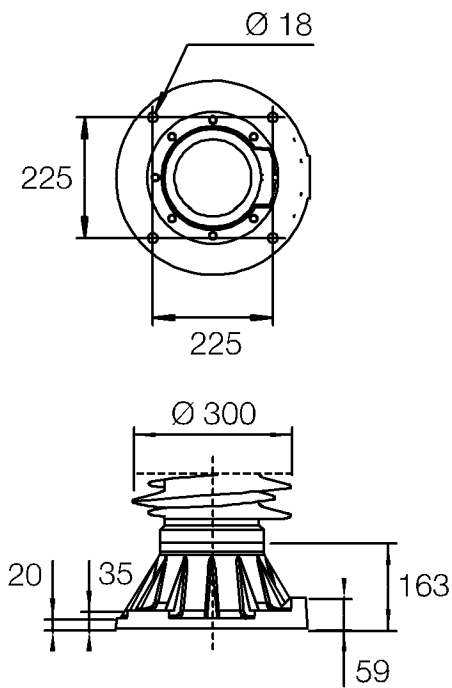

Fig. 7.1.1
Drilling plan

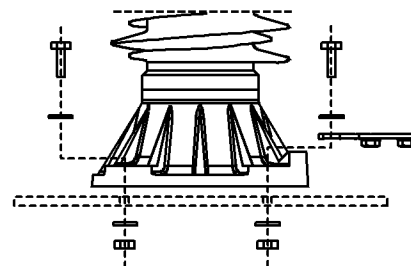

Fig. 7.1.2
Assembly of earth terminal and
installation on structure

Installation on structure

7.2 Installation on structure with insulating base

This instruction covers insulating base 1HSA430 000-P. In the case where another insulating base is to be fitted, the installation instructions included with the delivery shall be followed.

Ensure that the distance between the drilling holes in the structure are according to the corresponding figure 7.2.1.

Fit the insulating base and earth terminal to the bottom flange of the bottom unit. Anchoring bolts and nuts are not provided with the arrester.

The extra long bolt M16x160 delivered together with the insulating base is only used for connecting the diagnostic indicator EXCOUNT-II. See figure 7.2.3. If EXCOUNT-II is not to be mounted, the shorter bolt M16x130 shall be used instead, see figure 7.2.2. The extra long bolt is accordingly disregarded.

Recommended tightening torque is 183 Nm.

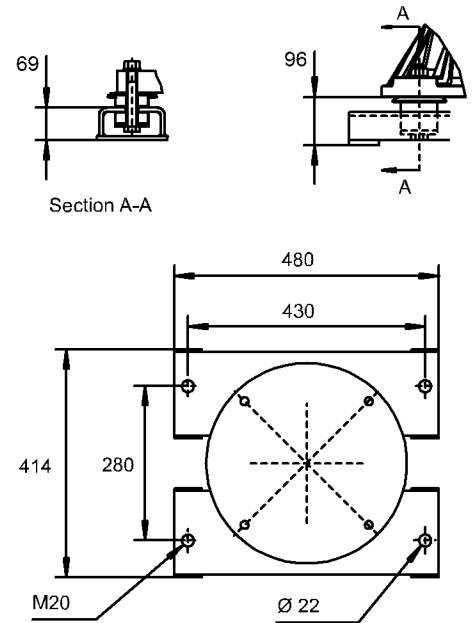

Fig. 7.2.1
Drilling plan

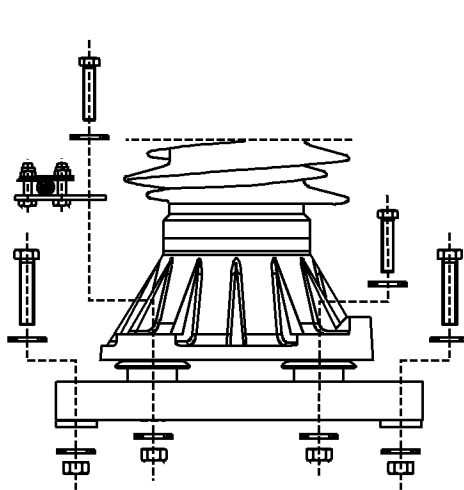
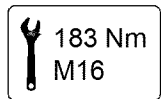

Fig. 7.2.2
With earth terminal and/or
surge counter EXCOUNT-A
and EXCOUNT-I

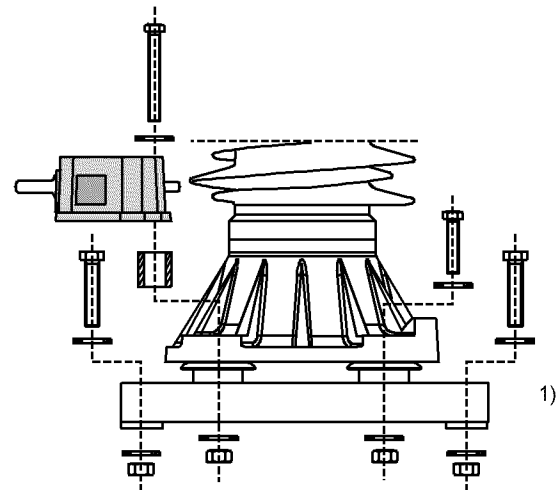

Fig. 7.2.3
With diagnostic indicator EXCOUNT-II

1) Requirements on M16 bolts for installation to structure:

These bolts are not supplied with the arrester.

Recommended tightening torque: Acc. to strength class. max 240 Nm.

Strength class: 8.8 or higher

Material: Hot dip galvanized steel or waxed stainless steel.

Required threaded grip length: 15 to 20 mm.

A washer shall be placed under the bolts head..

8. Connection of conductors

8.1 Mechanical load of the surge arrester

Surge arresters are dimensioned for use at an operating voltage that is equal to or lower than the continuous operating voltage U_c (as per IEC) or MCOV (as per ANSI), as is shown on the rating plate.

Surge arresters are dimensioned to withstand bending moments according to table 8.1. To obtain the best protection performance, the arresters must be connected with as short connectors as possible to both line and earth. However the mechanical aspects must be taken into consideration. Connectable diameter for terminals with clamps is 8-34 mm.

Table 8.1

Service loading	HS PEXLIM P-T and T-T
Specified long-term load (SLL)	19 000 Nm
Specified short-term load (SSL)	28 000 Nm
Definitions as per IEC 60099-4	

Connection of conductors

8.2 Connection of the conductor

Connection of the conductor must be done correctly. For vertical mounting the conductor must be fixed edge to edge with the clamp.

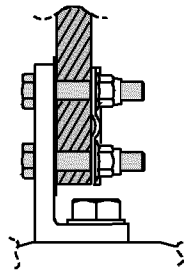

Figure 8.2.1
Correct
installation

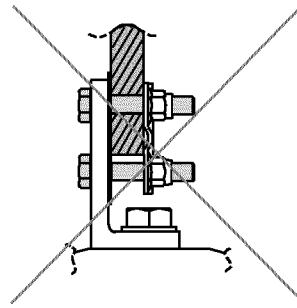

Figure 8.2.2
Warning!
Faulty connection



Compatible conductor material

All earth terminals are compatible with both copper and aluminium conductors, as are all line terminals except 1HSA410 000-A, -C and H which cannot be combined with copper conductors. In these cases use stainless steel washers between the aluminium terminal and the copper conductor.

Connection of conductors

8.3 Connection of the conductor to the line terminal

Connect the line conductor to the line terminal in such way that the permissible static loading together with steady wind load does not exceed the maximum value according to table 8.1 on page 18.

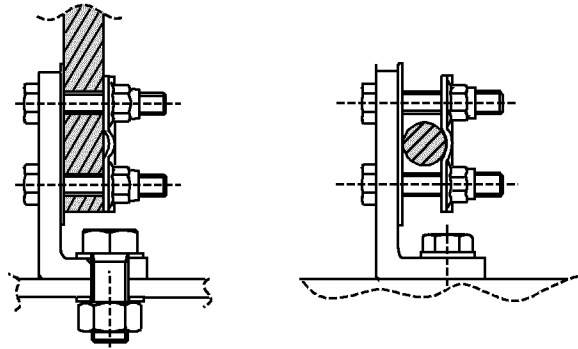

Fig 8.3.1
Connection of single line conductor
can be done from top or side

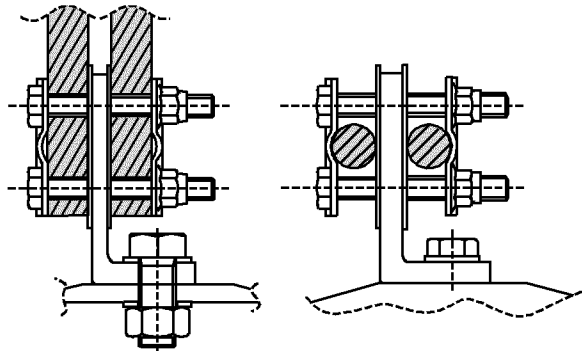

Fig 8.3.2
Connection of double line conductor
can be done from top or side.

Connection of conductors

8.4 Connection of the conductor to the earth terminal

The earth conductor cross section shall be chosen in accordance with local regulations and earth fault current requirements. For assembly of earth terminal to flange, see figure 7.1.2 on page 16. For assembly of clamp see figure 8.4.

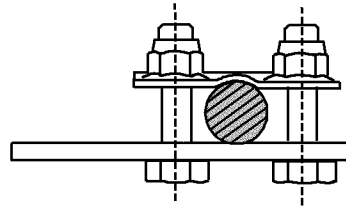

Fig 8.4

Connection of conductors

8.5 Installation of surge counter or EXCOUNT-II

For installation of surge arrester monitor EXCOUNT-II, see section 7.2 on page 17 together with the separate assembly instruction included with the delivery.

For installation of a surge counter EXCOUNT-A, EXCOUNT-I or surge counter from another manufacturer, ensure that:

- The arrester is insulated from the structure by an insulating base with a LIWL of at least 15 kV or equal to that of the conductor between the surge arrester and the surge counter (see below), whichever is the greater.
- The length of the conductor between the arrester and the surge counter is to be minimum 0,5 m when a clip-on CT is to be used for control measurements of leakage current. The maximum length shall not exceed 3 m in the case of the insulating base and conductor having a LIWV of 15 kV. Longer lengths up to 10 m could be used with an insulating base having suitably higher LIWV. The insulated base and conductor shall then be insulated for $5 \times L$ kV (LIWV), where L is the conductor length in meters as shown in figure 8.5. Note that connection leads should always be kept as short as possible as longer leads result in a disadvantage from a protection point of view since inductance is added in series with the arrester.
- The conductor from the earth terminal of the counter to connection with the grounded support stand (point A in figure 8.5) on to which the counter is attached (or similar support) shall not exceed 0,5 m. For example, length B as shown in figure 8.5. The earth conductor may be extended from the connection point at the support to any "earth point" if the support itself, due to local requirements, is not considered as sufficiently grounded. However a flashover of the arrester base may occur if the length (L+B in figure 8.5) results in the LIWV as described above being exceeded and the counter may be damaged if the length B exceeds 0.5 m.
- The surge counter is to be installed according to the included assembly instruction.

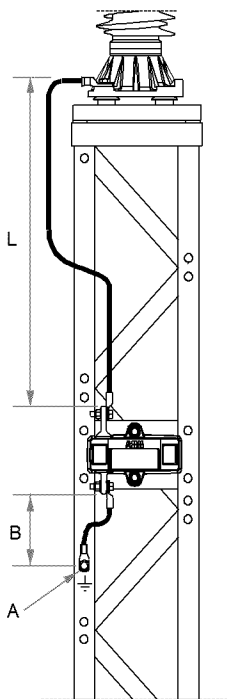

Fig 8.5

Standard ABB insulated base	Maximum length L *)
1HSA430 000-A, -B	10 m
1HSA430 000-C, -D	10 m
1HSA430 000-H, -J	10 m
1HSA430 000-P	3 m

*) On the condition the connecting conductor has at least $LIWV = 5 \times L$ kV

9. Maintenance

9.1 Maintenance and checking

A properly chosen and installed HS PEXLIM P-T and T-T surge arrester is maintenance free during its lifetime, when operating under normal operating conditions. A properly chosen arrester means that both its electrical capability as well as its mechanical design correspond to the service conditions of the actual network.

Cleaning

PEXLIM arresters do not require any cleaning of the external surfaces for their lifetime. The surface may appear to be dirty, but this is of no significance.

Should however for any reason the arresters be subjected to live washing observe the following in addition to normal precautions for live washing:

- Arrester insulators usually have shorter flash-over distances than other insulators for the same system voltage, which means a higher risk for external flash-over during washing.
- Arresters must be spray-washed evenly in order to avoid overheating. Do not use high pressure on the water.

For extreme environments (e.g. high acidity, cement) please contact ABB.

General

Should a routine check be desired, the only reliable method is to periodically measure the resistive component of the leakage current. For this purpose, use of ABB Leakage Current Monitor, LCM, together with ABBs clip-on current meter or ABB diagnostic indicator EXCOUNT-II is recommended. For description of the LCM/EXCOUNT-II and measurement procedures, please refer to relevant catalogues.

Indications of arrester failure due to overstress

A red plastic cover covers each venting duct of the arrester. Check that these covers are in position before installation. In the event of an arrester failure due to overstress, one of the indications may be the blowing of these covers. Other indications may be soot marks around the venting ducts.

10. Disposal

10.1 Disposal of the surge arrester

When the surge arrester is taken out of service due to age or in case of an arrester failure due to overstress, its components shall be taken care of according to local regulations. The composition of the arrester and its components is shown in the figure below

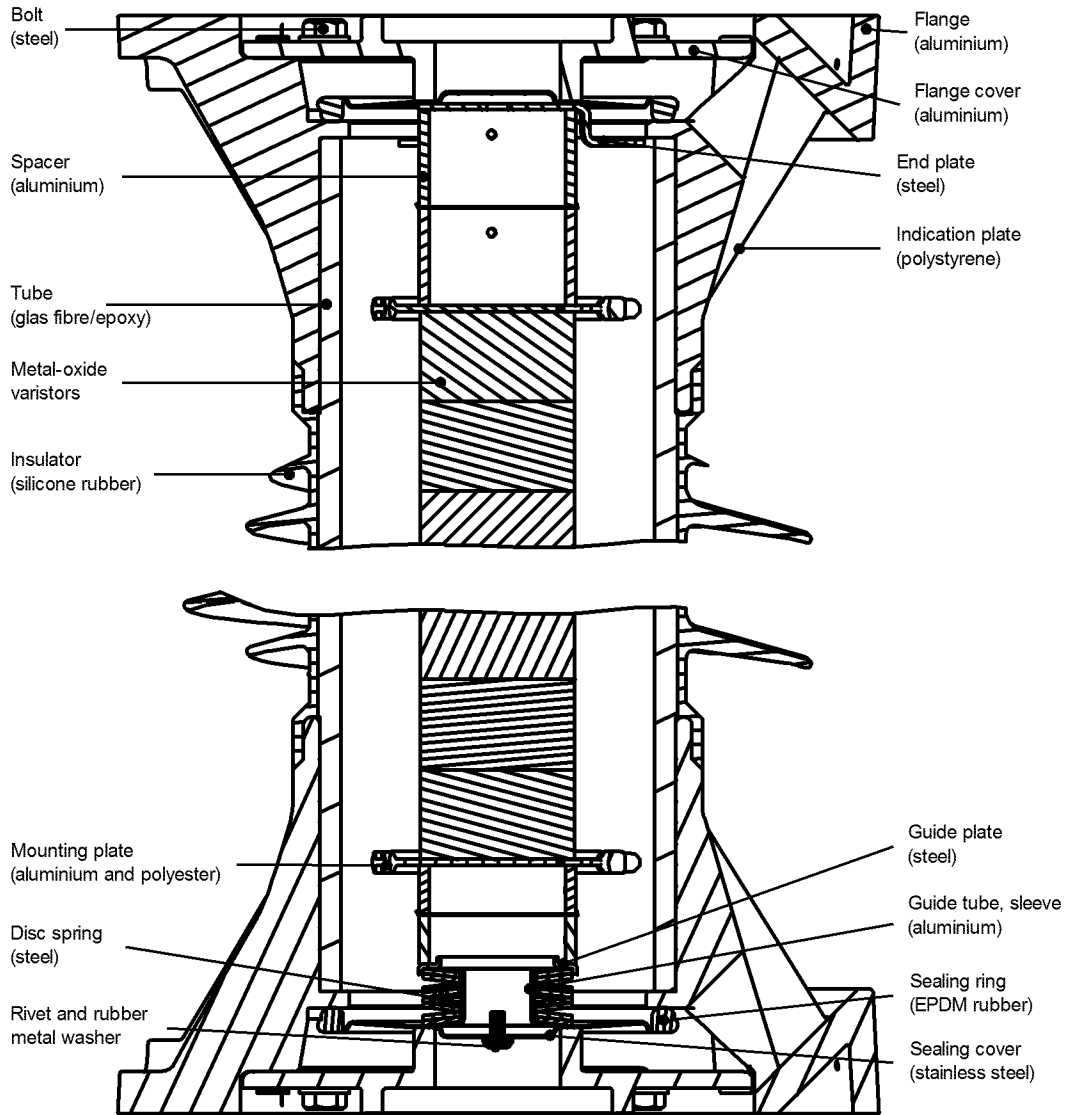

Disposal

Handling of HS HS PEXLIM P-T and T-T Metal-Oxide Surge Arresters taken out of Service

A surge arrester type HS HS PEXLIM P-T and HS HS PEXLIM T-T consists of an outer hollow insulator made of non-halogenated silicon rubber on a fibre-glass reinforced epoxy tube with end fittings and terminals made of aluminium. The inside of the arrester consists of metal oxide varistors, components out of steel, aluminium and polyester and EPDM gaskets. Each arrester unit also contains small packages of desiccant of silica gel.

The metal-oxide varistors are sintered bodies composed mainly of ZnO (90%), with the following other substances in more than 1% weight (in accordance with the common market rules for hazardous components):



For hazardous substances (according to the Council Directive 91/689/EEG on hazardous waste), the following substances are existing in more than 0,1% weight but less than 1%:

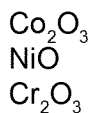

In addition the metal-oxide varistors are coated with a thin glass layer (<0,1% weight) containing PbO.

When the arrester is disposed of the polymer parts will eventually decompose into SiO_2 and CO_2 . As the substances of the sintered metal-oxide varistors exists in an oxidized state, a leaching test according to EPA-test (Federal Register / vol.45, No 98 / Rules and Regulation), has shown that the sintered bodies may be disposed of without violating the EEG Directive.

Contact us

ABB AB
High Voltage Products
Surge Arresters
S-771 80 LUDVIKA, SWEDEN

Phone: +46 (0)240 78 20 00
Telefax: +46 (0)240 179 83

E-mail: arresters.div@se.abb.com
Internet: <http://www.abb.com/arrestersonline>

©Copyright 2011 ABB
All rights reserved

NOTE! ABB is working with continuous improvements, therefore we reserve the right to change design and specifications without notice.

Document: I1HSA 801 080-06en, Assembly instruction HS PEXLIM P-T and T-T, Edition 4, 2011-12

Power and productivity
for a better world™



SB_GT&S_0443259