

# R&D and Innovation for PG&E Gas Operations

François Rongere  
CPUC June 20<sup>th</sup>, 2014





# R&D and Innovation part of Gas Safety Excellence

- Innovation is key to improve Gas Safety at an affordable cost.
- PG&E has introduced a systematic risk-based management of its assets following the continuous improvement Plan, Do, Check, Act sequence based on the ISO 55001 standard.
- R&D and Innovation is used to improve tools and methods and is part of the Act phase of the Gas Safety Excellence sequence.

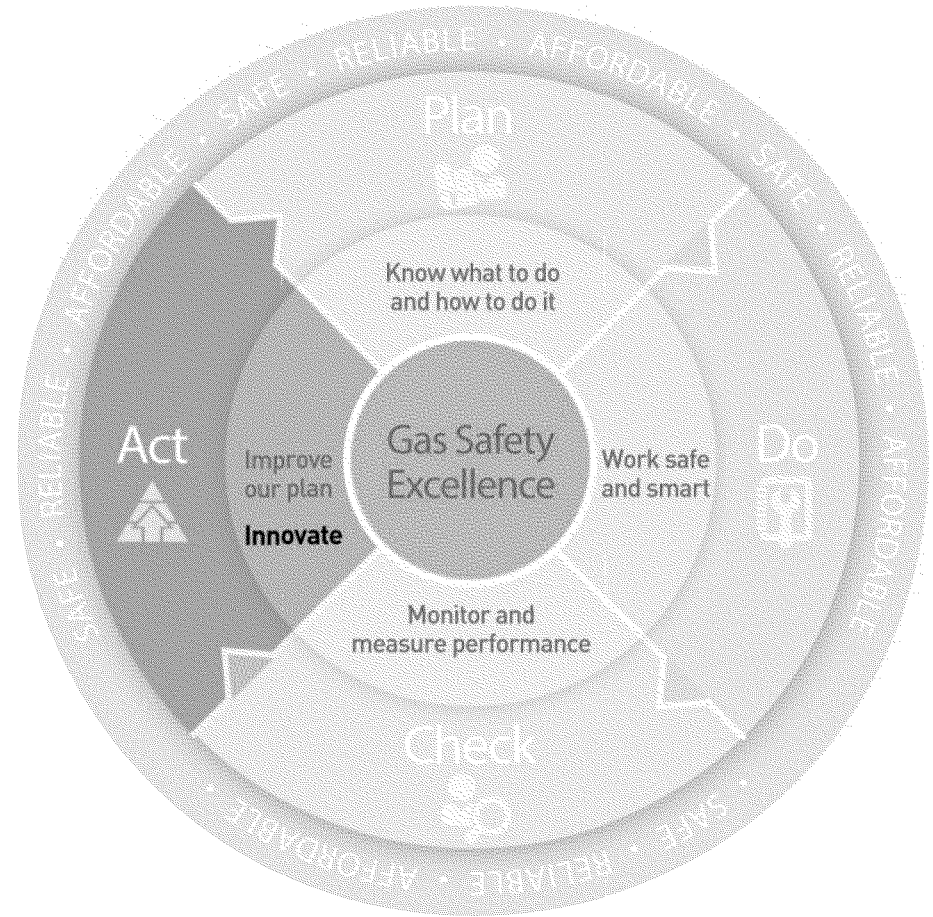



# R&D and Innovation Portfolio

■ 92 active projects, 33 in evaluation (as of May 31<sup>st</sup>, 2014)

## Current R&D and Innovation Portfolio leveraging collaborative R&D

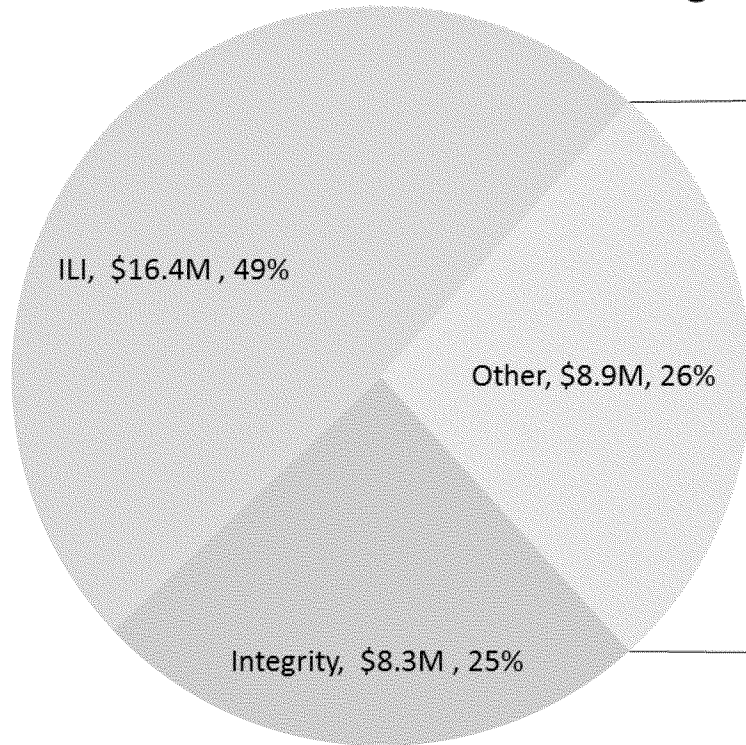

**TOTAL: \$34M for \$4.9M PG&E funding**  
Leverage Factor: 7

System Operation and Control	\$0.1M
Emergency Preparedness	\$0.1M
Excavation Technologies	\$0.5M
Data/Asset Knowledge Management,	\$0.5M , 2%
Facilities,	\$1.5M , 4%
Instrumentation and Regulation,	\$1.5M , 4%
Damage Prevention,	\$2.1M , 6%
Leak/Emergency response,	\$2.4M , 7%

**NOTE:**

Numbers represent overall project costs supported by all funders, PG&E's share is about 7 times less.  
Numbers are not Annual Budget. Projects may be longer or shorter than a year.



# R&D and Innovation Connection

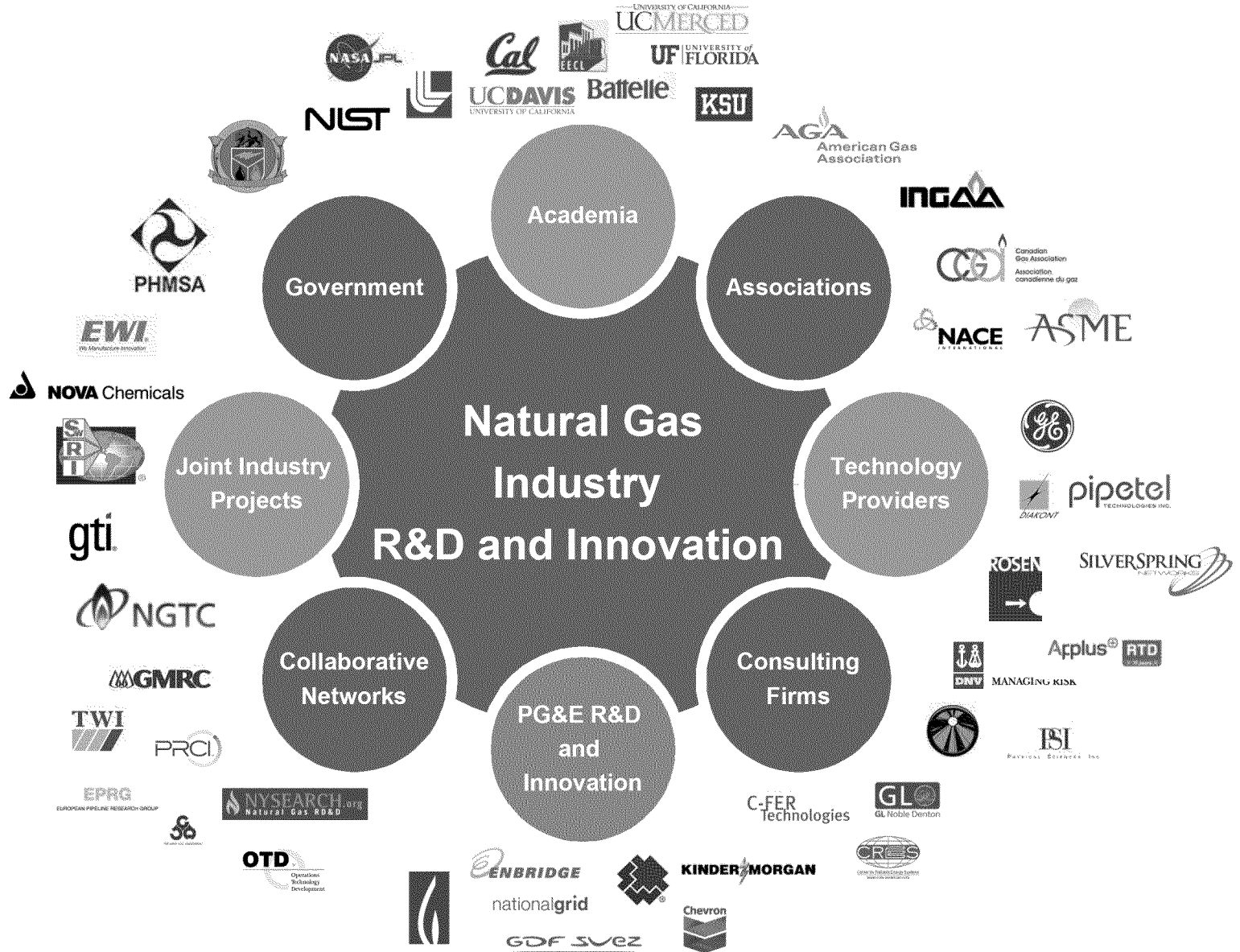



# Success Stories



# Explorer Robotic Tools

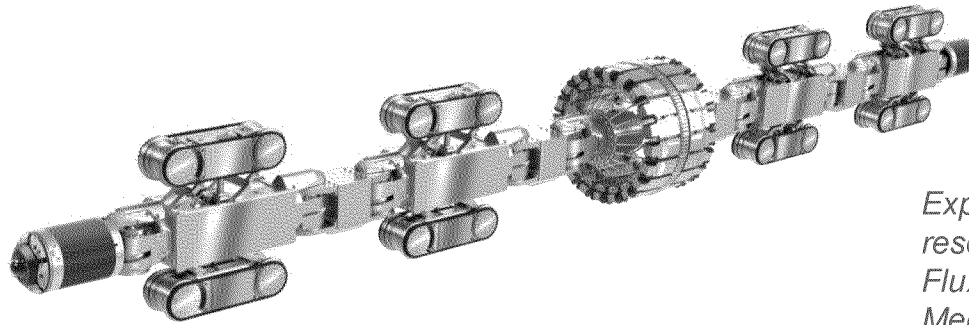

*Explorer 20/26 with high resolution cameras, Magnetic Flux Leakage sensor, and Mechanical Damage Sensor*

- Non-tethered, battery-powered in-line inspection robotic tools for unpiggable transmission pipelines.
- Key Features:
  - Launch and receive through pressure control fitting via hot tap (traditional pig launcher and receiver not required)
  - Navigates through “unpiggable” features:
    - Mitered and < 1.5D radius bends
    - Plug valves
    - Low pressure and flow conditions
  - Performs NDE (Non-Destructive Evaluation) and visual inspection (2 high resolution cameras) for metal loss, cracks, and mechanical damage.



# Explorer Robotic Tools

Platform	Status
Explorer 6/8	<ul style="list-style-type: none"><li>- Remote Field Eddy Current (RFEC) version commercially available.</li><li>- Magnetic Flux Leakage (MFL) versions in development, expected commercial availability expected 4Q 2015.</li></ul>
Explorer 10/14	<ul style="list-style-type: none"><li>- MFL version commercially available.</li><li>- Deployed twice at PG&amp;E.</li></ul>
Explorer 16/18	<ul style="list-style-type: none"><li>- Currently in development (PG&amp;E not funding due low mileage in this diameter range).</li><li>- Expected commercial availability expected 2Q 2015</li></ul>
Explorer 20/26	<ul style="list-style-type: none"><li>- MFL version commercially available.</li><li>- Deployed once at PG&amp;E.</li></ul>
Explorer 30/36	<ul style="list-style-type: none"><li>- PG&amp;E hosted the first demonstration of this largest platform in July 2013. Currently awaiting final field test on the East Coast.</li><li>- Commercial availability expected 4Q 2014.</li></ul> 



# Explorer Sensors & Technologies

## Mechanical Damage Sensor

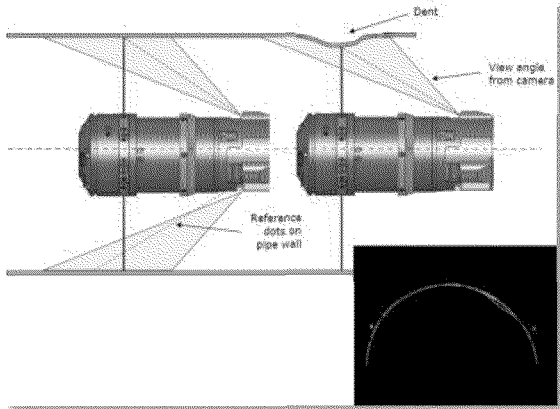

Laser-based sensor detects and measures mechanical damage and ovality

## Crack Sensor

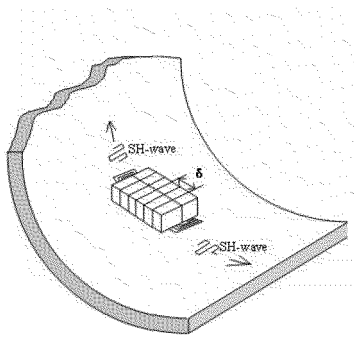

Combination of Electromagnetic Acoustic Transducer (EMAT) and Transverse MFL to detect cracks *(in development)*

## In-Line Charging Tool

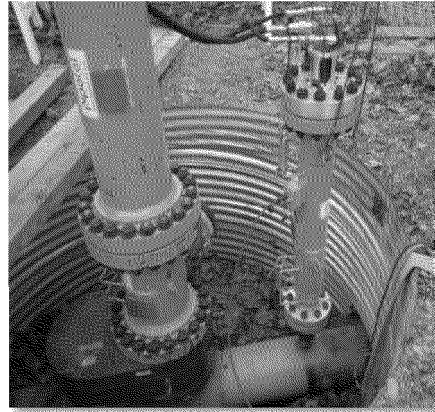

Charges batteries of Explorer tools through a hot tap to extend range of inspection.

## Rescue Tool

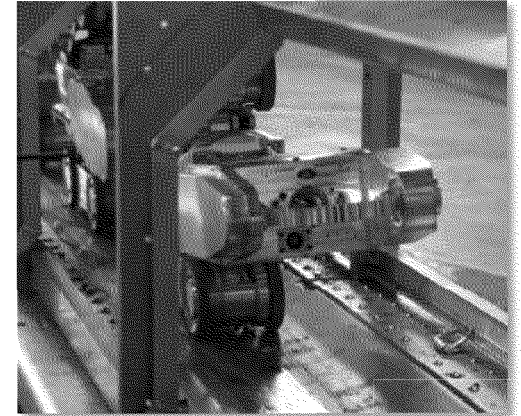

## Pipeline Cleaning Tool

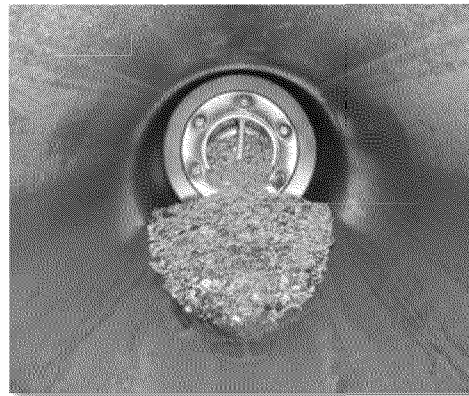





# High Sensitivity Methane Detector

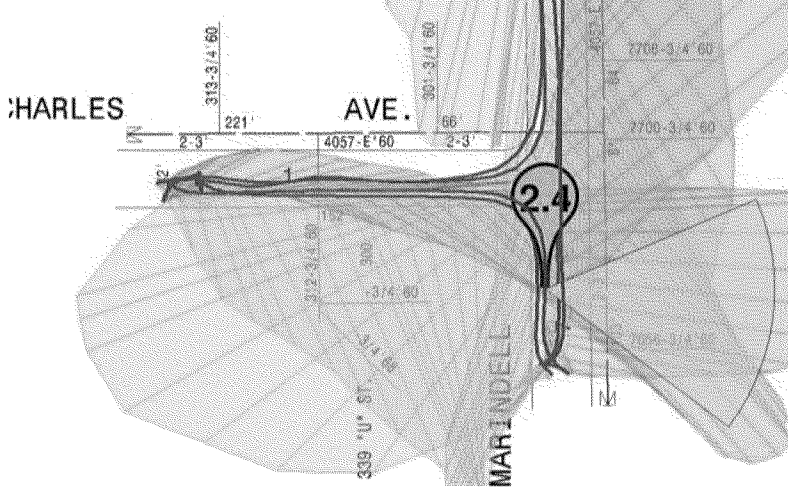
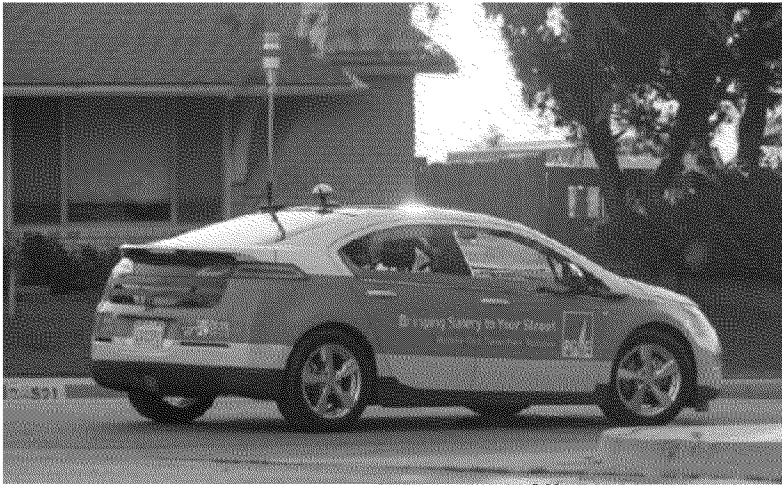

- Cavity Ring Down Spectroscopy (CRDS) detects methane concentrations as low as 1ppb.
- Allows a more effective sweep of an area with a vehicle to identify possible leaks.
- Data are transmitted immediately and can be viewed remotely in real time.
- Offers many opportunities to improve leak detection and repair process.





# Light Weight Methane Detector to Rapidly Locate Leaks



Prototype of Methane Detector by JPL (March 2013)

- Jet Propulsion Laboratory of NASA in Pasadena has developed a miniaturized methane detector to locate methane sources on Mars
- Precision of 10 ppb with an open path of 20 cm by using 3.3  $\mu\text{m}$  absorption band.
- Allows to go from Picarro methane indication to leak by tracking the plume.
- Can be mounted on a UAV for rough terrain pipeline survey
- Partnership with PRCI and JPL to complete development and adaptation to our needs

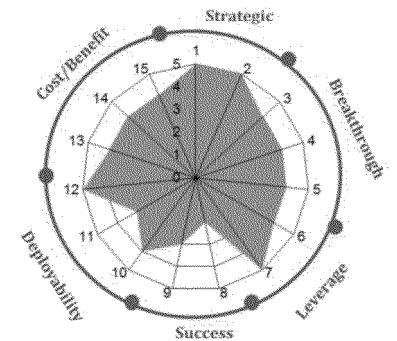



# 3D Toolbox: 3D Structured Light Measurement System

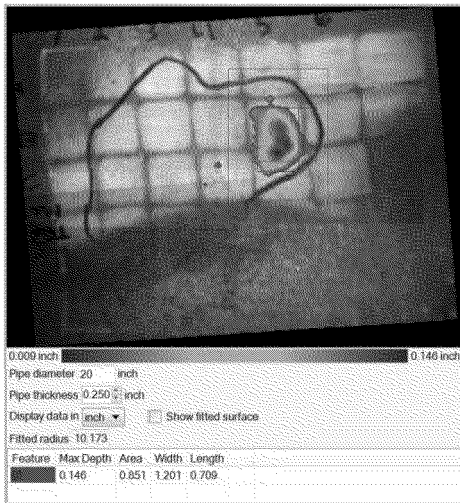
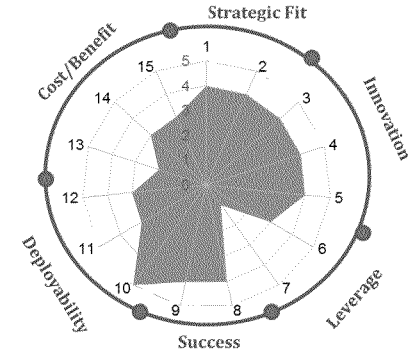
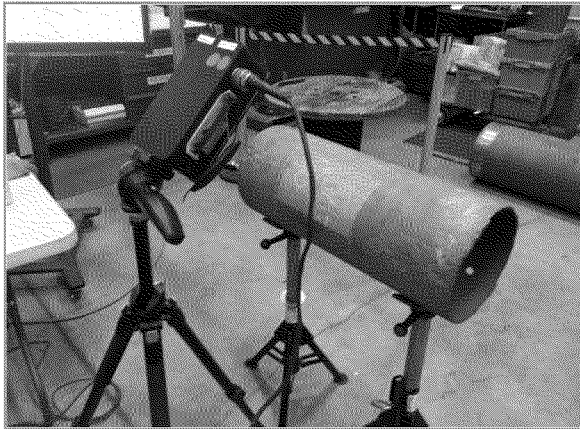

- First developed for the dental industry, as a spin-off from University of Kentucky, the 3D Toolbox was detected by PRCI through the NASA Tecfusion program.
- Used like a digital camera, 3D Toolbox captures 3D images of pipe surfaces and provides measurements and analyses of the surface condition.
- PG&E verified the tool performance through a series of lab and field tests and is in the final stages of its deployment.





# GPS-based Damage Prevention



- Supplements 811 calls to provide additional protection
- Uses GPS location of construction equipment and movement patterns
- Sends alerts to field operators, and utility control room when equipment digs close to underground assets
- Built upon development made by GTI with Virginia Utility Protection Services
- Solution expected to be cheaper and more effective than ultrasonic and fiber optic detection systems

2013

Design

Develop

Test

2015

Deploy

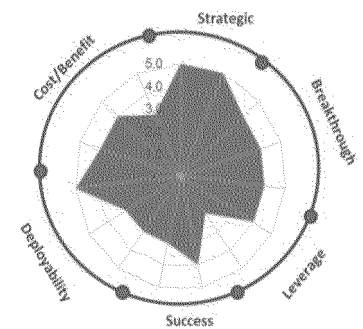



# Thank you!

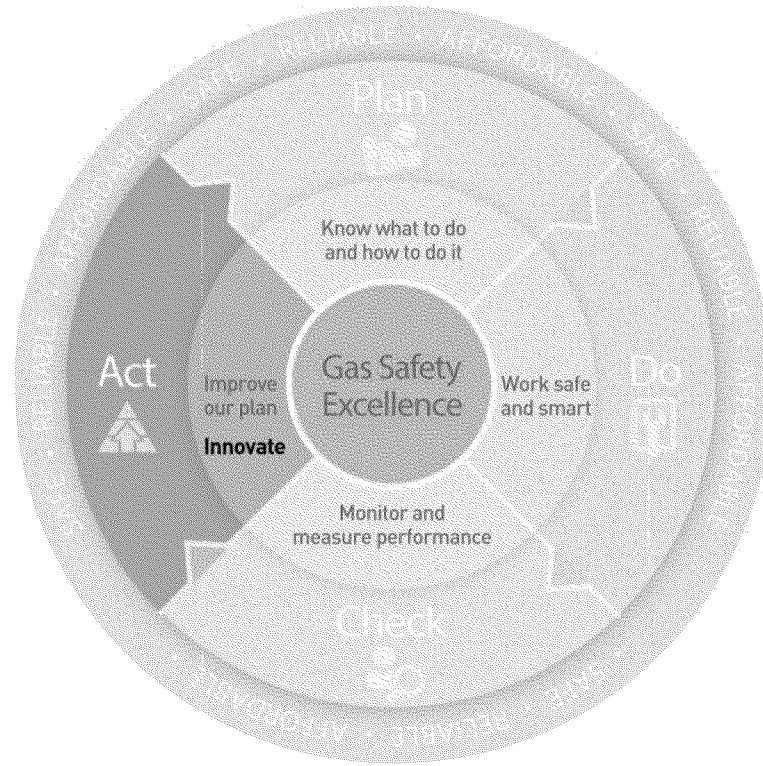

**François Xavier Rongere**  
**PG&E Gas Operations**  
**R&D and Innovation**  
Tel: (925) 244-3070  
Cel: (415) 517-0946  
E-mail: fxrg@pge.com