

**SMALL RENEWABLE GENERATOR
POWER PURCHASE AGREEMENT**

BETWEEN

Pristine Sun LLC **AND**

PACIFIC GAS AND ELECTRIC COMPANY

PACIFIC GAS AND ELECTRIC COMPANY, a California Corporation (“PG&E” or “Buyer”), and Pristine Sun LLC (“Seller”) hereby enter into this Power Purchase Agreement (“Agreement”). Seller and PG&E are sometimes referred to in this Agreement jointly as “Parties” or individually as “Party.” In consideration of the mutual promises and obligations stated in this Agreement and its appendices, the Parties agree as follows:

1. **DOCUMENTS INCLUDED; DEFINED TERMS**

This Agreement includes the following appendices, which are specifically incorporated herein and made a part of this Agreement.

Appendix A - Definitions

Appendix B - Initial Energy Delivery Date Confirmation Letter

Appendix C - Time of Delivery (“TOD”) Periods and Factors

Appendix D - Counterparty Notification Requirements for Outage and Generation Schedule Changes

Appendix E - Description of the Facility

2. **SELLER’S GENERATING FACILITY, PURCHASE PRICES AND PAYMENT**

2.1 **Facility.** This Agreement governs PG&E’s purchase of the Product from the electrical generating facility (hereinafter referred to as the “Facility” or “Unit” or “Project”) as described in this Section.

2.1.1 The Facility is located at:

910 Nacimiento Lake Drive

Paso Robles

CA 93446

San Luis Obispo County, California.

2.1.2 The Facility is named 2056- Jardine.

2.1.3 The Facility's primary fuel is PV Solar [i.e. biogas, hydro, etc.].

2.1.4 The Facility has a Nameplate of 1000 kilowatts ("kW"), at unity power factor at 60 degrees Fahrenheit at sea level and has a primary voltage level of 480 kilovolts ("kV"). Seller shall not modify the Facility to increase the Nameplate without the prior written consent of PG&E. The Nameplate will be net of any Station Use, or in the case of solar it will be net of any inverter losses. The Nameplate will not exceed 1,500 kW.

2.1.5 The Facility is connected to the PG&E electric system at 480 kV.

2.1.6 If not already capable of delivering energy on the Execution Date, the Facility's scheduled Commercial Operation Date is September 30, 2012.

2.1.7 A description of the Facility, including a summary of its significant components, a drawing showing the general arrangements of the Facility, and a single line diagram illustrating the interconnection of the Facility and loads with PG&E's electric distribution or transmission system, is attached and incorporated herein as Appendix E.

2.1.8 The name and address PG&E uses to locate the electric service account(s) and premises used to interconnect the Facility with PG&E's distribution systems is:

910 Nacimiento Lake Drive

Paso Robles

CA 93446

2.2 Transaction. During the Delivery Term of this Agreement, as provided in Section 2.3, Seller shall sell and deliver, or cause to be delivered, and PG&E shall purchase and receive, or cause to be received, the Product from the Facility, up to 1,500 kW, at the Delivery Point, as defined pursuant to Section 5.1, pursuant to Seller's election of a (check one) full buy/sell or excess sale arrangement as described in paragraphs 2.2.1 and 2.2.2 below. PG&E shall pay Seller the Contract Price, set forth in Section 2.4, in accordance with the terms hereof. In no event shall Seller have the right to procure the Product from sources other than the Facility for sale or delivery to PG&E under this Agreement or substitute such Product. PG&E shall have no obligation to receive or purchase the Product from Seller prior to the Initial Energy Delivery Date, as defined in Section 2.3, or after the end of the Delivery Term, as defined in Section 2.3.

2.2.1 Full Buy/Sell. Seller agrees to sell to PG&E the Facility's gross output in kilowatt-hours, net of Station Use and transformation and transmission losses to the Delivery Point into the PG&E system, together with all Green Attributes and Resource

Adequacy Benefits. Seller shall purchase all energy required to serve the Facility’s on-site load, net of Station Use, from PG&E pursuant to PG&E’s applicable retail rate schedule.

2.2.2 Excess Sale. Seller agrees to sell to PG&E the Facility’s gross output in kilowatt-hours, net of Station Use and any on-site use by Seller and transformation and transmission losses to the Delivery Point into the PG&E system. Seller agrees to convey to PG&E all Green Attributes and Resource Adequacy Benefits associated with the energy sold to PG&E.

2.3 Delivery Term. The Seller shall deliver the Product from the Facility to PG&E for a period of (check one) ten (10), fifteen (15), or twenty (20) Contract Years (“Delivery Term”), which shall commence on the first date on which energy is delivered from the Facility to PG&E (“Initial Energy Delivery Date”) under this Agreement and continue until the end of the last Contract Year unless terminated by the terms of this Agreement. The Initial Energy Delivery Date shall occur only when all of the following conditions have been satisfied:

(i) the Commercial Operation Date has occurred, if the Facility was not in operation prior to the Execution Date of this Agreement;

(ii) the Facility’s status as an Eligible Renewable Energy Resource, is demonstrated by Seller’s receipt of certification from the California Energy Commission (“CEC”) and is registered in WREGIS; and

(iii) as evidence of the Initial Energy Delivery Date, the Parties shall execute and exchange the “Initial Energy Delivery Date Confirmation Letter” attached hereto as Appendix B on the Initial Energy Delivery Date.

2.4 Contract Price. PG&E shall pay Seller for each kilowatt hour (“kWh”) of the Product delivered to PG&E during each Contract Year for the Delivery Term at the applicable Market Price Referent specified below for the Facility’s actual Commercial Operation Date. Payment shall be adjusted by the appropriate Time of Delivery (“TOD”) factor listed in Appendix C.

Adopted 2009 Market Price Referents¹			
(Nominal - dollars/kWh)			
Resource Type	10-Year	15-Year	20-Year
2010 Baseload MPR	0.08448	0.09066	0.09674
2011 Baseload MPR	0.08843	0.09465	0.10098
2012 Baseload MPR	0.09208	0.09852	0.10507
2013 Baseload MPR	0.09543	0.10223	0.10898
2014 Baseload MPR	0.09872	0.10593	0.11286

¹ Note: Using 2010 as the base year, Staff calculates MPRs for 2010-2021 that reflect different project online dates. Link to 2009 MPR Model: <http://www.epuc.ca.gov/PUC/energy/Renewables/mpr>

2015 Baseload MPR	0.10168	0.10944	0.11647
2016 Baseload MPR	0.10488	0.11313	0.12020
2017 Baseload MPR	0.10834	0.11695	0.12404
2018 Baseload MPR	0.11204	0.12090	0.12800
2019 Baseload MPR	0.11598	0.12499	0.13209
2020 Baseload MPR	0.12018	0.12922	0.13630
2021 Baseload MPR	0.12465	0.13359	0.14064

2.5 Billing. PG&E shall pay Seller by check or Automated Clearing House transfer within approximately thirty (30) days of the meter reading date if the value of the purchased Product in a month is at least fifty dollars (\$50); if less, PG&E may pay Seller quarterly. PG&E shall have the right, but not the obligation, to read the Facility's meter on a daily basis.

2.6 Title and Risk of Loss. Title to and risk of loss related to the Product from the Facility shall transfer from Seller to PG&E at the Delivery Point. Seller warrants that it will deliver to PG&E the Product from the Facility free and clear of all liens, security interests, claims and encumbrances or any interest therein or thereto by any person arising prior to the Delivery Point.

2.7 No Additional Incentives. Seller agrees that during the Term of this Agreement, Seller shall not seek additional compensation or other benefits pursuant to the Self-Generation Incentive Program, as defined in California Public Utilities Commission ("CPUC") Decision ("D.") 01-03-073, the California Solar Initiative, as defined in CPUC D.06-01-024, PG&E's net energy metering tariff, or other similar California ratepayer subsidized program relating to energy production with respect to the Facility.

2.8 Private Energy Producer. Seller agrees to provide to Buyer copies of each of the documents identified in California Public Utilities Code ("PUC") Section 2821(d)(1), if applicable, as may be amended from time to time, as evidence of Seller's compliance with such PUC section. Such documentation shall be provided to Buyer within thirty (30) days of Seller's receipt of written request.

3. GREEN ATTRIBUTES; RESOURCE ADEQUACY BENEFITS; EIRP REQUIREMENTS; ERR REQUIREMENTS

3.1 Green Attributes. Seller hereby provides and conveys all Green Attributes associated with all electricity generation from the Project to Buyer as part of the Product being delivered. Seller represents and warrants that Seller holds the rights to all Green Attributes from the Project, and Seller agrees to convey and hereby conveys all such Green Attributes to Buyer as included in the delivery of the Product from the Project.

3.2 WREGIS. Prior to the Initial Energy Delivery Date, Seller shall register the Facility in WREGIS and take all other actions necessary to ensure that the energy produced

from the Facility is tracked for purposes of satisfying the California Renewables Portfolio Standard requirements, as may be amended or supplemented by the CPUC or CEC from time to time. Seller warrants that all it shall take all necessary steps to ensure the Renewable Energy Credits transferred to Buyer under this Agreement are tracked in WREGIS and transferred in a timely manner to Buyer through WREGIS for purposes of satisfying Buyer's California Renewables Portfolio Standard Requirements, as may be amended or supplemented by the CPUC or CEC from time to time.

3.2.1 A "WREGIS Certificate Deficit" means any deficit or shortfall in WREGIS Certificates delivered to Buyer for a calendar month as compared to the metered energy for the same calendar month ("Deficient Month"). If any WREGIS Certificate Deficit is caused, or the result of any action or inaction, by Seller, then the amount of the Product in the Deficient Month shall be reduced by the amount of the WREGIS Certificate Deficit for the purposes of calculating Buyer's payment(s) to Seller. Any amount owed by Seller to Buyer because of a WREGIS Certificate Deficit shall be made as an adjustment to Seller's next monthly invoice to Buyer, and Buyer shall net such amount against Buyer's subsequent payment(s) to Seller.

3.2.2 Seller warrants that all necessary steps to allow the Renewable Energy Credits transferred to Buyer to be tracked in the Western Renewable Energy Generation Information System will be taken prior to the first delivery under the contract.

3.3 Resource Adequacy Benefits. In accordance with PUC Section 399.20(g), Seller conveys to PG&E all Resource Adequacy Benefits attributable to the physical generating capacity of Seller's Facility to enable PG&E to count such capacity towards PG&E's resource adequacy requirement for purposes of PUC Section 380. Seller shall take all reasonable actions and execute documents and instructions necessary to enable Buyer to secure Resource Adequacy Benefits; Seller shall comply with all applicable reporting requirements.

3.4 Eligible Renewable Resource. Seller will use commercially reasonable efforts to achieve and maintain status as an Eligible Renewable Energy Resource or ERR per the meaning set forth in California Public Utilities Code Section 399.12 and California Public Resources Code Section 25741, as either code provision is amended or supplemented from time to time.

[The following Section 3.5 Eligible Intermittent Resources Protocol Requirements applies only to Facilities greater than 1.0 MWs]

3.5 Eligible Intermittent Resources Protocol ("EIRP") Requirements. Seller shall provide Buyer with a copy of the notice from CAISO certifying the Facility as a Participating Intermittent Resource as soon as practicable after Seller's receipt of such notice of certification. Following such certification: (i) Seller at its sole cost shall participate in and comply with EIRP and all additional protocols issued by the CAISO relating to Participating Intermittent Resources (as defined in the CAISO Tariff), and (ii) Buyer in its limited capacity as Seller's Scheduling Coordinator shall facilitate

communication with the CAISO and provide other administrative materials to the CAISO as necessary to satisfy Seller's obligations and to the extent such actions are at *de minimis* cost to Buyer.

4. REPRESENTATION AND WARRANTIES; COVENANTS

4.1 Representations and Warranties. On the Execution Date, each Party represents and warrants to the other Party that:

4.1.1 it is duly organized, validly existing and in good standing under the laws of the jurisdiction of its formation;

4.1.2 the execution, delivery and performance of this Agreement is within its powers, have been duly authorized by all necessary action and do not violate any of the terms and conditions in its governing documents, any contracts to which it is a party or any law, rule, regulation, order or the like applicable to it;

4.1.3 this Agreement and each other document executed and delivered in accordance with this Agreement constitutes its legally valid and binding obligation enforceable against it in accordance with its terms;

4.1.4 it is not bankrupt and there are no proceedings pending or being contemplated by it or, to its knowledge, threatened against it which would result in it being or becoming bankrupt;

4.1.5 there is not pending or, to its knowledge, threatened against it or any of its affiliates any legal proceedings that could materially adversely affect its ability to perform its obligations under this Agreement; and

4.1.6 it is acting for its own account, has made its own independent decision to enter into this Agreement and as to whether this Agreement is appropriate or proper for it based upon its own judgment, is not relying upon the advice or recommendations of the other Party in so doing, and is capable of assessing the merits of, and understands and accepts, the terms, conditions and risks of this Agreement.

4.2 General Covenants. Each Party covenants that throughout the Term of this Agreement:

4.2.1 it shall continue to be duly organized, validly existing and in good standing under the laws of the jurisdiction of its formation;

4.2.2 it shall maintain (or obtain from time to time as required, including through renewal, as applicable) all regulatory authorizations necessary for it to legally perform its obligations under this Agreement; and

4.2.3 it shall perform its obligations under this Agreement in a manner that does not violate any of the terms and conditions in its governing documents, any contracts to which it is a party or any law, rule, regulation, order or the like applicable to it.

4.3 Seller Representation and Warranty and Covenant.

4.3.1 Representation and Warranty. In addition to the representations and warranties specified in Section 4.1, Seller makes the following additional representations and warranties as of the Execution Date:

(a) The Facility has not received an incentive under the Self-Generation Incentive Program, as defined in CPUC D.01-03-073, the California Solar Initiative, as defined in CPUC D.06-01-024, or PG&E's net energy metering tariff.

(b) Seller's execution of this Agreement will not violate PUC Section 2821(d)(1) if applicable.

(c) Seller, and, if applicable, its successors, represents and warrants that throughout the Delivery Term of this Agreement that: (i) the Project qualifies and is certified by the CEC as an Eligible Renewable Energy Resource ("ERR") as such term is defined in Public Utilities Code Section 399.12 or Section 399.16; and (ii) the Project's output delivered to Buyer qualifies under the requirements of the California Renewables Portfolio Standard. To the extent a change in law occurs after execution of this Agreement that causes this representation and warranty to be materially false or misleading, it shall not be an Event of Default if Seller has used commercially reasonable efforts to comply with such change in law.

(d) Seller and, if applicable, its successors, represents and warrants that throughout the Delivery Term of this Agreement the Renewable Energy Credits transferred to Buyer conform to the definition and attributes required for compliance with the California Renewables Portfolio Standard, as set forth in California Public Utilities Commission Decision 08-08-028, and as may be modified by subsequent decision of the California Public Utilities Commission or by subsequent legislation. To the extent a change in law occurs after execution of this Agreement that causes this representation and warranty to be materially false or misleading, it shall not be an Event of Default if Seller has used commercially reasonable efforts to comply with such change in law.

4.3.2 Covenant. Seller hereby covenants that throughout the Term of the Agreement, the Facility is, or will qualify prior to the Initial Energy Delivery Date, as an ERR, specifically, Seller and, if applicable, its successors, represents and warrants throughout the term of the Delivery Term of each Transaction entered into under this Agreement that: (a) the Unit(s) qualifies and is certified by the CEC as an Eligible Renewable Energy Resource; and (b) the Unit(s) output delivered to Buyer qualifies under the requirements of the California Renewables Portfolio Standard. To the extent a change in law occurs after execution of this Agreement that causes this representation and warranty to

be materially false or misleading, it shall not be an Event of Default if Seller has used commercially reasonable efforts to comply with such change in law.

5. GENERAL CONDITIONS

5.1 Facility Care, Interconnection and Transmission Service. Seller shall execute a Small Generator Interconnection Agreement with PG&E's Generation Interconnection Services Department and pay and be responsible for designing, installing, operating, and maintaining the Facility in accordance with all applicable laws and regulations and shall comply with all applicable PG&E, CAISO, CPUC and FERC tariff provisions, including applicable interconnection and metering requirements. Seller shall also comply with any modifications, amendments or additions to the applicable tariff and protocols. During the Delivery Term, Seller shall arrange and pay independently for any and all necessary costs under any interconnection agreement with PG&E. To make deliveries to PG&E, Seller must maintain an interconnection agreement with PG&E in full force and effect.

5.2 Metering Requirements. Seller shall comply with all applicable rules in installing a meter appropriate for deliveries pursuant to the Full Buy/Sell or Excess Sale arrangement selected in paragraph 2.2, above, which can be electronically read daily by: (a) a telephone and modem; (b) an analog or digital phone connection; or (c) an internet portal address for PG&E's Energy Data Services ("EDS"). Seller shall be responsible for procuring and maintaining the communication link to electronically retrieve this metering data.

5.3 Standard of Care. Seller shall: (a) maintain and operate the Facility and Interconnection Facilities, except facilities installed by PG&E, in conformance with all applicable laws and regulations and in accordance with Good Utility Practices, as defined by PG&E's Wholesale Distribution Tariff and the CAISO Tariff, as they may be amended, supplemented or replaced (in whole or in part) from time to time; (b) obtain any governmental authorizations and permits required for the construction and operation thereof; and (c) generate, schedule and perform transmission services in compliance with all applicable operating policies, criteria, rules, guidelines and tariffs and Good Utility Practices, as provided in clause (a) above. Seller shall reimburse PG&E for any and all losses, damages, claims, penalties, or liability PG&E incurs as a result of Seller's failure to obtain or maintain any governmental authorizations and permits required for construction and operation of the Facility throughout the Term of this Agreement.

5.4 Access Rights. PG&E, its authorized agents, employees and inspectors shall have the right to inspect the Facility on reasonable advance notice during normal business hours and for any purposes reasonably connected with this Agreement or the exercise of any and all rights secured to PG&E by law, or its tariff schedules, PG&E Interconnection Handbook, and rules on file with the CPUC. PG&E shall make reasonable efforts to coordinate its emergency activities with the Safety and Security Departments, if any, of the

Facility operator. Seller shall keep PG&E advised of current procedures for communicating with the Facility operator's Safety and Security Departments.

5.5 Protection of Property. Each Party shall be responsible for protecting its own facilities from possible damage resulting from electrical disturbances or faults caused by the operation, faulty operation, or non-operation of the other Party's facilities and such other Party shall not be liable for any such damages so caused.

5.6 PG&E Performance Excuse: Seller Curtailment.

5.6.1 PG&E Performance Excuse. PG&E shall not be obligated to accept or pay for the Product from the Facility during a Dispatch Down Period, or Force Majeure, as defined in Appendix A.

5.6.2 Seller Curtailment. PG&E may require Seller to interrupt or reduce deliveries of energy: (a) when necessary to construct, install, maintain, repair, replace, remove, or investigate any of its equipment or part of PG&E's transmission system or distribution system or facilities; or (b) if PG&E or the CAISO determines that curtailment, interruption, or reduction is necessary because of a System Emergency, as defined in the CAISO Tariff, Forced Outage, Force Majeure as defined in Appendix A, or compliance with Good Utility Practice, as such term is defined in the CAISO Tariff.

5.7 Notices of Outages. Whenever possible, PG&E shall give Seller reasonable notice of the possibility that interruption or reduction of deliveries may be required.

5.8 Greenhouse Gas Emissions: During the Term, Seller acknowledges that a Governmental Authority may require Buyer to take certain actions with respect to greenhouse gas emissions attributable to the generation of energy, including, but not limited to, reporting, registering, tracking, allocating for or accounting for such emissions. Promptly following Buyer's written request, Seller agrees to take all commercially reasonable actions and execute or provide any and all documents, information or instruments with respect to generation by the Facility reasonably necessary to permit Buyer to comply with such requirements, if any.

6. INDEMNITY

Each Party as indemnitor shall save harmless and indemnify the other Party and the directors, officers, and employees of such other Party against and from any and all loss and liability for injuries to persons including employees of either Party, and damages, including property of either Party, resulting from or arising out of: (a) the engineering, design, construction, maintenance, or operation of; or (b) the installation of replacements, additions, or betterments to the indemnitor's facilities. This indemnity and save harmless provision shall apply notwithstanding the active or passive negligence of the indemnitee. Neither Party shall be indemnified for liability or loss, resulting from its sole negligence or willful misconduct. The indemnitor shall, on the other Party's request, defend any suit asserting a

claim covered by this indemnity and shall pay all costs, including reasonable attorney fees that may be incurred by the other Party in enforcing this indemnity.

7. LIMITATION OF DAMAGES

EXCEPT AS OTHERWISE PROVIDED IN THIS AGREEMENT THERE IS NO WARRANTY OF MERCHANTABILITY OR FITNESS FOR A PARTICULAR PURPOSE, AND ANY AND ALL IMPLIED WARRANTIES ARE DISCLAIMED. LIABILITY SHALL BE LIMITED TO DIRECT ACTUAL DAMAGES ONLY, SUCH DIRECT ACTUAL DAMAGES SHALL BE THE SOLE AND EXCLUSIVE REMEDY AND ALL OTHER REMEDIES OR DAMAGES AT LAW OR IN EQUITY ARE WAIVED UNLESS EXPRESSLY HEREIN PROVIDED. NEITHER PARTY SHALL BE LIABLE FOR CONSEQUENTIAL, INCIDENTAL, PUNITIVE, EXEMPLARY OR INDIRECT DAMAGES, LOST PROFITS OR OTHER BUSINESS INTERRUPTION DAMAGES, BY STATUTE, IN TORT OR CONTRACT, UNDER ANY INDEMNITY PROVISION OR OTHERWISE. UNLESS EXPRESSLY HEREIN PROVIDED, AND SUBJECT TO THE PROVISIONS OF SECTION 6 (INDEMNITY), IT IS THE INTENT OF THE PARTIES THAT THE LIMITATIONS HEREIN IMPOSED ON REMEDIES AND THE MEASURE OF DAMAGES BE WITHOUT REGARD TO THE CAUSE OR CAUSES RELATED THERETO, INCLUDING THE NEGLIGENCE OF ANY PARTY, WHETHER SUCH NEGLIGENCE BE SOLE, JOINT OR CONCURRENT, OR ACTIVE OR PASSIVE.

8. NOTICES

Notices shall, unless otherwise specified herein, be in writing and may be delivered by hand delivery, United States mail, overnight courier service, facsimile or electronic messaging (e-mail). Whenever this Agreement requires or permits delivery of a "notice" (or requires a Party to "notify"), the Party with such right or obligation shall provide a written communication in the manner specified below. A notice sent by facsimile transmission or e-mail will be recognized and shall be deemed received on the Business Day on which such notice was transmitted if received before 5 p.m. Pacific prevailing time (and if received after 5 p.m., on the next Business Day) and a notice by overnight mail or courier shall be deemed to have been received two (2) Business Days after it was sent or such earlier time as is confirmed by the receiving Party unless it confirms a prior oral communication, in which case any such notice shall be deemed received on the day sent. A Party may change its addresses by providing notice of same in accordance with this provision. All written notices shall be directed as follows:

TO PG&E: Pacific Gas and Electric Company
Attention: Manager, Contract Management
245 Market Street, Mail Code N12E
San Francisco, CA 94177-0001

TO SELLER: Pristine Sun LLC
4695 MacArthur Court,
11th Floor, Newport Beach,
CA 92660

9. INSURANCE

9.1 General Liability Coverage.

9.1.1 Seller shall maintain during the performance hereof, General Liability Insurance² of not less than \$1,000,000 if the Facility's Nameplate is over 100 kW, \$500,000 if the Facility's Nameplate is over 20 kW to 100kW or \$100,000 if the Facility's Nameplate is 20 kW or below of combined single limit or equivalent for bodily injury, personal injury, and property damage as the result of any one occurrence.

9.1.2 General Liability Insurance shall include coverage for Premises-Operations, Owners and Contractors Protective, Products/Completed Operations Hazard, Explosion, Collapse, Underground, Contractual Liability, and Broad Form Property Damage including Completed Operations.

9.1.3 Such insurance shall provide for thirty (30) days written notice to PG&E prior to cancellation, termination, alteration, or material change of such insurance.

9.2 Additional Insurance Provisions.

9.2.1 Evidence of coverage described above in Paragraph 9.1 shall state that coverage provided in primary and is not excess to or contributing with any insurance or self-insurance maintained by PG&E.

9.2.2 PG&E shall have the right to inspect or obtain a copy of the original policy(ies) of insurance.

9.2.3 Seller shall furnish the required certificates and endorsements to PG&E prior to commencing operation.

9.2.4 All insurance certificates, endorsements, cancellations, terminations, alterations, and material changes of such insurance shall be issued and submitted to the following:

² Governmental agencies which have an established record of self-insurance may provide the required coverage through self-insurance.

Pacific Gas and Electric Company
Attention: Manager, Insurance Department
77 Beale Street, Room E280
San Francisco, CA 94105

10. TERM, DEFAULT, TERMINATION EVENT AND TERMINATION

10.1 Term. The term of this Agreement shall commence upon execution by the duly authorized representatives of each of PG&E and Seller and shall remain in effect until the conclusion of the Delivery Term or unless terminated sooner pursuant to Section 10.3 of this Agreement (the "Term"). All indemnity rights shall survive the termination of this Agreement for twelve (12) months.

10.2 Termination Event. Buyer shall be entitled to terminate the Agreement upon the occurrence of any of the following, each of which is a "Termination Event":

- (a) The Facility has not achieved Commercial Operation within eighteen (18) months of the Execution Date of this Agreement;
- (b) Seller has not sold or delivered the Product from the Facility to PG&E for a period of twelve (12) consecutive months;
- (c) Seller breaches its covenant to maintain its status as an ERR as set forth in Section 4.3.2 of the Agreement.

10.3 Termination.

10.3.1 Declaration of a Termination Event. If a Termination Event has occurred and is continuing, Buyer shall have the right to: (a) send notice, designating a day, no earlier than five (5) days after such notice is deemed to be received (as provided in Section 8) and no later than twenty (20) days after such notice is deemed to be received (as provided in Section 8), as an early termination date of this Agreement ("Early Termination Date") unless Seller has timely communicated with Buyer and the Parties have agreed to resolve the circumstances giving rise to the Termination Event; (b) accelerate all amounts owing between the Parties; and (c) terminate this Agreement and end the Delivery Term effective as of the Early Termination Date.

10.3.2 Release of Liability for Termination Event. Upon termination of this Agreement pursuant to Section 10.3.1, neither Party shall be under any further obligation or subject to liability hereunder, except with respect to the indemnity provision in Section 6 hereof, which shall remain in effect for a period of twelve (12) months following the Early Termination Date.

11. SCHEDULING

11.1 Scheduling Obligations. PG&E shall be Seller's designated Scheduling Coordinator (as defined by CAISO Tariff). PG&E will schedule Seller's project using Prudent Utility Practices and Seller shall employ Prudent Utility Practices and exercise reasonable efforts to operate and maintain its project. All generation interconnection and scheduling services shall be performed in accordance with all applicable operating policies, criteria, guidelines and tariffs of the CAISO or its successor, and any other generally accepted operational requirements. Seller, at its own expense, shall be responsible for complying with all applicable contractual, metering and interconnection requirements. Seller shall promptly notify PG&E of significant (i.e., greater than 100 kW) changes to its energy schedules using PG&E's web site (see Appendix D). Seller will exercise reasonable efforts to comply with conditions that might arise if the CAISO modifies or amends its tariffs, standards, requirements, and/or protocols in the future.

11.2 CAISO Charges.

11.2.1 CAISO Charge Obligations. PG&E and Seller shall cooperate to minimize CAISO delivery imbalances and any resulting fees, liabilities, assessments or similar charges assessed by the CAISO ("CAISO Charges") to the extent possible, and shall each promptly notify the other as soon as possible of any material loss of system capability, deviation or imbalance that is occurring or has occurred. Seller shall reimburse PG&E for any CAISO Charges that PG&E incurs as a result of Seller's loss of system capability, deviation, or imbalance. Any such CAISO Charges reimbursable to PG&E shall be limited to the period until the commencement of the next settlement period following Seller's notification for which the delivery schedule can be adjusted. Notwithstanding anything to the contrary herein, in the event Seller makes a change to its schedule on the actual date and time of delivery for any reason (other than an adjustment imposed by CAISO) which results in differences between the project's actual generation and the scheduled generation (whether in part or in whole), Seller shall use reasonable efforts to notify PG&E. PG&E will make commercially reasonable efforts to accommodate Seller's changes and mitigate any imbalance penalties or charges levied for such changes.

11.2.2 CAISO Penalties. Seller shall be responsible for any "non-Performance Penalties" assessed to PG&E by the CAISO ("CAISO Penalties"), under the CAISO Tariff Enforcement Protocol, and not due to any fault of PG&E, which shall include, without limitation, any deviation, imbalance or uninstructed energy charges or penalties payable to the CAISO that are due to the fault of Seller. To the extent that Seller materially deviates from its energy schedules (other than an adjustment imposed by the CAISO, a deviation due to any fault of PG&E, or an excused Seller failure to deliver, whether for reasons of Force Majeure or otherwise), and such departure results in CAISO Penalties being assessed to PG&E, such CAISO Penalties shall be passed on to Seller. Any such CAISO Penalties passed on to Seller shall be limited to the period until the commencement of the next settlement period following Seller's notification (as described above) for which the delivery schedule can be adjusted.

12. CONFIDENTIALITY

Seller authorizes PG&E to release to the CEC and/or the CPUC information regarding the Facility, including the Seller's name and location, and the size, location and operational characteristics of the Facility, the Term, the ERR type, the Initial Energy Delivery Date and the net power rating of the Facility, as requested from time to time pursuant to the CEC's or CPUC's rules and regulations.

13. ASSIGNMENT

Neither Party shall assign this Agreement or its rights hereunder without the prior written consent of the other Party, which consent shall not be unreasonably withheld; provided, however, either Party may, without the consent of the other Party (and without relieving itself from liability hereunder), transfer, sell, pledge, encumber or assign this Agreement or the accounts, revenues or proceeds hereof to its financing providers and the financing provider(s) shall assume the payment and performance obligations provided under this Agreement with respect to the transferring Party provided, however, that in each such case, any such assignee shall agree in writing to be bound by the terms and conditions hereof and so long as the transferring Party delivers such tax and enforceability assurance as the non-transferring Party may reasonably request.

14. GOVERNING LAW

This agreement and the rights and duties of the parties hereunder shall be governed by and construed, enforced and performed in accordance with the laws of the state of California, without regard to principles of conflicts of law. To the extent enforceable at such time, each party waives its respective right to any jury trial with respect to any litigation arising under or in connection with this agreement.

15. SEVERABILITY

If any provision in this Agreement is determined to be invalid, void or unenforceable by the CPUC or any court having jurisdiction, such determination shall not invalidate, void, or make unenforceable any other provision, agreement or covenant of this Agreement and the Parties shall use their best efforts to modify this Agreement to give effect to the original intention of the Parties.

16. COUNTERPARTS

This Agreement may be executed in one or more counterparts each of which shall be deemed an original and all of which shall be deemed one and the same Agreement. Delivery of an executed counterpart of this Agreement by facsimile or PDF transmission will be deemed as effective as delivery of an originally executed counterpart. Each Party delivering an executed counterpart of this Agreement by facsimile or PDF transmission will also deliver

an originally executed counterpart, but the failure of any Party to deliver an originally executed counterpart of this Agreement will not affect the validity or effectiveness of this Agreement.

17. GENERAL

The CPUC has reviewed and approved this Agreement. No amendment to or modification of this Agreement shall be enforceable unless reduced to writing and executed by both parties. This Agreement shall not impart any rights enforceable by any third party other than a permitted successor or assignee bound to this Agreement. Waiver by a Party of any default by the other Party shall not be construed as a waiver of any other default. The term "including" when used in this Agreement shall be by way of example only and shall not be considered in any way to be in limitation. The headings used herein are for convenience and reference purposes only.

IN WITNESS WHEREOF, each Party has caused this Agreement to be duly executed by its authorized representative as of the date of last signature provided below.

PACIFIC GAS AND ELECTRIC COMPANY

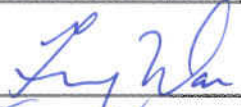
By:  Date: 8/31/2011
Name: Fong Wan
Title: Senior VP, Energy Procurement

SELLER

By:  Date: 7-19-2011
Name: Troy Helming
Title: Principal of Pristine Sun LLC

Appendix A
DEFINITIONS

“Business Day” means any day except a Saturday, Sunday, or a Federal Reserve Bank holiday during the hours of 8:00 a.m. and 5:00 p.m. local time for the relevant Party’s principal place of business where the relevant Party in each instance shall be the Party from whom the notice, payment or delivery is being sent.

“CAISO” means the California Independent System Operator Corporation or any successor entity performing similar functions.

“CAISO Tariff” means the CAISO FERC Electric Tariff, Fifth Replacement Volume No. 1, as amended from time to time.

“California Renewables Portfolio Standard” means the renewable energy program and policies codified in California Public Utilities Code Sections 399.11 through 399.20 and California Public Resources Code Sections 25740 through 25751, as such provisions may be amended or supplemented from time to time.

“CEC” means the California Energy Commission or its successor agency.

“Commercial Operation Date” means the date on which the Facility is operating and is in compliance with applicable interconnection and system protection requirements, and able to produce and deliver energy to PG&E pursuant to the terms of this Agreement.

“Contract Year” means a period of twelve (12) consecutive months with the first Contract Year commencing on the first day of the month immediately following the Initial Energy Delivery Date and each subsequent Contract Year commencing on the anniversary of the Initial Energy Delivery Date.

“CPUC” means the California Public Utilities Commission, or successor entity.

“Delivery Point” means the point of interconnection to the PG&E distribution or transmission system.

“Dispatch Down Period” means: (a) curtailments ordered by the CAISO or PG&E as a result of a System Emergency, as defined in the CAISO Tariff; or (b) scheduled or unscheduled maintenance on PG&E’s transmission, distribution or interconnection facilities that prevents Buyer from receiving Delivered Energy at the Delivery Point. Notwithstanding the foregoing sentence, Buyer shall have the option in its sole discretion to curtail Seller’s energy deliveries up to fifty (50) hours each calendar year.

“Eligible Renewable Energy Resource” or “ERR” has the meaning set forth in Public Utilities Code Sections 399.12 and California Public Resources Code Section 25741, as either code provision may be amended or supplemented from time to time.

“Execution Date” means the latest signature date found at the end of the Agreement.

“FERC” means the Federal Energy Regulatory Commission or any successor government agency.

“Forced Outage” means any unplanned reduction or suspension of the electrical output from the Facility resulting in the unavailability of the Facility, in whole or in part, in response to a mechanical, electrical, or hydraulic control system trip or operator-initiated trip in response to an alarm or equipment malfunction and any other unavailability of the Facility for operation, in whole or in part, for maintenance or repair that is not a scheduled maintenance outage and not the result of Force Majeure.

“Force Majeure” means any event or circumstance which wholly or partly prevents or delays the performance of any material obligation arising under this Agreement, but only if and to the extent (i) such event is not within the reasonable control, directly or indirectly, of the Party seeking to have its performance obligation(s) excused thereby, (ii) the Party seeking to have its performance obligation(s) excused thereby has taken all reasonable precautions and measures to prevent or avoid such event or mitigate the effect of such event on such Party’s ability to perform its obligations under this Agreement and which by the exercise of due diligence such Party could not reasonably have been expected to avoid and which by the exercise of due diligence it has been unable to overcome, and (iii) such event is not the direct or indirect result of the negligence or the failure of, or caused by, the Party seeking to have its performance obligations excused thereby. Force Majeure shall not be based on: (i) PG&E’s inability economically to use or resell the energy or capacity purchased hereunder; (ii) Seller’s ability to sell the energy, capacity or other benefits produced by or associated with the Facility at a price greater than the price set forth in this Agreement, (iii) Seller’s inability to obtain approvals of any type for the construction, operation, or maintenance of the Facility; (iv) Seller’s inability to obtain sufficient fuel to operate the Facility, except if Seller’s inability to obtain sufficient fuel is caused by an event of Force Majeure of the specific type described in any of subsections (i) through (iv) of this definition of Force Majeure; (v) a Forced Outage except where such Forced Outage is caused by an event of Force Majeure of the specific type described in any of subsections (i) through (iv) of this definition of Force Majeure; (vi) a strike or labor dispute limited only to Seller, Seller’s affiliates, the Engineering, Procurement, and Construction Contractor or subcontractors thereof; or (vii) any equipment failure not caused by an event of Force Majeure of the specific type described in any of subsections (i) through (iv) of this definition of Force Majeure.

“Green Attributes” means any and all credits, benefits, emissions reductions, offsets, and allowances, howsoever entitled, attributable to the generation from the Project, and its avoided emission of pollutants. Green Attributes include but are not limited to Renewable Energy Credits, as well as: (1) any avoided emission of pollutants to the air, soil or water such as sulfur oxides (SO_x), nitrogen oxides (NO_x), carbon monoxide (CO) and other pollutants; (2) any avoided emissions of carbon dioxide (CO₂), methane (CH₄), nitrous oxide, hydrofluorocarbons, perfluorocarbons, sulfur hexafluoride and other greenhouse gases (GHGs) that have been determined by the United Nations Intergovernmental Panel on

Climate Change, or otherwise by law, to contribute to the actual or potential threat of altering the Earth's climate by trapping heat in the atmosphere;² (3) the reporting rights to these avoided emissions, such as Green Tag Reporting Rights. Green Tag Reporting Rights are the right of a Green Tag Purchaser to report the ownership of accumulated Green Tags in compliance with federal or state law, if applicable, and to a federal or state agency or any other party at the Green Tag Purchaser's discretion, and include without limitation those Green Tag Reporting Rights accruing under Section 1605(b) of The Energy Policy Act of 1992 and any present or future federal, state, or local law, regulation or bill, and international or foreign emissions trading program. Green Tags are accumulated on a MWh basis and one Green Tag represents the Green Attributes associated with one (1) MWh of Energy. Green Attributes do not include (i) any energy, capacity, reliability or other power attributes from the Project, (ii) production tax credits associated with the construction or operation of the Project and other financial incentives in the form of credits, reductions, or allowances associated with the project that are applicable to a state or federal income taxation obligation, (iii) fuel-related subsidies or "tipping fees" that may be paid to Seller to accept certain fuels, or local subsidies received by the generator for the destruction of particular preexisting pollutants or the promotion of local environmental benefits, or (iv) emission reduction credits encumbered or used by the Project for compliance with local, state, or federal operating and/or air quality permits. If the Project is a biomass or biogas facility and Seller receives any tradable Green Attributes based on the greenhouse gas reduction benefits or other emission offsets attributed to its fuel usage, it shall provide Buyer with sufficient Green Attributes to ensure that there are zero net emissions associated with the production of electricity from the Project.

"Law" means any statute, law, treaty, rule, regulation, ordinance, code, permit, enactment, injunction, order, writ, decision, authorization, judgment, decree or other legal or regulatory determination or restriction by a court or Governmental Authority of competent jurisdiction, including any of the foregoing that are enacted, amended, or issued after the Execution Date, and which becomes effective during the Delivery Term; or any binding interpretation of the foregoing.

"Market Price Referent" means the market price referent applicable to this Agreement, as determined by the CPUC in accordance with Public Utilities Code Section 399.15(c), as may be amended or modified from time to time.

"Nameplate" has the meaning set forth in Section 2.1.4.

"Product" means the energy (net of Station Use), capacity and all ancillary products, services or attributes similar to the foregoing which are or can be produced by or associated with the Facility, including, without limitation, renewable attributes, Renewable Energy Credits, Resource Adequacy Benefits and Green Attributes.

² Avoided emissions may or may not have any value for GHG compliance purposes. Although avoided emissions are included in the list of Green Attributes, this inclusion does not create any right to use those avoided emissions to comply with any GHG regulatory program.

“Renewable Energy Credit” has the meaning set forth in Public Utilities Code Section 399.12(f), as may be amended from time to time or as further defined or supplemented by Law.

“Resource Adequacy Benefits” means the rights and privileges attached to the Facility that satisfy any entity’s resource adequacy obligations, as those obligations are set forth in any Resource Adequacy Rulings and shall include any local, zonal or otherwise locational attributes associated with the Facility.

“Resource Adequacy Rulings” means CPUC Decisions 04-01-050, 04-10-035, 05-10-042, 06-06-064, 06-07-031 and any subsequent CPUC ruling or decision, or any other resource adequacy laws, rules or regulations enacted, adopted or promulgated by any applicable governmental authority, as such decisions, rulings, laws, rules or regulations may be amended or modified from time-to-time during the Delivery Term.

“Station Use” means energy consumed within the Facility’s electric energy distribution system as losses, as well as energy used to operate the Facility’s auxiliary equipment. The auxiliary equipment may include, but is not limited to, forced and induced draft fans, cooling towers, boiler feeds pumps, lubricating oil systems, plant lighting, fuel handling systems, control systems, and sump pumps.

“WREGIS” means the Western Renewable Energy Generating Information System or any successor renewable energy tracking program.

“WREGIS Certificate Deficit” has the meaning set forth in Section 3.2.1.

Appendix B

INITIAL ENERGY DELIVERY DATE CONFIRMATION LETTER

In accordance with the terms of that certain Small Renewable Generator Power Purchase Agreement dated _____ ("Agreement") by and between Pacific Gas and Electric Company ("PG&E") and Pristine Sun LLC ("Seller"), this letter serves to document the parties further agreement that (i) the conditions precedent to the occurrence of the Initial Energy Delivery Date have been satisfied, and (ii) Seller has scheduled and PG&E has received the energy, as specified in the Agreement, as of this _____ day of _____, _____. This letter shall confirm the Initial Energy Delivery Date, as defined in the Agreement, as the date referenced in the preceding sentence.

IN WITNESS WHEREOF, each Party has caused this Agreement to be duly executed by its authorized representative as of the date of last signature provided below:

By:

By: Pacific Gas and Electric Company

Signed: 

Signed: _____

Name: Troy Helming

Name: _____

Title: Principal of Pristine Sun LLC

Title: _____

Date: 07/19/2011

Date: _____

Appendix C
Time of Delivery (TOD) Periods & Factors

Monthly Period	Super-Peak ¹	Shoulder ²	Night ³
Jun – Sep	2.38	1.12	0.59
Oct. - Dec., Jan. & Feb.	1.10	.94	0.66
Mar. – May	1.22	0.90	0.61

Definitions:

1. Super-Peak (5x8) = HE (Hours Ending) 13 – 20 (Pacific Prevailing Time (PPT)), Monday - Friday (*except* NERC holidays) in the applicable Monthly Period.
2. Shoulder = HE 7 - 12, 21 and 22 PPT Monday - Friday (*except* NERC holidays); and HE 7 - 22 PPT Saturday, Sunday and *all* NERC holidays in the applicable Monthly Period.
3. Night (7x8) = HE 1 - 6, 23 and 24 PPT all days (*including* NERC holidays) in the applicable Monthly Period.

“NERC Holidays” mean the following holidays: New Year’s Day, Memorial Day, Independence Day, Labor Day, Thanksgiving Day, and Christmas Day. Three of these days, Memorial Day, Labor Day, and Thanksgiving Day occur on the same day each year. Memorial Day is the last Monday in May; Labor Day is the first Monday in September; and Thanksgiving Day is the 4th Thursday in November. New Year’s Day, Independence Day, and Christmas Day, by definition, are predetermined dates each year. However, in the event they occur on a Sunday, the “NERC Holiday” is celebrated on the Monday immediately following that Sunday. However, if any of these days occur on a Saturday, the “NERC Holiday” remains on that Saturday.

Appendix D

COUNTERPARTY NOTIFICATION AND FORECASTING REQUIREMENTS

A. NOTIFICATION REQUIREMENTS FOR START-UP AND SHUTDOWN

Prior to paralleling to or after disconnecting from the electric system, ALWAYS notify your designated Distribution Operator as follows:

1. Call your Distribution Operator for permission to parallel before any start-up.
2. Call your Distribution Operator again after start-up with parallel time.
3. Call your Distribution Operator after any separation and report separation time as well as date and time estimate for return to service.

B. FORECASTING REQUIREMENTS

1. Seller shall abide with all established requirements and procedures described below:
 - (a) Generating Facilities 1000 kW and greater must comply with the CAISO Tariff and Protocols while generating facilities under 1000 kW must comply with all applicable interconnection, communication and metering rules; and
 - (b) Generating Facilities 100 kW and greater must provide a weekly forecast of their expected generation output.
2. Weekly Energy Forecasting Procedures.

Seller must meet all of the following requirements specified below:

Beginning the Wednesday prior to the planned Initial Energy Delivery Date of the Generating Facility, and every Wednesday thereafter, Seller will electronically provide PG&E with an Energy Forecast for the next calendar week, by no later than 5 PM Wednesday of the week preceding the week covered by the Energy Forecast.

The Weekly Energy Forecast submitted to PG&E shall:

- a) Not include any anticipated or expected electric energy losses;
- b) Be submitted using PG&E's website at <https://www.pge.com/qic>, or as otherwise instructed by PG&E;
- c) Include Seller's contact information;

d) Limit Day Ahead forecast changes to no less than 100 kW.

3. Outage and Scheduled Maintenance Reporting Procedures.

Submit outage information by posting on PG&E's website at <https://www.pge.com/qic> . If the website is unavailable, implement the procedures set forth below:

For project outages, complete the specifics below and submit by email to DAenergy@pge.com and Bilat_Settlements@pge.com

Email subject Field: dd/mm/yyyy – dd/mm/yyyy XYZ Company Project #2 Outage Notification

Email body:

Type of Outage: Planned Outage, Forced Outage, Prolonged Outage
Start Date and Start Time
Estimated or Actual End Date and End Time
Date and time when reported to PG&E and name(s) of PG&E representative(s) contacted.

C. CHANGES TO OPERATING PROCEDURES.

Seller understands and acknowledges that the requirements of Appendix D are subject to change by Buyer from time to time and, upon receipt of Notice of any such changes, Seller agrees to work in good faith to implement any such changes as reasonably deemed necessary by Buyer; provided that such change does not result in an increase cost of performance to Seller other than de minimis amounts.

Appendix E

Attach a description of the Facility, including a summary of its significant components, a drawing showing the general arrangements of the Facility, and a single line diagram illustrating the interconnection of the Facility and loads with PG&E's electric distribution or transmission system.



Land Information:

Land: Flat Acres required: 10.00 Size: 1.000 mW

Longitude: -120.713454, Latitude: 35.645280

Total # of Results:1

Result #1: PASO ROBLES 1104

From layer: **Distribution Lines**

Substation Name	PASO ROBLES
Substation Number	18261
Feeder Number	182611104
Nominal Circuit Voltage (kv)	12
Circuit Capacity (MW)	12.19
Circuit Projected Peak Load (MW)	9.54
Substation Bank	2
Substation Bank Capacity (MW)	30
Substation Bank Peak Load (MW)	12
Existing Distributed Generation (MW)	0.2701
Queued Distributed Generation (MW)	0

Property Details

Owner: [REDACTED]

Property Address:

910 Nacimiento Lake Drive
Paso Robles, CA 93466

County Name:

San Luis Obispo

Parcel Number:

026 271 028

Assessor Legal Description:

pm 54-51 Par 1 T265 R12E PTN SEC 19 SFR 40-80 AC



POWER STATION 1 MW (SOLARON 2 X 500KW INVERTER), 600 VDC PV ARRAYS MODULES-AUO PM240P00, 240W

ONE LINE DRAWING - NOT TO SCALE

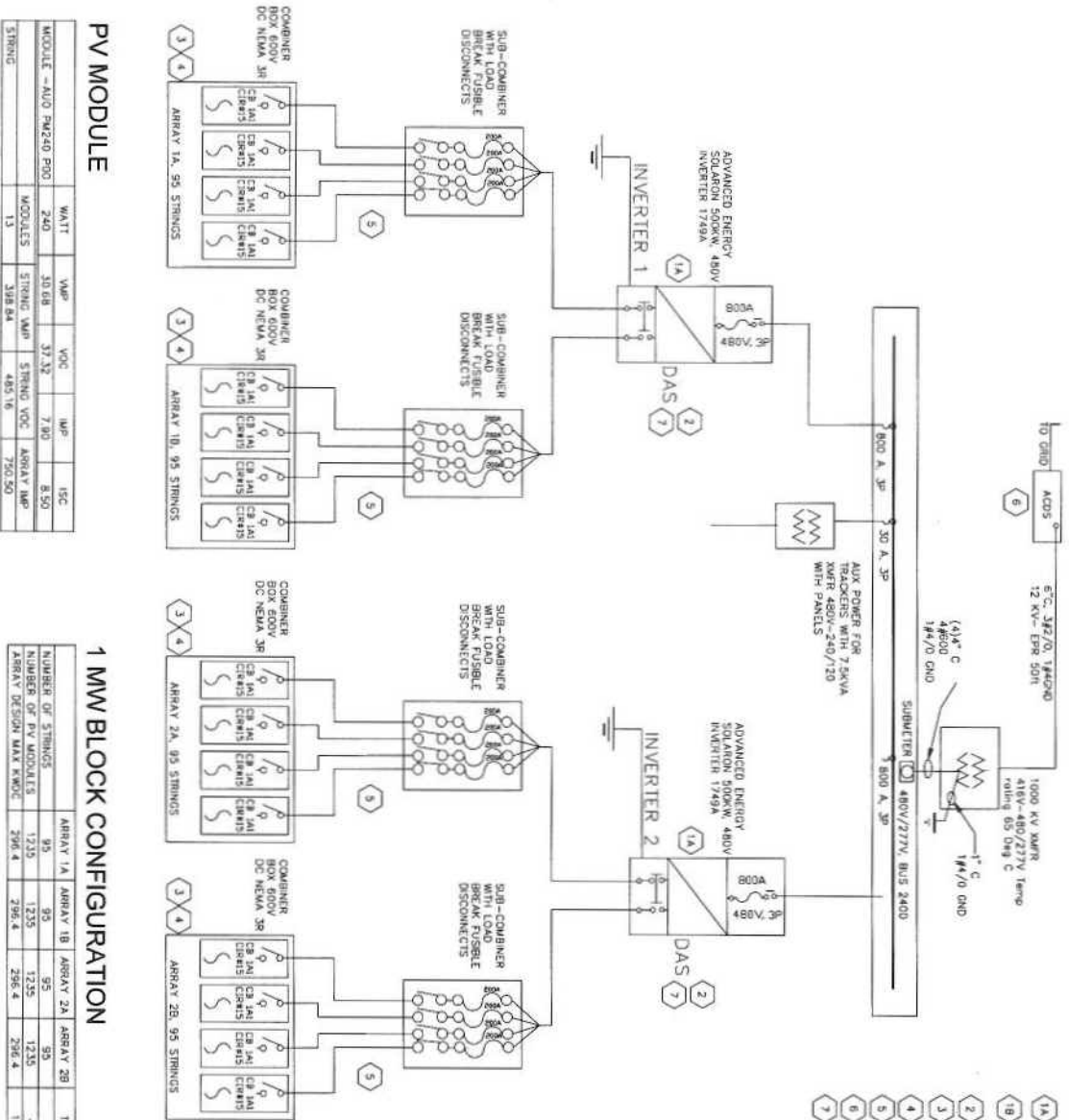

LEGEND

- 1A ADVANCED ENERGY SOLARON 500KW, 480V INVERTER 1749A UL 1741
- 1B ADVANCED ENERGY SOLARON 500KW, 480V INVERTER 1749A UL 1741
- 2 OVER/VOLTER FREQUENCY & VOLTAGE DETECTION, GND FAULT PROTECTION PROVIDED
- 3 600VDC RATED COMBINER WITH 15 INPUTS, 15A FUSIBLE 3120KWHDC
- 4 12KV MODULES CONNECTED IN SERIES TO PROVIDE TOTAL VOLTAGE FOR DC WAYS NOT DROP MORE THAN 2%
- 5 OUTDOOR 12KV AC DISCONNECT SWITCH VISIBLE NEMA 3R DATA ACQUISITION SYSTEM WILL PROVIDE MONITORING, ALARMING, LOGGING AND DATA ARCHIVING
- 6 600VDC RATED COMBINER WITH 15 INPUTS, 15A FUSIBLE 3120KWHDC
- 7 ALARMING, LOGGING AND DATA ARCHIVING

PV MODULE

MODULE -AUO PM240 P00	WATT	VMP	VOC	IMP	ISC
240	240	30.68	37.32	7.90	8.50
MODULES	13	398.94	485.16		750.50
STRING					

1 MW BLOCK CONFIGURATION

NUMBER OF STRINGS	ARRAY 1A	ARRAY 1B	ARRAY 2A	ARRAY 2B	TOTAL
95	95	1235	95	300	4840
NUMBER OF PV MODULES	296.4	296.4	296.4	296.4	1185.6
ARRAY DESIGN MAX KWDC					

<p>2056-Jardine</p> <p>910 Nacimiento Lake Drive, Paso Robles, CA 93446</p>	<p>PROJECT TITLE</p> <p>1000 KW AC PV Photovoltaic On Grid System</p>	<p>COMPANY</p> <p>Pristine Sun LLC 4695 MacArthur Court Newport Beach, CA 92660 Engineering:307-200-7075</p>
<p>SHEET TITLE</p> <p>SINGLE LINE DIAGRAM</p>	<p>DATE OF THE STATION</p> <p>1000 KW</p> <p>INVERTER OUTPUT (2) 500KW</p>	<p>POWER</p> <p>240 W</p> <p>DATE: 07/26/2011</p> <p>SCALE: NTS</p> <p>DRAWN: Pristine Sun</p> <p>CHECK:</p> <p>1</p>



