

POWER PURCHASE AGREEMENT

Between

PACIFIC GAS AND ELECTRIC COMPANY
(as “Buyer”)

and

SHILOH IV WIND PROJECT, LLC
(as “Seller”)

POWER PURCHASE AGREEMENT

TABLE OF CONTENTS

PREAMBLE

GENERAL TERMS AND CONDITIONS

ARTICLE ONE: GENERAL DEFINITIONS	1
ARTICLE TWO: GOVERNING TERMS AND TERM	18
2.1 Entire Agreement	18
2.2 Interpretation	18
2.3 Authorized Representatives.....	19
2.4 Separation of Functions.....	19
2.5 Conditions Precedent.....	19
2.6 Term	20
2.7 Binding Nature	20
ARTICLE THREE: OBLIGATIONS AND DELIVERIES.....	21
3.1 Seller’s and Buyer’s Obligations.....	21
3.2 Green Attributes	28
3.3 Resource Adequacy	29
3.4 Transmission and Scheduling.....	29
3.5 Standards of Care	33
3.6 Metering	33
3.7 Outage Notification	34
3.8 Operations Logs and Access Rights	35
3.9 New Generation Facility	35
ARTICLE FOUR: COMPENSATION; MONTHLY PAYMENTS.....	38
4.1 Price.....	38
4.2 [Intentionally omitted].....	39
4.3 [Intentionally omitted].....	39
4.4 Excess Delivered and Deemed Delivered Energy.....	39
4.5 CAISO Charges.....	39
4.6 Test Period Payments	40
4.7 Additional Compensation.....	40
ARTICLE FIVE: EVENTS OF DEFAULT; PERFORMANCE REQUIREMENT; REMEDIES	40
5.1 Events of Default.....	40
5.2 Declaration of Early Termination Date	42
5.3 Calculation of Termination Payment	42
5.4 Notice of Payment of Termination Payment	43
5.5 Disputes With Respect to Termination Payment.....	43
5.6 Rights And Remedies Are Cumulative	43

5.7	Duty to Mitigate	43
5.8	Damage Payment for Failure to Achieve Guaranteed Dates	43
ARTICLE SIX: PAYMENT		43
6.1	Billing and Payment; Remedies	43
6.2	Disputes and Adjustments of Invoices	44
ARTICLE SEVEN: LIMITATIONS		44
7.1	Limitation of Remedies, Liability and Damages.....	44
ARTICLE EIGHT: CREDIT AND COLLATERAL REQUIREMENTS		45
8.1	Buyer Financial Information	45
8.2	Seller Financial Information.....	45
8.3	Grant of Security Interest/Remedies	45
8.4	Performance Assurance.....	46
8.5	Letter of Credit.....	47
ARTICLE NINE: GOVERNMENTAL CHARGES		48
9.1	Cooperation	48
9.2	Governmental Charges.....	48
ARTICLE TEN: MISCELLANEOUS		48
10.1	Recording	48
10.2	Representations and Warranties	49
10.3	Covenants	51
10.4	Title and Risk of Loss	51
10.5	Indemnities	51
10.6	Assignment.....	52
10.7	Confidentiality.....	53
10.8	RPS Confidentiality.....	54
10.9	Audit.....	54
10.10	Insurance	54
10.11	Access to Financial Information.....	58
10.12	Governing Law.....	58
10.13	General	58
10.14	Severability.....	59
10.15	Counterparts	59
10.16	Discussions Concerning Buyer Purchase of Project	59
ARTICLE ELEVEN: TERMINATION EVENTS.....		59
11.1	[Intentionally omitted].....	59
11.2	Force Majeure Termination Event	59
ARTICLE TWELVE: DISPUTE RESOLUTION		61
12.1	Intent of the Parties	61
12.2	Management Negotiations.....	61
12.3	Mediation	62
12.4	Arbitration	62

ARTICLE THIRTEEN: NOTICES..... 63

SIGNATURES 64

APPENDICES

The following Appendices constitute a part of this Agreement and are incorporated into this Agreement by reference:

Appendix I Form of Letter of Credit

Appendix II Initial Energy Delivery Date Confirmation Letter

Appendix III Milestones Schedule

Attachment A Form of Monthly Progress Report

Appendix IV Project Description Including Description of Site

Appendix V Delivery Term Contract Quantity Schedule

Appendix VI Construction Start and Commercial Operation Certification Forms and Procedures

 Appendix VI-1 Construction Start Form of Certification

 Appendix VI-2 Commercial Operation Certification Procedure

Attachment A Commercial Operation Form of Certification

Appendix VII GEP Damages Calculation

Appendix VIII Notification Requirements for Available Capacity and Project Outages

Appendix IX Certification of Third Party Agreement

Appendix X Resource Adequacy

Appendix XI Notices List

Appendix XII Form of Consent to Assignment

Appendix XIII Seller Documentation Condition Precedent

Appendix XIV Form of Actual Availability Report

 Attachment A Form of Actual Availability Report

Appendix XV Telemetry Parameters for Wind or Solar Facility

Appendix XVI Buyer Curtailment Orders

Appendix XVII Form of Letter of Concurrence

Appendix XVIII Supplier Diversity Program

Appendix XIX enXco QF Agreement

Appendix XX Form of Contract Capacity Reduction Notice

POWER PURCHASE AGREEMENT

PREAMBLE

This Power Purchase Agreement, together with the appendices and any other attachments referenced herein, is made and entered into between Pacific Gas and Electric Company, a California corporation (“Buyer” or “PG&E”), and Shiloh IV Wind Project, LLC, a Delaware limited liability company (“Seller”), as of the Execution Date set forth on the signature page hereof. Buyer and Seller hereby agree to the following:

GENERAL TERMS AND CONDITIONS

ARTICLE ONE: GENERAL DEFINITIONS

- 1.1 “Actual Availability Report” has the meaning set forth in Section 3.1(l)(i)
- 1.2 “Affiliate” means, with respect to any person or entity, any other person or entity (other than an individual) that (a) directly or indirectly, through one or more intermediaries, controls, or is controlled by such person or entity or (b) is under common control with such person or entity. For this purpose, “control” means the direct or indirect ownership of fifty percent (50%) or more of the outstanding capital stock or other equity interests having ordinary voting power.
- 1.3 “Agreement” means this Power Purchase Agreement between Buyer and Seller, which is comprised of the Preamble, these General Terms and Conditions, and all appendices, schedules and any written supplements attached hereto and incorporated herein by references, as well as all written and signed amendments and modifications thereto. For purposes of Section 10.12, the word “agreement” shall have the meaning set forth in this definition. For the purposes of Section 3.1(k)(viii), the word “contract” shall have the meaning set forth in this definition.
- 1.4 “Arbitration” has the meaning set forth in Section 12.3.
- 1.5 “As-Available Product” means a Product for which, subject to the terms of this Agreement, (a) Seller is obligated to sell and deliver and (b) Buyer is obligated to purchase and receive, the Energy component of the Product from the Project whenever such Energy is capable of being generated from the Project.
- 1.6 “Availability Standards” means the program set forth in Section 40.9 of the CAISO Tariff, as it may be amended, supplemented or replaced (in whole or in part) from time to time, setting forth certain standards regarding the desired level of availability for Resource Adequacy resources and possible charges and incentive payments for performance thereunder.
- 1.7 “Availability Workbook” has the meaning set forth in Appendix XIV.
- 1.8 “Available Capacity” means the capacity from the Project, expressed in whole megawatts, that is available to generate Product.
- 1.9 “Available Hours” has the meaning set forth in Appendix XIV.
- 1.10 “Bankrupt” means with respect to any entity, such entity that (a) files a petition or otherwise commences, authorizes or acquiesces in the commencement of a proceeding or cause

of action under any bankruptcy, insolvency, reorganization or similar Law, or has any such petition filed or commenced against it and such case filed against it is not dismissed in ninety (90) days, (b) makes an assignment or any general arrangement for the benefit of creditors, (c) otherwise becomes bankrupt or insolvent (however evidenced), (d) has a liquidator, administrator, receiver, trustee, conservator or similar official appointed with respect to it or any substantial portion of its property or assets, or (e) is generally unable to pay its debts as they fall due.

1.11 “Business Day” means any day except a Saturday, Sunday, or a Federal Reserve Bank holiday and shall be between the hours of 8:00 a.m. and 5:00 p.m. local time for the relevant Party’s principal place of business where the relevant Party, in each instance unless otherwise specified, shall be the Party from whom the Notice, payment or delivery is being sent and by whom the Notice or payment or delivery is to be received.

1.12 “Buyer” has the meaning set forth in the Preamble.

1.13 “Buyer Bid Curtailment” means the occurrence of all of the following: (a) the CAISO orders, directs, or provides notice to a Party, which has the effect of requiring the Party to produce less Energy from the Project than capable of being and expected and forecasted to be produced from the Project for the applicable time period; (b) Buyer or Buyer’s SC did not submit a Self-Schedule or Energy Supply Bid for the MWh subject to the reduction, or Buyer or Buyer’s SC submitted an Energy Supply Bid and such Energy Supply Bid resulted in a Schedule that was less than the amount of Energy capable of being and expected and forecasted to be produced by the Project for the same period of time; and (c) no other circumstances exist that constitutes a Force Majeure and/or a Curtailment Period.

1.14 “Buyer Curtailment Order” means the instruction from Buyer to Seller to reduce generation from the Project by the amount, and for the period of time set forth in such order, for reasons unrelated to Force Majeure and/or Curtailment Order.

1.15 “Buyer Curtailment Period” means the period of time during which Seller reduces generation from the Project pursuant to (a) Buyer Bid Curtailment or (b) a Buyer Curtailment Order.

1.16 “Buyer’s Notice” has the meaning set forth in Section 11.2(b)(ii).

1.17 “Buyer’s WREGIS Account” has the meaning set forth in Section 3.1(k)(i).

1.18 “CAISO” means the California Independent System Operator Corporation or any successor entity performing similar functions.

1.19 “CAISO Global Resource ID” means the number or name assigned by the CAISO to the CAISO revenue meter.

1.20 “CAISO Grid” means the system of transmission lines and associated facilities of the Participating Transmission Owners that have been placed under the CAISO’s operational control.

1.21 “CAISO Penalties” means any fees, liabilities, assessments, or similar charges assessed by the CAISO for (a) violation of the CAISO Tariff and all applicable protocols, WECC rules or CAISO operating instructions or orders or (b) as a result of a Party’s failure to follow

Good Utility Practices. In either case “CAISO Penalties” do not include the costs and charges related to Scheduling and imbalances as addressed in Section 4.5(b) of this Agreement.

1.22 “CAISO Revenues” means (a) the credits and other payments received by Buyer, as Seller’s Scheduling Coordinator, as a result of test energy from the Project delivered to the real-time market by Seller during the Test Period, including revenues associated with CAISO dispatches and (b) the debits, costs, penalties and interest that are directly assigned by the CAISO to the CAISO Global Resource ID for the Project for, or attributable to, scheduling and deliveries from the Project under this Agreement.

1.23 “CAISO Tariff” means the California Independent System Operator Corporation, Fifth Replacement FERC Electric Tariff (Open Access Transmission Tariff), as it may be amended, supplemented or replaced (in whole or in part) from time to time.

1.24 “California Renewables Portfolio Standard” means the renewable energy program and policies established by California State Senate Bills 1038 and 1078, codified in California Public Utilities Code Sections 399.11 through 399.20 and California Public Resources Code Sections 25740 through 25751, as such provisions are amended or supplemented from time to time.

1.25 “Capacity Attributes” means any current or future defined characteristic, certificate, tag, credit, or ancillary service attribute, whether general in nature or specific as to the location or any other attribute of the Project, intended to value any aspect of the capacity of the Project to produce Energy or ancillary services, including, but not limited to, any accounting construct so that the full Contract Capacity of the Project may be counted toward a Resource Adequacy Requirement or any other measure by the CPUC, the CAISO, the FERC, or any other entity invested with the authority under federal or state Law, to require Buyer to procure, or to procure at Buyer’s expense, Resource Adequacy or other such products.

1.26 “Capacity Reduction Notice” means a Notice, substantially in the form of Appendix XX attached hereto, incorporating the following: (a) the revised Contract Capacity, which shall not be less than 90 MW, (b) the reduced Contract Quantity, revised solely to reflect the revised Contract Capacity, and (c) the reduced Delivery Term Security, revised on pro rata basis solely to reflect the revised Contract Capacity.

1.27 “CEC” means the California Energy Commission or its successor agency.

1.28 “CEC Certification and Verification” means that the CEC has certified (or, with respect to periods before the Project has been constructed, that the CEC has pre-certified) that the Project is an ERR for purposes of the California Renewables Portfolio Standard and that all Energy produced by the Project qualifies as generation from an ERR for purposes of the Project.

1.29 “Claims” means all third party claims or actions, threatened or filed and, whether groundless, false, fraudulent or otherwise, that directly or indirectly relate to the subject matter of an indemnity, and the resulting losses, damages, expenses, attorneys’ fees and court costs, whether incurred by settlement or otherwise, and whether such claims or actions are threatened or filed prior to or after the termination or expiration of this Agreement.

1.30 “Commercial Operation” means the Project is operating and able to produce and deliver the Product to Buyer pursuant to the terms of this Agreement.

1.31 “Commercial Operation Date” means the date on which Seller (a) notifies Buyer that Commercial Operation has commenced and (b) provides a certification of an authorized officer of Seller, substantially in the form attached hereto as Attachment A to Appendix VI-2, demonstrating satisfactory completion of the Commercial Operation Certification Procedure as provided in Appendix VI-2 hereto.

1.32 “Condition Precedent” means each of, or one of, the conditions set forth in Section 2.4(a)(i) through (v) and “Conditions Precedent” shall refer to all of the conditions set forth in Section 2.4(a)(i) through (v).

1.33 “Construction Cure Period” has the meaning set forth in Section 3.9(c)(iv).

1.34 “Construction Start Date” means the later to occur of the date on which Seller delivers to Buyer (a) a copy of the Notice to Proceed that Seller has delivered to the EPC Contractor for the Project, and (b) a written Certification substantially in the form attached hereto as Appendix VI-1.

1.35 “Contract Capacity” has the meaning set forth in Section 3.1(f).

1.36 “Contract Price” means the price to be paid by Buyer to Seller for the purchase of the Product, as specified in Section 4.1.

1.37 “Contract Quantity” means the quantity of Delivered Energy expected to be delivered by Seller during each Contract Year as set forth in Section 3.1(e)(i) and Appendix V.

1.38 “Contract Year” means a period of twelve (12) consecutive months. The first Contract Year shall commence on the Initial Energy Delivery Date and each subsequent Contract Year shall commence on the anniversary of the Initial Energy Delivery Date.

1.39 “Costs” means, with respect to the Non-Defaulting Party, (a) brokerage fees, commissions and other similar third party transaction costs and expenses reasonably incurred by such Party either in terminating any arrangement pursuant to which it has hedged its obligations or in entering into new arrangements which replace the Terminated Transaction; and (b) all reasonable attorneys’ fees and expenses incurred by the Non-Defaulting Party in connection with the termination of the Transaction.

1.40 “CPUC” or “Commission or successor entity” means the California Public Utilities Commission, or successor entity.

1.41 “CPUC Approval” means a final and non-appealable order of the CPUC, without conditions or modifications unacceptable to the Parties, or either of them, which contains the following terms:

(a) approves this Agreement in its entirety, including payments to be made by the Buyer, subject to CPUC review of the Buyer’s administration of the Agreement; and

(b) finds that any procurement pursuant to this Agreement is procurement from an eligible renewable energy resource for purposes of determining Buyer’s compliance with any obligation that it may have to procure eligible renewable energy resources pursuant to the California Renewables Portfolio Standard (Public Utilities Code Section 399.11 *et seq.*), Decision 03-06-071, or other applicable law.

CPUC Approval will be deemed to have occurred on the date that a CPUC decision containing such findings becomes final and non-appealable.

1.42 “Credit Rating” means, with respect to any entity, the rating then assigned to such entity’s unsecured, senior long-term debt obligations (not supported by third party credit enhancements) or if such entity does not have a rating for its senior unsecured long-term debt, then the rating then assigned to such entity as an issuer rating by S&P or Moody’s. If ratings by S&P and Moody’s are not equivalent, the lower rating shall apply.

1.43 “Cure” has the meaning set forth in Section 8.5(a).

1.44 “Curtailment Order” means any of the following:

(a) the CAISO, Reliability Coordinator, Balancing Authority or any other entity having similar authority or performing similar functions during the Delivery Term, orders, directs, alerts, or provides notice to a Party to curtail Energy deliveries for reasons including, but not limited to, (i) any system emergency, as defined in the CAISO Tariff (“System Emergency”), or (ii) any warning of an anticipated System Emergency, or warning of an imminent condition or situation, which jeopardizes the CAISO’s electric system integrity or the integrity of other systems to which the CAISO is connected;

(b) a curtailment ordered by the Participating Transmission Owner, distribution operator (if interconnected to distribution or sub-transmission system), or any other entity having similar authority or performing similar functions during the Delivery Term, for reasons including, but not limited to, (i) any situation that affects normal function of the electric system including, but not limited to, any abnormal condition that requires action to prevent circumstances such as equipment damage, loss of load, or abnormal voltage conditions, or (ii) any warning, forecast or anticipation of conditions or situations that jeopardize the Participating Transmission Owner’s electric system integrity or the integrity of other systems to which the Participating Transmission Owner is connected;

(c) scheduled or unscheduled maintenance or construction on the Participating Transmission Owner’s or distribution operator’s transmission or distribution facilities that prevents (i) Buyer from receiving or (ii) Seller from delivering Delivered Energy at the Delivery Point; or

(d) a curtailment in accordance with Seller’s obligations under its interconnection agreement with the Participating Transmission Owner or distribution operator.

1.45 “Curtailment Period” means the period of time during which Seller reduces generation from the Project pursuant to a Curtailment Order.

1.46 “Daily Delay Damages” means with respect to a Guaranteed Project Milestone, an amount equal to (a) the Project Development Security Amount posted as of the first date that Daily Delay Damages are payable under this Agreement with respect to such Guaranteed Project Milestone, divided by (b) 120.

1.47 “Damage Payment” means the dollar amount equal to (a) the amount posted as Project Development Security pursuant to Section 8.4(a)(ii) hereof, less (b) amounts collected by Buyer as Daily Delay Damages pursuant to Section 3.9(c)(iv).

- 1.48 “Day-Ahead Availability Notice” has the meaning set forth in Section 3.4(c)(iii)(C).
- 1.49 “Day-Ahead Schedule” has the meaning set forth in the CAISO Tariff.
- 1.50 “Deemed Delivered Energy” means the amount of Energy expressed in MWh that the Project would have produced and delivered to the Delivery Point, but that is not produced by the Project and delivered to the Delivery Point during a Buyer Curtailment Period, which amount shall be the result of the equation provided pursuant to Section 3.1(l)(i)(G) and using relevant Project availability, weather and other pertinent data for the period of time during the Buyer Curtailment Period.
- 1.51 “Deemed Delivered Energy Price” means the price to be paid by Buyer to Seller for Deemed Delivered Energy, as specified in Section 4.1(b).
- 1.52 “Defaulting Party” means the Party that is subject to an Event of Default.
- 1.53 “Deficient Month” has the meaning set forth in Section 3.1(k)(v).
- 1.54 “Delivered Energy” means all Energy produced from the Project as measured in MWh at the CAISO revenue meter of the Project based on a power factor of precisely one (1) and net of all Electrical Losses.
- 1.55 “Delivery Point” means the point at which Buyer receives Seller’s Product, as identified in Section 3.1(d).
- 1.56 “Delivery Term” has the meaning set forth in Section 3.1(c).
- 1.57 “Delivery Term Security” means the Performance Assurance that Seller is required to maintain, as specified in Article Eight, to secure performance of its obligations during the Delivery Term.
- 1.58 “Disclosing Party” has the meaning set forth in Section 10.7.
- 1.59 “Disclosure Order” has the meaning set forth in Section 10.7.
- 1.60 “DUNS” means the Data Universal Numbering System, which is a unique nine character identification number provided by Dun and Bradstreet.
- 1.61 “Early Termination Date” has the meaning set forth in Section 5.2.
- 1.62 “Effective Date” means the date on which all of the Conditions Precedent set forth in Section 2.4(a) have been satisfied or waived in writing by both Parties.
- 1.63 “Electrical Losses” means all applicable losses, including, but not limited to, the following: (a) any transmission or transformation losses between the CAISO revenue meter and the Delivery Point; and (b) the Distribution Loss Factor, if applicable.
- 1.64 “Electrician” means any person responsible for placing, installing, erecting, or connecting any electrical wires, fixtures, appliances, apparatus, raceways, conduits, solar photovoltaic cells or any part thereof, which generate, transmit, transform or utilize energy in any form or for any purpose.

1.65 “Electric System Upgrades” means any Network Upgrades, Distribution Upgrades, or Interconnection Facilities that are determined to be necessary by the CAISO or Participating Transmission Owner, as applicable, to physically and electrically interconnect the Project to the Participating Transmission Owner’s electric system for receipt of Energy at the Point of Interconnection (as defined in the CAISO Tariff) if connecting to the CAISO Grid, or the Interconnection Point, if the Participating TO’s electric system is not part of the CAISO Grid.

1.66 “Eligible Intermittent Resource Program” or “EIRP” means the Eligible Intermittent Resource Protocol, as may be amended from time to time, as set forth in the CAISO Tariff.

1.67 “Eligible Renewable Energy Resource” or “ERR” has the meaning set forth in California Public Utilities Code Section 399.12 and California Public Resources Code Section 25741, as either code provision is amended or supplemented from time to time.

1.68 “Energy” means three-phase, 60-cycle alternating current electric energy measured in MWh and net of auxiliary loads and station electrical uses (unless otherwise specified). For purposes of Section 1.104, “Green Attributes,” the word “energy” shall have the meaning set forth in this definition.

1.69 “Energy Deviation(s)” means the absolute value of the difference, in MWh, in any Settlement Interval between (a) the final accepted Bid (as defined in the CAISO Tariff) submitted for the Project for the hour of the Settlement Interval divided by the number of Settlement Intervals in the hour; and (b) Delivered Energy for the Settlement Interval.

1.70 “Energy Investment Tax Credit” or “ITC” means the tax credit for “energy property” described in Section 48(a)(3)(A)(i) and 48(a)(5) of the Internal Revenue Code of 1986, as it may be amended or supplemented from time to time.

1.71 “Energy Supply Bid” has the meaning set forth in the CAISO Tariff.

1.72 "enXco QF Agreements" are set forth in Appendix XIX.

1.73 “EPC Contract” means the Seller’s engineering, procurement and construction contract with the EPC Contractor.

1.74 “EPC Contractor” means an engineering, procurement, and construction contractor, or if not utilizing an engineering, procurement and construction contractor, the entity having lead responsibility for the management of overall construction activities, selected by Seller, with substantial experience in the engineering, procurement, and construction of power plants of the same type of generating facility as the Seller’s; provided, however, that the Seller or the Seller’s affiliate(s) may serve as the EPC Contractor.

1.75 “Equitable Defenses” means any bankruptcy, insolvency, reorganization or other Laws affecting creditors’ rights generally and, with regard to equitable remedies, the discretion of the court before which proceedings may be pending to obtain same.

1.76 “Event of Default” has the meaning set forth in Section 5.1.

1.77 “Exclusivity Period” has the meaning set forth in Section 11.2(b)(i).

1.78 “Execution Date” means the latest signature date found on the signature page of this Agreement.

1.79 “Executive(s)” has the meaning set forth in Section 12.2(a).

1.80 “Exempt Wholesale Generator” has the meaning provided in 18 CFR Section 366.1

1.81 “FERC” means the Federal Energy Regulatory Commission or any successor government agency.

1.82 “Final Output Report” means the unabridged and unredacted final report provided to Buyer as set forth in Section 3.9(a)(vii) concerning the Energy producing potential of the Site, inclusive of anticipated Planned Outages and Forced Outages on an annual basis, prepared by a Licensed Professional Engineer who shall be retained by Seller. The Energy producing potential of the Site as reflected in the Final Output Report may be expressed on a calendar year by calendar year basis, if necessary to reflect adjustments in such potential over time due to any anticipated degradation of the photovoltaic panels.

1.83 “Final True-Up” means the final payment made pursuant to this Agreement settling all invoices by the Party with an outstanding net amount due to the other Party for the Products delivered prior to the end of the Delivery Term or other amounts due pursuant to this Agreement incurred prior to the end of the Delivery Term.

1.84 “First Offer” has the meaning set forth in Section 11.2(b)(i), as applicable.

1.85 “Force Majeure” means any event or circumstance which wholly or partly prevents or delays the performance of any material obligation arising under this Agreement, but only if and to the extent (i) such event is not within the reasonable control, directly or indirectly, of the Party seeking to have its performance obligation(s) excused thereby, (ii) the Party seeking to have its performance obligation(s) excused thereby has taken all reasonable precautions and measures in order to prevent or avoid such event or mitigate the effect of such event on such Party’s ability to perform its obligations under this Agreement and which by the exercise of due diligence such Party could not reasonably have been expected to avoid and which by the exercise of due diligence it has been unable to overcome, and (iii) such event is not the direct or indirect result of the negligence or the failure of, or caused by, the Party seeking to have its performance obligations excused thereby.

(a) Subject to the foregoing, events that could qualify as Force Majeure include, but are not limited to, the following:

(i) flooding, lightning, landslide, earthquake, fire, drought, explosion, epidemic, quarantine, storm, hurricane, tornado, volcanic eruption, other natural disaster or unusual or extreme adverse weather-related events;

(ii) war (declared or undeclared), riot or similar civil disturbance, acts of the public enemy (including acts of terrorism), sabotage, blockade, insurrection, revolution, expropriation or confiscation;

(iii) except as set forth in subsection (b)(vii) below, strikes, work stoppage or other labor disputes (in which case the affected Party shall have no obligation to settle the strike or labor dispute on terms it deems unreasonable); or

(iv) emergencies declared by the Transmission Provider or any other authorized successor or regional transmission organization or any state or federal regulator or legislature requiring a forced curtailment of the Project or making it impossible for the Transmission Provider to transmit Energy, including Energy to be delivered pursuant to this Agreement; provided that, if a curtailment of the Project pursuant to this subsection (a)(iv) would also meet the definition of a Curtailment Period, then it shall be treated as a Curtailment Period for purposes of Section 3.1(i).

(b) Force Majeure shall not be based on:

(i) Buyer's inability economically to use or resell the Product purchased hereunder;

(ii) Seller's ability to sell the Product at a price greater than the price set forth in this Agreement;

(iii) Seller's inability to obtain permits or approvals of any type for the construction, operation, or maintenance of the Project;

(iv) Seller's inability to obtain sufficient fuel, power or materials to operate the Project, except if Seller's inability to obtain sufficient fuel, power or materials is caused solely by an event of Force Majeure of the specific type described in any of subsections (a)(i) through (a)(iv) above;

(v) Seller's failure to obtain additional funds, including funds authorized by a state or the federal government or agencies thereof, to supplement the payments made by Buyer pursuant to this Agreement;

(vi) a Forced Outage except where such Forced Outage is caused by an event of Force Majeure of the specific type described in any of subsections (a)(i) through (a)(iv) above;

(vii) a strike, work stoppage or labor dispute limited only to any one or more of Seller, Seller's Affiliates, the EPC Contractor or subcontractors thereof or any other third party employed by Seller to work on the Project;

(viii) any equipment failure except if such equipment failure is caused solely by an event of Force Majeure of the specific type described in any of subsections (a)(i) through (a)(iv) above; or

(ix) a Party's inability to pay amounts due to the other Party under this Agreement, except if such inability is caused solely by a Force Majeure event that disables physical or electronic facilities necessary to transfer funds to the payee Party.

1.86 "Force Majeure Construction Extension" has the meaning set forth in Section 3.9(c)(iii)(A)(III).

1.87 “Force Majeure Failure” means either Force Majeure Project Failure or Force Majeure Development Failure, as applicable.

1.88 “Force Majeure Development Failure” has the meaning set forth in Section 11.2(a)(ii).

1.89 “Force Majeure Project Failure” has the meaning set forth in Section 11.2(a)(i).

1.90 “Forced Outage” means any unplanned reduction or suspension of the electrical output from the Project or unavailability of the Project in whole or in part from a Unit in response to a mechanical, electrical, or hydraulic control system trip or operator-initiated trip in response to an alarm or equipment malfunction and any other unavailability of a Unit for operation, in whole or in part, for maintenance or repair that is not a Planned Outage and not the result of Force Majeure.

1.91 “Forecasting Penalty” has the meaning set forth in Section 4.5(c)(iii), and “Forecasting Penalties” means more than one Forecasting Penalty.

1.92 “Full Capacity Deliverability Status” has the meaning set forth in the CAISO Tariff.

1.93 “Full Capacity Deliverability Status Finding” shall mean a finding by the CAISO that the Project meets the CAISO's requirements for deliverability at the Project's Full Capacity Deliverability Status, as such term is defined in the CAISO Tariff.

1.94 “Gains” means with respect to any Party, an amount equal to the present value of the economic benefit to it, if any (exclusive of Costs), resulting from the termination of the Transaction, determined in a commercially reasonable manner, subject to Section 5.3 hereof. Factors used in determining economic benefit may include, without limitation, reference to information either available to it internally or supplied by one or more third parties, including, without limitation, quotations (either firm or indicative) of relevant rates, prices, yields, yield curves, volatilities, spreads or other relevant market data in the relevant markets, market price referent, market prices for a comparable transaction, forward price curves based on economic analysis of the relevant markets, settlement prices for a comparable transaction at liquid trading platforms (e.g., NYMEX), all of which should be calculated for the remaining Delivery Term to determine the value of the Product.

1.95 “Generally Accepted Accounting Principles” means the standards for accounting and preparation of financial statements established by the Federal Accounting Standards Advisory Board (or its successor agency) or any successor standards adopted pursuant to relevant SEC rule.

1.96 “GEP Cure” has the meaning set forth in Section 3.1(e)(ii).

1.97 “GEP Damages” has the meaning set forth in Section 3.1(e)(ii).

1.98 “GEP Failure” means Seller's failure to produce Delivered Energy in an amount equal to or greater than the Guaranteed Energy Production amount for the applicable Performance Measurement Period.

1.99 “GEP Shortfall” means the amount in MWh by which Seller failed to achieve the Guaranteed Energy Production in the applicable Performance Measurement Period.

1.100 “Good Utility Practice” has the meaning provided in the CAISO Tariff.

1.101 “Governmental Approval” means all authorizations, consents, approvals, waivers, exceptions, variances, filings, permits, orders, licenses, exemptions and declarations of or with any governmental entity and shall include those siting and operating permits and licenses, and any of the foregoing under any applicable environmental Law, that are required for the construction, use and operation of the Project.

1.102 “Governmental Authority” means any federal, state, local or municipal government, governmental department, commission, board, bureau, agency, or instrumentality, or any judicial, regulatory or administrative body, having jurisdiction as to the matter in question.

1.103 “Governmental Charges” has the meaning set forth in Section 9.2.

1.104 “Green Attributes” means any and all credits, benefits, emissions reductions, offsets, and allowances, howsoever entitled, attributable to the generation from the Project, and its avoided emission of pollutants. Green Attributes include but are not limited to Renewable Energy Credits, as well as: (1) any avoided emission of pollutants to the air, soil or water such as sulfur oxides (SO_x), nitrogen oxides (NO_x), carbon monoxide (CO) and other pollutants; (2) any avoided emissions of carbon dioxide (CO₂), methane (CH₄), nitrous oxide, hydrofluorocarbons, perfluorocarbons, sulfur hexafluoride and other greenhouse gases (GHGs) that have been determined by the United Nations Intergovernmental Panel on Climate Change, or otherwise by law, to contribute to the actual or potential threat of altering the Earth’s climate by trapping heat in the atmosphere;¹ (3) the reporting rights to these avoided emissions, such as Green Tag Reporting Rights. Green Tag Reporting Rights are the right of a Green Tag Purchaser to report the ownership of accumulated Green Tags in compliance with federal or state law, if applicable, and to a federal or state agency or any other party at the Green Tag Purchaser’s discretion, and include without limitation those Green Tag Reporting Rights accruing under Section 1605(b) of The Energy Policy Act of 1992 and any present or future federal, state, or local law, regulation or bill, and international or foreign emissions trading program. Green Tags are accumulated on a MWh basis and one Green Tag represents the Green Attributes associated with one (1) MWh of Energy. Green Attributes do not include (i) any energy, capacity, reliability or other power attributes from the Project, (ii) production tax credits associated with the construction or operation of the Project and other financial incentives in the form of credits, reductions, or allowances associated with the project that are applicable to a state or federal income taxation obligation, (iii) fuel-related subsidies or “tipping fees” that may be paid to Seller to accept certain fuels, or local subsidies received by the generator for the destruction of particular preexisting pollutants or the promotion of local environmental benefits, or (iv) emission reduction credits encumbered or used by the Project for compliance with local, state, or federal operating and/or air quality permits. If the Project is a biomass or biogas facility and Seller receives any tradable Green Attributes based on the greenhouse gas reduction benefits or other emission offsets

¹ Avoided emissions may or may not have any value for GHG compliance purposes. Although avoided emissions are included in the list of Green Attributes, this inclusion does not create any right to use those avoided emissions to comply with any GHG regulatory program.

attributed to its fuel usage, it shall provide Buyer with sufficient Green Attributes to ensure that there are zero net emissions associated with the production of electricity from the Project.

1.105 “Guaranteed Commercial Operation Date” has the meaning set forth in Section 3.9(c)(iii)(C).

1.106 “Guaranteed Construction Start Date” has the meaning set forth in Section 3.9(c)(iii)(A).

1.107 “Guaranteed Energy Production” or “GEP” has the meaning set forth in Section 3.1(e)(ii).

1.108 “Guaranteed Project Milestones” are the Guaranteed Construction Start Date and the Guaranteed Commercial Operation Date set forth in 3.9(c)(iii).

1.109 “Guaranty” means a guaranty issued by an entity acceptable to Buyer and in a form acceptable to Buyer.

1.110 “Hour-Ahead Scheduling Process” has the meaning set forth in the CAISO Tariff.

1.111 “Initial Energy Delivery Date” has the meaning set forth in Section 3.1(c).

1.112 “Initial Negotiation End Date” has the meaning set forth in Section 12.2(a).

1.113 “Interconnection Customer’s Interconnection Facilities” has the meaning set forth in the CAISO Tariff.

1.114 “Interconnection Facilities” has the meaning set forth in the CAISO Tariff.

1.115 “Interconnection Point” means the Project’s first point of interconnection to the CAISO Grid at the Birds Landing Switching Station, as specified in Seller’s interconnection agreement.

1.116 “Interest Amount” means, with respect to an Interest Period, the amount of interest calculated as follows: (a) the sum of (i) the principal amount of Performance Assurance in the form of cash held by Buyer during that Interest Period, and (ii) the sum of all accrued and unpaid Interest Amounts accumulated prior to such Interest Period; (b) multiplied by the Interest Rate in effect for that Interest Period; (c) multiplied by the number of days in that Interest Period; (d) divided by 360.

1.117 “Interest Payment Date” means the date of returning unused Performance Assurance held in the form of cash.

1.118 “Interest Period” means the monthly period beginning on the first day of each month and ending on the last day of each month.

1.119 “Interest Rate” means the rate per annum equal to the “Monthly” Federal Funds Rate (as reset on a monthly basis based on the latest month for which such rate is available) as reported in Federal Reserve Bank Publication H.15-519, or its successor publication.

1.120 “JAMS” means JAMS, Inc. or its successor entity, a judicial arbitration and mediation service.

1.121 “Law” means any statute, law, treaty, rule, regulation, CEC guidance document, ordinance, code, permit, enactment, injunction, order, writ, decision, authorization, judgment, decree or other legal or regulatory determination or restriction by a court or Governmental Authority of competent jurisdiction, including any of the foregoing that are enacted, amended, or issued after the Execution Date, and which becomes effective after the Execution Date; or any binding interpretation of the foregoing. For purposes of Sections 1.41 “CPUC Approval,” 1.104 “Green Attributes,” 10.2(b), “Seller Representations and Warranties” and 10.12 “Governing Law”, the term “law” shall have the meaning set forth in this definition.

1.122 “Letter(s) of Credit” means an irrevocable, non-transferable standby letter of credit (a) issued either by (i) a U.S. commercial bank, or (ii) a U.S. branch or subsidiary of a foreign commercial bank that meets the following conditions: (A) it has sufficient assets in the U.S. as determined by Buyer, and (B) it is acceptable to Buyer in its sole discretion; (b) for which the issuing U.S. bank, or foreign bank or subsidiary thereof, must have a Credit Rating of at least A from S&P or A2 from Moody’s; and (c) the form of which must be substantially in the form as contained in Appendix I to this Agreement; provided, that, if the Letter of Credit is issued by a branch of a foreign bank, Buyer may require changes to such form.

1.123 “LGIA” means the agreement and associated documents (or any successor agreement and associated documentation approved by FERC) by and among Seller, the Participating Transmission Owner, and the CAISO governing the terms and conditions of Seller’s interconnection with the Participating TO’s Transmission System, including any description of the plan for interconnecting to Participating TO’s Transmission System.

1.124 “LGIP” means the Large Generator Interconnection Procedures set forth in the CAISO Tariff and associated documents; provided that if the LGIP is replaced by such other successor procedures approved by FERC governing interconnection (a) to the Participating TO’s Transmission System or (b) of generating facilities with an expected net capacity equal to or greater than the Project’s Contract Capacity, the term “LGIP” shall then apply to such successor procedure.

1.125 “Licensed Professional Engineer” means a person acceptable to Buyer in its reasonable judgment who (a) is licensed to practice engineering in California, (b) has training and experience in the power industry specific to the technology of the Project, (c) has no economic relationship, association, or nexus with Seller or Buyer, other than to meet the obligations of Seller pursuant to this Agreement, (d) is not a representative of a consultant, engineer, contractor, designer or other individual involved in the development of the Project or of a manufacturer or supplier of any equipment installed at the Project, and (e) is licensed in an appropriate engineering discipline for the required certification being made.

1.126 “Losses” means, with respect to any Party, an amount equal to the present value of the economic loss to it, if any (exclusive of Costs), resulting from the termination of the Transaction, determined in a commercially reasonable manner, subject to Section 5.3 hereof. Factors used in determining the loss of economic benefit may include, without limitation, reference to information either available to it internally or supplied by one or more third parties including, without limitation, quotations (either firm or indicative) of relevant rates, prices, yields, yield curves, volatilities, spreads or other relevant market data in the relevant markets, market price referent, market prices for a comparable transaction, forward price curves based on

economic analysis of the relevant markets, settlement prices for a comparable transaction at liquid trading platforms (e.g. NYMEX), all of which should be calculated for the remaining term of the Transaction to determine the value of the Product. If the Non-Defaulting Party is the Seller, then “Losses” shall exclude any loss of Production Tax Credits, Energy Investment Tax Credits, or other federal or state tax credits, grants, or benefits related to the Project or generation therefrom.

1.127 “Manager” has the meaning set forth in Section 12.2(a).

1.128 “Milestones” means the key development activities required for the construction and operation of the Project, as set forth in Appendix III.

1.129 “Monthly Progress Report” means the report similar in form and content attached hereto as Attachment A to Appendix III.

1.130 “Moody’s” means Moody’s Investors Service, Inc., or its successor.

1.131 “MW” means megawatt (AC).

1.132 “MWh” means megawatt-hour.

1.133 “NERC” means the North American Electric Reliability Council or a successor organization that is responsible for establishing reliability criteria and protocols.

1.134 “Network Upgrades” has the meaning set forth in the CAISO Tariff.

1.135 “New Generation Facility” means a project that (a) has not previously been operational and able to produce and deliver Energy to another entity or (b) must be re-powered or expanded in order to deliver the Product pursuant to the terms set forth in this Agreement.

1.136 “NOAA” means National Oceanic and Atmospheric Administration or successor thereto.

1.137 “Non-Defaulting Party” has the meaning set forth in Section 5.2.

1.138 “Notice,” unless otherwise specified in the Agreement, means written communications by a Party to be delivered by hand delivery, United States mail, overnight courier service, facsimile or electronic messaging (e-mail). Appendix XI contains the names and addresses to be used for Notices.

1.139 “Notice to Proceed” means the notice provided by Seller to the EPC Contractor following execution of the EPC Contract between Seller and such EPC Contractor and satisfaction of all conditions to performance of such contract, by which Seller authorizes such EPC Contractor to begin construction of the Project without any delay or waiting periods.

1.140 “Obligor” means the Party breaching the terms of this Agreement.

1.141 “Outage Notification Procedures” means the procedures specified in Appendix VIII, attached hereto. PG&E reserves the right to revise or change the procedures upon written Notice to Seller.

1.142 “Participating Intermittent Resource” or “PIRP” has the meaning set forth in the CAISO Tariff.

1.143 “Participating Transmission Owner” or “Participating TO” means an entity that (a) owns, operates and maintains transmission lines and associated facilities and/or has entitlements to use certain transmission lines and associated facilities and (b) has transferred to the CAISO operational control of such facilities and/or entitlements to be made part of the CAISO Grid. For purposes of this Agreement, the Participating Transmission Owner is Pacific Gas and Electric Company.

1.144 “Party” means the Buyer or Seller individually, and “Parties” means both collectively. For purposes of Section 10.12, Governing Law, the word “party” or “parties” shall have the meaning set forth in this definition.

1.145 “Performance Assurance” means collateral provided by Seller to Buyer to secure Seller’s obligations hereunder and includes Project Development Security and Delivery Term Security.

1.146 “Performance Measurement Period” has the meaning set forth in Section 3.1(e).

1.147 “Performance Tolerance Band” shall be calculated as set forth in Section 4.5(c)(ii).

1.148 “Permitted Extensions” means extensions to either of the Guaranteed Project Milestones due to Force Majeure Construction Extension as applicable to each Guaranteed Project Milestone pursuant to Section 3.9(c)(iii)(A) or (B), as applicable.

1.149 “Planned Outage” means the removal of equipment from service availability for inspection and/or general overhaul of one or more major equipment groups. To qualify as a Planned Outage, the maintenance (a) must actually be conducted during the Planned Outage, and in Seller’s sole discretion must be of the type that is necessary to reliably maintain the Project, (b) cannot be reasonably conducted during Project operations, and (c) causes the generation level of the Project to be reduced by at least ten percent (10%) of the Contract Capacity.

1.150 “PNode” has the meaning set forth in the CAISO Tariff.

1.151 “Preamble” means the paragraph that precedes Article One: General Definitions to this Agreement.

1.152 “Preschedule Day” has the meaning set forth in Section 3.4(c)(iii).

1.153 “Product” means the Energy, capacity and all ancillary products, services or attributes similar to the foregoing which are or can be produced by or associated with the Project, including, without limitation, renewable attributes, Renewable Energy Credits, Capacity Attributes and Green Attributes.

1.154 “Production Tax Credit” or “PTC” means the tax credit for electricity produced from certain renewable generation resources described in Section 45 of the Internal Revenue Code of 1986, as it may be amended or supplemented from time to time.

1.155 “Project” means all of the Unit(s), the Site at which the generating facility is located and the other assets, tangible and intangible, that compose the generation facility, including but not limited to the assets used to connect the Unit(s) to the Interconnection Point, as

more particularly described on Appendix IV. For purposes of Section 1.104, “Green Attributes,” the word “project” shall have the meaning set forth in this definition.

1.156 “Project Cure Period” has the meaning set forth in Section 3.9(c)(iv).

1.157 “Project Development Security” is the collateral required of Seller, as specified and referred to in Section 8.4(a).

1.158 “Prolonged Outage” is any period of more than thirty (30) consecutive days during which the Project is or will be unable, for whatever reason, to provide at least sixty percent (60%) of the Contract Capacity.

1.159 “QF Amendments” means the amendments to the enXco QF Agreements to be executed concurrently with this Agreement.

1.160 “RA Capacity” means the maximum megawatt amount that the CAISO recognizes from a Project that qualifies for Buyer’s Resource Adequacy Requirements and is associated with the Project’s Capacity Attributes.

1.161 “Real-Time Price” means the Resource-Specific Settlement Interval LMP as defined in the CAISO Tariff.

1.162 “Reductions” has the meaning set forth in Section 4.7(b).

1.163 “Referral Date” has the meaning set forth in Section 12.2(a).

1.164 “Reliability Coordinator” has the meaning set forth in the CAISO Tariff.

1.165 “Remedial Action Plan” has the meaning provided in Section 3.9(c)(ii).

1.166 “Renewable Energy Credit” has the meaning set forth in California Public Utilities Code Section 399.12(f) and CPUC Decision 08-08-028, as may be amended from time to time or as further defined or supplemented by Law.

1.167 “Replacement Capacity Rules” means the program set forth in the CAISO Tariff, as it may be amended, supplemented or replaced (in whole or in part) from time to time, setting forth certain requirements to replace Resource Adequacy Capacity on planned outages.

1.168 “Resource Adequacy” means the procurement obligation of load serving entities, including Buyer, as such obligations are described in CPUC Decisions D.04-10-035 and D.05-10-042 and subsequent CPUC decisions addressing Resource Adequacy issues, as those obligations may be altered from time to time in the CPUC Resource Adequacy Rulemakings (R.) 04-04-003 and (R.) 05-12-013 or by any successor proceeding, and all other Resource Adequacy obligations established by any other entity, including the CAISO.

1.169 “Resource Adequacy Requirements” has the meaning set forth in Section 3.3.

1.170 “Revised Offer” has the meaning set forth in Section 11.2(b)(iii).

1.171 “S&P” means the Standard & Poor’s Financial Services, LLC (a subsidiary of The McGraw-Hill Companies, Inc.) or its successor.

- 1.172 “Satisfaction Date” has the meaning set forth in Section 2.6.
- 1.173 “Schedule” has the meaning set forth in the CAISO Tariff.
- 1.174 “Scheduling Coordinator” or “SC” means an entity certified by the CAISO as qualifying as a Scheduling Coordinator pursuant to the CAISO Tariff, for the purposes of undertaking the functions specified in “Responsibilities of a Scheduling Coordinator”, of the CAISO Tariff, as amended from time to time.
- 1.175 “SEC” means the U.S. Securities and Exchange Commission.
- 1.176 “Self-Schedule” has the meaning set forth in the CAISO Tariff.
- 1.177 “Seller” has the meaning set forth in the Preamble.
- 1.178 “Seller Excuse Hours” means those hours during which Seller is unable to schedule or deliver Delivered Energy to Buyer as a result of (a) a Force Majeure event, (b) Buyer’s failure to perform, (c) Curtailment Period or (d) Buyer Curtailment Period; provided that, in the case of a Buyer Curtailment Period, for each hour in which less than 100% of the Project output is curtailed, the Seller Excuse Hours will increase by the product of (a) one hour multiplied by (b) the ratio of (i) Deemed Delivered Energy associated with that hour to (ii) the sum of Deemed Delivered Energy associated with that hour plus Delivered Energy associated with that hour.
- 1.179 “Seller’s WREGIS Account” has the meaning set forth in Section 3.1(k)(i).
- 1.180 “Settlement Amount” means the amount in US\$ equal to the sum of Losses, Gains, and Costs, which the Non-Defaulting Party incurs as a result of the termination of this Agreement.
- 1.181 “Settlement Interval” means any one of the six ten (10) minute time intervals beginning on any hour and ending on the next hour (e.g. 12:00 to 12:10, 12:10 to 12:20, etc.).
- 1.182 “Settlement Interval Actual Available Capacity” means the sum of the capacity, in MWs, of all Units that were available as of the end of such Settlement Interval, as indicated by the Actual Availability Report.
- 1.183 “Site” means the location of the Project as described in Appendix IV.
- 1.184 “System Emergency” has the meaning provided in Section 1.44 (“Curtailed Order”).
- 1.185 “Term” has the meaning provided in Section 2.6.
- 1.186 “Terminated Transaction” means the Transaction terminated in accordance with Section 5.2 of this Agreement.
- 1.187 “Termination Payment” means the payment amount equal to the sum of (a) and (b), where (a) is the Settlement Amount and (b) is the sum of all amounts owed by the Defaulting Party to the Non-Defaulting Party under this Agreement, less any amounts owed by the Non-Defaulting Party to the Defaulting Party determined as of the Early Termination Date.

1.188 “Test Period” means the period of not more than ninety (90) consecutive days commencing on the first date that the CAISO informs Seller in writing that Seller may deliver Energy from the Project to the CAISO Grid and ending when Seller advises Buyer of the occurrence of the Initial Energy Delivery Date.

1.189 “Third-Party SC” means a qualified third party designated by Buyer to provide the Scheduling Coordinator functions for the Project pursuant to this Agreement.

1.190 “Transaction” means the particular transaction described in its entirety in Section 3.1(b) of this Agreement.

1.191 “Transmission Provider” means any entity or entities transmitting or transporting the Product on behalf of Seller or Buyer to or from the Delivery Point. For purposes of this Agreement the Transmission Provider is CAISO.

1.192 “Unit” means the RE Power 2.0 MW wind turbine generators, the Vestas 2.0 MW wind turbine generators and/or the General Electric 1.5 MW wind turbine generators used to produce the Products, which are identified in Appendix IV for the Transaction entered into under this Agreement.

1.193 “WECC” means the Western Electricity Coordinating Council or successor agency.

1.194 “WREGIS” means the Western Renewable Energy Generation Information System or any successor renewable energy tracking program.

1.195 “WREGIS Certificate Deficit” has the meaning set forth in Section 3.1(k)(v).

1.196 “WREGIS Certificates” has the same meaning as “Certificate” as defined by WREGIS in the WREGIS Operating Rules and are designated as eligible for complying with the California Renewables Portfolio Standard.

1.197 “WREGIS Operating Rules” means those operating rules and requirements adopted by WREGIS as of June 4, 2007, as subsequently amended, supplemented or replaced (in whole or in part) from time to time.

1.198 “Work” means (a) work or operations performed by a Party or on a Party’s behalf, and (b) materials, parts or equipment furnished in connection with such work or operations, including (i) warranties or representations made at any time with respect to the fitness, quality, durability, performance or use of “a Party’s work”, and (ii) the providing of or failure to provide warnings or instructions.

ARTICLE TWO: GOVERNING TERMS AND TERM

2.1 Entire Agreement. This Agreement, together with the Preamble and each and every appendix, attachment, amendment, schedule and any written supplements hereto, if any, between the Parties constitutes the entire, integrated agreement between the Parties.

2.2 Interpretation. The following rules of interpretation shall apply in addition to those set forth in Section 10.13:

(a) The term “month” shall mean a calendar month unless otherwise indicated, and a “day” shall be a 24-hour period beginning at 12:00:01 a.m. Pacific Prevailing Time and ending at 12:00:00 midnight Pacific Prevailing Time; provided that a “day” may be 23 or 25 hours on those days on which daylight savings time begins and ends.

(b) Unless otherwise specified herein, all references herein to any agreement or other document of any description shall be construed to give effect to amendments, supplements, modifications or any superseding agreement or document as then existing at the applicable time to which such construction applies.

(c) Capitalized terms used in this Agreement, including the appendices hereto, shall have the meaning set forth in Article One, unless otherwise specified.

(d) Unless otherwise specified herein, references in the singular shall include references in the plural and vice versa, pronouns having masculine or feminine gender will be deemed to include the other, and words denoting natural persons shall include partnerships, firms, companies, corporations, joint ventures, trusts, associations, organizations or other entities (whether or not having a separate legal personality). Other grammatical forms of defined words or phrases have corresponding meanings.

(e) References to a particular article, section, subsection, paragraph, subparagraph, appendix or attachment shall, unless specified otherwise, be a reference to that article, section, subsection, paragraph, subparagraph, appendix or attachment in or to this Agreement.

(f) Any reference in this Agreement to any natural person, Governmental Authority, corporation, partnership or other legal entity includes its permitted successors and assigns or to any natural person, Governmental Authority, corporation, partnership or other legal entity succeeding to its functions.

(g) All references to dollars are to U.S. dollars.

(h) The term “including” when used in this Agreement shall be by way of example only and shall not be considered in any way to be in limitation.

2.3 Authorized Representatives. Each Party shall provide Notice to the other Party of the persons authorized to nominate and/or agree to a schedule or dispatch order for the delivery or acceptance of the Product or make other Notices on behalf of such Party and specify the scope of their individual authority and responsibilities, and may change its designation of such persons from time to time in its sole discretion by providing Notice.

2.4 Separation of Functions. The Parties acknowledge that this Agreement is between (a) Seller and (b) Buyer acting solely in its merchant function. The Parties further acknowledge that they have no rights against each other or obligations to each other under this Agreement with respect to any relationship between the Parties in which PG&E is acting in its capacity as Participating Transmission Owner, including, but not limited to, orders or instructions relating to Electric System Upgrades and/or Curtailment Periods.

2.5 Conditions Precedent.

(a) Conditions Precedent. Subject to Section 2.7 hereof, the Term shall not commence until the occurrence of all of the following:

(i) This Agreement has been duly executed by the authorized representatives of each of Buyer and Seller;

(ii) CPUC Approval has been obtained;

(iii) Buyer receives a final and non-appealable order of the CPUC that finds that Buyer's entry into this Agreement is reasonable and that payments to be made by Buyer hereunder are recoverable in rates;

(iv) Each of the QF Amendments shall have been duly executed by authorized representatives of Buyer and the appropriate affiliates of Seller and the CPUC shall have issued an approval related to the QF Amendments in a form acceptable to the Parties; and

(v) Seller provides all of the documentation listed in Appendix XIII, (Seller Documentation Condition Precedent) by the date requested therein.

(b) Failure to Meet All Conditions Precedent. If the Conditions Precedent set forth in Sections 2.5(a)(ii), (iii) and (iv) are not satisfied or waived in writing by both Parties on or before two hundred forty (240) days from the date on which Buyer files this Agreement for CPUC Approval, then either Party may terminate this Agreement effective upon receipt of Notice by the other Party. Neither Party shall have any obligation or liability to the other, including for a Termination Payment or otherwise, by reason of such termination.

2.6 Term. (a) The term shall commence upon the satisfaction of the Conditions Precedent set forth in Section 2.5(a) of this Agreement and shall remain in effect until the conclusion of the Delivery Term unless terminated sooner pursuant to Sections 2.5(b), 5.2, or Section 11.2 of this Agreement (the "Term"); provided that this Agreement shall thereafter remain in effect (i) until the Parties have fulfilled all obligations with respect to the Transaction, including payment in full of amounts due pursuant to the Final True-Up, the Settlement Amount, or other damages (whether directly or indirectly such as through set-off or netting) and the undrawn portion of the Project Development Security or Delivery Term Security, as applicable, is released and/or returned as applicable (the "Satisfaction Date") or (ii) in accordance with the survival provisions set forth in subpart (b) below.

(b) Notwithstanding anything to the contrary in this Agreement, (i) all rights under Section 10.5 (Indemnities) and any other indemnity rights shall survive the Satisfaction Date or the end of the Term (whichever is later) for an additional twelve (12) months; (ii) all rights and obligations under Section 10.7 (Confidentiality) shall survive the Satisfaction Date or the end of the Term (whichever is later) for an additional two (2) years; and (iii) the right of first offer in Section 11.2(b) shall survive the Satisfaction Date for three (3) years.

2.7 Binding Nature.

(a) Upon Execution Date. This Agreement shall be effective and binding as of the Execution Date only to the extent required to give full effect to, and enforce, the rights and obligations of the Parties under:

(i) Sections 3.9(a)(vi), 5.1(a)(iv)-(v), and 5.1(b)(v);

(ii) Section 5.1(a)(ii) only with respect to Section 10.2, and Section 5.1(a)(iii) only with respect to the Sections identified in this Section 2.7;

(iii) Sections 5.2 through 5.7;

(iv) Sections 8.3, 8.4(a)(i), 8.4(b), and 8.5;

(v) Sections 10.2, 10.6 through 10.8, and Sections 10.12 through 10.15; and

(vi) Articles One, Two, Seven, Twelve and Thirteen.

(b) Upon Effective Date. This Agreement shall be in full force and effect, enforceable and binding in all respects, upon occurrence of the Effective Date.

ARTICLE THREE: OBLIGATIONS AND DELIVERIES

3.1 Seller's and Buyer's Obligations.

(a) Product. The Product to be delivered and sold by Seller and received and purchased by Buyer under this Agreement is an As-Available Product.

(b) Transaction. Unless specifically excused by the terms of this Agreement during the Delivery Term, Seller shall sell and deliver, or cause to be delivered, and Buyer shall purchase and receive, or cause to be received, the Product at the Delivery Point, and Buyer shall pay Seller the Contract Price in accordance with the terms of this Agreement. In no event shall Seller have the right (i) to procure any element of the Product from sources other than the Project for sale or delivery to Buyer under this Agreement except with respect to Energy delivered to Buyer in connection with Energy Deviations, as applicable, or (ii) sell Product from the Project to a third party other than in connection with Energy Deviations, as applicable. Buyer shall have no obligation to receive or purchase Product from Seller prior to or after the Delivery Term, except during the Test Period. Seller shall be responsible for any costs or charges imposed on or associated with the Product or its delivery of the Product up to the Delivery Point. Buyer shall be responsible for any costs or charges imposed on or associated with the Product after its receipt at and from the Delivery Point. Seller shall comply with Buyer's Supplier Diversity Program in accordance with Appendix XVIII. Each Party agrees to act in good faith in the performance of its obligations under this Agreement.

(c) Delivery Term. The Parties shall specify and agree to the period of Product delivery for the "Delivery Term," as defined herein, by checking one of the following boxes:

- Delivery shall be for a period of ten (10) Contract Years.
- Delivery shall be for a period of fifteen (15) Contract Years.
- Delivery shall be for a period of twenty (20) Contract Years.
- Non-standard Delivery shall be for a period of twenty-five (25) Contract Years.

As used herein, “Delivery Term” shall mean the period of Contract Years specified above beginning on the first date that Seller delivers Product to Buyer from the Project (“Initial Energy Delivery Date”) in connection with this Agreement and continuing until the end of the twenty-fifth(25th) Contract Year unless terminated as provided by the terms of this Agreement. The Initial Energy Delivery Date shall occur as soon as practicable once all of the following have been satisfied: (A) the Commercial Operation Date has occurred; (B) Buyer shall have received and accepted the Delivery Term Security in accordance with the relevant provisions of Article Eight of the Agreement, as applicable; (C) Seller shall have obtained the requisite CEC Certification and Verification for the Project; (D) subject to Section 3.9(c)(iv)(C), if the Contract Capacity is less than 100 MW, then Seller shall have paid all of the liquidated damages required pursuant to that section; (E) all of the applicable Conditions Precedent in Section 2.5(a) of the Agreement have been satisfied or waived in writing, and (F) Buyer shall have received written notice from the CAISO that the Project is certified as a Participating Intermittent Resource to the extent such status is available at such time as the conditions in subsections (A) through (E) of this Section 3.1(c) are satisfied, unless directed by Buyer, in its sole discretion, to not participate in such program. If subsection (F) is applicable, Seller shall obtain such certification no later than one hundred twenty (120) days following the Commercial Operation Date. As evidence of the Initial Energy Delivery Date, the Parties shall execute and exchange the “Initial Energy Delivery Date Confirmation Letter” attached hereto as Appendix II on the Initial Energy Delivery Date.

(d) Delivery Point. The Delivery Point shall be the PNode designated by the CAISO for the Project.

(e) Contract Quantity and Guaranteed Energy Production.

(i) Contract Quantity. The Contract Quantity during each Contract Year is the amount set forth in the applicable Contract Year in the “Delivery Term Contract Quantity Schedule,” attached hereto as Appendix V, which amount is inclusive of outages; provided that if Buyer has received a Capacity Reduction Notice in accordance with Section 3.9(c)(iv)(C) and Seller has paid the liquidated damages required pursuant to that section, then this Agreement, including Appendix V, shall be automatically amended to reflect the reduced Contract Quantity amount set forth in such notice.

(ii) Guaranteed Energy Production.

(A) Throughout the Delivery Term, Seller shall be required to deliver to Buyer no less than the Guaranteed Energy Production over two (2) consecutive Contract Years during the Delivery Term (“Performance Measurement Period”). “Guaranteed Energy Production” means an amount of Delivered Energy, as measured in MWh, equal to the product of (x) and (y), where (x) is one hundred sixty percent (160%) of the Contract Quantity, and (y) is the difference between (I) and (II), with the resulting difference divided by (I), where (I) is the number of hours in the applicable Performance Measurement Period and (II) is the aggregate number of Seller Excuse Hours in the applicable Performance Measurement Period. Guaranteed Energy Production is described by the following formula:

Guaranteed Energy Production = (160% * Contract Quantity in MWh) * [(Hrs in Performance Measurement Period – Seller Excuse Hrs) / Hrs in Performance Measurement Period]

(B) (I) If Seller has a GEP Failure, then within forty-five (45) days after the last day of the last month of such Performance Measurement Period, Buyer shall promptly notify Seller of such failure. Seller may cure the GEP Failure by delivering to Buyer no less than ninety percent (90%) of the Contract Quantity over the next following

Contract Year (“GEP Cure”). If Seller fails to generate sufficient Delivered Energy to make the GEP Cure for a given Performance Measurement Period, Seller shall pay GEP Damages, calculated pursuant to Appendix VII (GEP Damages Calculation).

(II) The Parties agree that the damages sustained by Buyer associated with Seller’s failure to achieve the Guaranteed Energy Production requirement would be difficult or impossible to determine, or that obtaining an adequate remedy would be unreasonably time consuming or expensive and therefore agree that Seller shall pay the GEP Damages to Buyer as liquidated damages. In no event shall Buyer be obligated to pay GEP Damages.

(III) After the GEP Cure period has run, if Seller has not achieved the GEP Cure, Buyer shall have forty-five (45) days to notify Seller of such failure. Within forty-five (45) days of the end of the GEP Cure period, Buyer shall provide Notice to Seller in writing of the amount of the GEP Damages, if any, which Seller shall pay within sixty (60) days of receipt of the Notice. If Seller does not pay the GEP Damages within the sixty (60) day time period, Buyer may, at its option, declare an Event of Default pursuant to Section 5.1(b)(vi)(A) within ninety (90) days after the expiration of Seller’s sixty (60) day GEP Cure period. If Buyer does not (1) notify Seller of the GEP Failure or (2) declare an Event of Default pursuant to Section 5.1(b)(vi) within the ninety (90) day period, if Seller has failed to pay the GEP Damages, then Buyer shall be deemed to have waived its right to declare an Event of Default based on Seller’s failure with respect to the Performance Measurement Period which served as the basis for the notice of GEP Failure, GEP Damages, or default, subject to the limitations set forth in Section 5.1(b)(vi)(B).

(f) Contract Capacity. The generation capability designated for the Project shall be 100 MW net of all auxiliary loads, station electrical uses, and Electrical Losses (the “Contract Capacity”); provided that if Buyer has received a Capacity Reduction Notice in accordance with Section 3.9(c)(iv)(C) and Seller has paid the liquidated damages required pursuant to that section, then this Agreement, including this Section 3.1(f) shall be automatically amended to reflect the reduced Contract Capacity set forth in such notice. Throughout the Delivery Term, Seller shall sell and Schedule all Product produced by the Project solely to Buyer and in no event shall Buyer be obligated to receive or pay for, in any hour, any Delivered Energy that exceeds the Contract Capacity.

(g) Project.

(i) All Product provided by Seller pursuant to this Agreement shall be supplied from the Project only. Seller shall not make any alteration or modification to the Project which results in a change to the Contract Capacity or the anticipated output of the Project without Buyer’s prior written consent; provided that nothing in this Section 3.1(g) shall limit Seller’s right to adjust the Contract Capacity pursuant to Section 3.9(c)(iv)(C). The Project is further described in Appendix IV.

(ii) Seller shall not relinquish its possession or demonstrable exclusive right to control the Project without the prior written consent of Buyer, except under circumstances provided in Section 10.6. Seller shall be deemed to have relinquished possession of the Project if after the Commercial Operation Date Seller has ceased work on the Project or ceased production and delivery of Product for a consecutive thirty (30) day period and such cessation is not a result of a Force Majeure event or direct action of Buyer.

(h) Interconnection Facilities.

(i) Seller Obligations. Seller shall (A) arrange and pay independently for any and all necessary costs under any interconnection agreement with the Participating Transmission Owner; (B) cause the Interconnection Customer's Interconnection Facilities, including metering facilities to be maintained; (C) comply with the procedures set forth in the LGIP and applicable agreements or procedures provided under the LGIP in order to obtain the applicable Electric System Upgrades and (D) obtain Electric System Upgrades, as needed, in order to ensure the safe and reliable delivery of Energy from the Project up to and including quantities that can be produced utilizing all of the Contract Capacity of the Project during the times at which such delivery is anticipated under this Agreement.

(ii) Coordination with Buyer. Seller shall (A) provide to Buyer copies of all material correspondence related thereto; and (B) provide Buyer with written reports of the status of the LGIA and Electric System Upgrades, if applicable, on a monthly basis. The foregoing shall not preclude Seller from executing an LGIA that it reasonably determines allows it to comply with its obligations under this Agreement and applicable Law.

(i) Performance Excuses.

(i) Seller Excuses. Seller shall be excused from achieving the Guaranteed Energy Production for the applicable time period during Seller Excuse Hours.

(ii) Buyer Excuses. The performance of Buyer to receive and/or pay for the Product shall be excused only (A) during periods of Force Majeure, (B) by Seller's failure to perform, (C) during Curtailment Periods or (D) during Buyer Curtailment Periods.

(iii) Curtailment. Notwithstanding Section 3.1(b) and this Section 3.1(i), Seller shall reduce output from the Project during any Curtailment Period or Buyer Curtailment Periods.

(iv) No Excuse. Except for a failure or curtailment resulting from a Force Majeure or during a Curtailment Period, the failure of electric transmission or distribution service shall not excuse performance with respect to either Party for the delivery or receipt of Energy to be provided under this Agreement.

(j) Greenhouse Gas Emissions Reporting. During the Term, Seller acknowledges that a Governmental Authority may require Buyer to take certain actions with respect to greenhouse gas emissions attributable to the generation of Energy, including, but not limited to, reporting, registering, tracking, allocating for or accounting for such emissions. Promptly following Buyer's written request, Seller agrees to take all commercially reasonable actions and execute or provide any and all documents, information or instruments with respect to generation by the Project reasonably necessary to permit Buyer to comply with such requirements, if any.

(k) WREGIS. Seller shall, at its sole expense, take all actions and execute all documents or instruments necessary to ensure that all WREGIS Certificates associated with all Renewable Energy Credits corresponding to all Delivered Energy are issued and tracked for purposes of satisfying the requirements of the California Renewables Portfolio Standard and transferred in a timely manner to Buyer for Buyer's sole benefit. Seller shall transfer the Renewable Energy Credits to Buyer even if Buyer does not accept and/or pay for the underlying

energy per Section 3.1(f). Seller shall comply with all Laws, including, without limitation, the WREGIS Operating Rules, regarding the certification and transfer of such WREGIS Certificates to Buyer and Buyer shall be given sole title to all such WREGIS Certificates. Seller shall be deemed to have satisfied the warranty in Section 3.1(k)(viii), provided that Seller fulfills its obligations under Sections 3.1(k)(i) through (vii) below. In addition:

(i) Prior to the Initial Energy Delivery Date, Seller shall register the Project with WREGIS and establish an account with WREGIS (“Seller’s WREGIS Account”), which Seller shall maintain until the end of the Delivery Term. Seller shall transfer the WREGIS Certificates using “Forward Certificate Transfers” (as described in the WREGIS Operating Rules) from Seller’s WREGIS Account to the WREGIS account(s) of Buyer or the account(s) of a designee that Buyer identifies by Notice to Seller (“Buyer’s WREGIS Account”). Seller shall be responsible for all expenses associated with registering the Project with WREGIS, establishing and maintaining Seller’s WREGIS Account, paying WREGIS Certificate issuance and transfer fees, and transferring WREGIS Certificates from Seller’s WREGIS Account to Buyer’s WREGIS Account.

(ii) Seller shall cause Forward Certificate Transfers to occur on a monthly basis in accordance with the certification procedure established by the WREGIS Operating Rules. Since WREGIS Certificates will only be created for whole MWh amounts of Energy generated, any fractional MWh amounts (i.e., kWh) will be carried forward until sufficient generation is accumulated for the creation of a WREGIS Certificate.

(iii) Seller shall, at its sole expense, ensure that the WREGIS Certificates for a given calendar month correspond with the Delivered Energy for such calendar month as evidenced by the Project’s metered data.

(iv) Due to the ninety (90) day delay in the creation of WREGIS Certificates relative to the timing of invoice payment under Article 6, Buyer shall make an invoice payment for a given month in accordance Article 6 before the WREGIS Certificates for such month are formally transferred to Buyer in accordance with the WREGIS Operating Rules and this Section 3.1(k). Notwithstanding this delay, Buyer shall have all right and title to all such WREGIS Certificates upon payment to Seller in accordance with Article 6.

(v) A “WREGIS Certificate Deficit” means any deficit or shortfall in WREGIS Certificates delivered to Buyer for a calendar month as compared to the Delivered Energy for the same calendar month (“Deficient Month”). If any WREGIS Certificate Deficit is caused, or the result of any action or inaction, by Seller, then the amount of Delivered Energy in the Deficient Month shall be reduced by the amount of the WREGIS Certificate Deficit for the purposes of calculating Buyer’s payment(s) to Seller under Article 6 and the Guaranteed Energy Production for the applicable Performance Measurement Period. Any amount owed by Seller to Buyer because of a WREGIS Certificate Deficit shall be made as an adjustment to Seller’s next monthly invoice to Buyer in accordance with Article 6, and Buyer shall net such amount against Buyer’s subsequent payment(s) to Seller pursuant to Article 6.

(vi) Without limiting Seller’s obligations under this Section 3.1(k), if a WREGIS Certificate Deficit is caused solely by an error or omission of WREGIS, the Parties shall cooperate in good faith to cause WREGIS to correct its error or omission.

(vii) If WREGIS changes the WREGIS Operating Rules after the Execution Date or applies the WREGIS Operating Rules in a manner inconsistent with this

Section 3.1(k) after the Execution Date, the Parties promptly shall modify this Section 3.1(k) as reasonably required to cause and enable Seller to transfer to Buyer's WREGIS Account a quantity of WREGIS Certificates for each given calendar month that corresponds to the Delivered Energy in the same calendar month.

(viii) Seller warrants that all necessary steps to allow the Renewable Energy Credits transferred to Buyer to be tracked in the Western Renewable Energy Generation Information System will be taken prior to the first delivery under the contract.

(l) Access to Data and Installation and Maintenance of Weather Station.

(i) Commencing on the first date on which the Project generates Product to be delivered to the CAISO Grid or the Delivery Point, if different, and continuing throughout the Term, Seller shall provide to Buyer, in a form reasonably acceptable to Buyer, the data set forth below on a real-time basis; provided that Seller shall agree to make and bear the cost of changes to any of the data delivery provisions below, as requested by Buyer, throughout the Term, which changes Buyer determines are necessary to forecast output from the Project:

(A) read-only access to meteorological measurements, transformer availability, any other facility availability information, and, if applicable, all parameters necessary for use in the equation under item (G) of this list;

(B) read-only access to energy output information collected by the supervisory control and data acquisition (SCADA) system for the Project; provided that if Buyer is unable to access the Project's SCADA system, then upon written request from Buyer, Seller shall provide energy output information and meteorological measurements to Buyer in 1-minute intervals in the form of a flat file to Buyer through a secure file transport protocol (FTP) system with an e-mail back up for each flat file submittal;

(C) read-only access to the Project's CAISO revenue meter and all Project meter data at the Site;

(D) full, real time access to the Project's Scheduling and Logging for the CAISO (SLIC) client application;

(E) net plant electrical output at the CAISO revenue meter;

(F) instantaneous data measurements at sixty (60) second or increased frequency for the parameters set forth in Appendix XV (Telemetry Parameters for Wind or Solar Facilities), which measurements shall be provided by Seller to Buyer in consolidated data report at least once every five minutes via flat file through a secure file transport protocol (FTP) system with an e-mail backup; and

(G) an equation, updated on an ongoing basis to reflect the potential generation of the Project as a function of wind speed, wind direction, ambient temperature, atmospheric pressure. Such equation shall take into account the expected availability of the generating facility.

For any month in which the above information and access was not available to Buyer for longer than twenty-four (24) continuous hours, Seller shall prepare and provide to Buyer upon Buyer's request a report with the Project's monthly Settlement Interval

Actual Available Capacity in the form set forth in Appendix XIV (“Actual Availability Report”). Upon Buyer’s request, Seller shall promptly provide to Buyer any additional and supporting documentation necessary for Buyer to audit and verify any matters set forth in the Actual Availability Report. Buyer shall exercise commercially reasonable efforts to notify Seller of any deficiency by Seller in meeting the requirements of this Section 3.1(l)(i); provided that any failure by Buyer to provide such deficiency notice shall not result in any additional liability to Buyer under this Agreement.

(ii) Buyer reserves the right to validate the data provided pursuant to Section 3.1(l)(i) with information publicly available from NOAA and nearby weather stations and substitute such data for its settlement purposes if Seller’s data is inconsistent with the publicly available data or is missing; provided that Buyer shall notify Seller promptly of Buyer’s substitution of such data.

(iii) Seller shall maintain at least a minimum of one hundred twenty (120) days’ historical data for all data required pursuant to Section 3.1(l)(i), which shall be available on a minimum time interval of one hour basis or an hourly average basis, except with respect to the meteorological measurements which shall be available on a minimum time interval of ten (10) minute basis. Seller shall provide such data to Buyer within five (5) Business Days of Buyer’s request.

(iv) Installation, Maintenance and Repair.

(A) Seller, at its own expense, shall install and maintain 3 stand-alone meteorological station(s) at the Site to monitor and report the meteorological data required in Section 3.1(l)(i) of this Agreement. Seller, at its own expense, shall install and maintain a secure communication link in order to provide Buyer with access to the data required in Section 3.1(l)(i) of this Agreement.

(B) Seller shall maintain the meteorological stations, telecommunications path, hardware, and software necessary to provide accurate data to Buyer or Third-Party SC (as applicable). Seller shall promptly repair and replace as necessary such meteorological stations, telecommunications path, hardware and software and shall notify Buyer as soon as Seller learns that any such telecommunications paths, hardware and software are providing faulty or incorrect data.

(C) If Buyer notifies Seller of the need for maintenance, repair or replacement of the meteorological stations, telecommunications path, hardware or software, Seller shall maintain, repair or replace such equipment as necessary within five (5) days of receipt of such Notice.

(D) For any occurrence in which Seller’s telecommunications system is not available or does not provide quality data and Buyer notifies Seller of the deficiency or Seller becomes aware of the occurrence, Seller shall transmit data to Buyer through any alternate means of communication (i.e., cellular communications from onsite personnel, facsimile, blackberry or equivalent mobile e-mail) until the telecommunications link is re-established.

(v) Seller agrees and acknowledges that Buyer may seek and obtain from third parties any information relevant to its duties as SC for Seller, including from the Participating Transmission Operator. Seller hereby voluntarily consents to allow the Participating

Transmission Operator to share Seller's information with Buyer in furtherance of Buyer's duties as SC for Seller, and agrees to provide the Participating Transmission Owner with written confirmation of such voluntary consent at least ninety (90) days prior to the Initial Energy Delivery Date.

(vi) No later than ninety (90) days before the Initial Energy Delivery Date, Seller shall provide one (1) year, if available, but no less than six (6) months, of recorded meteorological data to Buyer in a form reasonably acceptable to Buyer from a weather station at the Site. Such weather station shall provide, via remote access to Buyer, all data relating to (A) wind speed and direction, standard deviation of wind direction, air temperature, barometric pressure, and humidity at the Site, as well as time-average data including 10-minute and hourly values of irradiance or insolation, air temperature, wind speed, wind direction, standard deviation of wind direction, relative humidity, precipitation, and barometric pressure; (B) elevation, latitude and longitude of the weather station; and (C) any other data reasonably requested by Buyer.

(m) Prevailing Wage. (i) Seller shall use reasonable efforts to ensure that all Electricians hired by Seller, and its contractors and subcontractors are paid wages at rates not less than those prevailing for Electricians performing similar work in the locality as provided by Division 2, Part 7, Chapter 1 of the California Labor Code. Nothing herein shall require Seller, its contractors and subcontractors to comply with, or assume liability created by other inapplicable provisions of the California Labor Code. (ii) To the extent applicable, Seller shall comply with the prevailing wage requirements of California Public Utilities Code Section 399.14, subdivision (h).

(n) Obtaining and Maintaining CEC Certification and Verification. Seller shall take all necessary steps including, but not limited to, making or supporting timely filings with the CEC to obtain and maintain CEC Certification and Verification throughout the Term.

(o) Buyer Curtailment Requirements.

(i) Order and Limit. Buyer shall have the right to order Seller to reduce generation from the Project pursuant to a Buyer Curtailment Order or cause Seller to be required to reduce generation from the Project pursuant to a Buyer Bid Curtailment, provided that (A) a Buyer Curtailment Order shall be consistent with the operational characteristics set forth in Appendix XVI; and (B) Buyer shall pay Seller for Deemed Delivered Energy pursuant to Article 4. Seller agrees to reduce the Project's generation by the amount and for the period set forth in the Buyer Curtailment Order.

(ii) Failure to Comply. If Seller fails to comply with a Buyer Curtailment Order or Buyer Bid Curtailment provided in compliance with Section 3.1(o)(i), then, for each MWh of Delivered Energy that the Project generated in contradiction to the Buyer Curtailment Order or Buyer Bid Curtailment, Seller shall pay Buyer the greater of: (A) 200% of the Contract Price for such hours plus any penalties or other charges resulting from Seller's failure to comply with the Buyer Curtailment Order; or (B) the absolute value of the CAISO Real-Time Price for the applicable PNode for such hours plus any penalties or other charges resulting from Seller's failure to comply with the Buyer Curtailment Order or Buyer Bid Curtailment.

3.2 Green Attributes. Seller hereby provides and conveys all Green Attributes associated with all electricity generation from the Project to Buyer as part of the Product being delivered. Seller represents and warrants that Seller holds the rights to all Green Attributes from

the Project, and Seller agrees to convey and hereby conveys all such Green Attributes to Buyer as included in the delivery of the Product from the Project.

3.3 Resource Adequacy.

(a) During the Delivery Term, Seller grants, pledges, assigns and otherwise commits to Buyer all of the Project's Contract Capacity, including Capacity Attributes, from the Project to enable Buyer to meet its Resource Adequacy or successor program requirements, as the CPUC, CAISO or other regional entity may prescribe ("Resource Adequacy Requirements"). Seller agrees that during the Delivery Term Seller shall, at a minimum, comply with the terms set forth in Appendix X to enable Buyer to use all of the capacity, including Capacity Attributes, to be committed by Seller to Buyer pursuant to this Agreement to meet Buyer's Resource Adequacy Requirements. Compliance with the foregoing shall include Full Capacity Deliverability Status Finding by the CAISO.

(b) Seller shall be responsible for all costs, charges, expenses, penalties, and obligations resulting from Availability Standards, if applicable, and Seller shall be entitled to retain all credits, payments, and revenues, if any, resulting from Seller achieving or exceeding Availability Standards, if applicable.

(c) Buyer shall be responsible for all costs, charges, expenses, penalties, and obligations resulting from the Replacement Capacity Rules, if applicable, provided that Seller has given Buyer Notice of the outages subject to the Replacement Capacity Rules at least ninety (90) days before the first day of the month for which the outage will occur. If Seller fails to provide such Notice, then Seller shall be responsible for all costs, charges, expenses, penalties, and obligations resulting from the Replacement Capacity Rules for such outage.

(d) To the extent Seller has an exemption from the Availability Standards or the Replacement Capacity Rules under the CAISO Tariff, Sections 3.3(b) and 3.3(c) above shall not apply. If Seller would like to request an exemption for this Agreement from the CAISO, Seller shall provide to Buyer, as Seller's Scheduling Coordinator, Notice specifically requesting that Buyer seek certification or approval of this Agreement as an exempt contract pursuant to the CAISO Tariff; provided that Buyer's failure to obtain such exemption shall not be an Event of Default and Buyer shall not have any liability to Seller for such failure.

3.4 Transmission and Scheduling.

(a) Transmission.

(i) Seller's Transmission Service Obligations. As of the Test Period and during the Delivery Term:

(A) Seller shall arrange and pay independently for any and all necessary electrical interconnection, distribution and/or transmission (and any regulatory approvals required for the foregoing), sufficient to allow Seller to deliver the Product to the Delivery Point for sale pursuant to the terms of this Agreement. Seller's interconnection, distribution and/or transmission arrangements shall provide for Full Capacity Deliverability Status as of the Initial Delivery Date and throughout the Delivery Term.

(B) Seller shall bear all risks and costs associated with such transmission service, including, but not limited to, any transmission outages or curtailment to the Delivery Point.

(C) Seller shall fulfill all contractual, metering and applicable interconnection requirements, including those set forth in the Participating Transmission Owner's applicable tariffs, the CAISO Tariff and implementing CAISO standards and requirements, so as to be able to deliver Energy to the CAISO Grid.

(ii) Buyer's Transmission Service Obligations. Subject to Section 3.1(i)(ii) and Section 3.1(i)(iii), as of the Test Period and during the Delivery Term,

(A) Buyer shall arrange and be responsible for transmission service at and from the Delivery Point.

(B) Buyer shall bear all risks and costs associated with such transmission service, including, but not limited to, any transmission outages or curtailment from the Delivery Point.

(C) Buyer shall Schedule or arrange for Scheduling Coordinator services with its Transmission Providers to receive the Product at the Delivery Point.

(D) Buyer shall be responsible for all CAISO costs and charges, electric transmission losses and congestion at and from the Delivery Point.

(b) EIRP Requirements. Unless the Project is not EIRP-eligible or as otherwise directed by Buyer pursuant to Section 3.1(c)(E), (i) Seller shall provide Buyer with a copy of the notice from CAISO certifying the Project as a Participating Intermittent Resource as soon as practicable after Seller's receipt of such notice of certification, (ii) as of the first date of the Test Period and until the Project receives certification as a Participating Intermittent Resource, Seller, at its sole cost, shall comply with EIRP and additional protocols issued by the CAISO for Eligible Intermittent Resources, and (iii) throughout the Delivery Term, Seller, at its sole cost, shall participate in and comply with EIRP and all additional protocols issued by the CAISO for a Participating Intermittent Resource. If the EIRP is no longer made available by the CAISO or if Buyer directs Seller not to participate in such program, then throughout the Delivery Term, Seller, at its sole cost, shall participate in and comply with all other protocols, rules or regulations issued by the CAISO for generating facilities providing energy on an intermittent basis. Throughout the Delivery Term, Buyer in its limited capacity as Seller's Scheduling Coordinator shall facilitate communication with the CAISO and provide other administrative materials to CAISO as necessary to satisfy Seller's obligations as Seller's Scheduling Coordinator and to the extent such actions are at *de minimis* cost to Buyer.

(c) Scheduling Coordinator. Buyer shall act as the Scheduling Coordinator for the Project. In that regard, Buyer and Seller shall agree to the following:

(i) Designation as Scheduling Coordinator.

(A) At least ninety (90) days before the beginning of the Test Period Seller shall take all actions and execute and deliver to Buyer all documents necessary to authorize or designate Buyer, or Third-Party SC, as Seller's Scheduling Coordinator, and Buyer or Third-Party SC, as applicable, shall take all actions and execute and deliver to Seller or CAISO

all documents necessary to become and act as Seller's Scheduling Coordinator. If Buyer designates a Third-Party SC, then Buyer shall give Seller Notice of such designation at least ten (10) Business Days before the Third-Party SC assumes Scheduling Coordinator duties hereunder, and Seller shall be entitled to rely on such designation until it is revoked or a new Third-Party SC is appointed by Buyer upon similar Notice. Buyer shall be fully responsible for all acts and omissions of Third-Party SC and for all cost, charges and liabilities incurred by Third-Party SC to the same extent that Buyer would be responsible under this Agreement for such acts, omissions, costs, charges and liabilities if taken, omitted or incurred by Buyer directly.

(B) Seller shall not authorize or designate any other party to act as Scheduling Coordinator, nor shall Seller perform, for its own benefit, the duties of Scheduling Coordinator during the Test Period and Delivery Term.

(ii) Buyer's Responsibilities as Scheduling Coordinator. Buyer or Third-Party SC shall comply with all obligations as Seller's Scheduling Coordinator under the CAISO Tariff and shall conduct all Scheduling in full compliance with the terms and conditions of this Agreement and the applicable CAISO Tariff, all requirements of EIRP (if applicable) and protocols and scheduling practices for Energy on a Day-Ahead basis or pursuant to the Hour-Ahead Scheduling Process, as such terms are defined in the CAISO Tariff.

(iii) Available Capacity Forecasting. Seller shall provide the Available Capacity forecasts described below. Seller's availability forecasts below shall include Project availability and updated status of transformers, wind turbine unit status, and any other equipment that may impact availability. To avoid Forecasting Penalties set forth in Section 4.5(c)(ii), Seller shall use commercially reasonable efforts to forecast the Available Capacity of the Project accurately and to transmit such information in a format reasonably acceptable to Buyer. Buyer and Seller shall agree upon reasonable changes to the requirements and procedures set forth below from time-to-time, as necessary to comply with CAISO Tariff changes, accommodate changes to their respective generation technology and organizational structure and address changes in the operating and Scheduling procedures of Buyer, Third-Party SC (if applicable) and the CAISO, including but not limited to automated forecast and outage submissions.

(A) Annual Forecast of Available Capacity. No later than (I) the earlier of July 1 of the first calendar year following the Execution Date or one hundred and eighty (180) days before the first day of the first Contract Year of the Delivery Term ("First Annual Forecast Date"), if applicable, and (II) on or before July 1 of each calendar year for every subsequent Contract Year during the Delivery Term, Seller shall provide to Buyer and Third-Party SC (if applicable) a non-binding forecast of the hourly Available Capacity for each day in each month of the following calendar year in a form reasonably acceptable to Buyer.

(B) Monthly Forecast of Available Capacity. Ten (10) Business Days before the beginning of the Test Period, and thereafter ten (10) Business Days before the beginning of each month during the Delivery Term, Seller shall provide to Buyer and Third-Party SC (if applicable) a non-binding forecast of the hourly Available Capacity for each day of the following month in a form reasonably acceptable to Buyer.

(C) Daily Forecast of Available Capacity. During the Test Period and thereafter during the Delivery Term, Seller or Seller's agent shall provide a binding day ahead forecast of Available Capacity (the "Day-Ahead Availability Notice") to Buyer or Third-Party SC (as applicable) via Buyer's internet site, as provided in Appendix VIII, for each

day no later than fourteen (14) hours before the beginning of the “Preschedule Day” (as defined by the WECC) for such day. The current industry standard Preschedule Day timetable in the WECC is as follows:

- (1) Monday – Preschedule Day for Tuesday
- (2) Tuesday – Preschedule Day for Wednesday
- (3) Wednesday – Preschedule Day for Thursday
- (4) Thursday – Preschedule Day for Friday and Saturday
- (5) Friday – Preschedule Day for Sunday and Monday

Exceptions to this standard Monday through Friday Preschedule Day timetable are presently set forth by the WECC in order to accommodate holidays, monthly transitions and other events. Exceptions are posted on the WECC website (www.wecc.biz) under the document title, “Preschedule Calendar.” Each Day-Ahead Availability Notice shall clearly identify, for each hour, Seller’s forecast of all amounts of Available Capacity pursuant to this Agreement. If the Available Capacity changes by at least one (1) MW (AC) as of a time that is less than fourteen (14) hours prior to the Preschedule Day but prior to the CAISO deadline for Day-Ahead Schedules, then Seller must notify Buyer of such change by telephone and shall send a revised notice to Buyer’s Internet site set forth in Appendix VIII. Such Notices shall contain information regarding the beginning date and time of the event resulting in the change in Available Capacity, the expected end date and time of such event, the expected Available Capacity in MW (AC), and any other necessary information.

Day-Ahead Desk
Primary Telephone: (415) 973-6222
Backup Telephone: (415) 973-4500

If Seller fails to provide Buyer with a Day-Ahead Availability Notice as required herein, then, (I) until Seller provides a Day-Ahead Availability Notice, Buyer may rely on the most recent Day-Ahead Forecast of Available Capacity submitted by Seller to Buyer and Seller and (II) to the extent Seller’s failure contributes to an imbalance charge, Seller shall be subject to the Forecasting Penalties set forth in Section 4.5(c)(ii).

(D) Hourly Forecast of Available Capacity. During the Test Period and thereafter during the Delivery Term, Seller shall notify Buyer of any changes in Available Capacity of one (1) MW (AC) or more, whether due to Forced Outage, Force Majeure or other cause, as soon as reasonably possible, but no later than one (1) hour before Buyer or Third-Party SC (as applicable) is required to submit Schedules to the CAISO in accordance with the Hour-Ahead Scheduling Process. If the Available Capacity changes by at least one (1) MW as of a time that is less than one (1) hour prior to the Hour-Ahead Schedule Process deadline, but before such deadline, then Seller must likewise notify Buyer. Such Notices shall contain information regarding the beginning date and time of the event resulting in the change in Available Capacity, the expected end date and time of such event, the expected Available Capacity in MW (AC), and any other information required by the CAISO or reasonably requested by Buyer. With respect to any Forced Outage, Seller shall use commercially reasonable efforts to notify Buyer of such outage within ten (10) minutes of the commencement of the Forced Outage. Seller shall inform Buyer of any developments that will affect either the duration of such outage or the availability of the Project during or after the end of such outage. These notices and changes to Available Capacity shall be communicated by telephone to Buyer’s Real-Time Desk and shall be sent to Buyer’s internet site as set forth in Appendix VIII:

Real-Time Desk
Primary Telephone: (415) 973-4500

(iv) Replacement of Scheduling Coordinator.

(A) At least ninety (90) days prior to the end of the Delivery Term, or as soon as practicable before the date of any termination of this Agreement prior to the end of the Delivery Term, Seller shall take all actions necessary to terminate the designation of Buyer or the Third-Party SC, as applicable, as Seller's SC. These actions include (I) submitting to the CAISO a designation of a new SC for Seller to replace Buyer or the Third-Party SC (as applicable); (II) causing the newly-designated SC to submit a letter to the CAISO accepting the designation; and (III) informing Buyer and the Third-Party SC (if applicable) of the last date on which Buyer or the Third-Party SC (as applicable) will be Seller's SC.

(B) Buyer shall submit, or if applicable cause the Third-Party SC to submit, a letter to the CAISO identifying the date on which Buyer (or Third-Party SC, as applicable) resigns as Seller's SC on the first to occur of either (I) thirty (30) days prior to the end of the Delivery Term or (II) the date of any early termination of this Agreement.

3.5 Standards of Care.

(a) General Operation. Seller shall comply with all applicable requirements of Law, the CAISO, NERC and WECC relating to the Project (including those related to construction, ownership and/or operation of the Project).

(b) CAISO and WECC Standards. Each Party shall perform all generation, scheduling and transmission services in compliance with all applicable (i) operating policies, criteria, rules, guidelines, tariffs and protocols of the CAISO, (ii) WECC scheduling practices and (iii) Good Utility Practices.

(c) Reliability Standard. Seller agrees to abide by (i) CPUC General Order No. 167, "Enforcement of Maintenance and Operation Standards for Electrical Generating Facilities", and (ii) all applicable requirements regarding interconnection of the Project, including the requirements of the interconnected Participating Transmission Owner.

3.6 Metering. All output from the Project per the terms of this Agreement must be delivered through a single CAISO revenue meter and that meter must be dedicated exclusively to the Project described herein. All Product purchased under this Agreement must be measured by the Project's CAISO revenue meter to be eligible for payment under this Agreement. Seller shall bear all costs relating to all metering equipment installed to accommodate the Project. In addition, Seller hereby agrees to provide all meter data to Buyer in a form acceptable to Buyer, and consents to Buyer obtaining from the CAISO the CAISO meter data applicable to the Project and all inspection, testing and calibration data and reports. Seller shall grant Buyer the right to retrieve the meter reads from the CAISO Operational Meter Analysis and Reporting (OMAR) web and/or directly from the CAISO meter(s) at the Project site. If the CAISO makes any adjustment to any CAISO meter data for a given time period, Seller agrees that it shall submit revised monthly invoices, pursuant to Section 6.2, covering the entire applicable time period in order to conform fully such adjustments to the meter data. Seller shall submit any such revised invoice no later than thirty (30) days from the date on which the CAISO provides to Seller such binding adjustment to the meter data.

3.7 Outage Notification.

(a) CAISO Approval of Outage(s). Buyer is responsible for securing CAISO approvals for Project outages, including securing changes in its outage schedules when CAISO disapproves Buyer's schedules or cancels previously approved outages. Buyer shall put forth commercially reasonable efforts to secure and communicate CAISO approvals for Project outages in a timely manner to Seller. Buyer is responsible for entering Project outages in the Scheduling and Logging system for the CAISO (SLIC).

(b) Planned Outages. During the Delivery Term, Seller shall notify Buyer of its proposed Planned Outage schedule for the Project for the following calendar year by complying with the Annual Forecast of Available Capacity described in Section 3.4(c)(iii)(A) and implementing the notification procedures set forth in Appendix VIII no later than August 1st of each year during the Delivery Term. The Planned Outage schedule is subject to Buyer's approval, which approval may not be unreasonably withheld or conditioned. Seller shall also confirm or provide updates to Buyer regarding the Planned Outage no later than fourteen (14) days prior to each Planned Outage. Seller shall not conduct Planned Outages during the months of January, June through September, and December. During all other months, Seller shall not schedule Planned Outages without the prior written consent of Buyer, which consent may not be unreasonably withheld or conditioned. Seller shall contact Buyer with any requested changes to the Planned Outage schedule if Seller believes the Project must be shut down to conduct maintenance that cannot be delayed until the next scheduled Planned Outage consistent with Good Utility Practices. Seller shall not change its Planned Outage schedule without Buyer's approval, not to be unreasonably withheld or conditioned. Seller shall not substitute Energy from any other source for the output of the Project during a Planned Outage. Subject to Section 3.7(a), after any Planned Outage has been scheduled, at any time up to the commencement of work for the Planned Outage, Buyer may direct that Seller change its outage schedule as ordered by CAISO. For non-CAISO ordered changes to a Planned Outage schedule requested by Buyer, Seller shall notify Buyer of any incremental costs associated with such schedule change and an alternative schedule change, if any, that would entail lower incremental costs. If Buyer agrees to pay the incremental costs, Seller shall use commercially reasonable efforts to accommodate Buyer's request.

(c) Forced Outages. Seller shall notify Buyer of a Forced Outage within ten (10) minutes of the commencement of the Forced Outage and in accordance with the notification procedures set forth in Appendix VIII. Buyer shall put forth commercially reasonable efforts to submit such outages to CAISO.

(d) Prolonged Outages. Seller shall notify Buyer of a Prolonged Outage as soon as practicable in accordance with the notification provisions in Appendix VIII. Seller shall notify Buyer in writing when the Project is again capable of meeting its Contract Quantity on a *pro rata* basis also in accordance with the notification provisions in Appendix VIII. Seller shall not substitute Energy from any other source for the output of the Project during a Prolonged Outage.

(e) Force Majeure. Prior to the expiration of the of the second full Business Day subsequent to the commencement of an event of Force Majeure, the non-performing Party shall provide the other Party with oral notice of the event of Force Majeure, and within two (2) weeks of the commencement of an event of Force Majeure the non-performing Party shall provide the other Party with Notice in the form of a letter describing in detail the particulars of the occurrence giving rise to the Force Majeure claim. Failure to provide timely Notice

constitutes a waiver of a Force Majeure claim. Seller shall not substitute Products from any other source for the output of the Project during an outage resulting from Force Majeure. The suspension of performance due to a claim of Force Majeure must be of no greater scope and of no longer duration than is required by the Force Majeure. Buyer shall not be required to make any payments for any Products that Seller fails to deliver or provide as a result of Force Majeure during the term of a Force Majeure.

(f) Communications with CAISO. Buyer or Third-Party SC, in coordination with Seller, shall be responsible for all outage coordination communications with CAISO outage coordination personnel and CAISO operations management, including submission to CAISO of updates of outage plans, submission of clearance requests, and all other outage-related communications.

(g) Changes to Operating Procedures. Notwithstanding any language to the contrary contained in Sections 3.4, 3.6, 3.7 or 3.8 or Appendix VIII, Seller understands and acknowledges that the specified access to data and installation and maintenance of weather stations, transmission and scheduling mechanisms, metering requirements, Outage Notification Procedures and operating procedures described in the above-referenced sections are subject to change by Buyer from time to time and, upon receipt of Notice of any such changes, Seller agrees to work in good faith to implement any such changes as reasonably deemed necessary by Buyer; provided that such change does not result in an increase cost of performance to Seller hereunder other than *de minimis* amounts.

3.8 Operations Logs and Access Rights.

(a) Operations Logs. Seller shall maintain a complete and accurate log of all material operations and maintenance information on a daily basis. Such log shall include, but not be limited to, information on power production, efficiency, availability, maintenance performed, outages, results of inspections, manufacturer recommended services, replacements, electrical characteristics of the generators, control settings or adjustments of equipment and protective devices. Seller shall provide this information electronically to Buyer within thirty (30) days of Buyer's request.

(b) Access Rights. Buyer, its authorized agents, employees and inspectors shall have the right of ingress to and egress from the Project on reasonable advance notice during normal business hours and for any purposes reasonably connected with this Agreement or the exercise of any and all rights secured to Buyer by Law, or its tariff schedules, PG&E Interconnection Handbook, Electric Rule 21 (if PG&E is the Participating Transmission Owner), and rules on file with the CPUC. Buyer shall make reasonable efforts to coordinate its emergency activities with the Safety and Security Departments, if any, of the Project operator. Seller shall keep Buyer advised of current procedures for contacting the Project operator's Safety and Security Departments.

3.9 New Generation Facility.

- (a) Seller, at no cost to Buyer, shall be responsible to:
- (i) Design and construct the Project.

(ii) Perform all studies, pay all fees, obtain all necessary approvals and execute all necessary agreements to secure the interconnection and transmission arrangements required pursuant to Section 3.4(a)(i).

(iii) Acquire all permits and other approvals necessary for the construction, operation, and maintenance of the Project.

(iv) Complete all environmental impact studies necessary for the construction, operation, and maintenance of the Project.

(v) At Buyer's request, provide to Buyer Seller's electrical specifications and design drawings pertaining to the Project for Buyer's review prior to finalizing design of the Project and before beginning construction work based on such specifications and drawings. Seller shall provide to Buyer reasonable advance Notice of any changes in the Project and provide to Buyer specifications and design drawings of any such changes.

(vi) Within fifteen (15) days after the close of each month from the first month following the Execution Date until the Commercial Operation Date, provide to Buyer a Monthly Progress Report and agree to regularly scheduled meetings between representatives of Buyer and Seller to review such monthly reports and discuss Seller's construction progress. The Monthly Progress Report shall indicate whether Seller has met or is on target to meet the Milestones.

(vii) Provide to Buyer a copy of the Final Output Report, and any updates thereafter for the time period beginning on the Effective Date and ending on the last day of the first Contract Year, as applicable.

(b) Buyer shall have the right, but not the obligation, to:

(i) Notify Seller in writing of the results of the review within thirty (30) days of Buyer's receipt of all specifications for the Project, including a description of any flaws perceived by Buyer in the design.

(ii) Inspect the Project's construction site or on-site Seller data and information pertaining to the Project during business hours upon reasonable notice.

(c) Construction Milestones.

(i) Milestones. The Parties agree time is of the essence in regards to the Agreement. As such, the Parties also agree certain Milestones must be achieved in a timely fashion or Buyer will suffer damages. Seller shall provide Buyer with any requested documentation to support the achievement of Milestones within ten (10) Business Days of receipt of such request by Seller.

(ii) Remedial Action Plan. If Seller misses three (3) or more Milestones, other than a Guaranteed Project Milestone, or misses any one (1) by more than ninety (90) days, except as the result of Force Majeure, Seller shall submit to Buyer, within ten (10) Business Days of such missed Milestone completion date, a remedial action plan ("Remedial Action Plan"), which is outlined in the Monthly Progress Report and requires Seller to provide a detailed description of its proposed course of action to achieve the missed Milestones and all subsequent Milestones by the Guaranteed Commercial Operation Date; provided, that delivery of

any Remedial Action Plan shall not relieve Seller of its obligation to meet any subsequent Milestones and the Guaranteed Commercial Operation Date. If the missed Milestone(s) is a Guaranteed Project Milestone, then subsection (iv) below shall apply.

(iii) Guaranteed Project Milestones. “Guaranteed Project Milestones” are as follows:

(A) The Construction Start Date shall occur no later than July 1, 2012 (the “Guaranteed Construction Start Date”); provided that the Guaranteed Construction Start Date may be extended on a day for day basis for not more than:

(I) Intentionally omitted;

(II) Intentionally omitted;

(III) three hundred sixty (360) days in the event of Force Majeure (“Force Majeure Construction Extension”); provided that Seller works diligently to resolve the effect of the Force Majeure and provides evidence of its efforts promptly to Buyer upon Buyer’s written request; or

(B) Intentionally omitted

(C) Seller shall have demonstrated Commercial Operation per the terms of Appendix VI no later than December 31, 2012 (the “Guaranteed Commercial Operation Date”), provided that (I) the Guaranteed Commercial Operation Date may be extended on a day for day basis equal to any extension claimed by Seller pursuant to and in accordance with Section 3.9(c)(iii)(A), and (II) the Guaranteed Commercial Operation Date may be extended further on a day for day basis for Force Majeure occurring after the Construction Start Date provided that the total number of such extension days shall not exceed three hundred sixty (360) days.

(D) If Seller claims a Permitted Extension, Seller shall provide Buyer with sixty (60) days Notice prior to original date of the applicable Guaranteed Project Milestone, which Notice must clearly identify the Permitted Extension being claimed and include information necessary for Buyer to verify the length and qualification of the extension; provided that in the case of a Force Majeure Construction Extension, if sixty (60) days is impracticable or impossible, Seller shall provide Notice as soon as possible after the occurrence of the Force Majeure event.

(iv) Cure Period and Delay Damages.

(A) Seller shall cause the Project to achieve the Commercial Operation Date by the Guaranteed Commercial Operation Date; provided, however, that the Commercial Operation Date shall not occur more than one hundred eighty (180) days prior to the Guaranteed Commercial Operation Date. If (I) the Commercial Operation Date occurs after the Guaranteed Commercial Operation Date after giving effect to Permitted Extensions or Force Majeure after Construction Start Date or (II) the Construction Start Date occurs after the Guaranteed Construction Start Date after giving effect to Permitted Extensions, then Buyer shall be entitled to draw upon the Project Development Security for liquidated damages equal to Daily Delay Damages for each day or portion of a day that (1) the Commercial Operation Date occurs after the Guaranteed Commercial Operation Date after giving effect to Permitted Extensions for

up to a total of sixty (60) days (“Project Cure Period”); or (2) the Construction Start Date occurs after the Guaranteed Construction Start Date after giving effect to Permitted Extensions for up to a total of sixty (60) days (“Construction Cure Period”). The Parties agree that Buyer’s receipt of Daily Delay Damages shall (x) not be construed as Buyer’s declaration that an Event of Default has occurred under any provision of Section 5.1 and (y) not limit Buyer’s right to receive a Termination Payment or Damage Payment, as applicable, upon exercise of Buyer’s default right pursuant to Section 5.2.

(B) Each Party agrees and acknowledges that (I) the damages that Buyer would incur due to Seller’s delay in achieving either of the Guaranteed Project Milestones would be difficult or impossible to predict with certainty, and (II) the Daily Delay Damages are an appropriate approximation of such damages. Seller shall be entitled to the return of all Daily Delay Damages collected by Buyer as a result of Seller’s failure to meet the Guaranteed Construction Start Date only if Seller meets the Guaranteed Commercial Operation Date (as may be extended by Permitted Extensions) as provided further in Section 8.4(c) of this Agreement. For sake of certainty, Buyer shall retain all Daily Delay Damages drawn (or which Buyer is entitled to draw) as a result of Seller’s failure to meet the Guaranteed Commercial Operation Date and the Guaranteed Construction Start Date (both as may be extended by Permitted Extensions), if Seller fails to meet the Guaranteed Commercial Operation Date (as may be extended by Permitted Extensions).

(C) The Parties agree that prior to the Commercial Operation Date Seller may elect to reduce the Contract Capacity to not less than 90 MW. If Seller elects to reduce the Contract Capacity, then at least five (5) Business Days prior to the Commercial Operation Date Seller shall (I) provide Buyer a Capacity Reduction Notice in the form set forth in Appendix XX, and provide the statements required in Appendix VI-2 informing Buyer of the reduced Contract Capacity, which shall equal the aggregate nameplate capacity of the Units that are or will be operating as of Commercial Operation net of all auxiliary loads, station electrical uses, and Electrical Losses, and (II) pay to Buyer prior to the Commercial Operation Date, as liquidated damages and not as a penalty, an amount equal to the product of (x) the excess, in MW, of the Contract Capacity specified in Section 3.1(f) over the reduced Contract Capacity, multiplied by (y) fifty thousand dollars (\$50,000.00). The Parties agree that the Contract Quantity and Delivery Term Security shall be reduced on a pro rata basis to correspond to the reduced Contract Capacity and the reduced amounts for each shall be set forth in the Capacity Reduction Notice. Additionally, if the liquidated damages set forth in this Section 3.9(c)(iv)(C) are due and Seller fails to make such payment by the Commercial Operation Date, then Seller shall be subject to an Event of Default pursuant to Section 5.1(a) of this Agreement for failure to pay. Each Party agrees and acknowledges that the damages that Buyer would incur due to Seller’s inability to bring the full Contract Capacity into operation would be difficult or impossible to predict with certainty, and the foregoing liquidated damages amount is an appropriate approximation of such damages. Seller’s payment of such damages shall be Seller’s sole obligation and Buyer’s sole remedy with respect to any failure to achieve Commercial Operation at a Contract Capacity of less than 100 MW.

ARTICLE FOUR: COMPENSATION; MONTHLY PAYMENTS

4.1 Price.

(a) Contract Price. The Contract Price for each MWh of Product as measured by Delivered Energy in each Contract Year shall be as follows:

Contract Year	Contract Price (\$/MWh)
1-25	\$90.00/MWh

(b) Deemed Delivered Energy Price. During a Buyer Curtailment Period, the Deemed Delivered Energy Price shall be the Contract Price.

4.2 Intentionally omitted.

4.3 Intentionally omitted.

4.4 Excess Delivered and Deemed Delivered Energy. In any Contract Year, if the amount of Delivered Energy plus the amount of Deemed Delivered Energy exceeds one hundred twenty percent (120%) of the annual Contract Quantity amount (“Excess Energy”), Seller shall refund to Buyer an amount equal to the product of the Excess Energy multiplied by twenty-five percent (25%) of the applicable Contract Price or Deemed Delivered Energy Price for such Contract Year.

4.5 CAISO Charges.

(a) Seller shall assume all liability and reimburse Buyer for any and all CAISO Penalties incurred by Buyer because of Seller’s failure to perform any covenant or obligation set forth in this Agreement. Buyer shall assume all liability and reimburse Seller for any and all CAISO Penalties incurred by Seller as a result of Buyer’s actions, including those resulting in a Buyer Curtailment Period.

(b) Buyer shall be responsible for all costs and charges assessed by the CAISO with respect to Scheduling and imbalances except as provided in Section 4.5(c) below. Seller and Buyer shall cooperate to minimize such charges and imbalances to the extent possible. Seller shall use commercially reasonable efforts to monitor imbalances and shall promptly notify Buyer as soon as possible after it becomes aware of any material imbalance that is occurring or has occurred. Such notification shall not alter Seller’s and Buyer’s respective responsibilities for payment for imbalance and congestion charges and CAISO Penalties under this Agreement. Throughout the Delivery Term, Buyer shall be entitled to all Integrated Forward Market Load Uplift Obligation credits (as defined or required for MRTU under the CAISO Tariff) associated with the Energy generated from the Project.

(c) Forecasting Penalties.

(i) Subject to Force Majeure, in the event Seller does not in a given hour either (A) provide the access and information required in Section 3.1(l)(i); (B) comply with the installation, maintenance and repair requirements of Section 3.1(l)(iv); or (C) provide the forecast of Available Capacity required in Section 3.4(c)(iii), and the sum of Energy Deviations for each of the six Settlement Intervals in the given hour exceeded the Performance Tolerance Band defined below, then Seller will be responsible for Forecasting Penalties as set forth below.

(ii) The Performance Tolerance Band is three percent (3%) multiplied by Contract Capacity multiplied by one (1) hour.

(iii) Forecasting Penalties. The Forecasting Penalty shall be equal to the greater of (A) one hundred fifty percent (150%) of the Contract Price or (B) the Real Time

Price, in each case for each MWh of Energy Deviation outside the Performance Tolerance Band, or any portion thereof, in every hour for which Seller fails to meet the requirements in Section 4.5(c)(i). Settlement of Forecasting Penalties shall occur as set forth in Section 6.1 of this Agreement.

4.6 Test Period Payments. During the Test Period Seller's full compensation for Product sold to Buyer shall be the CAISO Revenues for the Delivered Energy, which revenues Buyer shall forward promptly to Seller in accordance with the schedule described in Section 6.1.

4.7 Additional Compensation.

(a) To the extent not otherwise provided for in this Agreement, in the event that Seller is compensated by a third party for any Products produced by the Project, including, but not limited to, compensation for Resource Adequacy or Green Attributes, Seller shall remit all such compensation directly to Buyer; provided that for avoidance of doubt, nothing herein precludes Seller from retaining credits related to Electric System Upgrades contemplated in Section 3.1(h)(i).

(b) To the extent that during the Delivery Term Seller (at a nominal or no cost to Seller) is exempt from, reimbursed for or receives any refunds, credits or benefits from CAISO for congestion charges or Congestion Revenue Rights (as defined in the CAISO Tariff), whether due to any adjustments in Congestion Revenue Rights or any Locational Marginal Price (as defined in the CAISO Tariff), market adjustments, invoice adjustments, or any other hedging instruments associated with the Product (collectively, any such refunds, credits or benefits are referred to as "Reductions"), then, at Buyer's option, either (i) Seller shall transfer any such Reductions and their related rights to Buyer less any costs incurred by Seller in connection with such Reductions; or (ii) Buyer shall reduce payments due to Seller under this Agreement in amounts equal to the Reductions less any costs incurred by Seller in connection with such Reduction and Seller shall retain the Reductions.

ARTICLE FIVE: EVENTS OF DEFAULT; PERFORMANCE REQUIREMENT; REMEDIES

5.1 Events of Default. An "Event of Default" shall mean,

(a) with respect to a Party that is subject to the Event of Default, the occurrence of any of the following:

(i) the failure to make, when due, any payment required pursuant to this Agreement if such failure is not remedied within five (5) Business Days after written Notice is received by the Party failing to make such payment;

(ii) any representation or warranty made by such Party herein (A) is false or misleading in any material respect when made or (B) with respect to Section 10.2(b), becomes false or misleading in any material respect during the Delivery Term; provided that, if a change in Law occurs after the Execution Date that causes the representation and warranty made by Seller in Section 10.2(b) to be materially false or misleading, such breach of the representation or warranty in Section 10.2(b) shall not be an Event of Default if Seller has used commercially reasonable efforts to comply with such change in Law during the Delivery Term in order to make the representation and warranty no longer false or misleading;

(iii) the failure to perform any material covenant or obligation set forth in this Agreement (except to the extent constituting a separate Event of Default), if such failure is not remedied within thirty (30) days after Notice;

(iv) such Party becomes Bankrupt; or

(v) such Party consolidates or amalgamates with, or merges with or into, or transfers all or substantially all of its assets to, another entity and, at the time of such consolidation, amalgamation, merger or transfer, the resulting, surviving or transferee entity fails to assume all the obligations of such Party under this Agreement to which it or its predecessor was a party by operation of Law or pursuant to an agreement reasonably satisfactory to the other Party.

(b) with respect to Seller as the Defaulting Party, the occurrence of any of the following:

(i) if at any time during the Term of this Agreement, Seller delivers or attempts to deliver to the Delivery Point for sale under this Agreement Energy that was not generated by the Project;

(ii) failure by Seller to meet the Guaranteed Construction Start Date as extended by any Permitted Extensions, and after the applicable cure period has expired due solely to Seller's inability to obtain, after the use of commercially reasonable efforts, any of the following in time to achieve the Guaranteed Construction Start Date: (A) permits necessary to construct or operate the Project, or (B) an LGIA that provides for the Project being physically interconnected to the CAISO Grid and for the completion of any necessary Electric System Upgrades;

(iii) failure by Seller to meet the Guaranteed Commercial Operation Date as extended by any Permitted Extensions, and after the applicable cure period has expired due solely to Seller's inability to achieve, after the use of commercially reasonable efforts, by the Guaranteed Commercial Operation Date either the physical interconnection of the Project to the CAISO or any necessary Electric System Upgrades;

(iv) failure by Seller for any reason other than those explicitly provided in Sections 5.1(b)(ii) and (iii) above and Section 11.2(a)(ii) to meet either of the Guaranteed Project Milestones as may be extended by Permitted Extensions and in each case after the applicable cure period has expired;

(v) failure by Seller to satisfy the creditworthiness/collateral requirements agreed to pursuant to Sections 8.3, 8.4, or 8.5 of this Agreement;

(vi) failure by Seller to achieve the Guaranteed Energy Production requirement as set forth in Section 3.1(e)(ii) of this Agreement as follows:

(A) after the one (1) year GEP Cure period Seller has failed to cure the GEP Failure and has failed to pay GEP Damages in the time period set forth in Section 3.1(e)(ii); or

(B) if, after any Performance Measurement Period the cumulative GEP Shortfall for all Performance Measurement Periods occurring during the

Delivery Term equals or exceeds the Contract Quantity; provided, however, that if all or a portion of a GEP Shortfall during an applicable Performance Measurement Period is principally caused by a non-Force Majeure major equipment malfunction, breakdown, or failure resulting in a reduction of Energy production of the Project by at least sixty percent (60%) of the Contract Quantity in one or both years of the Performance Measurement Period, as applicable, and such malfunction, breakdown, or failure was not caused by Seller and could not have been avoided through the exercise of Good Utility Practice, such failure shall be excluded from the calculation of the cumulative GEP Shortfall for purposes of this subsection.

5.2 Declaration of Early Termination Date. If an Event of Default with respect to a Defaulting Party shall have occurred and is continuing, the other Party (“Non-Defaulting Party”) shall have the following rights:

(a) send Notice, designating a day, no earlier than the day such Notice is deemed to be received and no later than twenty (20) days after such Notice is deemed to be received, as an early termination date of this Agreement (“Early Termination Date”) on which to (i) collect the Damage Payment in accordance with Section 5.8 below, if the Event of Default arose under Sections 5.1(b)(ii) or Section 5.1(b)(iii), or (ii) collect the Termination Payment for any other Event of Default;

(b) accelerate all amounts owing between the Parties, terminate the Transaction and end the Delivery Term effective as of the Early Termination Date;

(c) withhold any payments due to the Defaulting Party under this Agreement;

(d) suspend performance;

(e) exercise its rights pursuant to Section 8.3 to draw upon and retain Performance Assurance; and

(f) exercise any other rights or remedies available at Law or in equity to the extent otherwise permitted under this Agreement.

5.3 Calculation of Termination Payment.

(a) The Non-Defaulting Party shall calculate, in a commercially reasonable manner, a Settlement Amount for the Terminated Transaction as of the Early Termination Date. Third parties supplying information for purposes of the calculation of Gains or Losses may include, without limitation, dealers in the relevant markets, end-users of the relevant product, information vendors and other sources of market information. If the Non-Defaulting Party uses the market price for a comparable transaction to determine the Gains or Losses, such price should be determined by using the average of market quotations provided by three (3) or more bona fide unaffiliated market participants. If the number of available quotes is three, then the average of the three quotes shall be deemed to be the market price. Where a quote is in the form of bid and ask prices, the price that is to be used in the averaging is the midpoint between the bid and ask price. The quotes obtained shall be: (a) for a like amount, (b) of the same Product, (c) at the same Delivery Point, (d) for the remaining Delivery Term, and (e) any other commercially reasonable manner.

(b) If the Non-Defaulting Party's aggregate Gains exceed its aggregate Losses and Costs, if any, resulting from the termination of the Terminated Transaction, the Settlement Amount shall be zero.

(c) The Non-Defaulting Party shall not have to enter into replacement transactions to establish a Settlement Amount.

5.4 Notice of Payment of Termination Payment. As soon as practicable after a liquidation, Notice shall be given by the Non-Defaulting Party to the Defaulting Party of the amount of the Termination Payment and whether the Termination Payment is due to the Non-Defaulting Party. The Notice shall include a written statement explaining in reasonable detail the calculation of such amount and the sources for such calculation. The Termination Payment shall be made to the Non-Defaulting Party, as applicable, within ten (10) Business Days after such Notice is effective.

5.5 Disputes With Respect to Termination Payment. If the Defaulting Party disputes the Non-Defaulting Party's calculation of the Termination Payment, in whole or in part, the Defaulting Party shall, within five (5) Business Days of receipt of the Non-Defaulting Party's calculation of the Termination Payment, provide to the Non-Defaulting Party a detailed written explanation of the basis for such dispute. Disputes regarding the Termination Payment shall be determined in accordance with Article Twelve.

5.6 Rights And Remedies Are Cumulative. The rights and remedies of a Party pursuant to this Article Five shall be cumulative and in addition to the rights of the Parties otherwise provided in this Agreement.

5.7 Duty to Mitigate. Buyer and Seller shall each have a duty to mitigate damages pursuant to this Agreement, and each shall use reasonable efforts to minimize any damages it may incur as a result of the other Party's non-performance of this Agreement, including with respect to termination of this Agreement.

5.8 Damage Payment for Failure to Achieve Guaranteed Dates. The Parties agree that the Damage Payment to be paid by Seller for an Event of Default arising under Section 5.1(b)(ii) or Section 5.1(b)(iii) associated with Seller's failure to achieve the Guaranteed Construction Start Date or Guaranteed Commercial Operation Date shall be considered liquidated damages and not a penalty, in accordance with Section 7.1.

ARTICLE SIX: PAYMENT

6.1 Billing and Payment; Remedies. On or about the tenth (10th) day of each month beginning with the second month of either the Test Period or the first Contract Year, whichever occurs first, and every month thereafter, and continuing through and including the first month following the end of the Delivery Term, Seller shall provide to Buyer (a) records of metered data, including CAISO metering and transaction data sufficient to document and verify the generation of Product by the Project for any CAISO settlement time interval during the preceding months, (b) access to any records, including invoices or settlement data from the CAISO, necessary to verify the accuracy or amount of any Reductions; and (c) an invoice, in the format specified by Buyer, covering the services provided in the preceding month as adjusted pursuant to Section 4.5 (CAISO Charges) (which may include charges incurred in preceding months), and, if applicable, Section 4.6. Seller shall continue to provide to Buyer an invoice of CAISO charges, net any sums Buyer owes Seller under this Agreement, on or about the tenth (10th) day of each month until the

date of the Final True-Up. Buyer shall pay the undisputed amount of such invoices less the amount of any Forecasting Penalties (as applicable), on or before the later of the twenty-fifth (25th) day of each month and fifteen (15) days after receipt of the invoice. If either the invoice date or payment date is not a Business Day, then such invoice or payment shall be provided on the next following Business Day. Each Party will make payments by electronic funds transfer, or by other mutually agreeable method(s), to the account designated by the other Party. Any undisputed amounts not paid by the due date will be deemed delinquent and will accrue interest at the Interest Rate, such interest to be calculated from and including the due date to but excluding the date the delinquent amount is paid in full. Invoices may be sent by facsimile or e-mail.

6.2 Disputes and Adjustments of Invoices. In the event an invoice or portion thereof or any other claim or adjustment arising hereunder, is disputed, payment of the undisputed portion of the invoice shall be required to be made when due, with Notice of the objection given to the other Party. Any invoice dispute or invoice adjustment shall be in writing and shall state the basis for the dispute or adjustment. Payment of the disputed amount shall not be required until the dispute is resolved. Subject to Section 3.6, in the event adjustments to payments are required as a result of inaccurate meter(s), Buyer shall use corrected measurements to recompute the amount due from Buyer to Seller for the Product delivered under the Transaction during the period of inaccuracy. The Parties agree to use good faith efforts to resolve the dispute or identify the adjustment as soon as possible. Upon resolution of the dispute or calculation of the adjustment, any required payment shall be made within fifteen (15) days of such resolution along with interest accrued at the Interest Rate from and including the due date, but excluding the date paid. Inadvertent overpayments shall be returned upon request or deducted by the Party receiving such overpayment from subsequent payments, with interest accrued at the Interest Rate from and including the date of such overpayment, but excluding the date repaid or deducted by the Party receiving such overpayment. Any dispute with respect to an invoice is waived unless the other Party is notified in accordance with this Section 6.2 within twelve (12) months after the invoice is rendered or any specific adjustment to the invoice is made. If an invoice is not rendered within twelve (12) months after the close of the month during which performance under the Transaction occurred, the right to payment for such performance is waived.

ARTICLE SEVEN: LIMITATIONS

7.1 Limitation of Remedies, Liability and Damages. THE PARTIES CONFIRM THAT THE EXPRESS REMEDIES AND MEASURES OF DAMAGES PROVIDED IN THIS AGREEMENT SATISFY THE ESSENTIAL PURPOSES HEREOF.

FOR BREACH OF ANY PROVISION FOR WHICH AN EXPRESS REMEDY OR MEASURE OF DAMAGES IS PROVIDED, SUCH EXPRESS REMEDY OR MEASURE OF DAMAGES SHALL BE THE SOLE AND EXCLUSIVE REMEDY, THE OBLIGOR'S LIABILITY SHALL BE LIMITED AS SET FORTH IN SUCH PROVISION AND ALL OTHER REMEDIES OR DAMAGES AT LAW OR IN EQUITY ARE WAIVED, UNLESS THE PROVISION IN QUESTION PROVIDES THAT THE EXPRESS REMEDIES ARE IN ADDITION TO OTHER REMEDIES THAT MAY BE AVAILABLE.

IF NO REMEDY OR MEASURE OF DAMAGES IS EXPRESSLY PROVIDED HEREIN, THE OBLIGOR'S LIABILITY SHALL BE LIMITED TO DIRECT ACTUAL DAMAGES ONLY, SUCH DIRECT ACTUAL DAMAGES SHALL BE THE SOLE AND EXCLUSIVE REMEDY AND ALL OTHER REMEDIES OR DAMAGES AT LAW OR IN EQUITY ARE WAIVED UNLESS EXPRESSLY HEREIN PROVIDED. NEITHER PARTY SHALL BE LIABLE FOR CONSEQUENTIAL, INCIDENTAL, PUNITIVE, EXEMPLARY OR INDIRECT DAMAGES,

LOST PROFITS OR OTHER BUSINESS INTERRUPTION DAMAGES, BY STATUTE, IN TORT OR CONTRACT, UNDER ANY INDEMNITY PROVISION OR OTHERWISE EXCEPT TO THE EXTENT PART OF AN EXPRESS REMEDY OR MEASURE OF DAMAGES HEREIN.

UNLESS EXPRESSLY HEREIN PROVIDED, AND SUBJECT TO THE PROVISIONS OF SECTION 10.5 (INDEMNITIES), IT IS THE INTENT OF THE PARTIES THAT THE LIMITATIONS HEREIN IMPOSED ON REMEDIES AND THE MEASURE OF DAMAGES BE WITHOUT REGARD TO THE CAUSE OR CAUSES RELATED THERETO, INCLUDING THE NEGLIGENCE OF ANY PARTY, WHETHER SUCH NEGLIGENCE BE SOLE, JOINT OR CONCURRENT, OR ACTIVE OR PASSIVE.

TO THE EXTENT ANY DAMAGES REQUIRED TO BE PAID HEREUNDER ARE LIQUIDATED, THE PARTIES ACKNOWLEDGE THAT THE DAMAGES ARE DIFFICULT OR IMPOSSIBLE TO DETERMINE, OR OTHERWISE OBTAINING AN ADEQUATE REMEDY IS INCONVENIENT AND THE DAMAGES CALCULATED HEREUNDER CONSTITUTE A REASONABLE APPROXIMATION OF THE HARM OR LOSS.

ARTICLE EIGHT: CREDIT AND COLLATERAL REQUIREMENTS

8.1 Buyer Financial Information. If requested by Seller, Buyer shall deliver to Seller (a) within one hundred twenty (120) days after the end of each fiscal year with respect to PG&E Corporation, a copy of PG&E Corporation's annual report containing audited consolidated financial statements for such fiscal year and (b) within sixty (60) days after the end of each of PG&E Corporation's first three fiscal quarters of each fiscal year, a copy of PG&E Corporation's quarterly report containing unaudited consolidated financial statements for each accounting period prepared in accordance with Generally Accepted Accounting Principles. Buyer shall be deemed to have satisfied such delivery requirement if the applicable report is publicly available on www.pge-corp.com or on the SEC EDGAR information retrieval system; provided however, that should such statements not be available on a timely basis due to a delay in preparation or certification, such delay shall not be an Event of Default, so long as such statements are provided to Seller upon their completion and filing with the SEC.

8.2 Seller Financial Information. If requested by Buyer, Seller shall deliver to Buyer (a) within one hundred twenty (120) days following the end of each fiscal year, a copy of Seller's annual report containing unaudited consolidated financial statements for such fiscal year (or audited consolidated financial statements for such fiscal year if otherwise available) and (b) within sixty (60) days after the end of each of its first three fiscal quarters of each fiscal year, a copy of such Party's quarterly report containing unaudited consolidated financial statements for such fiscal quarter. In all cases the statements shall be for the most recent accounting period and shall be prepared in accordance with Generally Accepted Accounting Principles; provided, however, that should any such statements not be available on a timely basis due to a delay in preparation or certification, such delay shall not be an Event of Default so long as such Party diligently pursues the preparation, certification and delivery of the statements.

8.3 Grant of Security Interest/Remedies. To secure its obligations under this Agreement and to the extent Seller delivers the Project Development Security or Delivery Term Security, as applicable, hereunder, Seller hereby grants to Buyer, as the secured party, a first priority security interest in, and lien on (and right of setoff against), and assignment of, all such Performance Assurance posted with Buyer in the form of cash collateral and cash equivalent collateral and any and all proceeds resulting therefrom or the liquidation thereof, whether now or

hereafter held by, on behalf of, or for the benefit of, Buyer. Within thirty days of the delivery of the Project Development Security or Delivery Term Security, as applicable, Seller agrees to take such action as Buyer reasonably requires in order to perfect a first-priority security interest in, and lien on (and right of setoff against), such Performance Assurance and any and all proceeds resulting therefrom or from the liquidation thereof. Upon or any time after the occurrence or deemed occurrence and during the continuation of an Event of Default or an Early Termination Date, Buyer, as the Non-Defaulting Party, may do any one or more of the following: (a) exercise any of the rights and remedies of a secured party with respect to all Project Development Security or Delivery Term Security, as applicable, including any such rights and remedies under the Law then in effect; (b) exercise its rights of setoff against any and all property of Seller, as the Defaulting Party, in the possession of the Buyer or Buyer's agent; (c) draw on any outstanding Letter of Credit issued for its benefit; and (d) liquidate all Project Development Security or Delivery Term Security, as applicable, then held by or for the benefit of Buyer free from any claim or right of any nature whatsoever of Seller, including any equity or right of purchase or redemption by Seller. Buyer shall apply the proceeds of the collateral realized upon the exercise of any such rights or remedies to reduce Seller's obligations under the Agreement (Seller remaining liable for any amounts owing to Buyer after such application), subject to the Buyer's obligation to return any surplus proceeds remaining after such obligations are satisfied in full.

8.4 Performance Assurance.

(a) Project Development Security; Delivery Term Security. Seller agrees to deliver to Buyer collateral to secure its obligations under this Agreement, which Seller shall maintain in full force and effect for the period posted with Buyer, as follows:

(i) Project Development Security pursuant to this Section 8.4(a)(i) in the amount of one million five hundred thousand dollars (\$1,500,000.00) and in the form of a Letter of Credit within five (5) Business Days following the Execution Date of this Agreement until Seller posts Project Development Security pursuant to Section 8.4(a)(ii) below with Buyer;

(ii) Project Development Security pursuant to this Section 8.4(a)(ii) in the amount of five million five hundred thousand dollars (\$5,500,000.00) and in the form of a Letter of Credit from a date not later than thirty (30) days following the date on which all of the Conditions Precedent set forth in Section 2.5 are either satisfied or waived until Seller posts Delivery Term Security pursuant to Section 8.4(a)(iii) below with Buyer; provided that if Buyer collects or is entitled to collect Daily Delay Damages from Seller during the Construction Cure Period for failure to achieve the Guaranteed Construction Start Date (after giving effect to Permitted Extensions), Seller agrees that within ten (10) Business Days following the end of the Construction Cure Period it shall replenish the Project Development Security by an amount equal to the encumbered Project Development Security; provided further that, with Buyer's consent, Seller may elect to apply the Project Development Security posted pursuant to Section 8.4(a)(i) toward the Project Development Security posted pursuant to this Section 8.4(a)(ii); and

(iii) Delivery Term Security pursuant to this Section 8.4(a)(iii) in the amount of nineteen million four hundred seventy-eight thousand seven hundred and twenty-one dollars (\$19,478,721.00) and in the form of a Letter of Credit or Guaranty from the Commercial Operation Date until the end of the Term; provided that, with Buyer's consent, Seller may elect to apply the Project Development Security posted pursuant to Section 8.4(a)(ii) toward the Delivery Term Security posted pursuant to this Section 8.4(a)(iii). Notwithstanding the foregoing, if Buyer has received a Capacity Reduction Notice in accordance with Section 3.9(c)(iv)(C) and Seller has paid the liquidated damages required pursuant to that section, then this Agreement, including this

Section 8.4(a)(iii), Seller may reduce the Delivery Term Security amount on a pro rata basis to reflect the reduced Contract Capacity set forth in the Capacity Reduction Notice.

Except as provided in Section 5.8, the amount of Performance Assurance required under this Agreement shall not be deemed a limitation of damages.

(b) Use of Project Development Security. Buyer shall be entitled to draw upon the Project Development Security posted by Seller for Daily Delay Damages until such time as the Project Development Security is exhausted. Buyer shall also be entitled to draw upon the Project Development Security for any damages arising upon Buyer's declaration of an Early Termination Date or a reduction in Contract Capacity by Seller in accordance with Section 3.9(c)(iv)(C).

(c) Termination of Project Development Security. If after the Commercial Operation Date no damages are due and owing to Buyer under this Agreement, then Seller shall no longer be required to maintain the Project Development Security, and Buyer shall return to Seller the Project Development Security, less the amounts drawn in accordance with Section 8.4(b). If Seller has met the Guaranteed Commercial Operation Date, then the Project Development Security returned shall include amounts held by Buyer as Daily Delay Damages due to a delayed Construction Start Date. The Project Development Security (or portion thereof) due to Seller shall be returned to Seller within five (5) Business Days of Seller's provision of the Delivery Term Security unless, with Buyer's consent, Seller elects to apply the Project Development Security posted pursuant to Section 8.4(a)(ii) toward the Delivery Term Security posted pursuant to Section 8.4(a)(iii).

(d) Payment and Transfer of Interest. Buyer shall pay interest on cash held as Project Development Security or Delivery Term Security, as applicable, at the Interest Rate and on the Interest Payment Date. All accrued interest on the unused Project Development Security or Delivery Term Security, if applicable, shall be transferred to Seller in the form of cash by wire transfer to the bank account specified under "Wire Transfer" in Appendix XI, (Notices List).

(e) Return of Delivery Term Security. Buyer shall return the unused portion of Delivery Term Security, including the payment of any interest due thereon, pursuant to Section 8.4(d) above, to Seller promptly after the following has occurred: (i) the Term of the Agreement has ended, or subject to Section 8.3, an Early Termination Date has occurred, as applicable; and (ii) all payment obligations of the Seller arising under this Agreement, including but not limited to payments pursuant to Section 4.5 (CAISO Charges), Termination Payment, indemnification payments or other damages are paid in full (whether directly or indirectly such as through set-off or netting).

8.5 Letter of Credit.

(a) If Seller has provided a Letter of Credit pursuant to any of the applicable provisions in this Article Eight, then Seller shall renew or cause the renewal of each outstanding Letter of Credit on a timely basis as provided in the relevant Letter of Credit and in accordance with this Agreement. In the event the issuer of such Letter of Credit (i) fails to maintain a Credit Rating of at least an A2 by Moody's and at least an A by S&P, (ii) indicates its intent not to renew such Letter of Credit, or (iii) fails to honor Buyer's properly documented request to draw on an outstanding Letter of Credit by such issuer, Seller shall cure such default by complying with either (A) or (B) below in an amount equal to the outstanding Letter of Credit, and by

completing the action within five (5) Business Days after Buyer receives Notice of such refusal (all of which is considered the “Cure”):

(A) providing a substitute Letter of Credit that is issued by a qualified bank acceptable to Buyer, other than the bank failing to honor the outstanding Letter of Credit, or

(B) posting cash.

If Seller fails to Cure or if such Letter of Credit expires or terminates without a full draw thereon by Buyer, or fails or ceases to be in full force and effect at any time that such Letter of Credit is required pursuant to the terms of this Agreement, then Seller shall have failed to meet the creditworthiness/collateral requirements of Article Eight.

(b) In all cases, the reasonable costs and expenses of establishing, renewing, substituting, canceling, increasing, reducing, or otherwise administering the Letter of Credit shall be borne by Seller.

ARTICLE NINE: GOVERNMENTAL CHARGES

9.1 Cooperation. Each Party shall use reasonable efforts to implement the provisions of and to administer this Agreement in accordance with the intent of the Parties to minimize all taxes, so long as neither Party is materially adversely affected by such efforts.

9.2 Governmental Charges. Seller shall pay or cause to be paid all taxes imposed by any Governmental Authority (“Governmental Charges”) on or with respect to the Product or the Transaction arising at the Delivery Point, including, but not limited to, ad valorem taxes and other taxes attributable to the Project, land, land rights or interests in land for the Project. Buyer shall pay or cause to be paid all Governmental Charges on or with respect to the Product or the Transaction from the Delivery Point. In the event Seller is required by Law or regulation to remit or pay Governmental Charges which are Buyer’s responsibility hereunder, Buyer shall promptly reimburse Seller for such Governmental Charges. If Buyer is required by Law or regulation to remit or pay Governmental Charges which are Seller’s responsibility hereunder, Buyer may deduct such amounts from payments to Seller with respect to payments under the Agreement; if Buyer elects not to deduct such amounts from Seller’s payments, Seller shall promptly reimburse Buyer for such amounts upon request. Nothing shall obligate or cause a Party to pay or be liable to pay any Governmental Charges for which it is exempt under the Law. A Party that is exempt at any time and for any reason from one or more Governmental Charges bears the risk that such exemption shall be lost or the benefit of such exemption reduced; and thus, in the event a Party’s exemption is lost or reduced, each Party’s responsibility with respect to such Governmental Charge shall be in accordance with the first four sentences of this Section.

ARTICLE TEN: MISCELLANEOUS

10.1 Recording. Unless a Party expressly objects to a recording at the beginning of a telephone conversation, each Party consents to the creation of a tape or electronic recording of all telephone conversations between Buyer’s employees or representatives performing a Scheduling Coordinator function as provided in Section 3.4(c) and any representative of Seller. The Parties agree that any such recordings will be retained in confidence, secured from improper access, and may be submitted in evidence in any proceeding or action relating to this Agreement. Each Party waives any further notice of such monitoring or recording, and agrees to notify its officers and

employees of such monitoring or recording and to obtain any necessary consent of such officers and employees.

10.2 Representations and Warranties.

(a) General Representations and Warranties. On the Execution Date, each Party represents and warrants to the other Party that:

(i) it is duly organized, validly existing and in good standing under the Laws of the jurisdiction of its formation;

(ii) it has all regulatory authorizations necessary for it to perform its obligations under this Agreement, except for (A) CPUC Approval in the case of Buyer, and (B) all permits necessary to install, operate and maintain the Project in the case of Seller;

(iii) the execution, delivery and performance of this Agreement is within its powers, have been duly authorized by all necessary action and do not violate any of the terms and conditions in its governing documents, any contracts to which it is a party or any Laws applicable to it;

(iv) this Agreement and each other document executed and delivered in accordance with this Agreement constitutes a legally valid and binding obligation enforceable against it in accordance with its terms, subject to any Equitable Defenses;

(v) it is not Bankrupt and there are no proceedings pending or being contemplated by it or, to its knowledge, threatened against it which would result in it being or becoming Bankrupt;

(vi) there is not pending or, to its knowledge, threatened against it or any of its Affiliates, any legal proceedings that could materially adversely affect its ability to perform its obligations under this Agreement;

(vii) no Event of Default with respect to it has occurred and is continuing and no such event or circumstance would occur as a result of its entering into or performing its obligations under this Agreement;

(viii) it is acting for its own account, has made its own independent decision to enter into this Agreement and as to whether this Agreement is appropriate or proper for it based upon its own judgment, is not relying upon the advice or recommendations of the other Party in so doing, and is capable of assessing the merits of and understanding, and understands and accepts, the terms, conditions and risks of this Agreement; and

(ix) it has entered into this Agreement in connection with the conduct of its business and it has the capacity or the ability to make or take delivery of the Product as provided in this Agreement.

(b) Seller Representations and Warranties. Seller, and, if applicable, its successors, represents and warrants that throughout the Delivery Term of this Agreement that: (i) the Project qualifies and is certified by the CEC as an Eligible Renewable Energy Resource (“ERR”) as such term is defined in Public Utilities Code Section 399.12 or Section 399.16; and (ii) the Project’s output delivered to Buyer qualifies under the requirements of the California

Renewables Portfolio Standard. To the extent a change in law occurs after execution of this Agreement that causes this representation and warranty to be materially false or misleading, it shall not be an Event of Default if Seller has used commercially reasonable efforts to comply with such change in law.

Seller and, if applicable, its successors, represents and warrants that throughout the Delivery Term of this Agreement the Renewable Energy Credits transferred to Buyer conform to the definition and attributes required for compliance with the California Renewables Portfolio Standard, as set forth in California Public Utilities Commission Decision 08-08-028, and as may be modified by subsequent decision of the California Public Utilities Commission or by subsequent legislation. To the extent a change in law occurs after execution of this Agreement that causes this representation and warranty to be materially false or misleading, it shall not be an Event of Default if Seller has used commercially reasonable efforts to comply with such change in law.

(c) Supplement to Seller Representations and Warranties. To the extent a change in Law occurs after execution of this Agreement that causes the representation and warranty set forth in Section 10.2(b) above to be materially false or misleading, Seller shall be deemed to have made commercially reasonable efforts to comply with such change in Law if Seller takes all actions to comply with or implement any change or improvement to the Project to maintain such certification or qualification (“RPS Qualification Improvement”) which would require Seller to incur, in the aggregate, costs up to one million dollars (\$1,000,000.00) over the Term of this Agreement (“RPS Qualification Expenditure Maximum”). If after such change in Law has occurred, Seller determines that it will exceed the RPS Qualification Expenditure Maximum to implement the RPS Qualification Improvement, Seller shall notify Buyer and provide documentation and calculations to support the expected exceedence (“RPS Qualification Improvement Notice”). Buyer shall then have sixty (60) days after receipt of the RPS Qualification Improvement Notice to verify or dispute Seller’s documentation and calculation. The Parties shall then have thirty (30) days to agree in writing (such agreement not to be unreasonably withheld, conditioned or delayed) on the amount by which Seller will exceed the RPS Qualification Expenditure Maximum in order to satisfy the RPS Qualification Improvement (“RPS Qualification Improvement Amount Agreement”). Buyer may then:

(i) elect to pay Seller the amount set forth in the RPS Qualification Improvement Amount Agreement and notify Seller of such election, subject to CPUC Approval (if required), within ten (10) Business Days of the effective date of the RPS Qualification Improvement Amount Agreement. If Buyer so elects, Seller shall, upon receipt of payment from Buyer, implement the RPS Qualification Improvement; or

(ii) elect not to pay Seller for the amount set forth in the RPS Qualification Improvement Amount Agreement and notify Seller of such decision within ten (10) Business Days of the effective date of the RPS Qualification Improvement Amount Agreement, in which case this Agreement shall continue in full force and effect and Seller shall not be required to implement any further or additional RPS Qualification Improvement.

10.3 Covenants.

(a) General Covenants. Each Party covenants that throughout the Delivery Term:

(i) it shall continue to be duly organized, validly existing and in good standing under the Laws of the jurisdiction of its formation;

(ii) it shall maintain (or obtain from time to time as required, including through renewal, as applicable) all regulatory authorizations necessary for it to legally perform its obligations under this Agreement and the Transaction; and

(iii) it shall perform its obligations under this Agreement and the Transaction in a manner that does not violate any of the terms and conditions in its governing documents, any contracts to which it is a party or any Law, rule, regulation, order or the like applicable to it.

(b) Seller Covenants.

(i) Seller covenants throughout the Delivery Term that it will take no action or permit any other person or entity (other than Buyer) to take any action that would impair in any way Buyer's ability to rely on the Project in order to satisfy its Resource Adequacy Requirements; and

(ii) Seller covenants that it shall comply with all CAISO Tariff requirements applicable to an Interconnection Customer (as defined in the CAISO Tariff) and shall take any other necessary action, including but not limited to payment of fees and submission of requests, applications or other documentation, to promote the completion of the Electric System Upgrades prior to the Commercial Operation date or as soon as practicable thereafter.

10.4 Title and Risk of Loss. Title to and risk of loss related to the Product shall transfer from Seller to Buyer at the Delivery Point. Seller warrants that it will deliver to Buyer the Product free and clear of all liens, security interests, Claims and encumbrances or any interest therein or thereto by any person or entity arising prior to or at the Delivery Point.

10.5 Indemnities.

(a) Indemnity by Seller. Seller shall release, indemnify and hold harmless Buyer or Buyers' respective directors, officers, agents, and representatives against and from any and all loss, Claims, actions or suits, including costs and attorney's fees resulting from, or arising out of or in any way connected with (i) the Product delivered under this Agreement to the Delivery Point, (ii) Seller's operation and/or maintenance of the Project, or (iii) Seller's actions or inactions with respect to this Agreement, including, without limitation, any loss, Claim, action or suit, for or on account of injury to, bodily or otherwise, or death of persons, or for damage to or destruction of property belonging to Buyer, Seller, or others, excepting only such loss, Claim, action or suit as may be caused solely by the willful misconduct or gross negligence of Buyer, its Affiliates, or Buyers' and Affiliates' respective agents, employees, directors, or officers.

(b) Indemnity by Buyer. Buyer shall release, indemnify and hold harmless Seller, its directors, officers, agents, and representatives against and from any and all loss, Claims, actions or suits, including costs and attorney's fees resulting from, or arising out of or in

any way connected with the Product delivered by Seller under this Agreement after the Delivery Point, including, without limitation, any loss, Claim, action or suit, for or on account of injury to, bodily or otherwise, or death of persons, or for damage to or destruction of property belonging to Buyer, Seller, or others, excepting only such loss, Claim, action or suit as may be caused solely by the willful misconduct or gross negligence of Seller, its Affiliates, or Seller's and Affiliates' respective agents, employees, directors or officers.

(c) No Dedication. Without limitation of each Party's obligations under Sections 10.5(a) and 10.5(b) herein, nothing in this Agreement shall be construed to create any duty to, any standard of care with reference to, or any liability to any person or entity not a Party to this Agreement. No undertaking by one Party to the other under any provision of this Agreement shall constitute the dedication of that Party's system or any portion thereof to the other Party or the public, nor affect the status of Buyer as an independent public utility corporation or Seller as an independent individual or entity.

10.6 Assignment.

(a) General Assignment. Except as provided in Sections 10.6 (b) and (c), neither Party shall assign this Agreement or its rights hereunder without the prior written consent of the other Party, which consent shall not be unreasonably withheld so long as among other things (i) the assignee assumes the transferring Party's payment and performance obligations under this Agreement, (ii) the assignee agrees in writing to be bound by the terms and conditions hereof, (iii) the transferring Party delivers evidence satisfactory to the non-transferring Party of the proposed assignee's technical and financial capability to fulfill the assigning Party's obligations hereunder and (iv) the transferring Party delivers such tax and enforceability assurance as the other Party may reasonably request. Notwithstanding the foregoing and except as provided in Section 10.6(b), consent shall not be required for an assignment of this Agreement where the assigning Party remains subject to liability or obligation under this Agreement, provided that (i) the assignee assumes the assigning Party's payment and performance obligations under this Agreement, (ii) the assignee agrees in writing to be bound by the terms and conditions hereof, and (iii) the assigning Party provides the other Party hereto with at least thirty (30) days' prior written notice of the assignment.

(b) Assignment to Financing Providers. Seller shall be permitted to assign this Agreement as collateral for any financing or refinancing of the Project with the prior written consent of the Buyer, which consent shall not be unreasonably withheld. If Buyer gives its consent, then such consent shall be in a form substantially similar to the Form of Consent to Assignment attached hereto as Appendix XII provided that (i) Buyer shall not be required to consent to any additional terms or conditions beyond those contained in Appendix XII, including but not limited to extension of any cure periods or additional remedies for financing providers, and (ii) Seller shall be responsible at Buyer's request for Buyer's reasonable costs associated with the review, negotiation, execution and delivery of documents in connection with such assignment, including without limitation attorneys' fees.

(c) Assignment in Connection with a Change in Control. Any direct or indirect change of control of Seller (whether voluntary or by operation of Law) shall be deemed an assignment and shall require the prior written consent of Buyer, which consent shall not be unreasonably withheld.

(d) Unauthorized Assignment. Any assignment or purported assignment in violation of this Section 10.6 is void.

10.7 Confidentiality.

Confidentiality Notification: If checked, Seller has waived its right to notification in accordance with Section 10.7(b).

(a) Neither Party shall disclose the non-public terms or conditions of this Agreement to a third party, other than as follows:

(i) to the Party's Affiliates, the Party's or its Affiliates' respective employees, lenders, investors, counsel, accountants or advisors who have a need to know such information and have agreed to keep such terms confidential,

(ii) for disclosure to Buyer's Procurement Review Group, as defined in CPUC Decision D. 02-08-071, subject to a confidentiality agreement,

(iii) to the CPUC under seal for purposes of review,

(iv) for disclosure of those certain terms specified in and pursuant to Section 10.8 of this Agreement;

(v) in order to comply with any applicable Law, regulation, or any exchange, control area or CAISO rule, or order issued by a court or entity with competent jurisdiction over the disclosing Party ("Disclosing Party"), other than to those entities set forth in subsection (vi); or

(vi) in order to comply with *any* applicable regulation, rule, or order of the CPUC, CEC, or the FERC.

(b) If a Party is required to disclose confidential information in order to satisfy an obligation pursuant to subsection (a)(v) above ("Disclosure Order") each Party shall, to the extent practicable, use reasonable efforts: (i) to notify the other Party prior to disclosing the confidential information and (ii) prevent or limit such disclosure. After using such reasonable efforts, the Disclosing Party shall not be: (y) prohibited from complying with a Disclosure Order or (z) liable to the other Party for monetary or other damages incurred in connection with the disclosure of the confidential information. Except as provided in the preceding sentence, the Parties shall be entitled to all remedies available at Law or in equity to enforce, or seek relief in connection with, this confidentiality obligation.

(c) Notwithstanding the provisions in Section 10.7(a), the Parties are permitted to disclose information related to the bidding and negotiation process as follows: (i) to PG&E's Procurement Review Group, as defined in California Public Utilities Commission ("CPUC") Decision (D) 02-08-071, subject to a confidentiality agreement, (ii) to the CPUC (including CPUC staff) under seal for purposes of review (if such seal is applicable to the nature of the Confidential Information), and (iii) to the Independent Evaluator, as defined and specified in the PG&E RPS Solicitation Protocol issued May 11, 2011.

(d) The Parties agree that the confidentiality provisions under this Section 10.7 are separate from, and shall not impair or modify any other confidentiality agreements that may be in place between the Parties or their Affiliates; provided however, that the confidentiality provisions of this Section 10.7 shall govern confidential treatment of all information exchanged between the Parties as of and after the Effective Date.

10.8 RPS Confidentiality.

(a) Notwithstanding Section 10.7(a) of this Agreement, at any time on or after the date on which the Buyer makes its advice filing letter seeking CPUC Approval of this Agreement, either Party shall be permitted to disclose those terms required by the CPUC in its then-current advice letter template, including the following: Party names, resource type, Delivery Term, Project location, capacity factor, Contract Capacity, anticipated Commercial Operation Date, Contract Quantity, Delivery Point, applicability of the Energy Investment Tax Credit or Production Tax Credit.

(b) Seller acknowledges and agrees that pursuant to CPUC Decision D.06-06-066, which implements Senate Bill (SB) No. 1488 (2004 Cal. Stats., Ch. 690 (Sept. 22, 2004)), this Agreement may be publicly available three (3) years from the Commercial Operation Date stated herein. Seller further acknowledges that the CPUC's rules regarding confidential treatment of this Agreement is subject to change and therefore the timing and extent of disclosure is subject to amendment per CPUC order, rule or regulation.

10.9 Audit. Each Party has the right, at its sole expense and during normal working hours, after reasonable Notice, to examine the records of the other Party to the extent reasonably necessary to verify the accuracy of any statement, charge or computation made pursuant to this Agreement including amounts of Delivered Energy. If any such examination reveals any inaccuracy in any statement, the necessary adjustments in such statement and the payments thereof will be made promptly and shall bear interest calculated at the Interest Rate from the date the overpayment or underpayment was made until paid; provided, however, that no adjustment for any statement or payment will be made unless objection to the accuracy thereof was made prior to the lapse of twelve (12) months from the rendition thereof, and thereafter any objection shall be deemed waived.

10.10 Insurance. Throughout the Term, Seller shall, at its sole cost and expense, obtain and maintain the following insurance coverages and be responsible for its subcontractors, including Seller's EPC Contractors, maintaining sufficient limits of the appropriate insurance coverage.

(a) Workers' Compensation and Employers' Liability.

(i) If applicable, Workers' Compensation insurance indicating compliance with any applicable labor codes, acts, Laws or statutes, state or federal, where Seller performs Work.

(ii) Employers' Liability insurance shall not be less than one million dollars (\$1,000,000.00) for injury or death occurring as a result of each accident.

(b) Commercial General Liability.

(i) Coverage shall be at least as broad as the Insurance Services Office Commercial General Liability Coverage "occurrence" form, with no alterations to the coverage form.

(ii) The limit shall not be less than ten million dollars (\$10,000,000.00) each occurrence for bodily injury, property damage, personal injury and products/completed operations. Defense costs shall be provided as an additional benefit and not

included within the limits of liability. Coverage limits may be satisfied using an umbrella or excess liability policy or an Owners Contractors Protective (OPC) policy. Limits shall be on a per project basis.

(iii) If scope of Work involves hauling hazardous materials, coverage shall be endorsed in accordance with Section 30 of the Motor Carrier Act of 1980 (Category 2) and the CA 99 48 endorsement.

(iv) Coverage shall:

(A) by “Additional Insured” endorsement add as insureds PG&E, its directors, officers, agents and employees with respect to liability arising out of the Work performed by or for the Seller (Insurance Services Office Form CG2010 1185, or equivalent form). In the event the Commercial General Liability policy includes a “blanket endorsement by contract,” the following language added to the certificate of insurance will satisfy Buyer’s requirement: “PG&E, its directors, officers, agents and employees with respect to liability arising out of the Work performed by or for the Seller has been endorsed by blanket endorsement;”

(B) be endorsed to specify that the Seller's insurance is primary and that any insurance or self-insurance maintained by PG&E shall not contribute with it; and

(C) include a severability of interest clause.

(c) Business Auto.

(i) If applicable, Business Auto coverage shall be at least as broad as the Insurance Services Office Business Auto Coverage form covering Automobile Liability, code 1 “any auto”.

(ii) The limit shall not be less than five million dollars (\$5,000,000.00) each accident for bodily injury and property damage.

(iii) If scope of Work involves hauling hazardous materials, coverage shall be endorsed in accordance with Section 30 of the Motor Carrier Act of 1980 (Category 2) and the CA 99 48 endorsement.

(d) Aircraft Liability.

(i) If the scope of Work involves aircraft, coverage for bodily injury, property damage, including injury sustained by any passenger, applying to all aircraft owned, furnished or used by the Seller in the performance of this Agreement shall be maintained. Work that involves chemical spraying shall include coverage for pesticide and herbicide application.

(ii) The limit shall not be less than five million dollars (\$5,000,000.00) single limit for bodily injury and property damage including passenger liability.

(iii) Coverage shall:

(A) by “Additional Insured” endorsement add as insureds PG&E, its directors, officers, agents and employees with respect to liability arising out of Work performed by or for the Seller;

(B) be endorsed to specify that the Seller's insurance is primary and that any insurance or self-insurance maintained by PG&E shall not contribute with it; and

(C) all rights of subrogation against PG&E shall be waived with respect to all physical damage to any aircraft used during the performance of this Agreement.

(e) Watercraft Liability.

(i) If the scope of Work involves watercraft, Marine protection and indemnity or other liability coverage, including coverage for injury sustained by any passenger, apply to all watercraft used in the performance of this Agreement.

(ii) The limit shall not be less than one million dollars (\$1,000,000.00) for each occurrence for bodily injury and property damage including passenger legal liability.

(iii) Coverage shall:

(A) by “Additional Insured” endorsement add as insureds PG&E, its directors, officers, agents and employees with respect to liability arising out of the Work by or for the Seller;

(B) be endorsed to specify that the Seller's insurance is primary and that any insurance or self-insurance maintained by PG&E shall not contribute with it.

(f) Seller’s Pollution Liability.

(i) If the scope of Work involves areas of known pollutants or contaminants, pollution liability coverage shall be required to cover bodily injury, property damage, including clean up costs and defense costs resulting from sudden, and accidental conditions, including the discharge, dispersal, release or escape of smoke, vapors, soot, fumes, acids, alkalis, toxic chemicals, hydrocarbons, liquids or gases, waste materials or other irritants, contaminants or pollutants into or upon land, the atmosphere or any water course or body of water shall be maintained.

(ii) The limit shall not be less than one million dollars (\$1,000,000.00) each occurrence for bodily injury and property damage.

(iii) The policy shall endorse PG&E as additional insured.

(g) All Risk Property Insurance. An all risk property insurance policy including earthquake and flood shall be maintained during the course of Work being performed and include start-up and testing for installed equipment and delayed opening coverage. Such

policy shall include coverage for materials and equipment while under the care, custody and control of the Seller during the course of Work, at the Site, offsite or while in transit to the Site.

(h) Professional Liability Insurance.

(i) If the scope of Work involves professional reports or reviews such as architects or engineer's stamped drawings, then maintain or cause to be maintained errors and omissions liability insurance appropriate to the architect's or engineer's profession shall be required. Coverage shall be for a professional error, act or omission arising out of the scope of services provided to Seller in connection with the design, development, or use of the Project, including coverage for bodily injury, property damage, and consequential financial loss.

(ii) The limit shall not be less than ten million dollars (\$10,000,000.00) per claim.

(iii) Coverage shall:

(A) be endorsed to specify that the Seller's insurance is primary and that any Insurance or self-insurance maintained by PG&E shall not contribute with it; and

(B) be endorsed to specify that the selection of counsel, paid for by the insurer, to defend PG&E and its officers, directors, agents, and employees against covered or potentially covered claims shall be by mutual consent of PG&E and insurer.

(i) Additional Insurance Requirements.

(i) Before commencing performance of the Work, Seller shall furnish PG&E with certificates of insurance and endorsements of all required insurance for Seller.

(ii) The documentation shall state that coverage shall not be cancelled except after thirty (30) days prior written Notice has been given to PG&E.

(iii) Buyer uses a third party vendor, Exigis, to confirm and collect insurance documents. Certificates of insurance and endorsements shall be signed and submitted by a person authorized by the insurer to bind coverage on Seller's behalf, and submitted through the Exigis website at <https://prod1.exigis.com/pge>, or such other method, as directed by Buyer. The Exigis helpline is 1 (888) 280-0178. The certificate holder shall be listed as "Pacific Gas and Electric Company c/o Exigis." Seller's insurance vendor and broker will be required to register as a "Service Provider" on the Exigis website.

(iv) Reviews of such insurance may be conducted by PG&E on an annual basis and, in addition, PG&E may inspect the original policies at any time.

(v) Upon request, Seller shall furnish Buyer evidence of insurance for its subcontractors.

(vi) The insurance carrier or carriers and form of policy shall be subject to review and approval by PG&E.

(j) Form And Content.

(i) All policies or binders with respect to insurance maintained by Seller shall:

(A) waive any right of subrogation of the insurers hereunder against PG&E, its officers, directors, employees, agents and representatives of each of them, and any right of the insurers to any setoff or counterclaim or any other deduction, whether by attachment or otherwise, in respect of any liability of any such person insured under such policy; and

(B) with respect to any additional insured, provide that such insurance will not be invalidated by any action or inaction of each such insured and will insure each such insured regardless of any breach or violation of any warranty, declaration or condition contained in such insurance by the primary named insured.

10.11 Access to Financial Information. The Parties agree that Generally Accepted Accounting Principles and SEC rules require Buyer to evaluate if Buyer must consolidate Seller's financial information. Buyer will require access to financial records and personnel to determine if consolidated financial reporting is required. If Buyer determines that consolidation is required, Buyer shall require the following during every calendar quarter for the Term:

(a) Complete financial statements and notes to financial statements; and

(b) Financial schedules underlying the financial statements, all within fifteen (15) days after the end of each fiscal quarter.

Any information provided to Buyer pursuant to this Section 10.11 shall be considered confidential in accordance with the terms of this Agreement and shall only be disclosed on an aggregate basis with other similar entities for which Buyer has power purchase agreements. The information will only be used for financial statement purposes and shall not be otherwise shared with internal or external parties.

10.12 Governing Law. This agreement and the rights and duties of the parties hereunder shall be governed by and construed, enforced and performed in accordance with the laws of the state of California, without regard to principles of conflicts of law. To the extent enforceable at such time, each party waives its respective right to any jury trial with respect to any litigation arising under or in connection with this agreement.

10.13 General. This Agreement shall be considered for all purposes as prepared through the joint efforts of the Parties and shall not be construed against one Party or the other as a result of the preparation, substitution, submission or other event of negotiation, drafting or execution hereof. Except to the extent provided for, no amendment or modification to this Agreement shall be enforceable unless reduced to writing and executed by both Parties. This Agreement shall not impart any rights enforceable by any third party (other than a permitted successor or assignee bound to this Agreement). Waiver by a Party of any default by the other Party shall not be construed as a waiver of any other default. The headings used herein are for convenience and reference purposes only. Facsimile or PDF transmission will be the same as delivery of an original document; provided that at the request of either Party, the other Party will confirm facsimile or PDF signatures by signing and delivering an original document; provided, however, that the execution and delivery of this Agreement and its counterparts shall be subject to

Section 10.15. This Agreement shall be binding on each Party's successors and permitted assigns. The standard of review the FERC shall apply when acting on proposed modifications to this Agreement, either on FERC's own motion or on behalf of a signatory or a non-signatory, shall be the "just and reasonable" standard of review rather than the "public interest" standard of review. Nothing in this Agreement shall in any way restrict or otherwise limit the rights of either Party under Sections 205 and 206 of the Federal Power Act.

10.14 Severability. If any provision in this Agreement is determined to be invalid, void or unenforceable by any court having jurisdiction, such determination shall not invalidate, void, or make unenforceable any other provision, agreement or covenant of this Agreement and the Parties shall use their best efforts to modify this Agreement to give effect to the original intention of the Parties.

10.15 Counterparts. This Agreement may be executed in one or more counterparts each of which shall be deemed an original and all of which shall be deemed one and the same Agreement. Delivery of an executed counterpart of this Agreement by fax will be deemed as effective as delivery of an originally executed counterpart. Any Party delivering an executed counterpart of this Agreement by facsimile will also deliver an originally executed counterpart, but the failure of any Party to deliver an originally executed counterpart of this Agreement will not affect the validity or effectiveness of this Agreement.

10.16 Discussions Concerning Buyer Purchase of Project. Upon Notice to the other Party, either Party may initiate good faith negotiations regarding a potential purchase at fair market value by the Buyer of the Project and all assets and rights held by the Seller or any Affiliate of the Seller that relate to the Project and/or its construction, ownership, operation or maintenance, including without limitations real property, physical plant, tangible personal property, permits, agreements, consents, books and records, intellectual property and data. Such negotiations shall also include representations and warranties, indemnities, closing conditions and covenants which are customary and usual in agreements providing for the acquisition of similar assets. The Buyer's acquisition shall be conditioned on the final and non-appealable prior approval by the California Public Utilities Commission of such ratemaking and other conditions as the Buyer may request in an appropriate filing requesting such approval.

ARTICLE ELEVEN: TERMINATION EVENTS

11.1 Intentionally omitted.

11.2 Force Majeure Termination Event.

(a) Force Majeure Failure. Buyer shall have the right, but not the obligation, to terminate this Agreement after the occurrence of the following:

(i) if after the Commercial Operation Date,:

(A) the Project fails to deliver at least forty percent (40%) of the Contract Quantity to the Delivery Point for a period of twelve (12) consecutive rolling months following a Force Majeure event that materially and adversely impacts the Project ("Force Majeure Project Failure") and Buyer has notified Seller of such failure; provided that if Seller within forty-five (45) days of receipt of Notice from Buyer regarding the Force Majeure Project Failure, presents Buyer with a plan for mitigation of the effect of the Force Majeure within a period not to exceed six (6) months from above-mentioned Notice date, which plan is

commercially reasonable and satisfactory to Buyer, as evidenced by Buyer's written acknowledgement of such plan, then Buyer shall not have the right to terminate this Agreement pursuant to this Section 11.2(a) until the expiration of the additional period deemed necessary by Seller to repair the Project (not to exceed six (6) months); provided that Seller diligently pursues such mitigation plan throughout said additional period, and after which time Buyer may terminate unless the Project has been repaired, and the Seller has resumed and is satisfying its performance obligations under this Agreement; or

(B) the Project is destroyed or rendered inoperable by a Force Majeure caused by a catastrophic natural disaster; provided that Seller shall have up to ninety (90) days following such Force Majeure event to obtain a report from an independent, third party engineer stating whether the Project is capable of being repaired or replaced within twenty-four (24) additional months or less from the date of the report and provide Buyer a copy of the engineer's report, at no cost to Buyer; provided further that if such engineer's report concludes that the Project is capable of being repaired or replaced within such twenty-four (24) month period and Seller undertakes and continues such repair or replacement with due diligence, then Buyer shall not have the right to terminate this Agreement pursuant to this Section 11.2(a) until the expiration of the period deemed necessary by the engineer's report (not to exceed twenty-four (24) months), after which time, Buyer may terminate unless the Project has been repaired or replaced, as applicable, and the Seller has resumed and is satisfying its performance obligations under this Agreement;

(ii) if prior to the Construction Start Date or Commercial Operation Date, as applicable, Seller is unable, due solely to a Force Majeure event, to achieve the Construction Start Date or place the Project into Commercial Operation by either of the Guaranteed Milestones, after applicable extensions or cure periods have run, as set forth in Sections 3.9(c)(iii) and (iv) (in either case a "Force Majeure Development Failure"); provided that in the event of a Force Majeure caused by a catastrophic natural disaster, upon Buyer's written request to Seller, Seller shall have not more than ninety (90) days from the date of such Force Majeure event to obtain a report from an independent, third party engineer stating whether the Project is capable of being repaired or replaced within twenty-four (24) additional months and provide Buyer a copy of the engineer's report, at no cost to Buyer provided further that if such engineer's report concludes that the Project is capable of being repaired or replaced within such twenty-four (24) month period and Seller undertakes and continues such repair or replacement with due diligence, then Buyer shall not have the right to terminate this Agreement pursuant to this Section 11.2(a) until the expiration of the period deemed necessary by the engineer's report (not to exceed twenty-four (24) months), after which time, Buyer may terminate unless the Project has been repaired or replaced, as applicable, and the Seller has resumed and is satisfying its performance obligations under this Agreement.

(b) Right of First Offer.

(i) If Buyer exercises its termination right in connection with the Force Majeure Failure, then for a period of three (3) years from the date on which Buyer Notifies Seller of such termination ("Exclusivity Period"), neither Seller, its successors and assigns, nor its Affiliates shall enter into an obligation or agreement to sell or otherwise transfer any Products from the Project to any third party, unless Seller first offers, in writing, to sell to Buyer such Products from the Project on the same terms and conditions as this Agreement, subject to permitted modifications identified in subpart (ii) below, (the "First Offer") and Buyer either accepts or rejects such First Offer in accordance with the provisions herein.

(ii) If Buyer accepts the First Offer, Buyer shall Notify Seller within thirty (30) days of receipt of the First Offer subject to Buyer's management approval and CPUC Approval ("Buyer's Notice"), and then the Parties shall have not more than ninety (90) days from the date of Buyer's Notice to enter into a new power purchase agreement, in substantially the same form as this Agreement, or amend this Agreement, subject to CPUC Approval, if necessary; provided that the Contract Price may only be increased to reflect Seller's documented incremental costs in overcoming the Force Majeure event.

(iii) If Buyer rejects or fails to accept Seller's First Offer within thirty (30) days of receipt of such offer, Seller shall thereafter be free to sell or otherwise transfer, and to enter into agreements to sell or otherwise transfer, any Products from the Project to any third party, so long as the material terms and conditions of such sale or transfer are not more favorable to the third party than those of the First Offer to Buyer. If, during the Exclusivity Period, Seller desires to enter into an obligation or agreement with a third party, Seller shall deliver to Buyer a certificate of an authorized officer of Seller (A) summarizing the material terms and conditions of such agreement and (B) certifying that the proposed agreement with the third party will not provide Seller with a lower rate of return than that offered in the First Offer to Buyer. Seller's certificate shall be in substantially the form of Appendix IX. If Seller is unable to deliver such a certificate to Buyer, then Seller may not sell or otherwise transfer, or enter into an agreement to sell or otherwise transfer, the Products from the Project without first offering to sell or otherwise transfer such Products to Buyer on such more favorable terms and conditions (the "Revised Offer") in accordance with subpart (ii) above. If within thirty (30) days of receipt of Seller's Revised Offer the Buyer rejects, or fails to accept by Notice to Seller, the Revised Offer, then Seller will thereafter be free to sell or otherwise transfer, and to enter into agreements to sell or otherwise transfer, such Products from the Project to any third party on such terms and conditions as set forth in the certificate.

ARTICLE TWELVE: DISPUTE RESOLUTION

12.1 Intent of the Parties. Except as provided in the next sentence, the sole procedure to resolve any claim arising out of or relating to this Agreement is the dispute resolution procedure set forth in this Article Twelve. The lone exception to the foregoing is that either Party may seek an injunction in Superior Court in San Francisco, California if such action is necessary to prevent irreparable harm, in which case both Parties nonetheless will continue to pursue resolution of all other aspects of the dispute by means of this procedure.

12.2 Management Negotiations.

(a) The Parties will attempt in good faith to resolve any controversy or claim arising out of or relating to this Agreement by prompt negotiations between each Party's Authorized Representative, or such other person designated in writing as a representative of the Party (each a "Manager"). Either Manager may request a meeting to, be held in person or telephonically, to initiate negotiations to be held within ten (10) Business Days of the other Party's receipt of such request, at a mutually agreed time and place. If the matter is not resolved within fifteen (15) Business Days of their first meeting ("Initial Negotiation End Date"), the Managers shall refer the matter to the designated senior officers of their respective companies ("Executive(s)"), who shall have authority to settle the dispute. Within five (5) Business Days of the Initial Negotiation End Date ("Referral Date"), each Party shall provide one another written Notice confirming the referral and identifying the name and title of the Executive who will represent the Party.

(b) Within five (5) Business Days of the Referral Date, the Executives shall establish a mutually acceptable location and date to meet, which date shall not be greater than thirty (30) days from the Referral Date. After the initial meeting date, the Executives shall meet, as often as they reasonably deem necessary, to exchange relevant information and to attempt to resolve the dispute.

(c) All communication and writing exchanged between the Parties in connection with these negotiations shall be deemed confidential and subject to the confidentiality provisions of this Agreement. All such communication and writing shall be inadmissible as evidence such that it cannot be used or referred to in any subsequent binding adjudicatory process between the Parties, whether with respect to this dispute or any other.

(d) If the matter is not resolved within forty-five (45) days of the Referral Date, or if the Party receiving the written request to meet, pursuant to Section 12.2(a), refuses or does not meet within the ten (10) Business Day period specified in Section 12.2(a), either Party may initiate mediation of the controversy or claim according to the terms of the following Section 12.3.

12.3 Mediation. If the dispute cannot be resolved by negotiation as set forth in Section 12.2 above, then either Party may initiate mediation, the first-step of a two-step dispute resolution process, which JAMS shall administer. As the first step, the Parties agree to mediate any controversy before a commercial mediator from the JAMS panel, pursuant to JAMS's then-applicable commercial mediation rules, in San Francisco, California. Either Party may initiate such a mediation by serving a written demand for mediation. The mediator shall not have the authority to require, and neither Party may be compelled to engage in, any form of discovery prior to or in connection with the mediation. If within sixty (60) days after service of a written demand for mediation, or as extended by mutual agreement of the Parties, the mediation does not result in resolution of the dispute, then the Parties shall resolve such controversy through Arbitration by one retired judge or justice from the JAMS panel, which Arbitration shall take place in San Francisco, California, and which the Arbitrator shall administer by and in accordance with JAMS's Commercial Arbitration Rules ("Arbitration"). If the Parties cannot mutually agree on the Arbitrator who will adjudicate the dispute, then JAMS shall provide the Parties with an Arbitrator pursuant to its then-applicable Commercial Arbitration Rules. The period commencing from the date of the written demand for mediation until the appointment of a mediator shall be included within the sixty (60) day mediation period. Any mediator(s) and arbitrator(s) shall have no affiliation with, financial or other interest in, or prior employment with either Party and shall be knowledgeable in the field of the dispute. Either Party may initiate Arbitration by filing with the JAMS a notice of intent to arbitrate within sixty (60) days of service of the written demand for mediation.

12.4 Arbitration. At the request of a Party, the arbitrator shall have the discretion to order depositions of witnesses to the extent the arbitrator deems such discovery relevant and appropriate. Depositions shall be limited to a maximum of three (3) per Party and shall be held within thirty (30) days of the making of a request. Additional depositions may be scheduled only with the permission of the arbitrator, and for good cause shown. Each deposition shall be limited to a maximum of six (6) hours duration unless otherwise permitted by the arbitrator for good cause shown. All objections are reserved for the Arbitration hearing except for objections based on privilege and proprietary and confidential information. The arbitrator shall also have discretion to order the Parties to exchange relevant documents. The arbitrator shall also have discretion to order the Parties to answer interrogatories, upon good cause shown.

(a) Each of the Parties shall submit to the arbitrator, in accordance with a schedule set by the arbitrator, offers in the form of the award it considers the arbitrator should make. If the arbitrator requires the Parties to submit more than one such offer, the arbitrator shall designate a deadline by which time the Parties shall submit their last and best offer. In such proceedings the arbitrator shall be limited to awarding only one of the two “last and best” offers submitted, and shall not determine an alternative or compromise remedy.

(b) The arbitrator shall have no authority to award punitive or exemplary damages or any other damages other than direct and actual damages and the other remedies contemplated by this Agreement.

(c) The arbitrator’s award shall be made within nine (9) months of the filing of the notice of intention to arbitrate (demand) and the arbitrator shall agree to comply with this schedule before accepting appointment. However, this time limit may be extended by agreement of the Parties or by the arbitrator, if necessary. The California Superior Court of the City and County of San Francisco may enter judgment upon any award rendered by the arbitrator. The Parties are aware of the decision in *Advanced Micro Devices, Inc. v. Intel Corp.*, 9 Cal. 4th 362 (1994) and, except as modified by this Agreement, intend to limit the power of the arbitrator to that of a Superior Court judge enforcing California Law.

(d) The prevailing Party in this dispute resolution process is entitled to recover its costs and reasonable attorneys’ fees.

(e) The arbitrator shall have the authority to grant dispositive motions prior to the commencement of or following the completion of discovery if the arbitrator concludes that there is no material issue of fact pending before him or her.

(f) Except as may be required by Law, neither a Party nor an arbitrator may disclose the existence, content, or results of any Arbitration hereunder without the prior written consent of both Parties.

ARTICLE THIRTEEN: NOTICES

Whenever this Agreement requires or permits delivery of a “Notice” (or requires a Party to “notify”), the Party with such right or obligation shall provide a written communication in the manner specified herein; provided, however, that notices of Outages or other Scheduling or dispatch information or requests, as provided in Appendix VIII, shall be provided in accordance with the terms set forth in the relevant section of this Agreement. Notices may be sent by facsimile or e-mail. A Notice sent by facsimile transmission or e-mail will be recognized and shall be deemed received on the Business Day on which such Notice was transmitted if received before 5:00 p.m. (and if received after 5:00 p.m., on the next Business Day) and a Notice of overnight mail or courier shall be deemed to have been received two (2) Business Days after it was sent or such earlier time as is confirmed by the receiving Party. Either Party may periodically change any address, phone number, e-mail, or contact to which Notice is to be given it by providing Notice of such change to the other Party.

SIGNATURES

Agreement Execution

In WITNESS WHEREOF, each Party has caused this Agreement to be duly executed by its authorized representative as of the dates provided below:

SHILOH IV WIND PROJECT, LLC,
a Delaware limited liability company
By: enXco Development Corporation
Its: Sole Member and Manager

PACIFIC GAS AND ELECTRIC COMPANY,
a California corporation



Signature: *Paul Kaufman*
Name: Paul Kaufman
Title: EVP Transaction
Date: 7/27/11

Signature: *Fong Wan*
Name: Fong Wan
Title: Senior VP, Energy Procurement
Date: 7/20/2011

APPENDIX I

FORM OF LETTER OF CREDIT

Issuing Bank Letterhead and Address

STANDBY LETTER OF CREDIT NO. XXXXXXXX

Date: [insert issue date]

Beneficiary: Pacific Gas and Electric Company
77 Beale Street, Mail Code B28L
San Francisco, CA 94105
Attention: Credit Risk Management

Applicant: [Insert name and address of Applicant]

Letter of Credit Amount: [insert amount]

Expiry Date: [insert expiry date]

Ladies and Gentlemen:

By order of **[insert name of Applicant]** (“Applicant”), we hereby issue in favor of Pacific Gas and Electric Company (the “Beneficiary”) our irrevocable standby letter of credit No. **[insert number of letter of credit]** (“Letter of Credit”), for the account of Applicant, for drawings up to but not to exceed the aggregate sum of U.S. \$ **[insert amount in figures followed by (amount in words)]** (“Letter of Credit Amount”). This Letter of Credit is available with **[insert name of issuing bank, and the city and state in which it is located]** by sight payment, at our offices located at the address stated below, effective immediately, and it will expire at our close of business on **[insert expiry date]** (the “Expiry Date”).

Funds under this Letter of Credit are available to the Beneficiary against presentation of the following documents:

1. Beneficiary’s signed and dated sight draft in the form of Exhibit A hereto, referencing this Letter of Credit No. **[insert number]** and stating the amount of the demand; and
2. One of the following statements signed by an authorized representative or officer of Beneficiary:
 - A. “Pursuant to the terms of that certain **[insert name of the agreement]** (the “Agreement”), dated **[insert date of the Agreement]**, between Beneficiary and **[insert name of Seller under the Agreement]**, Beneficiary is entitled to draw under Letter of Credit No. **[insert number]** amounts owed by **[insert name of Seller under the Agreement]** under the Agreement; or
 - B. “Letter of Credit No. **[insert number]** will expire in thirty (30) days or less and **[insert name of Seller under the Agreement]** has not provided replacement security acceptable to Beneficiary.

Special Conditions:

1. Partial and multiple drawings under this Letter of Credit are allowed;
2. All banking charges associated with this Letter of Credit are for the account of the Applicant;
3. This Letter of Credit is not transferable;
4. A drawing for an amount greater than the Letter of Credit Amount is allowed, however, payment shall not exceed the Letter of Credit Amount; and
5. The Expiry Date of this Letter of Credit shall be automatically extended (without an amendment hereto) for a period of one (1) year from the Expiry Date or any future Expiry Date, unless **[insert name of Seller under the Agreement]** has provided replacement security acceptable to Beneficiary, or Beneficiary has returned this Letter of Credit to **[insert name of Seller under the Agreement]** prior to the Expiry Date.

We engage with you that drafts drawn under and in compliance with the terms of this Letter of Credit will be duly honored upon presentation, on or before the Expiry Date (or after the Expiry Date as provided below), at our offices at **[insert issuing bank's address for drawings]**.

All demands for payment shall be made by presentation of originals or copies of documents; or by facsimile transmission of documents to **[insert fax number]**, Attention: **[insert name of issuing bank's receiving department]**, with originals or copies of documents to follow by overnight mail. If presentation is made by facsimile transmission, you may contact us at **[insert phone number]** to confirm our receipt of the transmission. Your failure to seek such a telephone confirmation does not affect our obligation to honor such a presentation.

Our payments against complying presentations under this Letter of Credit will be made no later than on the sixth (6th) banking day following a complying presentation.

Except as stated herein, this Letter of Credit is not subject to any condition or qualification. It is our individual obligation, which is not contingent upon reimbursement and is not affected by any agreement, document, or instrument between us and the Applicant or between the Beneficiary and the Applicant or any other party.

Except as otherwise specifically stated herein, this Letter of Credit is subject to and governed by the *Uniform Customs and Practice for Documentary Credits, 2007 Revision*, International Chamber of Commerce (ICC) Publication No. 600 (the "UCP 600"); provided that, if this Letter of Credit expires during an interruption of our business as described in Article 36 of the UCP 600, we will honor drafts presented in compliance with this Letter of Credit within thirty (30) days after the resumption of our business and effect payment accordingly.

The law of the State of New York shall apply to any matters not covered by the UCP 600.

For telephone assistance regarding this Letter of Credit, please contact us at **[insert number and any other necessary details]**.

Very truly yours,

[insert name of issuing bank]

By: _____
Authorized Signature

Name: _____ **[print or type name]**

Title: _____

Exhibit A SIGHT DRAFT

TO
[INSERT NAME AND ADDRESS OF PAYING BANK]

AMOUNT: \$ _____ DATE: _____

AT SIGHT OF THIS DEMAND PAY TO THE ORDER OF PACIFIC GAS AND ELECTRIC COMPANY THE AMOUNT OF U.S.\$ _____ (_____ U.S. DOLLARS)

DRAWN UNDER [INSERT NAME OF ISSUING BANK] LETTER OF CREDIT NO. XXXXXX.

REMIT FUNDS AS FOLLOWS:

[INSERT PAYMENT INSTRUCTIONS]

DRAWER

BY: _____
NAME AND TITLE

APPENDIX II

INITIAL ENERGY DELIVERY DATE CONFIRMATION LETTER

In accordance with the terms of that certain Power Purchase Agreement dated _____ (“Agreement”) by and between _____ (“Buyer”) and _____ (“Seller”), this letter (“Initial Energy Delivery Date Confirmation Letter”) serves to document the Parties’ further agreement that (i) the Conditions Precedent to the occurrence of the Initial Energy Delivery Date have been satisfied, and (ii) Seller has scheduled and Buyer has received the Product, as specified in the Agreement, as of this _____ day of _____, _____ (the “Initial Energy Delivery Date”). All capitalized terms not defined herein shall have the meaning set forth in the Agreement.

Seller represents to Buyer that it has been granted status as an Exempt Wholesale Generator. Additionally Seller provides the following FERC Tariff information for reference purposes only:

Tariff: Dated: Docket Number:

IN WITNESS WHEREOF, each Party has caused this Initial Energy Delivery Date Confirmation Letter to be duly executed by its authorized representative as of the date of last signature provided below:

**SHILOH IV WIND PROJECT, LLC,
a Delaware limited liability company**

PACIFIC GAS AND ELECTRIC COMPANY

Signature: _____	Signature: _____
Name: _____	Name: _____
Title: _____	Title: _____
Date: _____	Date: _____

APPENDIX III

MILESTONES SCHEDULE

Identify Milestone	Date for Completion
Revised LGIA Executed	August 15, 2011
EPC Agreement Executed	March 1, 2012
Decommissioning Started	March 15, 2012
Final Land Control	June 15, 2012
Guaranteed Construction Start Date	July 1, 2012
Guaranteed Commercial Operation Date	December 31, 2012

APPENDIX III- Attachment A

Monthly Progress Report

For:

[Project Name]

By:

[Counterparty name] (“Seller”)

On:

[Report Date]

For month of:

[Report Month]

Provided to:

Pacific Gas and Electric Company (“Buyer”)

GENERAL PROJECT SPECIFICATIONS

Site Address, City, State:

Project Technology (*biomass, biogas, geothermal, hydro, solar PV, solar thermal, wind*):

Megawatt capacity:

Site size (*acres, square miles, square feet*):

1. INSTRUCTIONS

- 1.1. **Please complete the form and forward it to your PG&E Contract Manager according to the schedule specified in the Agreement.**
- 1.2. **You may add new information to the prior month's report without editing the prior month's information to reflect current status. For ease of review, please add a date in parenthesis in front of each new entry.**

i.e.: (11/4/09) Grading has started for the roads and turbine sites.

(10/4/09) Construction of maintenance buildings has been completed.

- 1.3. **See the Requirements for this report in Section 18.**

2. EXECUTIVE SUMMARY

Please provide a general Project overview statement.

3. MAJOR ACTIVITIES PERFORMED AND/OR COMPLETED - INCEPTION TO DATE

Please provide a cumulative summary of the major activities completed for each of the following aspects of the Project (provide details in subsequent sections of this report).

- 3.1. Milestones
- 3.2. Financing
- 3.3. Permitting and Governmental Approvals
- 3.4. Site Control
- 3.5. Design and Engineering
- 3.6. Major Equipment Procurement
- 3.7. Construction
- 3.8. Interconnection
- 3.9. Startup Testing and Commissioning

4. MAJOR ACTIVITIES PLANNED FOR NEXT MONTH

Please provide a summary of the major activities to be performed during the current month for each of the following aspects of the Project (provide details in subsequent sections of this report).

- 4.1. Milestones
- 4.2. Financing

4.3. Permitting and Governmental Approvals

4.4. Site Control

4.5. Design and Engineering

4.6. Major Equipment procurement

4.7. Construction

4.8. Interconnection

4.9. Startup Testing and Commissioning

5. MILESTONES

5.1. Milestone schedule

Please list all Milestones specified in the Agreement and state the current status of each.

Milestone	Milestone Date Specified in the Agreement	Status (e.g., on schedule, delayed due to [specify reason]; current expected completion date)

6. MILESTONE REMEDIAL ACTION PLAN (IF APPLICABLE)

If Seller has failed and/or expects to fail to achieve any Milestone, please explain in detail each of the following aspects of Seller's Remedial Action Plan.

6.1. Missed Milestone

6.2. Plans to achieve missed Milestone

6.3. Plans to achieve subsequent Milestones

6.4. Delays in engineering schedule and plans to remedy delays

6.5. Delays in major equipment procurement and plans to remedy delays

6.6. Delays in construction and interconnection schedule and plans to remedy

7. FINANCING

Please provide the schedule Seller intends to follow to obtain financing for the Project. Include information about each stage of financing. If Seller intends to pursue federal or state loans or grants, include information about each stage of the application process.

Activity (e.g., obtain \$xx for yy stage from zz)	Completion Date
	__/__/____ (expected / actual)
	__/__/____ (expected / actual)

8. PROJECT SCHEDULE

Please provide a copy of the current version of the overall Project development schedule (e.g., Work Breakdown Structure, Gantt chart, MS Project report, etc.). Include all major activities for Governmental Approvals, design and engineering, procurement, construction, interconnection and testing.

9. PERMITTING AND GOVERNMENTAL APPROVALS

9.1. Environmental Impact Review

Please provide information about the primary environmental impact review for the Project. Indicate whether dates are expected or actual.

Agency [e.g., the lead agency as required under the California Environmental Quality Act (CEQA)]	
Date of application/submission	__/__/____ (expected / actual)
Date application/submission deemed complete by agency	__/__/____ (expected / actual)
Date of initial study (if applicable)	__/__/____ (expected / actual)
Process (e.g., Notice of Exemption, Negative Declaration, Mitigated Negative Declaration, Environmental Impact Report)	
Date of Notice of Preparation	__/__/____ (expected / actual)
Date of Draft Negative Declaration – Mitigated Negative Declaration - Environmental Impact Report	__/__/____ (expected / actual)
Date Notice of Determination filed at CA Office of Planning and Research or County Clerk	__/__/____ (expected / actual)

9.2. Federal, State, Regional, County or Local Governmental Approvals

Please describe each of the major Governmental Approvals to be obtained by Seller and the status of each.

Agency / Approval <i>e.g., California Energy Commission (CEC) / Application for Certification (AFC)</i>	Status Summary <i>e.g., dates of application / hearing / notice / etc. (note whether dates are anticipated or actual); major activities (indicate whether planned, in progress and/or completed); primary reasons for possible delay, etc.</i>
<i>[name] County / Conditional Use Permit (CUP)</i>	

9.3. Governmental Approval activities recently performed

Please list all Governmental Approval activities that occurred since the previous report.

9.4. Governmental Approval activities expected during the current month

Please list all Governmental Approval activities that are expected to occur during the current month.

9.5. Governmental Approval Notices received from EPC Contractor

Please attach to this Monthly Progress Report copies of any notices related to Governmental Approval activities received since the previous report, whether from EPC Contractor or directly from Governmental Agencies.

10. SITE CONTROL

10.1. Site control schedule

If not obtained prior to the execution of the Agreement, please provide the schedule Seller intends to follow to obtain control of the Project Site (e.g., purchase, lease).

Activity	Completion Date
	__/__/____ (expected / actual)
	__/__/____ (expected / actual)

10.2. Site Control activities recently performed

Please explain in detail the property acquisition activities that were performed since the previous report.

10.3. Site Control activities expected during the current month.

Please explain in detail the Site control activities that are expected to be performed during the current month.

11. DESIGN and ENGINEERING

11.1. Design and engineering schedule

Please provide the name of the EPC Contractor, the date of execution of the EPC Contract, and the date of issuance of a full notice to proceed (or equivalent).

Please list all major design and engineering activities, both planned and completed, to be performed by Seller and the EPC Contractor.

Name of EPC Contractor / Subcontractor	Activity	Completion Date
		__/__/____ (expected / actual)
		__/__/____ (expected / actual)

11.2. Design and engineering activities recently performed

Please explain in detail the design and engineering activities that were performed since the previous report.

11.3. Design and engineering activities expected during the current month

Please explain in detail the design and engineering activities that are expected to be performed during the current month.

12. MAJOR EQUIPMENT PROCUREMENT

12.1. Major equipment to be procured

Please list all major equipment to be procured by Seller or the EPC Contractor.

Equipment Description	Manufacturer	Delivery Date (indicate whether expected or actual)	Installation Date (indicate whether expected or actual)
		__/__/____ (expected / actual)	__/__/____ (expected / actual)
		__/__/____ (expected / actual)	__/__/____ (expected / actual)

Equipment Description	No. Ordered	No. Made	No. On-Site	No. Installed	No. Tested

12.2. Major Equipment procurement activities recently performed

Please explain in detail the major equipment procurement activities that were performed since the previous report.

12.3. Major Equipment procurement activities expected during the current month

Please explain in detail the major equipment procurement activities that are expected to be performed during the current month.

13. CONSTRUCTION

13.1. Construction activities

Please list all major construction activities, both planned and completed, to be performed by Seller or the EPC contractor.

Activity	EPC Contractor / Subcontractor	Completion Date
		__/__/____ (expected / actual)
		__/__/____ (expected / actual)

13.2. Construction activities recently performed

Please explain in detail the construction activities that were performed since the previous report.

13.3. Construction activities expected during the current month

Please explain in detail the construction activities are expected to be performed during the current month.

13.4. EPC Contractor Monthly Progress Report.

Please attach a copy of the Monthly Progress Reports received since the previous report from the EPC Contractor pursuant to the construction contract between Seller and EPC Contractor, certified by the EPC Contractor as being true and correct as of the date issued.

14. INTERCONNECTION AND TRANSMISSION

14.1. Interconnection activities

Please list all major interconnection activities, both planned and completed, to be performed by Seller or the EPC Contractor.

Activity	Name of EPC Contractor / Subcontractor	Completion Date
		__/__/____ (expected / actual)
		__/__/____ (expected / actual)

14.2. Interconnection activities recently performed

Please explain in detail the interconnection activities that were performed since the previous report.

14.3. Interconnection activities expected during the current month

Please explain in detail the interconnection activities that are expected to be performed during the current month.

15. STARTUP TESTING AND COMMISSIONING

15.1. Startup testing and commissioning activities

Please list all major startup testing and commissioning activities, both planned and completed, to be performed by Seller or the EPC Contractor.

Activity	Name of EPC Contractor / Subcontractor	Completion Date
		__/__/____ (expected / actual)
		__/__/____ (expected / actual)

15.2. Startup testing and commissioning activities recently performed

Please explain in detail the startup testing and commissioning activities that were performed since the previous report.

15.3. Startup testing and commissioning activities expected during the current month

Please explain in detail the startup testing and commissioning activities that are expected to be performed during the current month.

16. SAFETY AND HEALTH REPORT

16.1. Accidents

Please describe all Project-related accidents reported since the previous report.

16.2. Work stoppages

Please describe all Project-related work stoppages that occurred since the previous report.

Please describe the effect of work stoppages on the Project schedule.

17. CERTIFICATION

I, _____, on behalf of and as an authorized representative of [_____], do hereby certify that any and all information contained in this Monthly Progress Report is true and accurate, and reflects, to the best of my knowledge, the current status of the construction of the Units as of the date specified below.

By: _____

Name: _____

Title: _____

Date: _____

18. REQUIREMENTS

Any capitalized terms used in this report which are not defined herein shall have the meaning ascribed to them in the Power Purchase Agreement by and between , (“Seller”) and Pacific Gas and Electric Company dated _____, (the “Agreement”).

In addition to the Remedial Action Plan requirement set forth in Section 3.9(c) of the Agreement, Seller shall review the status of each Milestone of the construction schedule for the Units and related Project and identify such matters referenced in clauses (i)-(v) below as known to Seller and which in Seller’s reasonable judgment are expected to adversely affect the schedule, and with respect to any such matters, shall state the actions which Seller intends to take to ensure that the Milestones will be attained by their required dates. Such matters may include, but shall not be limited to:

- (i) Any material matter or issue arising in connection with a Governmental Approval, or compliance therewith, with respect to which there is an actual or threatened dispute over the interpretation of a Law, actual or threatened opposition to the granting of a necessary Governmental Approval, any organized public opposition, any action or expenditure required for compliance or obtaining approval that Seller is unwilling to take or make, or in each case which could reasonably be expected to materially threaten or prevent financing of the Units or related Project, attaining any Milestone, or obtaining any contemplated agreements with other parties which are necessary for attaining any Milestone or which otherwise reasonably could be expected to materially threaten Seller’s ability to attain any Milestone.
- (ii) Any development or event in the financial markets or the independent power industry, any change in taxation or accounting standards or practices or in Seller’s business or prospects which reasonably could be expected to materially threaten financing of the Units or related Project, attainment of any Milestone or materially threaten any contemplated agreements with other parties which are necessary for attaining any Milestone or could otherwise reasonably be expected to materially threaten Seller’s ability to attain any Milestone;
- (iii) A change in, or discovery by Seller of, any legal or regulatory requirement which would reasonably be expected to materially threaten Seller’s ability to attain any Milestone;
- (iv) Any material change in the Seller’s schedule for initiating or completing any material aspect of Project;
- (v) The status of any matter or issue identified as outstanding in any prior Monthly Progress Report and any material change in the Seller’s proposed actions to remedy or overcome such matter or issue.

Seller shall complete, certify, and deliver this form of Monthly Progress Report to Buyer, together with all attachments and exhibits.

For the purpose of this report, “EPC Contractor” means the contractor responsible for engineering, procurement and construction of the Project, including Seller if acting as contractor, and including all subcontractors.

APPENDIX IV

PROJECT DESCRIPTION

Project name: *Shiloh IV Wind Project, LLC*

Project Site name: *Shiloh IV*

Project physical address:

In the Montezuma Hills of Solano County, CA approximately 11 miles south east of Fairfield, CA and approximately 19 miles south of Dixon, CA.

GPS Coordinates:

*38° 7' 58.00" N
121° 51' 3.65" W*

Total number of Units at the generating facility (committed and not committed to Buyer):

No greater than Fifty (50) wind turbine generators; the Units are composed of either MM92 2.0/2.05 MW turbines, Vestas v90 2.0MW turbines or GE 1.5MW turbines.

Technology Type: *Wind Energy*

Physical Interconnection Point of Project:

The interconnection diagram below describes the exact location of the point of interconnection for Shiloh IV, in the figure referred to as 'Shiloh IIIB':

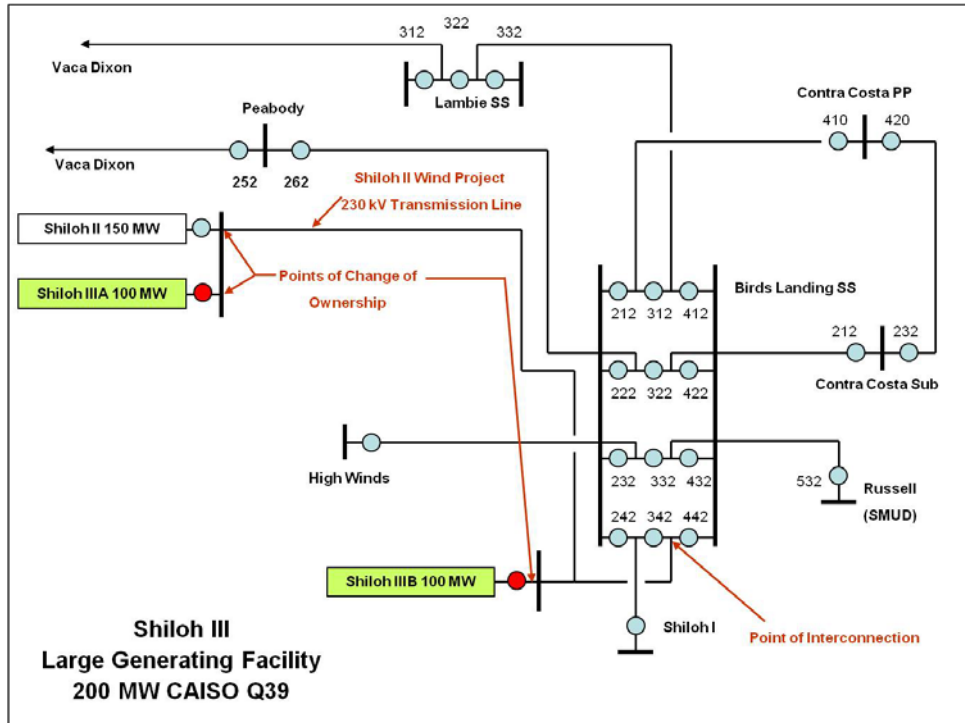

Service Territory of Project: *Pacific Gas and Electric*

Substation: *Birds Landing Switching Station*

The net Capacity of the Project: *100MW (unless modified per the terms of the Agreement)*

The term “Site” as defined in the Agreement means the following parcel description upon which the Project is located:

Land Owner's Name	APN	Acreage
Anderson, Edward A Jr Trust	0090-070-310	252.79
Anderson, Edward A Jr Trust	0090-090-350	231.67
Anderson, Eric Ian	0090-090-230	161.27
Anderson, Jeanie	0090-090-300	22.27
Anderson, Jeanie	0090-090-310	25.12
Anderson, Jeanie	0090-100-020	100.60
Engel Bros, et al	0048-060-100	194.71(aprox. 80)
Coco Properties LLC	0048-060-090	24.29
Coco Properties LLC	0090-090-220	154.73(aprox. 80)
Coco Properties LLC	0090-090-260	280.29(aprox. 245)
Coco Properties LLC	0090-090-270	27.71
Coco Properties LLC	0090-090-280	326.55(aprox. 280)
Coco Properties LLC	0090-090-290	52.20
Coco Properties LLC	0090-100-040	20.00
Hale Trust	0090-090-240	23.01
Hale Trust	0090-090-250	242.99(aprox. 182)
Hale Trust	0090-090-180	131.43
Stewart Thomas W, et al	0048-060-180	612.58
Stewart Thomas W, et al	0048-070-340	106.78
Stewart Thomas W, et al	0090-070-070	131.50
Stewart Thomas W, et al	0090-090-010	190.35
Zadwick Kenneth A & Dolores E	0048-070-240	100.64
Fuller, Elliot	0048-050-070	202.39
McCosker, Daryl	0048-050-330	152.69

Preliminary layout for Shiloh IV:

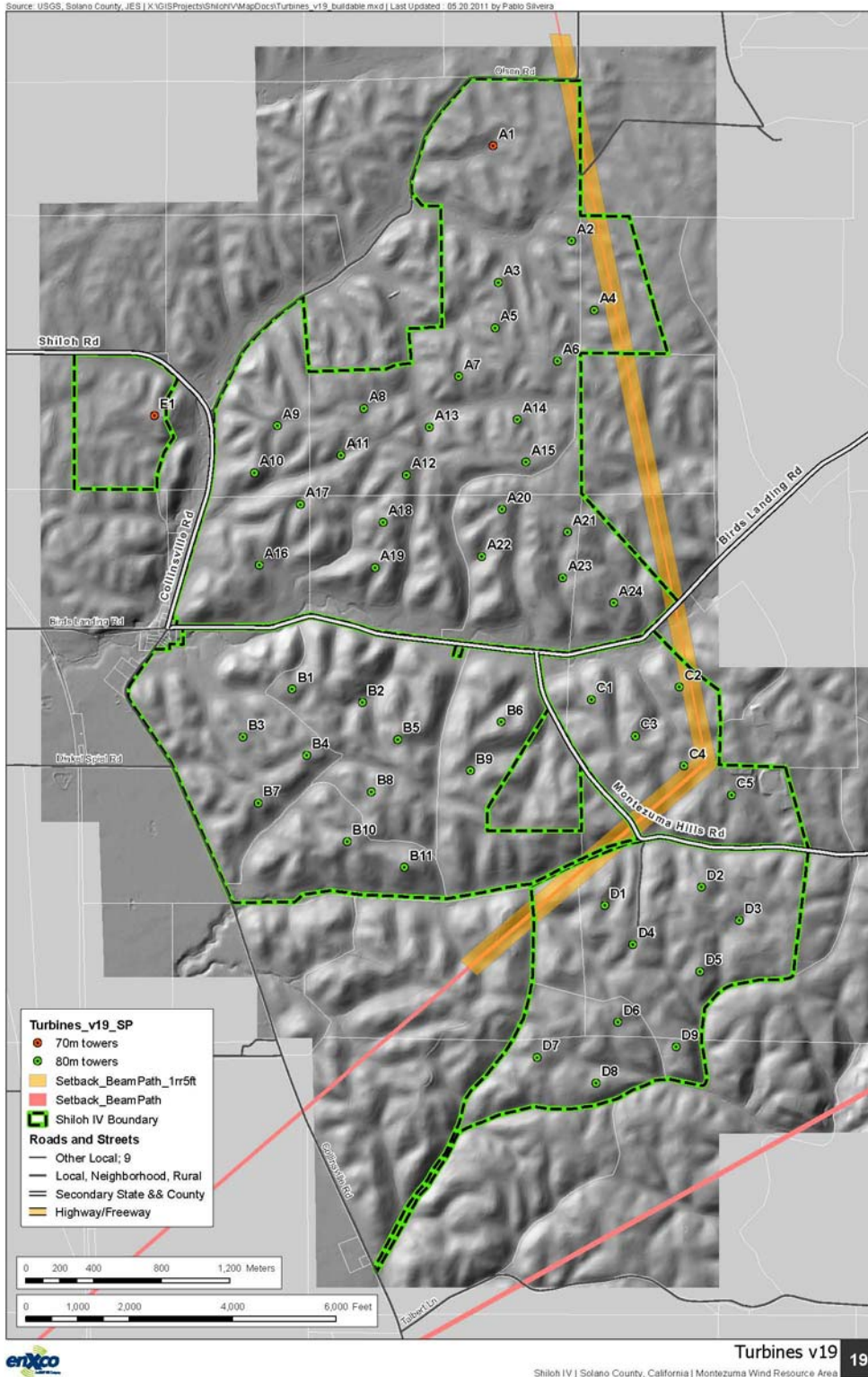

APPENDIX V

DELIVERY TERM CONTRACT QUANTITY SCHEDULE

Buyer and Seller agree that the Contract Quantity set forth below is subject to adjustment, in accordance with Section 3.1(e)(i) of the Agreement. The Contract Quantity set forth below is based on a Contract Capacity of 100 MW:

Contract Year	Contract Quantity
Years 1-20	271,814 MWh
Year 21	266,378 MWh
Year 22	261,050 MWh
Year 23	255,829 MWh
Year 24	250,713 MWh
Year 25	245,698 MWh

APPENDIX VI

**CONSTRUCTION START AND COMMERCIAL OPERATION
CERTIFICATION FORMS AND PROCEDURES**

Appendix VI-1: CONSTRUCTION START FORM OF CERTIFICATION

Appendix VI-2: COMMERCIAL OPERATION CERTIFICATION FORM AND PROCEDURES

APPENDIX VI-1

**CONSTRUCTION START
FORM OF CERTIFICATION**

This certification (“Certification”) of the Construction Start Date is delivered by Shiloh IV Wind Project, LLC (“Seller”) to Pacific Gas and Electric Company (“Buyer”) in accordance with the terms of that certain Power Purchase Agreement dated _____ (“Agreement”) by and between Seller and Buyer. All capitalized terms used in this Certification but not otherwise defined herein shall have the respective meanings assigned to such terms in the Agreement. Seller hereby certifies and represents to Buyer the following:

Seller hereby certifies and represents to Buyer the following:

1. The contract between Seller and the EPC Contractor for construction of the Project (the “Contract”) has been executed by each of Seller and the EPC Contractor;
2. The Notice to Proceed has been delivered by Seller to the EPC Contractor with a copy provided to Buyer; and
3. There are no conditions, delays or waiting periods set forth in the Contract or in the Notice to Proceed that in the reasonable judgment of the Seller would result in Seller’s failure to achieve the Guaranteed Project Milestones.

IN WITNESS WHEREOF, Seller has caused this Certificate of Construction Start to be duly executed by its authorized representative as of the date provided below:

**SHILOH IV WIND PROJECT, LLC, a
Delaware limited liability company**

By: _____
Name: _____
Title: _____
Date: _____

APPENDIX VI-2

COMMERCIAL OPERATION CERTIFICATION PROCEDURE

In accordance with the terms of that certain Power Purchase Agreement dated _____, 2011 (“Agreement”) by and between Pacific Gas and Electric Company (“Buyer”) and Shiloh IV Wind Project, LLC (“Seller”) to declare and recognize the Commercial Operation Date of the Project, Seller shall notify Buyer that the Project is operating and able to produce and deliver Delivered Energy to the CAISO in accordance with the terms of the Agreement by delivering a Certificate of Commercial Operation in the form of Appendix VI-2, Attachment A, from a Licensed Professional Engineer with respect to the Project’s ability to deliver the Product. Buyer shall accept such certification satisfying the requirements indicated below. All terms not defined herein shall have the meaning set forth in the Agreement. The Certificate of Commercial Operation shall be submitted by Seller, and supported by the following:

1. A statement that equipment sufficient to generate the total installed power capacity of the Project at unity power factor and a power output of at least [one hundred (100) MW] [or] [insert amount in MW, not less than 90 MW in accordance with Section 3.9(c)(iv)(C) of the Agreement] has been erected in accordance with the manufacturer’s specifications (“Initial Mechanical Completion”).
2. A statement that the electrical collection system related to the wind turbines comprising the total installed power capacity referenced in (1) above is substantially complete (subject to completion of punch-list items), functional, and energized for the Project.
3. A statement that the substation for the Project is substantially complete (subject to completion of punch-list items) and capable of delivering the Product.
4. A statement signed by the Licensed Professional Engineer that the Wind Turbines Initial Commissioning Completion has been achieved for those wind turbines that have achieved Initial Mechanical Completion. “Wind Turbines Initial Commissioning Completion” for Commercial Operation is achieved when the electrical and control systems have been energized and tested in accordance with the manufacturer’s specifications and the wind turbines are released by the manufacturer for electrical generation of power.
5. A statement that the Project is operational and interconnected with the CAISO Grid and released by the CAISO for unrestricted operation and capable of delivering Delivered Energy through the permanent Interconnection Facilities for the Project.
6. If Seller has provided a Capacity Reduction Notice in accordance with Section 3.9(c)(iv)(C) of the Agreement, then a statement setting forth the (i) Contract Capacity, (ii) the Contract Quantity and (iii) Delivery Term Security each revised to reflect adjustments to the Contract Capacity.

IN WITNESS WHEREOF, the undersigned has executed this Officer’s Certificate on behalf of the Seller as of the ___ day of _____ 20__.

**SHILOH IV WIND PROJECT, LLC, a
Delaware limited liability company**

By: _____
Name: _____
Title: _____

APPENDIX VI-2 –Attachment A

**COMMERCIAL OPERATION
FORM OF CERTIFICATION**

This certification (“Certification”) of Commercial Operation is delivered by Shiloh IV Wind Project, LLC (“Seller”) to Pacific Gas and Electric Company (“Buyer”) in accordance with the terms of that certain Power Purchase Agreement dated _____ (“Agreement”) by and between Seller and Buyer. All capitalized terms used in this Certification but not otherwise defined herein shall have the respective meanings assigned to such terms in the Agreement. Seller hereby certifies and represents to Buyer the following:

1. Seller has successfully completed completion testing of the Project which is required by the Project’s Governmental Approvals, the interconnection agreement, CEC Eligible Renewable Energy Resource certification requirements, and Seller’s construction and operating agreements;
2. all relevant manufacturers’ warranties for the commencement of Commercial Operation are in effect;
3. Seller has executed all agreements and made all arrangements necessary to deliver the Product from the Project to the Delivery Point safely and reliably in compliance with the provisions of the Agreement;
4. all Delivery Term Security arrangements have been established in a form and in the amounts sufficient to meet the requirements of Section 8.4(a)(iii) of the Agreement;
5. the insurance coverage requirements of Section 10.10 of the Agreement have been satisfied;
6. all Governmental Approvals required to be obtained from any Governmental Authority to operate the Project and sell the Products in compliance with applicable law and this Agreement have been obtained and are in full force and effect; and
7. Commercial Operation has occurred.

IN WITNESS WHEREOF, the undersigned has executed this Officer’s Certificate on behalf of the Seller as of the ___ day of _____ 20__.

**SHILOH IV WIND PROJECT, LLC, a
Delaware limited liability company**

By: _____
Name: _____
Title: _____

APPENDIX VII

GEP DAMAGES CALCULATION

In accordance with the provisions in Section 3.1(e)(ii), GEP Damages means the liquidated damages payment due by Seller to Buyer, calculated as follows:

$$[(A - B) \times (C - D)]$$

Where:

A = the Guaranteed Energy Production for the Performance Measurement Period, in MWh

B = Sum of Delivered Energy over the Performance Measurement Period, in MWh

C = Replacement Price for the Performance Measurement Period, in \$/MWh, reflecting the sum of (a) the simple average of the simple average of the Day Ahead Integrated Forward Market hourly price, as published by the CAISO, for the Existing Zone Generation Trading Hub, in which the PNode resides, plus (b) \$50/MWh

D = the unweighted Contract Price specified in Section 4.1 for the Performance Measurement Period, in \$/MWh

The Parties agree that in the above calculation of GEP Damages, the result of "(C-D)" shall not be less than \$20/MWh.

APPENDIX VIII

NOTIFICATION REQUIREMENTS FOR AVAILABLE CAPACITY AND PROJECT OUTAGES

A. NOTIFICATION REQUIREMENTS FOR ROUTINE START-UP AND SHUTDOWNS

Prior to paralleling or after disconnecting from the electric system, notify the applicable Participating Transmission Owner's (PTO) switching center

- Call the applicable Participating Transmission Owner's (PTO) switching center and advise of the intent to parallel.
- Call the applicable Participating Transmission Owner's (PTO) switching center after the Unit has been paralleled and report the parallel time and intended Unit output.
- Call the applicable Participant Transmission Owner's (PTO) switching center after any routine separation.

B. SUBMISSION OF AVAILABLE CAPACITY AND PLANNED OUTAGES

1. Submit information by posting to PG&E's Power Procurement Information Center, which is located at www.pge.com under "B2B" at the bottom of the home page. After selecting "B2B" at the bottom of the page, select "Wholesale Power" in the center of the next page. Then select "Electric Procurement" along the left banner of the next page. After selecting the "Power Procurement Information Center" icon in the middle of the page, you will be required to enter a username and password, which will be assigned to you by PG&E's Bilateral Settlements Group.
2. If the website is unavailable, implement the procedures set forth below:
 - a. **For all email correspondence, enter the following in the email subject field: Delivery Date Range, Contract Name, Email Purpose (For example: "dd/mm/yyyy through dd/mm/yyyy XYZ Company Project #2 Daily Forecast of Available Capacity")**
 - b. For Annual Forecasts of Available Capacity, email to DAenergy@pge.com and [Bilat Settlements@pge.com](mailto:BilatSettlements@pge.com).
 - c. For Monthly and Daily Forecasts of Available Capacity, email to DAenergy@pge.com.
 - d. For Daily Forecasts of Available Capacity after fourteen (14) hours before the WECC Preschedule Day, but before the CAISO deadline for submitting Day-Ahead Schedules, call primary phone (415) 973-6222 or backup phone (415) 973-4500. Also send email to DAenergy@pge.com.
 - e. For Hourly Forecasts of Available Capacity, call PG&E's Real Time Desk at (415) 973-4500 and email to RealTime@pge.com.

- f. For Planned Outages and Prolonged Outages, complete the specifics below and submit by email to PGOutageCoordination@pge.com, DAenergy@pge.com and Bilat_Settlements@pge.com.

i. Email subject Field: dd/mm/yyyy through dd/mm/yyyy XYZ Company Project #2 Outage Notification

ii. Email body:

- 1. Type of Outage: Planned Outage, Forced Outage, Prolonged Outage*
- 2. Start Date and Start Time*
- 3. Estimated or Actual End Date and End Time*
- 4. Date and time when reported to PG&E and name(s) of PG&E representative(s) contacted*
- 5. Text description of additional information as needed, including, but not limited to, changes to a Planned Outage, Prolonged Outage or Forced Outage.*

C. FORCED OUTAGE REPORTING

1. Forced Outages – Seller shall notify PG&E Merchant Generation desk verbally within 10 minutes of event or as soon as reasonably possible, after the safety of all personnel and securing of all facility equipment.
 - a. Verbal notification shall include time of forced outage, cause, current availability and estimated return date and time.
 - b. After verbally notifying PG&E Merchant Generation desk of the forced outage, Seller shall also put forth commercially reasonable efforts to notify PG&E Settlements via PG&E’s electronic website “PPIC”.
 - c. If the PPIC website is unavailable, submit the following information via email to Bilat_Settlements@pge.com.

i. Email subject Field: dd/mm/yyyy through dd/mm/yyyy XYZ Company Project #2 Outage Notification

ii. Email body:

- 1. Type of Outage: Planned Outage, Forced Outage, Prolonged Outage*
- 2. Start Date and Start Time*
- 3. Estimated or Actual End Date and End Time*

- 4. Date and time when reported to PG&E and name(s) of PG&E representative(s) contacted***
- 5. Text description of additional information as needed, including, but not limited to, changes to a Planned Outage, Prolonged Outage or Forced Outage.***

**APPENDIX IX
CERTIFICATION OF THIRD PARTY AGREEMENT**

The following certification is delivered by Shiloh IV Wind Project, LLC (“Seller”) to Pacific Gas and Electric Company (“Buyer”) in accordance with Section 11.2(b) of that certain Power Purchase Agreement, dated _____, 2011, between Seller and Buyer (as amended, the “PPA”). Based on Seller’s analysis of the key contract terms listed below in the PPA (the “Contract Terms”), and the similar terms and conditions in [describe third party agreement] (the “Proposed Third Party Agreement”), I [insert name, company, and title] certify that under the terms and conditions of the Proposed Third Party Agreement Seller does not expect to receive a lower rate of return on its development and operation of the Project than the rate of return projected by Seller as a result of selling the Product produced by the Project to Buyer under the First Offer pursuant to Section _____ of the PPA.

Capitalized terms not defined herein shall have the meaning set forth in the PPA.

Contract Terms:

1. MW amount of Contract Capacity (including flexibility to change Contract Capacity prior to COD)
2. Product
3. Guaranteed Commercial Operation Date
4. Delivery Term
5. Delivery Point
6. Contract Price (including escalation)
7. Contract Quantity - expected annual volume of deliveries inclusive of outages
8. Guaranteed Energy Production target - minimum volume of delivery on an annual basis
9. Security Requirements applicable to Seller
10. Curtailment and scheduling provisions
11. Other key contract terms

IN WITNESS WHEREOF, the undersigned has executed this certificate this ___ day of [_____].

By: _____

Name:

Title:

APPENDIX X

RESOURCE ADEQUACY

1. Seller and Buyer agree that throughout the Delivery Term the Parties shall take all commercially reasonable actions and execute any and all documents or instruments reasonably necessary to enable Buyer to use the RA Capacity to satisfy Buyer's Resource Adequacy Requirements. Such commercially reasonable actions may include, but are not limited to, the following:
 - A. Cooperating with and encouraging the regional entity, including the CAISO, if applicable, responsible for Resource Adequacy administration to certify or qualify the Contract Capacity for Resource Adequacy Requirements purposes. This includes following requirements the CAISO and/or CPUC has established and may establish in the future, including calculation of RA Capacity over all hours required for Resource Adequacy Requirement eligibility, and delivery of the RA Capacity to the Interconnection Point; and
 - B. Negotiating in good faith to make necessary amendments, if any, to this Agreement to conform this Agreement to subsequent clarifications, revisions or decisions of the CPUC or any other entity, including the CAISO, with respect to Resource Adequacy.
2. Seller shall comply with the Resource Adequacy reporting requirements set forth in Section 40 of the CAISO Tariff as may be changed from time to time, including but not limited to the following:
 - A. Taking all actions to register the Project with the CAISO to ensure that the Project's Capacity Attributes and/or Contract Capacity is able to be recognized and counted as RA Capacity;
 - B. Coordinating with Buyer on the submission to the CAISO of the Monthly Resource Adequacy Plan, as defined in the CAISO Tariff;
 - C. Complying with the dispatch requirements applicable to the Project's resource type, as set forth in Section 40 of the CAISO Tariff; and
 - D. Complying with the applicable reporting requirements, such as submitting Supply Plans to the CAISO.
3. RA Capacity Delivery Point. The delivery point for the Project, with respect to Buyer's Resource Adequacy Requirements, shall be the Interconnection Point for the Project.

APPENDIX XI

NOTICES LIST

Name: Shiloh IV Wind Project, LLC, a Delaware limited liability company (“Seller”)

All Notices:

Delivery Address:
15445 Innovation Drive
San Diego, California 92128

Mail Address: (if different from above)
As above

Attn: Vice President, Generation

Phone: (760) 740-7022
Facsimile: (760) 740-7030

DUNS:
Federal Tax ID Number: 90-0072316

Invoices:

Attn: Bill Mason (billm@enxco.com)

Phone: (760) 740-7022
Facsimile: (760) 740-7030

Scheduling:

Attn: Lyrae Stage (lyraes@enxco.com)
Phone: (507) 677-2274
Facsimile: (507) 677-2560

Payments:

Attn: Bill Mason (billm@enxco.com)

Phone: (760) 740-7022
Facsimile: (760) 740-7030

Wire Transfer:

BNK:
ABA:
ACCT:

Credit and Collections:

Attn: Bill Mason (billm@enxco.com)

Phone: (760) 740-7022

Name: Pacific Gas and Electric Company, a California corporation (“Buyer” or “PG&E”)

All Notices:

Delivery Address:
77 Beale Street, Mail Code N12E
San Francisco, CA 94105-1702

Mail Address:

P.O. Box 770000, Mail Code N12E
San Francisco, CA 94177
Attn: Candice Chan (CWW9@pge.com)
Director, Contract Mgmt & Settlements
Phone: (415) 972-7780
Facsimile: (415) 972-5507

DUNS:
Federal Tax ID Number:

Invoices:

Attn: Azmat Mukhtar (ASM3@pge.com)
Manager, Bilateral Settlements
Phone: (415) 973-4277
Facsimile: (415) 973-2151

Scheduling:

Attn: Mike McDermott (m0mc@pge.com)
Phone: (415) 973-4072
Facsimile: (415) 973-0400

Payments:

Attn: Azmat Mukhtar (ASM3@pge.com)
Manager, Bilateral Settlements
Phone: (415) 973-4277
Facsimile: (415) 973-2151

Wire Transfer:

BNK:
ABA:
ACCT:

Credit and Collections:

Attn: Justice Awuku
Manager, Credit Risk Management
Phone: (415) 973-4414

Facsimile: (760) 740-7030

Facsimile: (415) 973-7301

With additional Notices of an Event of Default to:

Attn: General Counsel

Phone: (760) 740-7022

Facsimile: (760) 740-7030

Contract Manager:

Attn: Ted Yura (THY1@pge.com)

Manager, Contract Management

Phone: (415) 973-8660

Facsimile: (415) 972-5507

With additional Notices of an Event of Default to:

PG&E Law Department

Attn: Renewables Portfolio Standard attorney

Phone: (415) 973-4377

Facsimile: (415) 972-5952

APPENDIX XII

FORM OF CONSENT TO ASSIGNMENT

CONSENT AND AGREEMENT

This CONSENT AND AGREEMENT (“Consent and Agreement”) is entered into as of [_____, 2___], between PACIFIC GAS AND ELECTRIC COMPANY (“PG&E”), and [_____] , as collateral agent¹ (in such capacity, “Financing Provider”), for the benefit of various financial institutions (collectively, the “Secured Parties”) providing financing to [_____] (“Seller”). PG&E, Seller, and the Financing Provider shall each individually be referred to a “Party” and collectively as the “Parties”.

Recitals

A. Pursuant to that certain Power Purchase Agreement dated as of _____, 2___ (as amended, modified, supplemented or restated from time to time, as including all related agreements, instruments and documents, collectively, the “Assigned Agreement”) between PG&E and Seller, PG&E has agreed to purchase energy from Seller.

B. The Secured Parties have provided, or have agreed to provide, to Seller financing (including a financing lease) pursuant to one or more agreements (the “Financing Documents”), and require that Financing Provider be provided certain rights with respect to the “Assigned Agreement” and the “Assigned Agreement Accounts,” each as defined below, in connection with such financing.

C. In consideration for the execution and delivery of the Assigned Agreement, PG&E has agreed to enter into this Consent and Agreement for the benefit of Seller.

Agreement

1. Definitions. Any capitalized term used but not defined herein shall have the meaning specified for such term in the Assigned Agreement.
2. Consent. Subject to the terms and conditions below, PG&E consents to and approves the pledge and assignment by Seller to Financing Provider pursuant to the [Security Agreement] of (a) the Assigned Agreement, and (b) the accounts, revenues and proceeds of the Assigned Agreement (collectively, the “Assigned Agreement Accounts”).
3. Limitations on Assignment. Financing Provider acknowledges and confirms that, notwithstanding any provision to the contrary under applicable law or in any Financing Document executed by Seller, Financing Provider shall not assume, sell or otherwise dispose of the Assigned Agreement (whether by foreclosure sale, conveyance in lieu of foreclosure or otherwise) unless, on or before the date of any such assumption, sale or disposition, Financing Provider or any third party, as the case may be, assuming, purchasing or otherwise acquiring the Assigned Agreement (a) cures any and all defaults of Seller under the Assigned Agreement which are capable of being cured and which are not personal to the Seller, (b) executes and delivers to PG&E a written assumption of all of Seller’s rights and obligations under the Assigned Agreement in form and substance reasonably satisfactory to PG&E, (c) otherwise satisfies and

¹ This form assumes that a collateral agent will hold the security on behalf of a syndicate of lenders and therefore, the consent would be signed by the collateral agent in such capacity for the benefit of the secured parties. If that is not the case, please modify.

complies with all requirements of the Assigned Agreement, (d) provides such tax and enforceability assurance as PG&E may reasonably request, and (e) is a Permitted Transferee (as defined below). Financing Provider further acknowledges that the assignment of the Assigned Agreement and the Assigned Agreement Accounts is for security purposes only and that Financing Provider has no rights under the Assigned Agreement or the Assigned Agreement Accounts to enforce the provisions of the Assigned Agreement or the Assigned Agreement Accounts unless and until an event of default has occurred and is continuing under the Financing Documents between Seller and Financing Provider (a “Financing Default”), in which case Financing Provider shall be entitled to all of the rights and benefits and subject to all of the obligations which Seller then has or may have under the Assigned Agreement to the same extent and in the same manner as if Financing Provider were an original party to the Assigned Agreement.

“Permitted Transferee” means any person or entity who is reasonably acceptable to PG&E. Financing Provider may from time to time, following the occurrence of a Financing Default, notify PG&E in writing of the identity of a proposed transferee of the Assigned Agreement, which proposed transferee may include Financing Provider, in connection with the enforcement of Financing Provider’s rights under the Financing Documents, and PG&E shall, within thirty (30) business days of its receipt of such written notice, confirm to Financing Provider whether or not such proposed transferee is a “Permitted Transferee” (together with a written statement of the reason(s) for any negative determination) it being understood that if PG&E shall fail to so respond within such thirty (30) business day period such proposed transferee shall be deemed to be a “Permitted Transferee”.

4. Cure Rights.

(a) Notice to Financing Provider by PG&E. PG&E shall, concurrently with the delivery of any notice of an event of default under the Assigned Agreement (each, an “Event of Default”) to Seller (a “Default Notice”), provide a copy of such Default Notice to Financing Provider pursuant to Section 9(a) of this Consent and Agreement. In addition, Seller shall provide a copy of the Default Notice to Financing Provider the next business day after receipt from PG&E, independent of any agreement of PG&E to deliver such Default Notice.

(b) Cure Period Available to Financing Provider Prior to Any Termination by PG&E. Upon the occurrence of an Event of Default, subject to (i) the expiration of the relevant cure periods provided to Seller under the Assigned Agreement, and (ii) Section 4(a) above, PG&E shall not terminate the Assigned Agreement unless it or Seller provides Financing Provider with notice of the Event of Default and affords Financing Provider an Additional Cure Period (as defined below) to cure such Event of Default. For purposes of this Agreement “Additional Cure Period” means (i) with respect to a monetary default, ten (10) days in addition to the cure period (if any) provided to Seller in the Assigned Agreement, and (ii) with respect to a non-monetary default, thirty (30) days in addition to the cure period (if any) provided to Seller in the Assigned Agreement.

(c) Failure by PG&E to Deliver Default Notice. If neither PG&E nor Seller delivers a Default Notice to Financing Provider as provided in Section 4(a), the Financing Provider’s applicable cure period shall begin on the date on which notice of an Event of Default is delivered to Financing Provider by either PG&E or Seller. Except for a delay in the commencement of the cure period for Financing Provider and a delay in PG&E’s ability to terminate the Assigned Agreement (in each case only if both PG&E and Seller fail to deliver notice of an Event of Default to Financing Provider), failure of PG&E to deliver any Default Notice shall not waive

PG&E's right to take any action under the Assigned Agreement and will not subject PG&E to any damages or liability for failure to provide such notice.

(d) Extension for Foreclosure Proceedings. If possession of the Project (as defined in the Assigned Agreement) is necessary for Financing Provider to cure an Event of Default and Financing Provider commences foreclosure proceedings against Seller within thirty (30) days of receiving notice of an Event of Default from PG&E or Seller, whichever is received first, Financing Provider shall be allowed a reasonable additional period to complete such foreclosure proceedings, such period not to exceed ninety (90) days; provided, however, that Financing Provider shall provide a written notice to PG&E that it intends to commence foreclosure proceedings with respect to Seller within ten (10) business days of receiving a notice of such Event of Default from PG&E or Seller, whichever is received first. In the event Financing Provider succeeds to Seller's interest in the Project as a result of foreclosure proceedings, the Financing Provider or a purchaser or grantee pursuant to such foreclosure shall be subject to the requirements of Section 3 of this Consent and Agreement.

5. Setoffs and Deductions. Each of Seller and Financing Provider agrees that PG&E shall have the right to set off or deduct from payments due to Seller each and every amount due PG&E from Seller whether or not arising out of or in connection with the Assigned Agreement. Financing Provider further agrees that it takes the assignment for security purposes of the Assigned Agreement and the Assigned Agreement Accounts subject to any defenses or causes of action PG&E may have against Seller.

6. No Representation or Warranty. Seller and Financing Provider each recognizes and acknowledges that PG&E makes no representation or warranty, express or implied, that Seller has any right, title, or interest in the Assigned Agreement or as to the priority of the assignment for security purposes of the Assigned Agreement or the Assigned Agreement Accounts. Financing Provider is responsible for satisfying itself as to the existence and extent of Seller's right, title, and interest in the Assigned Agreement, and Financing Provider releases PG&E from any liability resulting from the assignment for security purposes of the Assigned Agreement and the Assigned Agreement Accounts.

7. Amendment to Assigned Agreement. Financing Provider acknowledges and agrees that PG&E may agree with Seller to modify or amend the Assigned Agreement, and that PG&E is not obligated to notify Financing Provider of any such amendment or modification to the Assigned Agreement. Financing Provider hereby releases PG&E from all liability arising out of or in connection with the making of any amendment or modification to the Assigned Agreement.

8. Payments under Assigned Agreement. PG&E shall make all payments due to Seller under the Assigned Agreement from and after the date hereof to [____], as depository agent, to ABA No. [____], Account No. [____], and Seller hereby irrevocably consents to any and all such payments being made in such manner. Each of Seller, PG&E and Financing Provider agrees that each such payment by PG&E to such depository agent of amounts due to Seller from PG&E under the Assigned Agreement shall satisfy PG&E's corresponding payment obligation under the Assigned Agreement.

9. Miscellaneous.

(a) Notices. All notices hereunder shall be in writing and shall be deemed received (i) at the close of business of the date of receipt, if delivered by hand or by facsimile or other electronic means, or (ii) when signed for by recipient, if sent registered or certified mail, postage

prepaid, provided such notice was properly addressed to the appropriate address indicated on the signature page hereof or to such other address as a party may designate by prior written notice to the other parties, at the address set forth below:

If to Financing Provider:

Name: _____
Address: _____

Attn: _____
Telephone: _____
Facsimile: _____
Email: _____

If to PG&E:

Name: _____
Address: _____

Attn: _____
Telephone: _____
Facsimile: _____
Email: _____

(b) No Assignment. This Consent and Agreement shall be binding upon and shall inure to the benefit of the successors and assigns of PG&E, and shall be binding on and inure to the benefit of the Financing Provider, the Secured Parties and their respective successors and permitted transferees and assigns under the [loan agreement] and [security agreement].

(c) No Modification. This Consent and Agreement is neither a modification of nor an amendment to the Assigned Agreement.

(d) Choice of Law. The parties hereto agree that this Consent and Agreement shall be construed and interpreted in accordance with the laws of the State of California, excluding any choice of law rules which may direct the application of the laws of another jurisdiction.

(e) No Waiver. No term, covenant or condition hereof shall be deemed waived and no breach excused unless such waiver or excuse shall be in writing and signed by the party claimed to have so waived or excused.

(f) Counterparts. This Consent and Agreement may be executed in one or more duplicate counterparts, and when executed and delivered by all the parties listed below, shall constitute a single binding agreement.

(g) No Third Party Beneficiaries. There are no third party beneficiaries to this Consent and Agreement.

(h) Severability. The invalidity or unenforceability of any provision of this Consent and Agreement shall not affect the validity or enforceability of any other provision of this Consent and Agreement, which shall remain in full force and effect.

(i) Amendments. This Consent and Agreement may be modified, amended, or rescinded only by writing expressly referring to this Consent and Agreement and signed by all parties hereto.

IN WITNESS WHEREOF, each of PG&E and Financing Provider has duly executed this Consent and Agreement as of the date first written above.

PACIFIC GAS AND ELECTRIC COMPANY
(PG&E)

By: _____
Name: _____
Title: _____

[_____] (Financing Provider), as collateral agent

By: _____
Name: _____
Title: _____

ACKNOWLEDGEMENT

The undersigned hereby acknowledges the Consent and Agreement set forth above, makes the agreements set forth therein as applicable to Seller, including the obligation of Seller to provide a copy of any Default Notice it receives from PG&E to Financing Provider the next business day after receipt by Seller, and confirms that the Financing Provider identified above and the Secured Parties have provided or are providing financing to the undersigned.

[_____] [name of Seller]

By: _____
Name: _____
Title: _____

APPENDIX XIII

SELLER DOCUMENTATION CONDITION PRECEDENT

Seller shall provide to Buyer, pursuant to the terms of Section 2.5(a)(v) of the Agreement, all of the following documentation no more than five (5) Business Days following the Execution Date:

1. A copy of each of (A) the articles of incorporation, certificate of incorporation, operating agreement or similar applicable organizational document of Seller and (B) the by-laws or other similar document of Seller (collectively, "Charter Documents") as in effect on the Execution Date.
2. A certificate signed by an authorized officer of Seller, dated the Execution Date, certifying (A) that attached thereto is a true and complete copy of the Charter Documents of the Seller, as in effect at all times from the date on which the resolutions referred to in clause (B) below were adopted to and including the date of such certificate; (B) that attached thereto is a true and complete copy of resolutions duly adopted by the board of directors (or other equivalent body) or evidence of all corporate or limited liability company action, as the case may be, of Seller, authorizing the execution, delivery and performance of this Agreement, and that such resolutions have not been modified, rescinded or amended and are in full force and effect, and (C) as to the name, incumbency and specimen signature of each officer of Seller executing this Agreement.
3. A certificate from the jurisdiction of Seller's incorporation or organization certifying that Seller is duly organized, validly existing and in good standing under the laws of such jurisdiction.
4. Evidence of Site control (e.g. lease with redacted price terms) satisfactory to Buyer.
5. Evidence of application for CEC Certification and Verification (pre-certification) satisfactory to Buyer.
6. A copy of the most recent financial statements (which may be unaudited) from Seller together with a certificate from the Chief Financial or equivalent officer of Seller, dated the Execution Date, to the effect that, to the best of such officer's knowledge, (A) such financial statements are true, complete and correct in all material respects and (B) there has been no material adverse change in the financial condition, operations, Properties, business or prospects of Seller since the date of such financial statements.

APPENDIX XIV

FORM OF ACTUAL AVAILABILITY REPORT

Pursuant to Section 3.1(l)(i), Seller shall prepare an Actual Availability Report in accordance with the procedures described in this Appendix XIV.

- (a) Availability Workbook. Seller shall (i) collect the measurement data, listed in (b) below, in one (1) or more Microsoft Excel Workbooks (the “Availability Workbook”) provided in a form and naming convention approved by Buyer and (ii) electronically send the Availability Workbook to an address provided by Buyer. The Actual Availability Report shall reflect the sum of the Settlement Interval Actual Available Capacity of all generators as measured by such generator’s internal turbine controller.
- (b) Log of Availability. The Availability Workbook shall be created on a single, dedicated Excel worksheet and shall be in the form of Attachment A to this Appendix XIV.

APPENDIX XIV Attachment A

Form of Actual Availability Report

[Seller]'s Actual Availability Report

All amounts are in MWs

Settlement Interval No.	Date	HE1	HE2	HE3	HE4	HE5	HE6	HE7	HE8	HE9	HE10	HE11	HE12	HE13	HE14	HE15	HE16	HE17	HE18	HE19	HE20	HE21	HE22	HE23	HE24
1	mm/dd/yyyy																								
2	mm/dd/yyyy																								
3	mm/dd/yyyy																								
4	mm/dd/yyyy																								
5	mm/dd/yyyy																								
6	mm/dd/yyyy																								
1	mm/dd/yyyy																								
2	mm/dd/yyyy																								
3	mm/dd/yyyy																								
4	mm/dd/yyyy																								
5	mm/dd/yyyy																								
6	mm/dd/yyyy																								
1	mm/dd/yyyy																								
2	mm/dd/yyyy																								
3	mm/dd/yyyy																								
4	mm/dd/yyyy																								
5	mm/dd/yyyy																								
6	mm/dd/yyyy																								

Date/Time of Submittal

Appendix XV
Telemetry Parameters for Wind or Solar Facility

Technology Type	Telemetry Parameters	Units	
Solar Photovoltaic	Back Panel Temperature	°C	
	Global Horizontal Irradiance	W/m ²	
	Plane of Array Irradiance (If PV is fixed) Direct Normal Irradiance (If PV is Tracking)	W/m ²	
	Wind Speed	m/s	
	Peak Wind Speed (Within 1 minute)	m/s	
	Wind Direction	Degrees	
	Ambient Air Temperature	°C	
	Dewpoint Air Temperature or Relative Humidity	°C	
	Horizontal Visibility	m	
	Precipitation (Rain Rate)	mm/hr	
	Precipitation (Running 30 day total)	mm	
	Barometric Pressure	Millibars or Hecto Pascals (HPa)	
	Solar Thermal or Solar Trough	Global Horizontal Irradiance	W/m ²
		Plane of Array Irradiance (If PV is fixed) Direct Normal Irradiance (If PV is Tracking)	W/m ²
Wind Speed		m/s	
Peak Wind Speed (Within 1 minute)		m/s	
Wind Direction		Degrees	
Ambient Air Temperature		°C	
Dewpoint Air Temperature or Relative Humidity		°C	
Horizontal Visibility		m	
Precipitation (Rain Rate)		mm/hr	
Precipitation (Running 30 day total)		mm	
Barometric Pressure		Millibars or Hecto Pascals (HPa)	
Wind		Wind Speed	m/s
		Peak Wind Speed (Within 1 minute)	m/s
	Wind Direction	Degrees	
	Wind Speed Standard Deviation	--	
	Wind Direction Standard Deviation	--	
	Barometric Pressure	Millibars or Hecto Pascals (HPa)	
	Ambient Temperature	°C	

APPENDIX XVI

Buyer Curtailment Orders

Operational Characteristics of Project for consideration in Buyer Curtailment Orders:

- Time required by Seller to reduce generation to the Dispatch Operating Point (as defined in the CAISO Tariff) upon receipt of a Buyer Curtailment Order delivered electronically to Seller's SCADA or equivalent control system: **10 Minutes**

SCADA / Equivalent Example (for illustrative purposes only): Buyer Curtailment Order received at 10:00 to reduce generation down to zero (0), Seller needs to be at zero (0) generation on or before 10:10.

- Time required by Seller to reduce generation to the Dispatch Operating Point (as defined in the CAISO Tariff) upon receipt of a Buyer Curtailment Order delivered via telephone or electronic mail: **20 Minutes**, though Seller will make reasonable best efforts to reach the Dispatch Operating Point within 10 minutes of instruction receipt.

Telephone / Electronic Mail Example (for illustrative purposes only): Buyer Curtailment Order received at 10:00 to reduce generation down to zero (0), Seller needs to be at zero (0) generation on or before 10:20.

- Minimum down time: **30 minutes**, except as follows:

Upon Buyer's request, minimum down time shall be:	Subject to the following maximum occurrences per Contract Year:
Between five (5) minutes and ten (10) minutes	10
Between ten (10) minutes and twenty (20) minutes	20
Between twenty (20) minutes and thirty (30) minutes	40

APPENDIX XVII

FORM OF LETTER OF CONCURRENCE

[Date]

[Name]

[Position]

[Company]

[Address]

Re: Letter of Concurrence Regarding Control of [Name] Facility

This letter sets forth the understanding of the degree of control exercised by Pacific Gas and Electric Company (“PG&E”) and [Company Name] with respect to [Facility Name (the “Facility”)] for the purposes of facilitating compliance with the requirements of the Federal Energy Regulatory Commission’s (“Commission”) Order No. 697.¹ Specifically, Order No. 697 requires that sellers filing an application for market-based rates, an updated market power analysis, or a required change in status report with regard to generation specify the party or parties they believe have control of the generation facility and extent to which each party holds control.² The Commission further requires that “a seller making such an affirmative statement seek a ‘letter of concurrence’ from other affected parties identifying the degree to which each party controls a facility and submit these letters with its filing.”³

PG&E and [Company Name] have executed a [power purchase and sale agreement (the “Agreement”)] with regard to the Facility. The Facility is a [XX] MW [description] facility located in [County, State]. Pursuant to the Agreement, [Company Name] maintains sole control of the Facility.

If you concur with the statements made in this letter, please countersign the letter and send a copy to me.

Best regards,

[Author]

[Position]

Pacific Gas and Electric Company

¹ *Market-Based Rates for Wholesale Sales of Electric Energy, Capacity and Ancillary Services by Public Utilities*, Order No. 697 at P 186-187, FERC Stats. & Regs. ¶ 31,252, *clarified*, 121 FERC ¶ 61,260 (2007), *order on reh’g*, Order No. 697-A, FERC Stats. & Regs. ¶ 31,268 (2008), *clarified*, 124 FERC ¶ 61,055 (2008), *order on reh’g*, Order No. 697-B, FERC Stats. & Regs. ¶ 31,285 (2008), *order on reh’g*, Order No. 697-C, FERC Stats. & Regs. ¶ 31,291 (2009), *order on reh’g*, Order No. 697-D, FERC Stats. & Regs. ¶ 31,305 (2010).

² Order No. 697 at P 186.

³ Order No. 697 at P 187.

Concurring Statement

On behalf of [Company Name], I am authorized to countersign this letter in concurrence with its content.

By: _____

[Name]

[Company Position]

[Company Name]

APPENDIX XVIII

SUPPLIER DIVERSITY PROGRAM

1. Women-, Minority-, and service Disabled Veteran-owned Business Enterprises, as verified pursuant to the procedures prescribed in Section 2 of CPUC General Order 156 (“WMDVBE”), shall have the maximum practicable opportunity to participate in the performance of work supporting Seller’s development of the Project.
2. Upon request from Buyer, Seller shall provide a separate “Supplier Plan” consisting of a specific list of suppliers that may participate in the performance of the work supporting development of the Project, and a statement setting forth any additional efforts Seller will employ to increase the participation of WMDVBE suppliers supporting development of the Project.
3. Upon request from Buyer, but no less than once per 365 day period of time between the execution of the PPA and the Commercial Operation Date, Seller shall report its spend with WMDVBE owned suppliers using PG&E’s electronic reporting system located at: <https://www.pgesupplierdiversity.com/pge/login.asp>. To establish a user ID, Seller shall submit a request via email to the following address: supplierdiversityteam@pge.com.
4. Seller’s supplier diversity spend target for work supporting the Project is five percent (5%) of the value of the EPC Contract for the Project.
5. Seller agrees that the obligations established through this Appendix XVIII are material obligations.

APPENDIX XIX

ENXCO QF AGREEMENTS

“enXco QF Agreements” means the collective of the following agreements:

- (a) Standard Offer #4 Power Purchase Agreement for Long-Term Energy and Capacity relating to a 100,000 kW Facility, by and between U.S. Windpower, Inc. and Pacific Gas and Electric Company, signed by U.S. Windpower, Inc. on October 30, 1984 and signed by PG&E on November 5, 1984, as amended (PG&E Log No. 01W146C);
- (b) Standard Offer #4 Power Purchase Agreement for Long-Term Energy and Capacity relating to a 70,000 kW Facility, by and between U.S. Windpower, Inc. and Pacific Gas and Electric Company, signed by PG&E on March 2, 1984 and signed by U.S. Windpower, Inc. on March 5, 1984, as amended, (PG&E Log No. 06W146C);
- (c) Standard Offer #4 Power Purchase Agreement for Long-Term Energy and Capacity relating to a 10,000 kW Facility, by and between U.S. Windpower, Inc. and Pacific Gas and Electric Company, signed by U.S. Windpower, Inc. on October 30, 1984 and signed by PG&E on November 5, 1984, as amended, (PG&E Log No. 06W148).

APPENDIX XX

FORM OF CONTRACT CAPACITY NOTICE

In accordance with Section 3.9(c)(iv)(C) of the Agreement, if Seller has elected to reduce the Contract Capacity, then Seller must provide this notice to Buyer at least five (5) Business Days prior to the Commercial Operation Date.

- 1) The revised Contract Capacity is _____, which amount shall not be less than 90 MW.

- 2) The Contract Quantity shall be reduced as indicated in the table below, which shall reflect a pro rata reduction based on the Contract Capacity set forth above and applied to the quantities set forth in Appendix V of this Agreement.

Contract Year	Contract Quantity
Years 1-20	
Year 21	
Year 22	
Year 23	
Year 24	
Year 25	

- 3) The Delivery Term Security as set forth in Section 8.4(a)(iii) shall be reduced to _____ dollars (\$_____.00), which shall reflect a pro rata reduction based on the Contract Capacity set forth above.