

SOUTHERN CALIFORNIA
EDISON

An *EDISON INTERNATIONAL* Company

GENERATING FACILITY POWER PURCHASE AND SALE AGREEMENT

between

SOUTHERN CALIFORNIA EDISON COMPANY

and

ALTA WIND VI, LLC

(RAP ID #6319)

TABLE OF CONTENTS

	Page
ARTICLE ONE. GENERATING FACILITY INFORMATION.....	3
1.01 Generating Facility.....	3
1.02 Energy Price.....	3
1.03 Expected Initial Operation Date.....	5
1.04 Firm Operation Date	5
1.05 Facility Term.....	5
1.06 Performance Assurance Amount	6
1.07 Seller’s Guarantor	6
1.08 Seller’s Debt to Equity Ratio	6
1.09 ISO Change Cost Threshold Amount	6
ARTICLE TWO. FACILITY TERM AND CONDITIONS PRECEDENT; TERMINATION.....	8
2.01 Power Purchase Agreement Effective Date and Facility Term	8
2.02 Obligations Prior to Commencement of Facility Term	8
2.03 Conditions Precedent to Commencement of Facility Term.....	9
2.04 Termination Rights of the Parties	11
2.05 Rights and Obligations Surviving Termination	13
ARTICLE THREE. SELLER’S OBLIGATIONS	19
3.01 Conveyance of Entire Output, Conveyance of Green Attributes and Capacity Attributes	19
3.02 Resource Adequacy Benefits	20
3.03 Seller’s Obligations to Deliver.....	21
3.04 Demonstration of Nameplate Contract Capacity	22
3.05 Production and Availability Requirements	23
3.06 Metering.....	25
3.07 Site Control	27

The contents of this document are subject to restrictions on disclosure as set forth herein.

TABLE OF CONTENTS
(Continued)

	Page
3.08 Site Location	27
3.09 Design	27
3.10 Operation.....	28
3.11 Progress Reporting.....	30
3.12 No Representation by SCE	30
3.13 Provision of Information.....	31
3.14 SCE’s Access Rights.....	31
3.15 Reserved.....	31
3.16 Obtaining and Maintaining CEC Certification and Verification	31
3.17 Notice of Cessation or Termination of Service Agreements	32
3.18 Report of Lost Output	32
3.19 Scheduling and Related Obligations.....	33
ARTICLE FOUR. SCE’S OBLIGATIONS.....	39
4.01 Obligation to Pay	39
4.02 Payments and Adjustments.....	39
4.03 Payment Statement and Payment.....	41
4.04 Cooperation with Seller and Scheduling.....	44
4.05 SCE as Scheduling Coordinator.....	44
4.06 Interest Payments on Cash Deposits.....	46
ARTICLE FIVE. FORCE MAJEURE	47
5.01 No Default for Force Majeure.....	47
5.02 Requirements Applicable to the Claiming Party	47
5.03 Expected Initial Operation Date or Expected Construction Commencement Date Extension.....	48

The contents of this document are subject to restrictions on disclosure as set forth herein.

TABLE OF CONTENTS
(Continued)

	Page
5.04 Firm Operation Date Extension	48
5.05 Termination.....	48
ARTICLE SIX. EVENTS OF DEFAULT: REMEDIES.....	49
6.01 Events of Default	49
6.02 Early Termination	53
6.03 Termination Payment.....	53
ARTICLE SEVEN. LIMITATIONS OF LIABILITIES.....	55
ARTICLE EIGHT. CREDIT AND COLLATERAL REQUIREMENTS	57
8.01 Financial Information.....	57
8.02 Performance Assurance	57
8.03 First Priority Security Interest in Cash or Cash Equivalent Collateral	60
8.04 Subordinated Security Interests and Mortgage.....	60
8.05 Credit and Collateral Covenants	63
8.06 Waivers	64
ARTICLE NINE. GOVERNMENTAL CHARGES.....	65
9.01 Cooperation to Minimize Tax Liabilities.....	65
9.02 Governmental Charges.....	65
9.03 Providing Information to Taxing Authorities	65
ARTICLE TEN. MISCELLANEOUS	66
10.01 Representations, Warranties and Covenants.....	66
10.02 Additional Representations, Warranties and Covenants.....	67
10.03 Indemnity	67
10.04 Assignment	68
10.05 Consent to Collateral Assignment	68

The contents of this document are subject to restrictions on disclosure as set forth herein.

TABLE OF CONTENTS
(Continued)

	Page
10.06 Abandonment.....	71
10.07 Governing Law	72
10.08 Notices	72
10.09 General.....	72
10.10 Confidentiality	74
10.11 Insurance.....	77
10.12 Nondedication.....	78
10.13 Mobile Sierra	78
10.14 Simple Interest Payments.....	78
10.15 Payments.....	78
10.16 Injunctive Relief.....	78
10.17 Further Actions	79
ARTICLE ELEVEN. CHANGE IN ELECTRIC MARKET DESIGN	80
11.01 Changes Rendering the Agreement Incapable of Performance	80
11.02 Changes Resulting in Costs or Benefits to Seller	80
11.03 Procedure for Claiming an ISO Change Cost Payment.....	82
11.04 SCE’s Mitigation Rights	83
ARTICLE TWELVE. MEDIATION AND ARBITRATION	86
12.01 Dispute Resolution.....	86
12.02 Mediation	86
12.03 Arbitration.....	86
12.04 Waivers	88

The contents of this document are subject to restrictions on disclosure as set forth herein.

LIST OF EXHIBITS

- A. Definitions.
- B. Final Notice to Proceed.
- C. Notice List.
- D. Scheduling Requirements and Procedures Applicable When SCE is Not Seller's Scheduling Coordinator.
- E. Payment Adjustments for Scheduling Deviations By Seller.
- F. Seller's Annual Shortfall Payment.
- G. Seller's Milestone Schedule.
- H. Milestone Progress Reporting Form.
- I. Form of Guaranty Agreement.
- J. Notice of Right of First Offer.
- K. Time of Delivery Periods and Energy Payment Allocation Factors.
- L. Benchmark Bid Prices.
- M. Seller's Estimate of Lost Output.
- N. Form of Letter of Credit.
- O. Seller's Long Term Availability Shortfall Payment.
- P. ISO Change Cost Payment Calculation.
- Q. Forecasting and Scheduling Requirements and Procedures Applicable When SCE is Seller's Scheduling Coordinator.
- R. SCE Penalties and ISO Sanctions.
- S. Actual Availability Report.
- T. Form of Subordinated Leasehold Deed of Trust, Security Agreement, Assignment of Rents and Leases and Fixture Filing.
- U. Form of Intercreditor and Subordination Agreement.

The contents of this document are subject to restrictions on disclosure as set forth herein.

GENERATING FACILITY POWER PURCHASE AND SALE AGREEMENT

between

SOUTHERN CALIFORNIA EDISON COMPANY

and

ALTA WIND VI, LLC

(RAP ID #6319)

This Generating Facility Power Purchase and Sale Agreement, together with the exhibits, attachments, and any referenced collateral agreement or similar arrangement between the Parties (collectively, the "Power Purchase Agreement") is made and effective as of the following date: February 23, 2010 ("Power Purchase Agreement Effective Date").

This Power Purchase Agreement is entered into between:

- (i) **Southern California Edison Company** ("SCE"), a California corporation, whose principal place of business is at 2244 Walnut Grove Avenue, Rosemead, California 91770, and
- (ii) **Alta Wind VI, LLC** ("Seller"), a Delaware limited liability company, whose principal place of business is at 11452 El Camino Real, Suite 215; San Diego, CA 92130.

SCE and Seller are sometimes referred to herein individually as a "Party" and jointly as "Parties."

Seller is a special purpose entity formed by Alta Windpower Development, LLC ("Developer"), in connection with that certain Master Power Purchase and Wind Project Development Agreement between SCE and Developer made and effective as of December 21, 2006 (the "Master Agreement") and is an "SPE" referred to in the Master Agreement.

Seller is willing (i) to construct, own, and Operate an electric energy Generating Facility which would qualify, as of the Master Agreement Effective Date, as an eligible renewable energy resource under the State of California Renewables Portfolio Standard Program as codified at California Public Utilities Code Section 399.11, *et seq.*, and (ii) to sell all net electric energy produced by the Generating Facility as specified herein together with all Green Attributes, Capacity Attributes and Resource Adequacy Benefits to SCE; and

The contents of this document are subject to restrictions on disclosure as set forth herein.

SCE is willing to purchase all electric energy delivered by Seller to SCE generated by such Generating Facility under this Power Purchase Agreement together with all Green Attributes, Capacity Attributes and Resource Adequacy Benefits pursuant to the terms and conditions set forth herein.

Capitalized terms in this Power Purchase Agreement shall have the meanings set forth in Exhibit A.

ARTICLE ONE. GENERATING FACILITY INFORMATION

1.01 Generating Facility.

- (a) Name: The Generating Facility Name as provided in Section 2(a) of the Final Notice to Proceed for the Generating Facility, attached hereto as Exhibit B.
- (b) Location of Site: The Location of Site as provided in Section 2(b) and Exhibit 1 of the Final Notice to Proceed for the Generating Facility, attached hereto as Exhibit B.
- (c) Eligible Renewable Energy Resource Type: Wind.
- (d) Nameplate Contract Capacity: The Nameplate Contract Capacity as provided in Section 2(c) of the Final Notice to Proceed for the Generating Facility, attached hereto as Exhibit B.
The Nameplate Contract Capacity may be reduced as set forth in Sections 3.04(d) and 3.04(e).

1.02 Energy Price.

- (a) Except as provided in Section 1.02(b) or Section 1.02(c), the Energy Price shall be equal to the Final Energy Price as provided in Section 3(e) of the Final Notice to Proceed for the Generating Facility, attached hereto as Exhibit B.
- (b) If the Initial Operation Date of the Generating Facility is in an earlier calendar year than the calendar year of the Expected Initial Operation Date as provided in Section 2(d) of the Final Notice to Proceed for the Generating Facility, attached hereto as Exhibit B, SCE and Seller shall amend the Energy Price in this Power Purchase Agreement. The amended Energy Price shall be calculated based upon the Benchmark Bid Price set forth in Table A of Exhibit L for the calendar year in which the Initial Operation Date of the Generating Facility occurs, and such Benchmark Bid Price shall then be multiplied by the Energy Price Adjustment as provided in Section 3(d) of the Final Notice to Proceed for the Generating Facility, attached hereto as Exhibit B, subject to Sections 1.02(d) and 1.02(e).
- (c) If the Initial Operation Date of the Generating Facility is in a later calendar year than the calendar year of the Expected Initial Operation Date as provided in Section 2(d) of the Final Notice to Proceed for the Generating Facility, attached hereto as Exhibit B, because:
 - (i) a Force Majeure delays the Initial Operation Date, subject to Seller's compliance with its obligations as the Claiming Party under Section 5.02; or

(ii) the interconnection and transmission facilities for the Generating Facility, as described in the Generating Facility's Large Generator Interconnection Agreement (or if such agreement is not in place, then the most reliable option in its final Facility Study, and if such study is not complete, then the most reliable option in its final System Impact Study), were not tested and placed in service, other than due to the fault or gross negligence of Seller or Developer (but only to the extent that Developer is responsible for, or is, pursuing such interconnection or transmission facilities for the benefit of Seller), by the Expected Initial Operation Date;

then SCE and Seller shall amend the Energy Price in this Power Purchase Agreement.

The amended Energy Price shall be calculated based upon the Benchmark Bid Price set forth in Table A of Exhibit L for the calendar year in which the Initial Operation Date of the Generating Facility occurs, and such Benchmark Bid Price shall then be multiplied by the Energy Price Adjustment as provided in Section 3(d) of the Final Notice to Proceed for the Generating Facility, attached hereto as Exhibit B, subject to Sections 1.02(d) and 1.02(e).

(d) If the amended Energy Price determined under Section 1.02(b) or Section 1.02(c) would exceed the Energy Price Maximum as set forth in Exhibit B for the calendar year in which the Initial Operation Date of the Generating Facility occurs, and Section 3(e) of the Final Notice to Proceed for the Generating Facility, attached hereto as Exhibit B, contains a Final Energy Price:

(i) that exceeds the Energy Price Maximum as set forth in Exhibit B for the calendar year of the Expected Initial Operation Date of the Generating Facility, then the Energy Price in this Power Purchase Agreement shall be amended pursuant to Section 1.02(b) or Section 1.02(c) (as applicable) without regard to whether to the Energy Price, as so amended, would otherwise exceed the Energy Price Maximum as set forth in Exhibit B for the calendar year in which the Initial Operation Date of the Generating Facility occurs; or

(ii) that is equal to or less than the Energy Price Maximum as set forth in Exhibit B for the calendar year of the Expected Initial Operation Date of the Generating Facility, then the Energy Price in this Power Purchase Agreement shall be amended pursuant to Section 1.02(b) or Section 1.02(c) (as applicable) to an amount equal to the Energy Price Maximum as set forth in Exhibit B for the calendar year in which the Initial Operation Date of the Generating Facility occurs.

-
-
- (e) If the amended Energy Price determined under Section 1.02(b) or Section 1.02(c) would be less than the Energy Price Minimum as set forth in Exhibit B for the calendar year in which the Initial Operation Date of the Generating Facility occurs, and Section 3(e) of the Final Notice to Proceed for the Generating Facility, attached hereto as Exhibit B, contains a Final Energy Price:
- (i) that is less than the Energy Price Minimum as set forth in Exhibit B for the calendar year of the Expected Initial Operation Date of the Generating Facility, then the Energy Price in this Power Purchase Agreement shall be amended pursuant to Section 1.02(b) or Section 1.02(c) (as applicable) without regard to whether to the Energy Price, as so amended, would otherwise be less than the Energy Price Minimum as set forth in Exhibit B for the calendar year in which the Initial Operation Date of the Generating Facility occurs; or
 - (ii) that is equal to or more than the Energy Price Minimum as set forth in Exhibit B for the calendar year of the Expected Initial Operation Date of the Generating Facility, then the Energy Price in this Power Purchase Agreement shall be amended pursuant to Section 1.02(b) or Section 1.02(c) (as applicable) to an amount equal to the Energy Price Minimum as set forth in Exhibit B for the calendar year in which the Initial Operation Date of the Generating Facility occurs.

1.03 Expected Initial Operation Date.

The Expected Initial Operation Date shall be the Expected Initial Operation Date as provided in Section 2(d) of the Final Notice to Proceed for the Generating Facility, attached hereto as Exhibit B, as it may be extended pursuant to the terms of this Power Purchase Agreement.

1.04 Firm Operation Date.

The Firm Operation Date shall be the date that is six (6) months after the Initial Operation Date, plus any additional days for Force Majeure as provided in Section 5.04, or as may be agreed to in a writing signed by both Parties.

1.05 Facility Term.

The Facility Term shall commence as set forth in Section 2.03(a) and shall end on the date that is the later of (a) the last day of the calendar month which is two hundred and forty (240) months from the month of the Firm Operation Date, and (b) December, 31, 2035.

The contents of this document are subject to restrictions on disclosure as set forth herein.

1.06 Performance Assurance Amount.

Eighty seven thousand five hundred dollars (\$87,500) per MW of Nameplate Contract Capacity.

1.07 Seller's Guarantor.

- (a) Guarantor: A Person that may from time-to-time become a party to a Guaranty Agreement in accordance with Sections 8.02(a) and 8.02(c).
- (b) Cross Default Amount: To be supplied if there is a Guarantor in accordance with Section 8.02(a).

1.08 Seller's Debt to Equity Ratio.

In connection with the first Permanent Financing, and in connection with any subsequent Senior Loan, on the date on which any Senior Lender first advances funds under its Senior Loan (not including any date on which a Tax Equity Provider advances funds used to pay another Senior Lender), Seller's Debt to Equity Ratio shall not exceed nine (9).

1.09 ISO Change Cost Threshold Amount.

The ISO Change Cost Threshold Amount for each Facility Term Year shall be the value calculated in accordance with the following formula:

$$\text{ISO CHANGE COST THRESHOLD AMOUNT} = A \times B \times C$$

Where A = Estimated Annual Production in kWh (i.e., MWh/1000).

-
- B = Generation-weighted average of the time-differentiated Energy Price (i.e., generation-weighted average of “D” x “E” below) based on Metered Amounts for all Settlement Intervals in the Facility Term Year in \$/kWh (i.e., (\$/MWh)/1000).
- C = Two percent (2%).
- D = Energy Price in \$/kWh (i.e., (\$/MWh)/1000).
- E = Energy Payment Allocation Factor, set forth in Exhibit K, applicable to the Settlement Interval being calculated.

**** End of ARTICLE ONE ****

**ARTICLE TWO. FACILITY TERM AND CONDITIONS PRECEDENT;
TERMINATION**

2.01 Power Purchase Agreement Effective Date and Facility Term.

This Power Purchase Agreement shall become effective on the Power Purchase Agreement Effective Date, although, as described herein, many of the rights and responsibilities of the Parties commence with the beginning of the Facility Term.

2.02 Obligations Prior to Commencement of the Facility Term.**(a) Seller's Interconnection Application.**

Seller shall exercise diligence in obtaining a FERC-accepted interconnection agreement and any transmission, distribution or other service agreement required to transmit electric energy from the Generating Facility to the Delivery Point.

Seller represents that, as of the Power Purchase Agreement Effective Date, it does not possess interconnection or transmission rights.

(b) Seller's Regulatory and Governmental Filings.

(i) On or before the date that is six (6) months prior to the Expected Initial Operation Date, Seller shall file or cause to be filed on its behalf:

(1) An application or other appropriate request with the CEC for CEC Certification and Verification for the Generating Facility (*provided that* Seller shall not be required to file or cause to be filed such application or request if the Generating Facility is ineligible for CEC Certification and Verification as a result of a change in the RPS Legislation, or the rules or regulations relating thereto, after the Master Agreement Effective Date, and Seller is unable to make such Generating Facility eligible through commercially reasonable efforts (which efforts to make the Generating Facility eligible shall not require Seller to incur out of pocket costs in excess of \$25,000 in any year with respect to the Generating Facility in order to obtain CEC Certification and Verification)); and

(2) All applications or other appropriate requests with the proper authorities for all other Permits that can be obtained at that stage of the development process.

(ii) After filing its applications or other appropriate requests as provided in Sections 2.02(b)(i)(1) and 2.02(b)(i)(2) above, Seller shall

The contents of this document are subject to restrictions on disclosure as set forth herein.

expeditiously seek CEC Certification and Verification (subject to Section 2.02(b)(i)(1)) and all Permits, including, among other things, promptly responding to any requests for information from the requesting authority.

(c) Seller's Application for Participation in the Participating Intermittent Resource Program ("PIRP").

No later than ninety (90) days before the Expected Initial Operation Date, or as may be agreed to in a writing signed by both Parties, Seller shall submit in accordance with applicable tariffs and regulations an application or other request for participation and certification in the PIRP or any successor program to the PIRP, and shall thereafter exercise diligence and expeditiously proceed with the application process.

2.03 Conditions Precedent to Commencement of Facility Term.

(a) Commencement of Facility Term.

The Facility Term shall commence on the Initial Operation Date.

(b) Initial Operation and Initial Operation Date.

(i) Initial operation of the Generating Facility ("Initial Operation") shall be deemed to have been achieved on the date selected by Seller (the "Initial Operation Date"):

- (1) To begin Scheduling and delivering Product to SCE, if SCE is not acting as Seller's Scheduling Coordinator; or
- (2) To begin Forecasting and delivering Product to SCE, if SCE is acting as Seller's Scheduling Coordinator.

(ii) Seller shall provide at least three (3) Business Days advance Notice to SCE of the Initial Operation Date.

(iii) The Initial Operation Date shall be no later than the last to occur of the following:

- (1) Sixty (60) days from the first date that the Generating Facility operates in parallel with the applicable Transmission Provider's electric system, if Seller does not participate in PIRP;
- (2) One hundred twenty (120) days from the first date that the Generating Facility operates in parallel with the applicable

The contents of this document are subject to restrictions on disclosure as set forth herein.

Transmission Provider's electric system, if Seller participates in PIRP; or

- (3) Five (5) days from the date that Seller becomes a Participating Intermittent Resource, if Seller participates in PIRP.
- (iv) In addition, on or prior to the Initial Operation Date:
- (1) The Generating Facility shall be Operating in parallel with the applicable Transmission Provider's electric system;
 - (2) If SCE is not acting as Seller's Scheduling Coordinator, Seller shall be Scheduling electric energy from the Generating Facility to SCE at the Delivery Point;
 - (3) If SCE is acting as Seller's Scheduling Coordinator, Seller shall be Forecasting and delivering electric energy from the Generating Facility to SCE at the Delivery Point;
 - (4) Seller shall have demonstrated to SCE's reasonable satisfaction that Seller has executed all necessary Transmission Provider and Scheduling Coordinator agreements and Required ISO Agreements;
 - (5) Seller shall have obtained CEC Certification and Verification; *provided that*, such CEC Certification and Verification shall not be required to the extent that Seller is unable to obtain CEC Certification and Verification because of a change in the RPS Legislation, or the rules or regulations relating thereto, occurring after the Master Agreement Effective Date; *provided further that*:
 - (A) The Generating Facility would have qualified for CEC Certification and Verification under the RPS Legislation, and the rules and regulations relating thereto, as of the Master Agreement Effective Date; and
 - (B) Seller has made commercially reasonable efforts to obtain CEC Certification and Verification under the then current Applicable Law. Seller shall not be required to incur out of pocket costs in excess of \$25,000 in any year in order to obtain CEC Certification and Verification under the then current Applicable Law;
 - (6) Seller shall have obtained all Material Permits;

The contents of this document are subject to restrictions on disclosure as set forth herein.

- (7) Seller shall be in compliance with its obligations as set forth in Section 3.06(a) and shall have secured all Required ISO Agreements;
- (8) Seller shall have posted with SCE the Performance Assurance required under Section 8.02;
- (9) SCE and Seller shall have executed all Security Documents required by Section 8.04;
- (10) Seller shall have furnished to SCE the insurance documents required under Section 10.11(b); and
- (11) If SCE is acting as Seller's Scheduling Coordinator, SCE shall have been authorized by the ISO to Schedule the electric energy produced by the Generating Facility with the ISO.

2.04 Termination Rights of the Parties.

(a) Termination Rights of Seller.

- (i) Seller shall have the right to terminate this Power Purchase Agreement, without liability of any kind to SCE under this Power Purchase Agreement (subject to Section 2.05), on Notice, which shall be effective five (5) Business Days after such Notice is given to SCE, if a Material Permit for the Generating Facility which in the normal course would have been obtained by the Expected Construction Commencement Date (as the same may have been extended) has not been obtained by that date due to circumstances that were outside the reasonable control of Seller or Developer (but only to the extent that Developer is responsible for, or is, pursuing such Material Permit for the benefit of Seller) and so long as Seller or Developer (but only to the extent that Developer is responsible for, or is, pursuing such Material Permit for the benefit of Seller) has diligently pursued such Material Permit, and such Notice is given to SCE not later than ninety (90) days after the Expected Construction Commencement Date, or such later date as may be agreed to in a writing signed by both Parties.
- (ii) Seller shall have the right to terminate this Power Purchase Agreement, without liability of any kind to SCE under this Power Purchase Agreement (subject to Section 2.05), on Notice, which shall be effective five (5) Business Days after such Notice is given to SCE, if Federal Production Tax Credit Legislation is not enacted on or before January 1 of the year of the Expected Initial Operation Date, or such later date as may be agreed to in a writing signed by both Parties, and such Notice is given to SCE not later than March 31 of the year of

The contents of this document are subject to restrictions on disclosure as set forth herein.

the Expected Initial Operation Date, or such later date as may be agreed to in a writing signed by both Parties.

(iii) Seller shall have the right to terminate this Power Purchase Agreement, without liability of any kind to SCE under this Power Purchase Agreement (subject to Section 2.05), on Notice, which shall be effective five (5) Business Days after such Notice is given to SCE, if and when the Large Generator Interconnection Agreement for the Generating Facility requires Seller to expend funds for LGIA Upgrades consistent with the schedule provided for in the Large Generator Interconnection Agreement (not including any delay of the schedule associated with suspensions).

(iv) Seller shall have the right to terminate this Power Purchase Agreement, without liability of any kind to SCE under this Power Purchase Agreement (subject to Section 2.05), on Notice, which shall be effective five (5) Business Days after such Notice is given, if the interconnection and transmission facilities for the Generating Facility, as described in the Generating Facility's Large Generator Interconnection Agreement (or if such agreement is not in place, then the most reliable option in its final Facility Study, and if such study is not complete, then the most reliable option in its final System Impact Study), are not tested and placed in service, other than due to the fault or gross negligence of Seller or Developer (but only to the extent that Developer is responsible for, or is, pursuing such interconnection or transmission facilities for the benefit of Seller), within three hundred sixty-five (365) days after the Expected Initial Operation Date; *provided that*, such Notice must be provided no more than thirty (30) days after the end of such three hundred sixty-five (365) day period.

(b) Uncured Defaults.

If an Event of Default has occurred and is continuing as of the date the Non-Defaulting Party designates, by Notice, an Early Termination Date pursuant to Section 6.02(a), the Non-Defaulting Party may terminate this Power Purchase Agreement as set forth in Section 6.02.

(c) End of Facility Term.

At the end of the Facility Term as set forth in Section 1.05, this Power Purchase Agreement shall automatically terminate, unless the Parties mutually agree to extend this Power Purchase Agreement.

(d) Termination Rights of SCE.

SCE shall have the right to terminate this Power Purchase Agreement, without liability of any kind to Seller under this Power Purchase Agreement (subject to Section 2.05), on Notice, which shall be effective five (5) Business Days after such Notice is given to Seller, if Seller does not achieve the Initial Operation Date within four (4) years of the Power Purchase Agreement Effective Date; *provided that* such four (4) year deadline shall be extended, day-for-day, to account for any delays in Seller achieving the Initial Operation Date due to Force Majeure, subject to Seller's compliance with its obligations as the Claiming Party under Section 5.02, and to account for any delays in Seller achieving the Initial Operation Date due to the interconnection and transmission facilities for the Generating Facility, as described in the Generating Facility's Large Generator Interconnection Agreement (or if such agreement is not in place, then the most reliable option in its final Facility Study, and if such study is not complete, then the most reliable option in its final System Impact Study), not becoming tested and placed in service, other than due to the fault or gross negligence of Seller or Developer (but only to the extent that Developer is responsible for, or is, pursuing such interconnection or transmission facilities for the benefit of Seller), by the Expected Initial Operation Date; *provided further that*, in no event shall such four (4) year deadline be extended for more than three hundred sixty-five (365) days.

2.05 Rights and Obligations Surviving Termination.

(a) Survival of Rights and Obligations Generally.

The rights and obligations that are intended to survive a termination of this Power Purchase Agreement are all of those rights and obligations that this Power Purchase Agreement expressly provides shall survive any such termination and those that arise from Seller's or SCE's covenants, agreements, representations, and warranties applicable to, or to be performed, at or during any time prior to or as a result of the termination of this Power Purchase Agreement, including, without limitation:

- (i) Seller's obligation to pay Seller's Annual Shortfall Payments or Seller's Long Term Availability Shortfall Payments under Section 3.05, in each case accrued as of end of the Facility Term and not taken into account in calculating the Termination Payment;
- (ii) The obligation to make a Termination Payment under Section 6.03;
- (iii) The indemnity obligations to the extent provided in Section 10.03;
- (iv) The obligation of confidentiality set forth in Section 10.10;

The contents of this document are subject to restrictions on disclosure as set forth herein.

- (v) The right to pursue remedies under Section 6.02;
- (vi) The right to receive a Termination Payment under Section 6.03;
- (vii) The limitation of damages under Article Seven;
- (viii) The obligation of SCE to make Energy Payments for energy Scheduled and delivered to SCE prior to termination under Section 4.02, if SCE is not acting as Seller's Scheduling Coordinator;
- (ix) The obligation of SCE to make Energy Payments for energy delivered to SCE prior to termination under Section 4.02, if SCE is acting as Seller's Scheduling Coordinator;
- (x) The obligation of Seller to make payments for ISO Charges, ISO Sanctions and any SCE Penalties that are attributable to Seller's actions or omissions during the Facility Term pursuant to Section 3.19(b) and Exhibit R, if SCE is acting as Seller's Scheduling Coordinator;
- (xi) The covenants and indemnifications regarding the limitations on Seller's, Seller's Affiliates or any transferee's ability to offer, make or agree to third party sales as set forth in Sections 2.05(b) and 3.04(f);
- (xii) The obligation of Seller to maintain Performance Assurance posted under Section 8.02;
- (xiii) SCE's rights and Seller's obligations with respect to the Secured Interests under Section 8.04;
- (xiv) The obligation to make payment adjustments under this Power Purchase Agreement;
- (xv) The right to specific performance and injunctive or other equitable relief under Section 10.16 in connection with an obligation that, in itself, survives termination;
- (xvi) The dispute resolution provisions of Article Twelve; and
- (xvii) Seller's obligations under Section 3.07 and Section 10.06 for so long as SCE's Right of First Offer pursuant to Section 2.05(b) is in effect.

(b) Limitations on Seller's Ability to Make or Agree to Third Party Sales from the Generating Facility after Certain Terminations of the Power Purchase Agreement.

- (i) If this Power Purchase Agreement is terminated after the Initial Operation Date pursuant to Section 5.05 for Force Majeure as to which Seller is the Claiming Party, then:
- (1) Upon the effective date of such termination, Seller shall deliver a Notice of Right of First Offer in respect of the Site, in the form attached hereto as Exhibit J that SCE may record in the Official Records giving notice of SCE's rights under this Section 2.05(b);
 - (2) None of Seller or Seller's Affiliates may sell, or enter into an agreement to sell, electric energy, Green Attributes, Capacity Attributes or Resource Adequacy Benefits associated with or attributable to the Generating Facility or any wind-powered generating facility located on the Site ("Resource Sale") to a party other than SCE for a period of three (3) years following the effective date of such termination, subject to subsections (ii) through (x) below; and
 - (3) Seller shall indemnify and hold SCE harmless from all benefits lost and other damages sustained by SCE as a result of any breach by Seller or an Affiliate of Seller of the covenant contained within this Section 2.05(b) prohibiting a Resource Sale.
- (ii) The prohibition on contracting and sale in Section 2.05(b)(i) shall not apply if within twelve (12) months after Seller or its Affiliate provides SCE with a written offer to sell to SCE the electric energy, Green Attributes, Capacity Attributes or Resource Adequacy Benefits associated with or attributable to the Generating Facility or Site, which offer contains the Material Terms of such sale, and SCE fails to accept in writing such offer within thirty (30) days of SCE's receipt thereof, Seller or its Affiliate enters into a contract with a third party with respect to a Resource Sale on Material Terms that are not Materially More Favorable Terms than the Material Terms offered to SCE in the written offer. If Seller enters into a contract with a third party pursuant to this Section 2.05(b) for less than all of the electric energy, Green Attributes, Capacity Attributes and Resource Adequacy Benefits associated with or attributable to the Generating Facility or Site, then the Right of First Offer shall continue to apply for the remaining products. Seller or its Affiliate may provide only one new written offer to SCE in each ninety (90) day period, except such limitation

The contents of this document are subject to restrictions on disclosure as set forth herein.

shall not apply if Seller or its Affiliate is in active negotiations with a third party and presents an offer to SCE in connection therewith.

- (iii) If, at any time, Seller or its Affiliate proposes to enter into a definitive agreement with such third party with respect to a Resource Sale, Seller shall provide Notice to SCE, along with a draft of such agreement (which draft will be considered Confidential Information), which Notice shall state whether Seller believes that the draft agreement contains Material Terms that are Materially More Favorable Terms than those offered to SCE and identifying the Material Terms of the draft agreement.
- (iv) Within thirty (30) days of its receipt of such Notice and draft agreement, SCE shall, by written Notice, (1) state whether it believes that the draft agreement contains Material Terms that are Materially More Favorable Terms than those offered to SCE, (2) provide an explanation as to the basis for its belief that the draft agreement contains Material Terms that are Materially More Favorable Terms, if applicable, and (3) state whether it is willing to enter into this Power Purchase Agreement with Seller or its Affiliate on the same terms as the Material Terms of the draft agreement.
- (v) If SCE (1) fails to respond within such thirty (30) days, (2) responds timely that the draft agreement does not contain Materially More Favorable Terms than those offered to SCE, or (3) responds timely that the draft agreement contains Materially More Favorable Terms than those offered to SCE and states that SCE is not willing to enter into this Power Purchase Agreement with Seller or its Affiliate on the same terms as the Material Terms, then Seller or its Affiliate shall be free to enter into a definitive agreement with the third party on the same Material Terms as those provided to SCE in the draft agreement.
- (vi) If SCE responds timely and states its belief that the draft agreement contains Material Terms that are Materially More Favorable Terms than those offered to SCE and states that SCE is willing to enter into the Power Purchase Agreement with Seller or its Affiliate on the same terms as the Material Terms as set forth in the draft agreement, Seller may, within five (5) Business Days, either accept SCE's offer, in which case, subject to CPUC approval, if required as determined by SCE in its sole discretion, the Parties shall enter into a contract in the form of this Power Purchase Agreement, modified only to the extent necessary to reflect the Material Terms in the draft agreement, within thirty (30) Business Days, or, if Seller disputes that the draft agreement contains Material Terms that are Materially More Favorable Terms than those offered to SCE, then submit the matter to arbitration under Section 12.03 without first having to go through mediation

The contents of this document are subject to restrictions on disclosure as set forth herein.

under Section 12.02. If Seller fails to submit the matter to arbitration, it shall be deemed to have accepted SCE's offer. If SCE seeks CPUC approval, then SCE shall seek such approval expeditiously, including promptly responding to any requests for information related to the request for approval from the CPUC, and if a decision approving such contract is not obtained within six (6) months after the Parties have entered into such contract, SCE may waive such CPUC approval condition or, if not so waived, Seller may terminate such contract and enter into a contract with a third party containing the same Material Terms.

- (vii) Notwithstanding anything to the contrary in Section 12.03(f), if Seller has submitted the matter to arbitration, the Arbitrator shall allocate against the Party who did not prevail the prevailing Party's reasonable attorneys' fees and expenses related to the prevailing Party's participation in the Arbitration, and if the Arbitrator determines that the non-prevailing Party's position related to the dispute was asserted in bad faith, the Arbitrator may award to the prevailing Party an additional penalty in an amount as determined by the Arbitrator in his or her discretion.
- (viii) The Parties acknowledge and agree that, for purposes of this Section 2.05(b), "Material Terms" mean energy price, product (*i.e.*, electric energy, associated environmental attributes, capacity attributes, resource adequacy benefits or other attributes arising from the generating facility and offered for sale under the applicable contract), duration, financial terms, credit support, energy delivery guaranties and availability warranties, and "Materially More Favorable Terms" means only:
- (1) a lower energy price and other financial terms, considering the duration and product, that, in the aggregate, are materially more favorable to the third party purchaser;
 - (B) credit support in materially higher amounts or in materially superior quality than that offered to SCE;
 - (C) energy delivery guaranties that are materially more favorable to the third party purchaser; or
 - (D) availability warranties that are materially more favorable to the third party purchaser.
- (ix) In the event that Seller or its Affiliate has entered into a definitive agreement with a third party with respect to a Resource Sale in compliance with this Section 2.05(b), then, within thirty (30) days of

The contents of this document are subject to restrictions on disclosure as set forth herein.

Notice of such definitive agreement, SCE shall release and terminate of record any Notice of Right of First Offer recorded against the Site.

- (x) The Right of First Offer pursuant to this Section 2.05(b) shall expire three (3) years following the effective date of any termination after the Initial Operation Date pursuant to Section 5.05 for Force Majeure as to which Seller is the Claiming Party.

**** End of ARTICLE TWO ****

ARTICLE THREE. SELLER'S OBLIGATIONS**3.01 Conveyance of Entire Output, Conveyance of Green Attributes and Capacity Attributes.**

- (a) If SCE is not acting as Seller's Scheduling Coordinator, Seller shall use best efforts and Prudent Electrical Practices to Schedule and convey the *entire* Scheduled Amounts during the Facility Term to SCE and SCE shall take delivery of the Scheduled Amounts.

If SCE is acting as Seller's Scheduling Coordinator, Seller shall deliver and convey the *entire* Delivered Amounts during the Facility Term to SCE and SCE shall take delivery of the Delivered Amounts.

Green Attributes. Seller hereby provides and conveys all Green Attributes associated with all electricity generation from the Project to Buyer as part of the Product being delivered. Seller represents and warrants that Seller holds the rights to all Green Attributes from the Project, and Seller agrees to convey and hereby conveys all such Green Attributes to Buyer as included in the delivery of the Product from the Project.

Other Attributes and Benefits. In addition, Seller shall dedicate and convey any and all Capacity Attributes and Resource Adequacy Benefits generated by, associated with or attributable to the Generating Facility during the Term to SCE and SCE shall be given sole title to all such Capacity Attributes and Resource Adequacy Benefits.

Subject to Section 3.01(d), Seller shall, at its own cost, take all reasonable actions, including executing all documents or instruments, necessary to effectuate the use of the Green Attributes, Capacity Attributes and Resource Adequacy Benefits for SCE's sole benefit throughout the Facility Term.

Subject to Section 3.01(d), such actions shall include, without limitation:

- (i) Cooperating with and encouraging the regional entity responsible for resource adequacy administration to certify or qualify the Nameplate Contract Capacity for resource adequacy purposes;
- (ii) Testing the Generating Facility in order to certify the Nameplate Contract Capacity for resource adequacy purposes;
- (iii) Complying with all current and future ISO Tariff provisions that address resource adequacy, including but not limited to provisions regarding performance obligations and penalties; and

-
- (iv) Committing to SCE the full Nameplate Contract Capacity.
 - (b) SCE will have the exclusive right, at any time or from time-to-time during the Facility Term, to sell, assign, convey, transfer, allocate, designate, award, report or otherwise provide any and all such Green Attributes, Capacity Attributes or Resource Adequacy Benefits to third parties.

Subject to Section 3.01(d), Seller shall make good faith efforts to cooperate with and otherwise facilitate the use by any such third party of any Green Attributes, Capacity Attributes or Resource Adequacy Benefits.

- (c) SCE shall be responsible for any costs associated with SCE's accounting for or otherwise claiming Green Attributes, Capacity Attributes and Resource Adequacy Benefits.
- (d) Seller shall not be required to incur out of pocket costs in excess of \$25,000 in any year in order to effectuate the use of the Green Attributes, Capacity Attributes and Resource Adequacy Benefits for SCE's sole benefit throughout the Facility Term or to facilitate the use by any third party transferee of SCE of any Green Attributes, Capacity Attributes or Resource Adequacy Benefits. Seller shall not be required to reduce the output of the Generating Facility in order to effectuate the use of the Green Attributes, Capacity Attributes and Resource Adequacy Benefits for SCE's sole benefit throughout the Facility Term, other than in connection with periodic testing as may be required by the ISO.
- (e) If SCE is not acting as Seller's Scheduling Coordinator, Seller shall convey title to and risk of loss of all Scheduled Amounts to SCE at the Delivery Point.

If SCE is acting as Seller's Scheduling Coordinator, Seller shall convey title to and risk of loss of all Delivered Amounts to SCE at the Delivery Point.

- (f) From the Power Purchase Agreement Effective Date, Seller shall not sell any Product to any entity other than SCE, except that Seller shall have the right to sell into the ISO real-time market (and any other ISO administered market that may from time-to-time be implemented) any electric energy generated by the Generating Facility before the beginning of the Facility Term and sell to others Green Attributes and Capacity Attributes related to such electric energy generation before the beginning of the Facility Term, and to retain all proceeds of such sales.

3.02 Resource Adequacy Benefits.

- (a) Seller grants, pledges, assigns and otherwise commits to SCE the Nameplate Contract Capacity in order to contribute to SCE meeting its resource adequacy obligations (including any RAR) under any Resource Adequacy Rulings.

The contents of this document are subject to restrictions on disclosure as set forth herein.

Seller also represents, warrants and covenants to SCE that Seller:

- (i) Has not used, granted, pledged, assigned or otherwise committed; and
 - (ii) Will not, during the Facility Term use, grant, pledge, assign or otherwise commit, any portion of the Generating Facility to meet the resource adequacy requirements of, or to confer Resource Adequacy Benefits upon, any entity other than SCE.
- (b) If SCE is not acting as Seller's Scheduling Coordinator:
- (i) Seller shall, on a timely basis, submit, or cause Seller's SC to submit to the ISO, Supply Plans that identify and confirm the Resource Adequacy Benefits of the Generating Facility sold to SCE;
 - (ii) No later than the earlier of:
 - (1) Twenty (20) Business Days after the Power Purchase Agreement Effective Date; or
 - (2) Fifteen (15) Business Days before the relevant deadline for any applicable RAR showing;Seller shall cause Seller's SC to certify to SCE that the Supply Plan identifies and credits SCE as the holder of all Resource Adequacy Benefits of the Generating Facility for the Facility Term.
 - (iii) Seller shall indemnify and hold harmless SCE from any monetary penalties or fines (including backstop costs) imposed on SCE by the ISO or a Governmental Authority directly attributable to the failure of Seller or Seller's SC to timely submit Supply Plans that identify SCE's right to the Resource Adequacy Benefits purchased hereunder; *provided that* SCE shall use commercially reasonable efforts (not including expending any money for which Seller has not first agreed in writing to reimburse to SCE) to avoid and mitigate any monetary penalties or fines (including backstop costs). Notwithstanding any such failure by Seller or Seller's SC, Seller's indemnity obligation shall not exceed the pro rata share of Seller's Nameplate Contract Capacity relative to the nameplate capacity of generating resources of other Persons on whom SCE relies for meeting its Resource Adequacy Requirements that fail to timely submit Supply Plans, including, if applicable, SCE.

If Seller fails to pay those monetary penalties or fines (including backstop costs), or fails to reimburse SCE for those monetary penalties or fines (including backstop costs), then SCE may offset amounts

owing to it under this Section 3.02(b)(iii) against any future amounts it may owe to Seller under this Power Purchase Agreement.

3.03 Seller's Obligations to Deliver.

- (a) Seller shall be responsible for obtaining and maintaining any and all interconnection, metering, transmission service rights (including all regulatory approvals) and Permits required to effect delivery of the electric energy from the Generating Facility at the Delivery Point.
- (b) Seller shall secure all Required ISO Agreements, certifications and approvals.
 - (i) Seller's Participating Generator Agreement, Schedule 1, shall:
 - (1) List all Wind Turbines as a single aggregated unit; and
 - (2) Indicate that the generating capacity from the Generating Facility is contracted to SCE under a bilateral agreement; and
 - (ii) Seller's Meter Service Agreement, Schedule 1 shall treat all Wind Turbines as a single generating unit with a single electric energy meter.

3.04 Demonstration of Nameplate Contract Capacity.

- (a) Seller shall, or shall cause a third party to, provide Notice to SCE when the Generating Facility has reached its Initial Operation Date and Seller desires to demonstrate the Nameplate Contract Capacity of the Generating Facility. Such Notice shall identify the Generating Facility and certify that the Nameplate Contract Capacity of such Generating Facility is as set forth in Section 2(c) of the Final Notice to Proceed for the Generating Facility, attached hereto as Exhibit B (or identify any deviations therefrom).
- (b) Within thirty (30) days of SCE's receipt of Seller's Notice as described in Section 3.04(a), SCE shall complete a site visit so that Seller may demonstrate the Nameplate Contract Capacity of the Generating Facility.
- (c) Seller's demonstration of the Nameplate Contract Capacity of the Generating Facility shall consist of (i) demonstrating that all Wind Turbines comprising the Generating Facility are (1) interconnected and metered through an ISO Approved Meter for the Generating Facility; (2) located on the Site, and (3) not previously employed in another generating facility, and (ii) summing the total of the manufacturer's nameplate ratings of all Wind Turbines installed and operating at the time of the site visit, as indicated on the nameplates physically attached to the individual Wind Turbine generators (except that if Seller has been advised of any reductions in such nameplate capacity by the

The contents of this document are subject to restrictions on disclosure as set forth herein.

Wind Turbine manufacturer, it shall so notify SCE and such modified nameplate capacity shall be used). The sum determined in accordance with the foregoing shall be referred to herein as the “Demonstrated Nameplate Contract Capacity” of the Generating Facility.

- (d) If the Demonstrated Nameplate Contract Capacity of the Generating Facility is less than the Nameplate Contract Capacity of the Generating Facility, then the Nameplate Contract Capacity of the Generating Facility shall be reduced to the Demonstrated Nameplate Contract Capacity and the Estimated Annual Production shall be calculated based on a new Final Wind Report using the new Nameplate Contract Capacity.
- (e) If SCE fails to complete its site visit within the required time period (subject to any extensions for Force Majeure), Seller shall be deemed to have demonstrated the Nameplate Contract Capacity, and the Demonstrated Nameplate Contract Capacity shall be the lesser of the Nameplate Contract Capacity set forth in Seller’s Notice delivered pursuant to Section 3.04(a) or in Section 2(c) of the Final Notice to Proceed for the Generating Facility, attached hereto as Exhibit B.
- (f) Neither Party shall have any liability under this Power Purchase Agreement for failure to purchase or deliver Product associated with or attributable to capacity in excess of the Demonstrated Nameplate Contract Capacity (“Unincluded Capacity”); *provided that*, none of Seller, Seller’s Affiliates or their transferees may sell, or enter into an agreement to sell, electric energy, Green Attributes, Capacity Attributes or Resource Adequacy Benefits associated with or attributable to Unincluded Capacity from a generating facility installed at the Site to a party other than SCE for a period of two (2) years following the reduction of the Nameplate Contract Capacity to the Demonstrated Nameplate Contract Capacity pursuant to Sections 3.04(d) or 3.04(e).

The prohibition on contracting and sale in the preceding sentence shall not apply if, prior to entering into the contract or making a sale to a party other than SCE, Seller, Seller’s Affiliates or their transferees provide SCE with a written offer to sell the electric energy, Green Attributes, Capacity Attributes and Resource Adequacy Benefits related to Unincluded Capacity to SCE on terms and conditions materially similar to or no less favorable to SCE than, the terms and conditions contained in this Power Purchase Agreement and SCE fails to accept such offer within thirty (30) days after SCE’s receipt thereof.

3.05 Production and Availability Requirements.

- (a) Introduction.

The contents of this document are subject to restrictions on disclosure as set forth herein.

After the Firm Operation Date, Seller shall pay as liquidated damages any:

- (i) Seller's Annual Shortfall Payment calculated as set forth in Exhibit F;
and
 - (ii) Seller's Long Term Availability Shortfall Payment calculated as set forth in Exhibit O.
- (b) Actual Generating Facility Availability.

Within thirty (30) days after the end of each of first ten Facility Term Years, Seller shall provide SCE Notice of the Generating Facility's actual availability.

Seller's Notice shall include:

- (i) The Actual Generating Facility Annual Availability;
 - (ii) The Actual Generating Facility Long Term Availability (after the end of the fifth and tenth Facility Term Years);
 - (iii) A copy of the Wind Turbine manufacturer's wind turbine availability calculation so long as any of the Wind Turbines are still under warranty;
 - (iv) A summary of availability of each Wind Turbine during the relevant time period;
 - (v) A copy of all supporting data from the Generating Facility's control system;
 - (vi) A letter from the Wind Turbine manufacturer or an independent engineer reasonably acceptable to SCE stating that it has reviewed the calculation methods and results, and found them to be consistent with the Wind Turbine manufacturer's contract guarantee to Seller; and
 - (vii) An attestation from Seller's highest ranking executive that the calculation is accurate.
- (c) SCE's Calculation.

Within sixty (60) days of SCE's receipt of Seller's Notice in accordance with Section 3.05(b), SCE shall provide Seller a Notice which includes a:

- (i) Calculation of Seller's Annual Shortfall Payment in accordance with Exhibit F;

- (ii) Calculation of Seller's Long Term Availability Shortfall Payment in accordance with Exhibit O;
 - (iii) An invoice for any Seller's Annual Shortfall Payment and/or Seller's Long Term Availability Shortfall Payment amounts owed to SCE; and
 - (iv) Annotated work papers, source data and a detailed explanation of the calculation.
- (d) Seller's Payments.

Seller shall have thirty (30) days after receipt of SCE's Notice to review SCE's calculation and either pay the entire Seller's Annual Shortfall Payment and/or Seller's Long Term Availability Shortfall Payment amount claimed by SCE or pay any undisputed portion and provide Notice to SCE of the portion it disputes along with a detailed explanation of, and rationale for, Seller's calculation methodology, annotated work papers and source data.

The Parties shall negotiate in good faith to resolve any disputed portion of the Seller's Annual Shortfall Payment and/or Seller's Long Term Availability Shortfall Payment amount and shall, as part of such good faith negotiations, promptly provide information or data relevant to the dispute as each Party may possess which is requested by the other Party.

If the Parties are unable to resolve a dispute regarding any Seller's Annual Shortfall Payment and/or Seller's Long Term Availability Shortfall Payment amount within thirty (30) days after the sending of a Notice of dispute by Seller, either Party may submit the dispute to arbitration as provided in Article Twelve.

- (e) SCE's Sole and Exclusive Remedy.

SCE's sole and exclusive remedy for Seller's breach of Seller's Annual Energy Obligation, Seller's Annual Availability Obligation and/or Seller's Long Term Availability Obligation shall be the receipt of Seller's Annual Shortfall Payment and/or Seller's Long Term Availability Shortfall Payment.

- (f) Continuing Obligations of Seller.

Notwithstanding any payment of any Seller's Annual Shortfall Payment and/or Seller's Long Term Availability Shortfall Payment, Seller shall remain obligated to convey all Scheduled Amounts, if SCE is not Seller's Scheduling Coordinator, or Delivered Amounts, if SCE is Seller's Scheduling Coordinator and all Green Attributes, Capacity Attributes and Resource Adequacy Benefits to SCE during the Facility Term, as provided in Sections 3.01 and 3.02.

The contents of this document are subject to restrictions on disclosure as set forth herein.

3.06 Metering.**(a) ISO Approved Meter.**

Seller shall:

- (i) Install and pay for any meter and related communications equipment required by the ISO Tariff, the Transmission Provider (in accordance with its tariff) and Seller's Scheduling Coordinator; and
- (ii) Install, within a reasonable time period after Notice from SCE, any meter and related communications equipment reasonably required by SCE outside the scope of its role as Transmission Provider (which equipment and installation will be at SCE's cost).

Such equipment shall include, but not be limited to, an ISO approved revenue quality meter or meters, ISO approved data processing gateway, telemetering equipment and data acquisition services sufficient for monitoring Operation and recording and reporting all electric energy produced by the Generating Facility less Station Use (collectively, the "ISO Approved Meter").

(b) Access to ISO Approved Meter.

- (i) Subject to Section 3.14, Seller shall grant SCE reasonable access to the meter(s) for meter readings and any purpose necessary to effectuate this Power Purchase Agreement.
Seller shall promptly provide SCE access to all meter data both in real time, and at later times as SCE may reasonably request.
- (ii) Prior to the Initial Operation Date, Seller shall provide instructions to the ISO granting authorizations or other documentation sufficient to provide SCE with read-only access to the ISO Approved Meter and to Seller's settlement data on OMAR.
Seller shall promptly inform SCE of meter quantity changes after being aware of, or being informed of, any such changes by the ISO.

(c) ISO Approved Meter Maintenance.

- (i) Seller shall test and calibrate the ISO Approved Meter, as necessary, but in no event shall the period between testing and calibration dates be greater than twenty four (24) months.
- (ii) Seller shall replace the ISO Approved Meter battery at least once every thirty six (36) months.

Notwithstanding the foregoing, in the event the ISO Approved Meter battery fails, Seller shall replace such battery as soon as is reasonably practicable (not to exceed three (3) days after its failure).

- (iii) Seller shall use certified test and calibration technicians to perform any work associated with the ISO Approved Meter.
- (iv) Seller shall inform SCE of test and calibration dates, provide SCE with access to observe and witness such testing and calibration, and provide SCE certified results of tests and calibrations within thirty (30) days after completion.

3.07 Site Control.

- (a) Subject to the terms of the Collateral Assignment Agreement, on or before the Initial Operation Date, and at all times thereafter, Seller shall have "Site Control", which means that Seller shall:
 - (i) Own the Site;
 - (ii) Be the lessee of the Site under a Lease;
 - (iii) Be the holder of a right-of-way grant or similar instrument or an easement or similar right with respect to the Site; or
 - (iv) Be in Control of, or be the managing partner or other person or entity authorized to act in all matters relating to the control and Operation of, the Site and the Generating Facility.
- (b) Seller shall provide SCE with prompt Notice of any change in the status of Seller's Site Control.
- (c) Seller shall provide SCE with Notice of the status of its Site Control prior to commencing construction of the Generating Facility.

3.08 Site Location.

This Power Purchase Agreement is Site specific as set forth in Section 1.01(b). Seller may, with SCE's prior written consent, change the location of the Site; *provided that*, the Interconnection Point is not changed.

Seller shall promptly provide a revised Exhibit 1 to the Final Notice to Proceed for the Generating Facility, attached hereto as Exhibit B, describing any new Site in the event Seller requests SCE's consent to change the Site location.

3.09 Design.

The contents of this document are subject to restrictions on disclosure as set forth herein.

As between Seller and SCE, Seller, at no cost to SCE, shall be responsible for:

- (a) Designing and constructing the Generating Facility.
- (b) Using commercially reasonable efforts to acquire all Permits and other approvals necessary for the construction and Operation of the Generating Facility.
- (c) Providing to SCE, at least thirty (30) days prior to the Expected Initial Operation Date, the following Generating Facility information:
 - (i) Site plan drawings for the Generating Facility;
 - (ii) Electrical one line diagrams;
 - (iii) Major electrical equipment specifications;
 - (iv) General arrangement drawings;
 - (v) Longitude and latitude of each generator;
 - (vi) Artist renderings of the Site, if any;
 - (vii) Aerial photographs of the Site, if any;
 - (viii) Wind Turbine specification; and
 - (ix) Monitoring system diagrams.
- (d) Providing SCE advance Notice at the earliest practicable time of any proposed changes in Seller's Generating Facility with such Notice to include the information set forth in Section 3.09(c) above, along with all specifications and drawings pertaining to any such changes.

3.10 Operation.

- (a) Seller shall Operate the Generating Facility in accordance with Prudent Electrical Practices.
- (b) Seller shall keep a daily operations log for the Generating Facility that shall include information on availability, maintenance outages, circuit breaker trip operations requiring a manual reset, and any significant events related to the Operation of the Generating Facility.

In addition, Seller shall maintain complete records of the Generating Facility's wind speeds and other pertinent meteorological conditions, maintenance

The contents of this document are subject to restrictions on disclosure as set forth herein.

performed, kilowatts, kilovars and kilowatt-hours generated and settings or adjustments of the generator control equipment and protective devices.

Such information shall be provided or made available to SCE within twenty (20) days after any Notice.

- (c) Seller shall keep a maintenance log for the Generating Facility that shall include information on electric energy production, fuel consumption and efficiency (if applicable), availability, maintenance (both breakdown and preventative) performed, outages, changes in operating status, inspections, manufacturer recommended services and replacement, electrical characteristics of the generators, control settings or adjustments of equipment and protective devices.

Information maintained pursuant to this Section 3.10(c) shall be kept for seven (7) years and shall be provided or made available to SCE during such seven (7) years within twenty (20) days after any Notice.

- (d) Seller shall give Notice to SCE of Seller's:
- (i) Unexpected or unscheduled outages by telephoning SCE's Generation Operations Center as soon as practicable, at the telephone number(s) listed in Exhibit C, or by an SCE-provided web-based system that will accommodate communications in a manner consistent with the format required by the ISO ("Web Client") when instructed by SCE.
- (e) Seller shall promptly prepare and provide to SCE upon request using SCE-provided software all reports of actual or forecasted outages that SCE may reasonably require for the purpose of enabling SCE to comply with Section 761.3 of the California Public Utilities Code or any Applicable Law mandating the reporting by investor-owned utilities of expected or experienced outages by electric energy generating facilities under contract to supply electric energy.
- (f) Except as otherwise set forth herein, Seller shall comply with the Scheduling requirements and procedures set forth in Section 3.19 at its sole expense.
- (g) At least thirty (30) days prior to the Initial Operation of the Generating Facility in parallel with the Transmission Provider's electric system, Seller shall provide SCE with all Generating Facility and metering information (on a read-only basis) as may be requested by SCE, including, but not limited to, the following:

For each ISO Approved meter:

- (i) Generating Station/Unit ID;

The contents of this document are subject to restrictions on disclosure as set forth herein.

- (ii) ISO Global Resource ID;
- (iii) ISO Approved Meter Device ID;
- (iv) Password;
- (v) Data path (network (ECN) or modem);
- (vi) If modem, phone number;
- (vii) Copy of meter certification;
- (viii) List of any ISO metering exemptions (if any);
- (ix) Description of any compensation calculations such as transformer losses and line losses.

For the Generating Facility:

- (i) Utility transmission/distribution one line diagram;
- (ii) Physical location, address or descriptive identification;
- (iii) Latitude and longitude;
- (iv) Telephone number on site;
- (v) Telephone number of control room;
- (vi) Telephone number for operational issues;
- (vii) Telephone number for administrative issues.

3.11 Progress Reporting.

Seller shall use commercially reasonable efforts to meet the Milestone Schedule set forth in Exhibit G and avoid or minimize any delays in meeting such schedule. Seller shall provide a monthly written report of its progress toward meeting the Milestone Schedule using the procedures set forth in Exhibit H.

Seller shall include in such report a list of all letters, notices, applications, approvals, authorizations, filings, permits and licenses relating to any Transmission Provider, Governmental Authority or the ISO and shall provide any such documents as may be reasonably requested on Notice from SCE.

In addition, Seller shall advise SCE as soon as reasonably practicable of any problems or issues of which it is aware which may materially impact its ability to meet the Milestone Schedule.

3.12 No Representation by SCE.

Any review by SCE of the design, construction and Operation of the Generating Facility is solely for SCE's information.

By making such review, SCE makes no representation as to the economic and technical feasibility, operational capability, or reliability of the Generating Facility, or that the Generating Facility complies with Applicable Law or the terms of this Power Purchase Agreement, and Seller shall in no way represent to any third party that any such review by SCE constitutes any such representation. Seller is solely responsible for such matters.

3.13 Provision of Information.

Seller shall promptly provide to SCE copies of:

- (a) All agreements with providers of distribution, transmission or interconnection services for the Generating Facility and all amendments thereto, which may be redacted by Seller to eliminate any portions reasonably believed by Seller to contain confidential information;
- (b) All applications and approvals relating to the CEC Certification and Verification, any Permits and PIRP;
- (c) All draft, preliminary, final and revised copies of reports, studies and analyses furnished by the ISO or any Transmission Provider, and any ISO correspondence related thereto, concerning the transmission of electric energy from the Generating Facility to the Delivery Point;
- (d) The Final Wind Report prior to the start of construction of the Generating Facility; and
- (e) Any updates to the Final Wind Report done during the Facility Term.

3.14 SCE's Access Rights.

SCE shall have the right of ingress and egress to examine the Site and Generating Facility during regular business hours for any purpose reasonably connected with this Power Purchase Agreement or the exercise of any and all rights of SCE under Applicable Law or its tariff schedules and rules on file with the CPUC. SCE shall at all times comply with Seller's site safety and security requirements of which SCE has been made aware.

The contents of this document are subject to restrictions on disclosure as set forth herein.

3.15 Reserved.3.16 Obtaining and Maintaining CEC Certification and Verification.

Seller shall follow the appropriate procedures, including, but not limited to, making or supporting timely filings with the CEC, to obtain and maintain CEC Certification and Verification throughout the Facility Term; *provided however that:*

- (a) This obligation shall not apply to the extent that Seller is unable to obtain or maintain CEC Certification and Verification because of a change in the RPS Legislation, or the rules or regulations relating thereto, occurring after the Master Agreement Effective Date; and
- (b) Seller has made commercially reasonable efforts to obtain and maintain CEC Certification and Verification under the then current Applicable Law. Seller shall not be required to incur out of pocket costs in excess of \$25,000 in any year in order to obtain and maintain CEC Certification and Verification under the then current Applicable Law.

3.17 Notice of Cessation or Termination of Service Agreements.

Seller shall provide Notice to SCE within three (3) Business Days of termination of, or cessation of service under, any agreement necessary for the interconnection to the Transmission Provider's electric system or transmission of the electric energy to the Delivery Point, for Scheduling, Forecasting or delivering to SCE, or for metering the Metered Amounts.

3.18 Lost Output Report.(a) Monthly Report; SCE Review.

Commencing on the Initial Operation Date and continuing throughout the Facility Term, Seller shall prepare and provide to SCE a Lost Output Report by the tenth (10th) Business Day following the end of each month in accordance with Exhibit M.

SCE shall have thirty (30) days after receipt of Seller's monthly Lost Output Report to review such report.

Upon SCE's request, Seller shall promptly provide to SCE any additional data and supporting documentation reasonably necessary for SCE to audit and verify any matters in the Lost Output Report.

(b) Disputes of Lost Output.

If SCE disputes Seller's Lost Output calculation, it shall provide Notice to Seller within thirty (30) days after receipt of Seller's Lost Output Report and

The contents of this document are subject to restrictions on disclosure as set forth herein.

include SCE's calculations and other data supporting its position.

The Parties shall negotiate in good faith to resolve any dispute. If the Parties are unable to resolve a dispute within thirty (30) days of SCE's giving the dispute Notice, either Party may submit the dispute to arbitration as provided in Article Twelve.

Seller shall have no right to claim any Lost Output for any month that was not identified in the original Lost Output Report for that month; *provided that*, Seller may supplement the amount of Lost Output claimed ("Supplemental Lost Output") for the month with a supplemental Lost Output Report ("Supplemental Lost Output Report") if Seller can demonstrate that it neither knew nor could it have known through the exercise of reasonable diligence about the Supplemental Lost Output within the foregoing thirty (30) day period and Seller provides the Supplemental Lost Output Report within ten (10) Business Days of learning the facts which provide the basis for the Supplemental Lost Output claim.

(c) Seller's Annual Shortfall Payment Calculation.

The Lost Output amount that shall be used in the Seller's Annual Shortfall Payment calculation, set forth in Exhibit F, shall be the amount calculated after the twelfth (12th) month of the Facility Term Year using the Generating Facility Power Curve derived for each Facility Term Year for which the Lost Output is being calculated.

3.19 Scheduling and Related Obligations.

- (a) During the time period when Section 3.19(b) is not applicable, the following provisions shall apply:
- (i) Seller shall be responsible for obtaining and maintaining any and all Scheduling service required to effect Scheduling of the electric energy from the Generating Facility at the Delivery Point in the form of SC-to-SC Trades. SC-to-SC Trades shall be submitted to SCE using the Web Client.
 - (ii) Seller shall pay all Scheduling Coordinator and any other charges directly caused by, associated with, or allocated to the Scheduling of electric energy from the Generating Facility at the Delivery Point.
 - (iii) Seller shall Schedule or cause to be Scheduled the electric energy generated by the Generating Facility in accordance with all applicable ISO requirements and the provisions of Exhibit D.

The Parties acknowledge that variations between Delivered Amounts and Scheduled Amounts will occur from time to time in the ordinary course of Operation of the Generating Facility due to the nature of the wind resource.

If Seller is not participating in PIRP, and there is a difference between the ISO requirements and Exhibit D, Seller shall be responsible for following the more stringent requirements and, as between the ISO requirements and Exhibit D, conforming to the earlier of any scheduling deadlines.

- (iv) Upon the implementation of MRTU, Seller and SCE shall cause the SC-to-SC Trades to be specific to the resource identification number assigned by the ISO to the Generating Facility, as described in Exhibit 1 to the Final Notice to Proceed for the Generating Facility, attached hereto as Exhibit B.

- (b) In the event that (1) PIRP is eliminated and there is no successor program to PIRP, (2) generating facilities with the size and characteristics of the Generating Facility are not eligible to participate in PIRP or a successor program to PIRP, or (3) MRTU is implemented, Seller is in PIRP and PIRP does not provide monthly netting benefits for Day-Ahead Schedules in the same manner as of the Master Agreement Effective Date for Hour-Ahead Schedules, then SCE shall act as Seller's Scheduling Coordinator and the following provisions shall apply:
 - (i) Seller shall comply with all applicable ISO Tariff procedures, protocol, rules and testing requirements required for SCE to submit SC Schedules for the electric energy produced by the Generating Facility.
 - (ii) Cooperation with SCE as Scheduling Coordinator.
 - (1) At least thirty (30) days prior to the later of: (A) Initial Synchronization, or (B) SCE becoming Seller's Scheduling Coordinator, Seller shall take all actions and execute and deliver to SCE all documents necessary to authorize or designate SCE as Seller's Scheduling Coordinator during the period that begins at Initial Synchronization and ends at the Initial Operation Date ("Startup Period"), if SCE is to act as Seller's Scheduling Coordinator during the Startup Period, and throughout the remainder of the Facility Term.
 - (2) Seller shall not authorize or designate any other party to act as Scheduling Coordinator, nor shall Seller perform, for its own benefit, the duties of Scheduling Coordinator.

The contents of this document are subject to restrictions on disclosure as set forth herein.

(iii) Replacement of Scheduling Coordinator.

At least forty-five (45) days prior to the end of the Facility Term, or as soon as practicable before the date of any termination of this Power Purchase Agreement prior to the end of the Facility Term, Seller shall take all actions necessary to terminate the designation of SCE as Seller's Scheduling Coordinator. These actions include, but shall not be limited to:

- (1) Seller shall submit to the ISO a designation of a new Scheduling Coordinator for Seller to replace SCE;
 - (2) Seller shall cause the newly designated Scheduling Coordinator to submit a letter to the ISO accepting the designation; and
 - (3) Seller shall inform SCE of the last date on which SCE will be Seller's Scheduling Coordinator.
- (iv) Upon Notice from SCE, Seller shall promptly curtail the production of the Generating Facility. Such Notice shall be provided to Seller only in the event SCE, as Seller's Scheduling Coordinator, is instructed by the ISO to curtail Seller's Generating Facility in order to respond to an ISO Forecasted Over-Generation Condition, an ISO Declared Over-Generation Condition or an Emergency.

Notwithstanding the foregoing, except as may be required in order to respond to any Emergency, SCE shall:

- (1) Limit the duration of any curtailment order to a maximum of fifteen (15) consecutive hours;
 - (2) Not issue more than one curtailment order during any twenty-four (24) hour period; and
 - (3) Limit the curtailment duration in any Facility Term Year to a maximum of two hundred (200) hours.
- (v) Seller shall comply with Section 5 of Exhibit D.
- (vi) Forecasting.

Seller shall Forecast or cause to be Forecasted the available capacity, in MWs, of the Generating Facility, in accordance with the provisions of Exhibit Q.

(vii) Scheduled Outages.

The contents of this document are subject to restrictions on disclosure as set forth herein.

- (1) No later than five (5) Business Days prior to the dates required by the ISO for delivery of schedules for planned outages (which such ISO required delivery dates are currently January 15th, April 15th, July 15th and October 15th of each calendar year during the Facility Term), and at least sixty (60) days prior to the later of: (A) Initial Synchronization, or (B) SCE becoming Seller's Scheduling Coordinator, Seller shall submit to SCE its schedule of proposed planned outages ("Outage Schedule") for the subsequent twenty four-month period using the Web Client. If Seller fails to submit an Outage Schedule for any period as required under this Section 3.19, then Seller shall not be permitted to schedule or have any planned outages with respect to such period. The foregoing shall not prevent Seller from modifying its Outage Schedule in cooperation with SCE and the ISO. SCE shall provide Notice to Seller in the event that the ISO changes the ISO required delivery dates for schedules for planned outages. In addition, no later than thirty (30) days prior to October 15 of each year, Seller shall submit to SCE its estimate of its planned outages for the following year.
- (2) Seller shall provide the following information for each proposed planned outage:
 - (A) Start date and time;
 - (B) End date and time; and
 - (C) Capacity expected to be online, in MW, during the planned outage.
- (3) Within twenty (20) Business Days after SCE's receipt of an Outage Schedule, SCE shall notify Seller in writing of any reasonable request for changes to the Outage Schedule, and Seller shall, consistent with Prudent Electrical Practices and as permitted by the ISO, accommodate SCE's requests regarding the timing of any planned outage.
- (4) Seller shall cooperate with SCE to arrange and coordinate all Outage Schedules with the ISO.
- (5) In the event a condition occurs at the Generating Facility which causes Seller to revise its planned outages, Seller shall provide Notice to SCE, using the Web Client, of such change (including an estimate of the length of such planned outage) as

soon as practicable after the condition causing the change becomes known to Seller.

- (6) Seller shall promptly prepare and provide to SCE upon request, using the Web Client, all reports of actual or forecasted outages that SCE may reasonably require for the purpose of enabling SCE to comply with Section 761.3 of the California Public Utilities Code or any Applicable Law mandating the reporting by investor owned utilities of expected or experienced outages by electric energy generating facilities under contract to supply electric energy.
- (viii) ISO Charges, ISO Sanctions and SCE Penalties.
- (1) During the Startup Period, Seller shall be entitled to all payments or credits from the ISO, and shall be responsible for all ISO Charges and ISO Sanctions, if any, attributable or assessed for energy delivered by Seller to the ISO real-time market (and any other ISO administered market that may from time-to-time be implemented). Notwithstanding any Forecast, Seller may direct SCE to, and SCE shall, Schedule less energy than Seller expects to generate during the Startup Period, so long as Seller is in compliance with the ISO Tariff.
- (2) Commencing upon the later of the Initial Operation Date or the date on which SCE becomes Seller's Scheduling Coordinator and continuing throughout the Facility Term, Seller shall have no responsibility for ISO Charges attributable to or assessed for energy Scheduled by SCE, or delivered by Seller to SCE.
- In the event Seller fails to comply with the availability forecasting provisions set forth in Exhibit Q or any ISO Tariff or ISO directives as required under Exhibit R, Seller may be liable to pay an SCE Penalty and/or ISO Sanction, each as set forth in Exhibit R, which shall be SCE's sole and exclusive remedy for such failure to comply.
- (3) In no event shall Seller be responsible for ISO Charges, ISO Sanctions or SCE Penalties to the extent attributable to the fault or gross negligence of SCE, including any inaccuracy in the SC Schedules submitted by SCE under this Power Purchase Agreement.
- (4) If Seller disputes any ISO Charge or ISO Sanction, Seller shall provide Notice to SCE of such dispute within the time period allowed for disputing payments as set forth in Section 4.03.

The contents of this document are subject to restrictions on disclosure as set forth herein.

(ix) Actual Availability Report.

- (1) Commencing upon the later of the Initial Operation Date or the date on which SCE becomes Seller's Scheduling Coordinator, Seller shall prepare and provide to SCE a report with the Actual Available Capacity of the Generating Facility (an "Actual Availability Report") for each month. Such report shall be in the form set forth in Exhibit S and shall be delivered to SCE no later than the seventh (7th) Business Day following the end of the month which is the subject of the Actual Availability Report.
- (2) Upon SCE's reasonable request, Seller shall promptly provide to SCE any additional data and supporting documentation necessary for SCE to audit and verify any matters set forth in the Actual Availability Report.

**** End of ARTICLE THREE ****

ARTICLE FOUR. SCE'S OBLIGATIONS

4.01 Obligation to Pay.

- (a) Subject to any obligation of SCE to make ISO Change Cost Payments to Seller under Article 11, for Seller's *full* compensation under this Power Purchase Agreement, SCE shall make monthly Energy Payments to Seller during the Facility Term calculated in the manner described in Section 4.02.
- (b) SCE shall not be obligated to pay Seller for any electric energy prior to the commencement of the Facility Term
- (c) If SCE is not Seller's Scheduling Coordinator, SCE shall not be obligated to pay Seller for any electric energy that is not Scheduled by or on behalf of Seller as a result of any circumstance, other than gross negligence or willful misconduct by SCE, including, without limitation:
 - (i) An outage of the Generating Facility;
 - (ii) A Force Majeure under Article Five;
 - (iii) A reduction or curtailment of SC Schedules ordered by the ISO; or
 - (iv) A reduction or curtailment of SC Schedules pursuant to the terms of an agreement between Seller and a Transmission Provider.
- (d) If SCE is acting as Seller's Scheduling Coordinator, SCE shall not be obligated to pay Seller for any electric energy that is not delivered by Seller as a result of any circumstance, other than gross negligence or willful misconduct by SCE, including, without limitation:
 - (i) An outage of the Generating Facility;
 - (ii) A Force Majeure under Article Five;
 - (iii) A reduction or curtailment of SC Schedules ordered by the ISO; or
 - (iv) A reduction or curtailment of SC Schedules pursuant to the terms of an agreement between Seller and a Transmission Provider.

4.02 Payments and Adjustments.

- (a) Energy Payment Calculations.
 - (i) If SCE is not acting as Seller's Scheduling Coordinator, for the purpose of calculating monthly Energy Payments, Scheduled Amounts

The contents of this document are subject to restrictions on disclosure as set forth herein.

shall be time-differentiated according to the TOD Periods and weighted by the Energy Payment Allocation Factors set forth in Exhibit K.

As set forth in Exhibit K, TOD Periods for the winter season shall be mid-peak, off-peak and super off-peak and TOD Periods for the summer season shall be on-peak, mid-peak and off-peak.

Monthly Energy Payments shall equal the sum of the monthly TOD Period Energy Payments for all TOD Periods in the month. Each monthly TOD Period Energy Payment shall be calculated pursuant to the following formula, where "n" is the TOD Period being calculated:

$$\text{TOD PERIOD}_n \text{ ENERGY PAYMENT} = A \times B \times C$$

Where:

A = Energy Price in \$/kWh (i.e., (\$/MWh)/1000).

B = Energy Payment Allocation Factor, set forth in Exhibit K, for the TOD Period being calculated.

C = The sum of Scheduled Amounts in all hours for the TOD Period being calculated in kWh.

- (ii) If SCE is acting as Seller's Scheduling Coordinator, for the purpose of calculating monthly Energy Payments, Delivered Amounts shall be time-differentiated according to the TOD Periods and weighted by the Energy Payment Allocation Factors set forth in Exhibit K.

As set forth in Exhibit K, TOD Periods for the winter season shall be mid-peak, off-peak and super off-peak and TOD Periods for the summer season shall be on-peak, mid-peak and off-peak.

Monthly Energy Payments shall equal the sum of the monthly TOD Period Energy Payments for all TOD Periods in the month. Each monthly TOD Period Energy Payment shall be calculated pursuant to the following formula, where "n" is the TOD Period being calculated:

$$\text{TOD PERIOD}_n \text{ ENERGY PAYMENT} = A \times B \times C$$

Where:

A = Energy Price in \$/kWh (i.e., (\$/MWh)/1000).

B = Energy Payment Allocation Factor, set forth in Exhibit K, for the TOD Period being calculated.

The contents of this document are subject to restrictions on disclosure as set forth herein.

C = The sum of Delivered Amounts in all hours for the TOD Period being calculated in kWh.

(b) Payment Adjustments.

If, in any Settlement Interval, the Scheduled Amounts deviate from the Delivered Amounts by more than plus or minus three percent ($\pm 3\%$) of the Delivered Amounts, *then* Seller's monthly Energy Payment may be subject to an adjustment calculated by SCE in accordance with the procedures set forth in Exhibit E.

Such payment adjustments shall *not* apply so long as:

- (i) Seller is Scheduling through an independent third party approved by SCE who utilizes, or submits SC Schedules based upon, forecasting and Scheduling methodologies acceptable to SCE in its reasonable discretion;
- (ii) Seller is and remains a Participating Intermittent Resource and participates in the PIRP or any successor ISO program;
- (iii) Seller is Scheduling through an independent third party approved by SCE who utilizes, or submits SC Schedules based upon, forecasting and Scheduling methodologies materially similar to that utilized in the PIRP as of the Master Agreement Effective Date; or
- (iv) SCE is acting as Seller's Scheduling Coordinator under Section 3.19(b) or Section 11.04(a)(ii).

4.03 Payment Statement and Payment.

- (a) No later than thirty (30) days after the end of each calendar month after Initial Synchronization and during the Facility Term (or the last day of February if the statement is being sent in February), or the last Business Day of the month if such 30th day (or 28th or 29th day for February) is a weekend day or holiday, during which:
 - (i) Scheduled Amounts or Delivered Amounts (as applicable) are provided to SCE;
 - (ii) If SCE is acting as Seller's Scheduling Coordinator, ISO Charges, ISO Sanctions or any SCE Penalties are incurred; or
 - (iii) Payment adjustments are made as provided in Section 4.02(b) or below;

SCE shall do each of the following:

The contents of this document are subject to restrictions on disclosure as set forth herein.

-
- (iv) Send a statement to Seller showing:
 - (1) If SCE is acting as Seller's Scheduling Coordinator, the sum of the ISO Charges and credits that are directly assigned by the ISO to the ISO Global Resource ID(s) for the Generating Facility for energy delivered to the real-time market during the Startup Period;
 - (2) If SCE is not acting as Seller's Scheduling Coordinator, the Scheduled Amounts for each TOD Period during the month for which the payment is being made;
 - (3) If SCE is acting as Seller's Scheduling Coordinator, the Delivered Amounts for each TOD Period during the month for which payment is being made;
 - (4) A calculation of the amount payable to Seller for the month pursuant to Section 4.02(a);
 - (5) A calculation of any payment adjustments pursuant to Section 4.02(b);
 - (6) If SCE is acting as Seller's Scheduling Coordinator, the ISO Charges, ISO Sanctions and SCE Penalties pursuant to Exhibit R; and
 - (7) A calculation of the net amount due Seller.
 - (v) Send to Seller, via wire transfer, SCE's payment of said net amount, plus a Simple Interest Payment calculated using the Interest Rate and the number of days that the payment is late.
 - (b) In the event that:
 - (i) If SCE is acting as Seller's Scheduling Coordinator, the ISO has recalculated the ISO Charges or credits for energy delivered to a real-time market during the Startup Period;
 - (ii) If SCE is acting as Seller's Scheduling Coordinator, a calculation of ISO Charges or ISO Sanctions is incorrect as a result of inaccurate meters, the corrections of data by the ISO in OMAR, or a recalculation of ISO Charges or ISO Sanctions by the ISO; or
 - (iii) A calculation of Metered Amounts for any purpose hereunder is incorrect as a result of inaccurate meters or the correction of data by the ISO in OMAR;

The contents of this document are subject to restrictions on disclosure as set forth herein.

SCE shall promptly recompute Metered Amounts, ISO Charges or ISO Sanctions (as applicable) for the period of the inaccuracy based upon an adjustment of inaccurate meter readings or recalculated ISO Charges or ISO Sanctions in accordance with the ISO Tariff.

SCE shall also promptly recompute any payment affected by the inaccuracy. Any amount due from SCE to Seller, or Seller to SCE, as the case may be, shall be made as an adjustment to the next monthly payment statement that is calculated after SCE's recomputation using corrected measurements. In the event that the recomputation results in a net amount owed to SCE after offsetting any amounts owing to Seller as shown on the next monthly payment statement, any such additional amount still owing to SCE shall be offset on Seller's next monthly payment statement.

At SCE's discretion, SCE may offset any remaining amount owed SCE on any subsequent monthly payment statement to Seller or invoice Seller for such amount, in which case Seller must pay the amount owing to SCE within twenty (20) days after receipt of such invoice.

If SCE is acting as Seller's Scheduling Coordinator, within sixty (60) days after receipt of the relevant information from the ISO, SCE shall make payment adjustments arising from a recalculation of ISO Charges (during the Startup Period), ISO Sanctions or SCE Penalties or as a result of inaccurate meters, including, if applicable, after the end of the Facility Term; *provided that* the Parties shall be deemed to have waived any such payment adjustments which are not communicated as provided in this Section 4.03 within twenty-eight (28) months from the end of the Facility Term. Adjustment payments for meter inaccuracy shall not bear interest.

- (c) SCE reserves the right to apply amounts that would otherwise be due to Seller under this Power Purchase Agreement as an offset in payment of any amounts owing and unpaid by Seller to SCE under this Power Purchase Agreement.

Nothing in this Section 4.03 shall limit SCE's rights under applicable tariffs, other agreements between the Parties or Applicable Law.

- (d) Except as provided in Section 4.03(b) and as otherwise provided in this Section 4.03(d), if within forty five (45) days of receipt of SCE's monthly payment statement, Seller does not give Notice to SCE of an error, *then* Seller shall be deemed to have waived any error in SCE's statement, computation and payment, and the statement shall be conclusively deemed correct and complete; *provided, however*, that if an error is identified by Seller as a result of settlement, audit or other information provided to Seller by SCE, the ISO or any other third party not under the control of, or an Affiliate of, Seller, after the expiration of the original forty-five (45) day period, Seller shall have an additional forty-five (45) days from the date on which it receives the

The contents of this document are subject to restrictions on disclosure as set forth herein.

information from SCE, the ISO or such third party in which to give Notice to SCE of the error identified by such settlement, audit or other information.

If Seller identifies an error in Seller's favor and SCE agrees that the identified error occurred, SCE shall reimburse Seller for the amount of the underpayment caused by the error and apply the additional payment to the next monthly statement that is calculated.

If Seller identifies an error in SCE's favor and SCE agrees that the identified error occurred, SCE may offset the amount of overpayment caused by the error against amounts otherwise owed to Seller and apply the offset to the next monthly payment statement that is calculated.

Late payments to Seller resulting from SCE's errors, or overpayments to Seller by SCE, shall include a Simple Interest Payment calculated using the Interest Rate and the number of days between the date due (or, in the case of overpayments by SCE, commencing five (5) Business Days from the date SCE provides Notice of such overpayments to Seller) and the date paid; *provided, however*, that changes made because of settlement, audit or other information provided by the ISO or any other third party not under the control of, or an Affiliate of, Seller, and not available to SCE when it rendered its original payment statement shall not bear interest.

In the event that the recomputation results in a net amount still owing to SCE after offsetting any amounts owed to Seller, the next monthly payment statement shall show a net amount owing to SCE.

At SCE's discretion, SCE may offset this net amount owed SCE on any subsequent monthly payment statement to Seller or invoice Seller for such amount, in which case Seller must pay the amount owing to SCE within twenty (20) days after receipt of such invoice.

The Parties shall negotiate in good faith to resolve any disputes regarding claimed errors in a payment statement.

Any disputes which the Parties are unable to resolve through negotiation may be submitted for resolution through mediation and arbitration as provided in Article Twelve.

4.04 Cooperation with Seller and Scheduling.

If SCE is not acting as Seller's Scheduling Coordinator, SCE, at its own cost and expense, shall cooperate reasonably with Seller to permit it to effectuate its Scheduling obligations hereunder.

4.05 SCE as Scheduling Coordinator.

- (a) In the event that Section 3.19(b) is applicable, then, commencing upon the later of: (i) Initial Synchronization, or (ii) the date upon which SCE becomes Seller's Scheduling Coordinator pursuant to Section 3.19(b), SCE shall act as Scheduling Coordinator (without receiving any separate remuneration for such

The contents of this document are subject to restrictions on disclosure as set forth herein.

services other than as set forth in Section 4.05(d)), on behalf of Seller, and shall submit bids and SC Schedules to the ISO in accordance with ISO Tariff protocols.

(b) Duties of Scheduling Coordinator.

- (i) SCE shall timely submit all notices and updates required under the ISO Tariff regarding the Generating Facility's status to the ISO and promptly provide all communications to Seller regarding the Generating Facility from the ISO (which may be made available via the Web Client).
- (ii) If SCE is acting as Seller's Scheduling Coordinator during the Startup Period, then, during the Startup Period, SCE shall forward to Seller, within sixty (60) days of receipt, all ISO revenues (including credits and other payments) incurred or received as a result of providing Scheduling Coordinator services, including costs and revenues associated with ISO dispatches. In addition, during the Startup Period, SCE shall submit SC Schedules in compliance with the direction of Seller.
- (iii) In the event SCE believes that any ISO Charge (during the Startup Period) or ISO Sanction is incorrect and disputable under the ISO Tariff (with respect to which SCE shall provide Notice to Seller containing information of its dispute) or upon Notice by Seller of any dispute of an ISO Charge (during the Startup Period) or ISO Sanction, SCE shall dispute any such ISO Charge (during the Startup Period) or ISO Sanction in accordance with the procedures set forth under the ISO Tariff.
- (iv) SCE shall, upon the request of Seller (which request may be made periodically on a reasonable basis during the Startup Period and no more than once per year during the Facility Term), provide Seller with the Scheduled Amounts for the Generating Facility.

(c) Termination of Scheduling Coordinator.

SCE shall submit a letter to the ISO identifying the date on which SCE resigns as Seller's Scheduling Coordinator, on the first to occur of either:

- (i) Thirty (30) days prior to the end of the Facility Term; or
- (ii) The date of any early termination of this Power Purchase Agreement.

(d) ISO Charges.

Except during the Startup Period, and except as set forth in Section 3.19(b) and Exhibit R (with respect to Seller's obligation to pay ISO Sanctions), SCE shall (i) be responsible for ISO Charges, and (ii) receive all ISO revenues (including credits and other payments) incurred or received as a result of providing Scheduling Coordinator services or attributable to generation from the Generating Facility, including costs and revenues associated with ISO dispatches.

- (e) SCE shall at all times perform its Scheduling Coordinator obligations in a reasonable and prudent manner and in compliance with all applicable ISO rules and protocols.

4.06 Interest Payments on Cash Deposits.

- (a) SCE shall make monthly Simple Interest Payments, calculated using the Federal Funds Effective Rate, to Seller on cash amounts posted for the Performance Assurance.
- (b) Upon receipt of a monthly invoice (provided by Seller to the SCE Manager of Credit and Collateral designated in Exhibit C) that sets forth the calculation of the Simple Interest Payment amount due, SCE shall make payment thereof by the later of the fifth Local Business Day:
- (i) Of the first month after the last month to which the invoice relates; and
 - (ii) After the day on which such invoice is received
- provided that,*
- (iii) No Event of Default has occurred and is continuing with respect to Seller; and
 - (iv) No Early Termination Date for which any unsatisfied payment obligation of Seller exists, has occurred or has been designated as the result of an Event of Default by Seller.
- (c) On or after the occurrence of an Event of Default by Seller or an Early Termination Date as a result of an Event of Default by Seller, SCE shall retain any such Simple Interest Payment amount as an additional Performance Assurance amount hereunder until the obligations of Seller under this Power Purchase Agreement have been satisfied in the case of an Early Termination Date or for so long as such Event of Default is continuing in the case of an Event of Default.

*** End of ARTICLE FOUR ***

The contents of this document are subject to restrictions on disclosure as set forth herein.

ARTICLE FIVE. FORCE MAJEURE5.01 No Default for Force Majeure.

Neither Party shall be considered to be in default in the performance of any of its obligations set forth in this Power Purchase Agreement; except for obligations to pay money, when and to the extent failure of performance is caused by Force Majeure.

5.02 Requirements Applicable to the Claiming Party.

If a Party, because of Force Majeure, is rendered wholly or partly unable to perform its obligations when due under this Power Purchase Agreement, that Party (the "Claiming Party"), shall be excused from whatever performance is affected by the Force Majeure to the extent so affected.

In order to be excused from its performance obligations hereunder by reason of Force Majeure:

- (a) The Claiming Party, within fourteen (14) days after the later of (i) the initial occurrence of the claimed Force Majeure, or (ii) the date on which the claimed Force Majeure first prevents or delays performance under this Power Purchase Agreement, must give the other Party Notice describing the particulars of the occurrence; and
- (b) The Claiming Party must provide timely evidence reasonably sufficient to establish that the occurrence constitutes Force Majeure as defined in this Power Purchase Agreement.

The suspension of the Claiming Party's performance due to Force Majeure shall be of no greater scope and of no longer duration than is required by the Force Majeure.

In addition, the Claiming Party shall use commercially reasonable and diligent efforts to remedy its inability to perform.

This section shall not require the settlement of any strike, walkout, lockout or other labor dispute on terms which, in the sole judgment of the Claiming Party, are contrary to its interest.

It is understood and agreed that the settlement of strikes, walkouts, lockouts or other labor disputes shall be at the sole discretion of the Claiming Party.

When the Claiming Party is able to resume performance of its obligations under this Power Purchase Agreement, the Claiming Party shall give the other Party prompt Notice to that effect.

The contents of this document are subject to restrictions on disclosure as set forth herein.

5.03 Expected Initial Operation Date or Expected Construction Commencement Date Extension.

If Force Majeure occurs prior to the Expected Initial Operation Date or the Expected Construction Commencement Date which prevents Seller from achieving the Initial Operation Date by the Expected Initial Operation Date or which prevents Seller from commencing construction by the Expected Construction Commencement Date, *then* the Expected Initial Operation Date or the Expected Construction Commencement Date may, subject to Seller's compliance with its obligations as the Claiming Party under Section 5.02, be extended by Seller on a day-for-day basis for the duration of the Force Majeure.

5.04 Firm Operation Date Extension.

If Force Majeure occurs at any time after the commencement of the Facility Term, but prior to the Firm Operation Date, which prevents Seller from demonstrating the Nameplate Contract Capacity as provided in Section 3.04, *then* the Firm Operation Date may, subject to Seller's compliance with its obligations as the Claiming Party under Section 5.02, be extended by Seller on a day-for-day basis for the duration of the Force Majeure.

5.05 Termination.

Either Party may terminate this Power Purchase Agreement on Notice, which shall be effective five (5) Business Days after such Notice is provided, in the event of Force Majeure which extends for more than three hundred sixty-five (365) consecutive days and which prevents either Party's substantial performance under this Power Purchase Agreement; *provided that*, SCE shall not have the right to terminate this Power Purchase Agreement under this Section 5.05 as a result of a failure of Seller to timely obtain interconnection or transmission service for the Generating Facility, other than due to the fault or gross negligence of Seller or Developer (but only to the extent that Developer is responsible for, or is, pursuing such interconnection or transmission facilities for the benefit of Seller).

*** End of ARTICLE FIVE ***

The contents of this document are subject to restrictions on disclosure as set forth herein.

ARTICLE SIX. EVENTS OF DEFAULT: REMEDIES

6.01 Events of Default.

An "Event of Default" shall mean, with respect to a Party (a "Defaulting Party"), the occurrence of any of the following:

- (a) With respect to either Party:
 - (i) Any representation or warranty made by such Party herein is false or misleading in any material respect when made or when deemed made or repeated if the representation or warranty is continuing in nature, if:
 - (1) Such misrepresentation or breach of warranty is not remedied within ten (10) Business Days after Notice; or
 - (2) Such inaccuracy is not capable of a cure, but the non-breaching Party's damages resulting from such inaccuracy can reasonably be ascertained and the payment of such damages is not made within ten (10) Business Days after a Notice of such damages is provided by the non-breaching Party to the breaching Party;
 - (ii) Except for an obligation to make payment when due, the failure to perform any material covenant or obligation set forth in this Power Purchase Agreement (except to the extent constituting a separate Event of Default or to the extent excused by a Force Majeure) if such failure is not remedied within thirty (30) days after Notice of such failure, which Notice sets forth in reasonable detail the nature of the failure; *provided that*, if such failure is not reasonably capable of being cured within the thirty (30) day cure period specified above, the Party shall have such additional time (not exceeding an additional one hundred twenty (120) days) as is reasonably necessary to cure such failure, so long as such Party promptly commences and diligently pursues such cure;
 - (iii) A Party fails to make when due any payment (other than amounts disputed in good faith in accordance with the terms of this Power Purchase Agreement) due and owing under this Power Purchase Agreement and such failure is not cured within five (5) Business Days after Notice of failure;
 - (iv) Except as expressly set forth in Section 6.01(b), the failure of such Party to satisfy the creditworthiness and collateral requirements in Article Eight and such failure is not cured within three (3) Business Days after Notice of such failure;

The contents of this document are subject to restrictions on disclosure as set forth herein.

- (v) A Party becomes Bankrupt; or
 - (vi) A Party consolidates or amalgamates with, or merges with or into, or transfers all or substantially all of its assets to, another entity and, at the time of such consolidation, amalgamation, merger or transfer, the resulting, surviving or transferee entity fails to assume all the obligations of such Party under this Power Purchase Agreement to which it or its predecessor was a party by operation of law or pursuant to an agreement reasonably satisfactory to the other Party;
- (b) With respect to Seller's Guarantor:
- (i) If any representation or warranty made by a Guarantor in connection with this Power Purchase Agreement is false or misleading in any material respect when made or when deemed made or repeated if the representation or warranty is continuing in nature and the misrepresentation or breach of warranty is not remedied (including through the provision of an alternative Guaranty Agreement or other Performance Assurance) within ten (10) Business Days after Notice;
 - (ii) The failure of a Guarantor to make any payment required or to perform any other material covenant or obligation in any guaranty made in connection with this Power Purchase Agreement and such failure shall not be remedied within three (3) Business Days after Notice;
 - (iii) A Guarantor becomes Bankrupt and Seller fails to procure a replacement Guaranty Agreement or to provide other Performance Assurance within five (5) Business Days, or if paragraphs (c) or (e) in the definition of "Bankrupt" apply, then five (5) Business Days after Notice;
 - (iv) The failure of a Guaranty Agreement to be in full force and effect for purposes of this Power Purchase Agreement (other than in accordance with its terms);
 - (v) A Guarantor repudiates, disaffirms, disclaims, or rejects, in whole or in part, or challenges the validity of any Guaranty Agreement given to SCE and Seller fails to procure a replacement Guaranty Agreement or other Performance Assurance within five (5) Business Days of Notice;
 - (vi) The occurrence and continuation of an "event of default" or other similar condition or event (but not an event or circumstance that would become an "event of default" or other similar condition or event with notice and/or the passage of time) under one or more agreements or instruments of Guarantor, individually or collectively, relating to indebtedness of the Guarantor for borrowed money in the aggregate

The contents of this document are subject to restrictions on disclosure as set forth herein.

- amount of not less than the Cross Default Amount, which results in such indebtedness becoming, or becoming capable at such time of being declared, immediately due and payable; or
- (vii) The occurrence and continuation of a default by Guarantor in making on the due date therefore one or more payments, individually or collectively, in an aggregate amount of *not less than* the applicable Cross Default Amount;
- (c) With respect to Seller, if at any time during the Facility Term:
- (i) The Metered Amounts plus Lost Output in any consecutive six (6) month period are not at least 10 percent (10%) of the expected output for such period as derived from the Estimated Annual Production, and Seller fails to demonstrate to SCE's reasonable satisfaction, within ten (10) Business Days after Notice from SCE, a legitimate reason for such failure;
 - (ii) If SCE is not acting as Seller's Scheduling Coordinator, Seller or Seller's Scheduling Coordinator intentionally or knowingly delivers, Schedules, or attempts to deliver or Schedule at the Delivery Point for sale under this Power Purchase Agreement electric energy that was not in fact generated by the Generating Facility, except in the ordinary course of Scheduling where, notwithstanding Seller's good faith efforts, the Scheduled Amounts may exceed the Delivered Amounts in any hour as permitted by and subject to the ISO Tariff;
 - (iii) If SCE is acting as Seller's Scheduling Coordinator, Seller intentionally or knowingly delivers, Forecasts, or attempts to deliver or Forecast at the Delivery Point for sale under this Power Purchase Agreement electric energy that was not in fact generated by the Generating Facility;
 - (iv) Seller installs Demonstrated Nameplate Contract Capacity in excess of the Nameplate Contract Capacity set forth in Section 1.01(d) as it may be reduced pursuant to Sections 3.04(d) or 3.04(e) and attempts to sell the output of such excess capacity to SCE, and such Demonstrated Nameplate Contract Capacity is not permanently disconnected from the ISO Grid within five (5) Business Days after Notice from SCE and removed within thirty (30) days after Notice from SCE;
 - (v) Seller removes from the Site equipment upon which the Nameplate Contract Capacity has been based, except for the purposes of replacement, refurbishment, repair or maintenance, and such equipment or a suitable replacement reasonably acceptable to SCE is not returned within thirty (30) Business Days after Notice from SCE;

The contents of this document are subject to restrictions on disclosure as set forth herein.

-
- (vi) Seller fails to comply with its obligations under Section 3.16 and fails to cure such failure and resume performance with such obligations within three (3) Business Days after Notice from SCE;
 - (vii) Subject to Section 2.03(b)(iv)(5) and Section 3.16, any electrical output from the Generating Facility sold or to be sold to SCE hereunder fails to meet the qualifications for output from an ERR;
 - (viii) Seller fails to take any actions necessary to dedicate, convey or effectuate the use of any and all Green Attributes, Capacity Attributes and Resource Adequacy Benefits for SCE's sole benefit as specified in Section 3.01 and 3.02 and subject to the limitations therein and such failure is not cured within ten (10) days of Notice of such failure; *provided that*, if such failure is not reasonably capable of being cured within such ten (10) days, Seller shall have such additional time (not exceeding an additional one hundred twenty (120) days) as is reasonably necessary to cure such failure, so long as Seller promptly commences and diligently pursues such cure; or
 - (ix) On or after the Initial Operation Date, a termination of, or cessation of service under, any agreement necessary for the interconnection of the Generating Facility to the Transmission Provider's electric system or transmission of the electric energy to the Delivery Point, for Scheduling to SCE, or for metering the Metered Amounts and such service is not reinstated, or alternative arrangements implemented, within one hundred and twenty (120) days after such termination or cessation;
- (d) With respect to Seller, if at any time:
- (i) Subject to the terms of the Collateral Assignment Agreement, Seller does not own or control the Generating Facility or have the authority over the Site as required in Section 3.07(a) and such failure is not cured within thirty (30) days after Seller providing Notice in accordance with Section 3.07(b);
 - (ii) The Generating Facility consists of an ERR type(s) different than that specified in Section 1.01(c);
 - (iii) Seller fails to comply with its obligations under Section 2.03(b)(iv)(5) and fails to cure such failure and resume performance with such obligations within three (3) Business Days after Notice from SCE; or
 - (iv) Subject to the terms of the Subordination Agreement and the Collateral Assignment Agreement, Seller defaults under any Security Document and such default is not cured within the applicable cure period, if any,

The contents of this document are subject to restrictions on disclosure as set forth herein.

set forth in such Security Document, or Seller repudiates, disaffirms, disclaims, or rejects, in whole or in part, or challenges the validity of, any of the Security Documents;

- (e) With respect to SCE, if at any time during the Facility Term, SCE fails to take delivery of the Scheduled Amounts (if SCE is not Seller's Scheduling Coordinator) or to take delivery of the Delivered Amounts (if SCE is Seller's Scheduling Coordinator) as required hereunder, and such failure is not cured within five (5) Business Days after Notice of failure from Seller.

A default under this Power Purchase Agreement shall not constitute a default under the Master Agreement unless the event or circumstance giving rise to the default also constitutes a default under such Master Agreement. A default under the Master Agreement shall not constitute a default under this Power Purchase Agreement unless the event or circumstance giving rise to the default also constitutes a default under this Power Purchase Agreement.

6.02 Early Termination.

If an Event of Default shall have occurred and is continuing, the Party not in default (the "Non-Defaulting Party") shall have the right:

- (a) To designate, by Notice, a day, no earlier than twenty (20) days after the Notice is effective and no later than sixty (60) days after the Notice is effective, as an "Early Termination Date";
- (b) To immediately suspend performance under this Power Purchase Agreement; and
- (c) To pursue all remedies available at law or in equity against the Defaulting Party (including monetary damages), except to the extent that such remedies are limited by the terms of this Power Purchase Agreement.

6.03 Termination Payment.

As soon as practicable after an Early Termination Date is declared, the Non-Defaulting Party shall provide Notice to the Defaulting Party of the sum of all amounts owed by the Defaulting Party under this Power Purchase Agreement, less any amounts owed by the Non-Defaulting Party to the Defaulting Party (the "Termination Payment").

The Notice shall include a written statement setting forth, in reasonable detail, the calculation of such Termination Payment including the Forward Settlement Amount, together with appropriate supporting documentation.

If the Termination Payment is positive, the Defaulting Party shall pay such amount to the Non-Defaulting Party within ten (10) Business Days after the Notice is provided. If the Termination Payment is negative (i.e., the Non-Defaulting Party owes the Defaulting Party more than the Defaulting Party owes the Non-Defaulting Party), *then* the Non-Defaulting Party shall pay such amount to the Defaulting Party within thirty (30) days after the Notice is provided.

The Parties shall negotiate in good faith to resolve any disputes regarding the calculation of the Termination Payment. Any disputes which the Parties are unable to resolve through negotiation may be submitted for resolution through mediation and arbitration as provided in Article Twelve.

In the event that a Party is to receive a Termination Payment for an Early Termination Date (by determination of an Arbitrator or otherwise), such Termination Payment, once paid in full and credited to the account of the receiving Party, shall be the sole and exclusive remedy for the breach that was the basis of the designation of such Early Termination Date and for any obligation that does not survive termination; *provided that* nothing in this Section 6.03 shall limit either Party's right to enforce any obligations which survive termination of this Power Purchase Agreement.

*** *End of ARTICLE SIX* ***

The contents of this document are subject to restrictions on disclosure as set forth herein.

ARTICLE SEVEN. LIMITATIONS OF LIABILITIES

EXCEPT AS SET FORTH HEREIN, THERE ARE NO WARRANTIES BY EITHER PARTY UNDER THIS POWER PURCHASE AGREEMENT, INCLUDING ANY WARRANTY OF MERCHANTABILITY OR FITNESS FOR A PARTICULAR PURPOSE, AND ANY AND ALL IMPLIED WARRANTIES ARE DISCLAIMED. THE PARTIES CONFIRM THAT THE EXPRESS REMEDIES AND MEASURES OF DAMAGES PROVIDED IN THIS POWER PURCHASE AGREEMENT SATISFY THE ESSENTIAL PURPOSES HEREOF.

FOR BREACH OF ANY PROVISION FOR WHICH AN EXPRESS REMEDY OR MEASURE OF DAMAGES IS PROVIDED, SUCH EXPRESS REMEDY OR MEASURE OF DAMAGES SHALL BE THE SOLE AND EXCLUSIVE REMEDY, THE OBLIGOR'S LIABILITY SHALL BE LIMITED AS SET FORTH IN SUCH PROVISION AND ALL OTHER REMEDIES OR DAMAGES AT LAW OR IN EQUITY ARE WAIVED, UNLESS THE PROVISION IN QUESTION PROVIDES THAT THE EXPRESS REMEDIES ARE IN ADDITION TO OTHER REMEDIES THAT MAY BE AVAILABLE.

SUBJECT TO SECTION 10.16 (INJUNCTIVE RELIEF), IF NO REMEDY OR MEASURE OF DAMAGES IS EXPRESSLY PROVIDED HEREIN, THE OBLIGOR'S LIABILITY SHALL BE LIMITED TO DIRECT ACTUAL DAMAGES ONLY, SUCH DIRECT ACTUAL DAMAGES SHALL BE THE SOLE AND EXCLUSIVE REMEDY AND ALL OTHER REMEDIES OR DAMAGES AT LAW OR IN EQUITY ARE WAIVED.

UNLESS EXPRESSLY HEREIN PROVIDED, AND SUBJECT TO THE PROVISIONS OF SECTION 10.03 (INDEMNITY), NEITHER PARTY SHALL BE LIABLE FOR CONSEQUENTIAL, INCIDENTAL, PUNITIVE, EXEMPLARY OR INDIRECT DAMAGES, LOST PROFITS OR OTHER BUSINESS INTERRUPTION DAMAGES, BY STATUTE, IN TORT OR CONTRACT, UNDER ANY INDEMNITY PROVISION OR OTHERWISE.

IT IS THE INTENT OF THE PARTIES THAT THE LIMITATIONS HEREIN IMPOSED ON REMEDIES AND THE MEASURE OF DAMAGES BE WITHOUT REGARD TO THE CAUSE OR CAUSES RELATED THERETO, INCLUDING THE NEGLIGENCE OF ANY PARTY, WHETHER SUCH NEGLIGENCE BE SOLE, JOINT OR CONCURRENT, OR ACTIVE OR PASSIVE.

TO THE EXTENT ANY DAMAGES REQUIRED TO BE PAID HEREUNDER ARE LIQUIDATED, THE PARTIES ACKNOWLEDGE THAT THE DAMAGES ARE DIFFICULT OR IMPOSSIBLE TO DETERMINE, OR OTHERWISE OBTAINING AN ADEQUATE REMEDY IS INCONVENIENT AND THE DAMAGES CALCULATED HEREUNDER CONSTITUTE A REASONABLE APPROXIMATION OF THE HARM OR LOSS.

NOTHING IN THIS SECTION PREVENTS, OR IS INTENDED TO PREVENT SCE FROM PROCEEDING AGAINST OR EXERCISING ITS RIGHTS WITH RESPECT TO ANY SECURED INTERESTS IN COLLATERAL.

NOTWITHSTANDING ANYTHING TO THE CONTRARY SET FORTH HEREIN, THE VALUE, IF ANY, OF ANY PRODUCTION TAX CREDITS, DETERMINED ON AN AFTER-TAX BASIS, LOST DUE TO SCE'S DEFAULT, SHALL BE DEEMED DIRECT DAMAGES TO THE EXTENT LOST PRODUCTION TAX CREDITS ARE RECOVERABLE UNDER THIS POWER PURCHASE AGREEMENT.

NOTWITHSTANDING ANYTHING TO THE CONTRARY SET FORTH HEREIN, ISO CHARGES OR ISO SANCTIONS DIRECTLY ATTRIBUTABLE TO SCE'S FAILURE TO COMPLY WITH ITS OBLIGATIONS AS SELLER'S SCHEDULING COORDINATOR UNDER THIS POWER PURCHASE AGREEMENT SHALL BE DEEMED DIRECT DAMAGES.

NOTWITHSTANDING ANYTHING HEREIN TO THE CONTRARY AND WITHOUT LIMITING ANY RIGHT OF SCE TO TERMINATE THIS POWER PURCHASE AGREEMENT HEREUNDER, OR SCE'S RIGHTS PURSUANT TO SECTIONS 2.05(b) AND 3.19(b)(viii)(1), SELLER SHALL HAVE NO LIABILITY UNDER THIS POWER PURCHASE AGREEMENT UNTIL THE INITIAL OPERATION DATE.

**** End of ARTICLE SEVEN ****

ARTICLE EIGHT. CREDIT AND COLLATERAL REQUIREMENTS

8.01 Financial Information.

If requested by one Party, the other Party shall deliver:

- (a) Within one hundred twenty (120) days following the end of each fiscal year, a copy of its and its Guarantor's, if any, annual report containing audited consolidated financial statements for such fiscal year; *provided that* if Seller does not regularly prepare audited financial statements, it shall provide unaudited financial statements; and
- (b) Within sixty (60) days after the end of each of its first three fiscal quarters of each fiscal year, a copy of its and its Guarantor's, if any, quarterly report containing unaudited consolidated financial statements for such fiscal quarter; *provided that* if Seller does not regularly prepare quarterly reports, it shall not be required to do so.

In all cases the statements shall be for the most recent accounting period and prepared in accordance with generally accepted accounting principles; *provided that*, should any such statements not be available on a timely basis due to a delay in preparation or certification, such delay shall not be an Event of Default so long as the producing party diligently pursues the preparation, certification and delivery of the statements.

8.02 Performance Assurance.**(a) Posting Performance Assurance.**

On or before the commencement of the Facility Term, Seller shall post Performance Assurance in the Performance Assurance Amount with SCE.

The Performance Assurance in the Performance Assurance Amount shall be posted to SCE at all times during the Facility Term and thereafter until such time as Seller has satisfied all monetary obligations which survive any termination of this Power Purchase Agreement, not to exceed one year following the end of the Facility Term.

In lieu of Performance Assurance, SCE may accept a Guaranty Agreement, in accordance with Section 8.02(c) to satisfy the Seller's Performance Assurance obligation. Such Guaranty Agreement shall be for the Performance Assurance Amount (less any other Performance Assurance then in effect). At such time that Seller proposes to satisfy its Performance Assurance obligation by means of a Guaranty Agreement, Seller shall submit to SCE a Notice containing (i) financial statements and other information regarding the proposed Guarantor, (ii) the proposed Cross Default Amount and (iii) Credit Ratings and other relevant information provided by S&P or Moody's. SCE shall approve the

The contents of this document are subject to restrictions on disclosure as set forth herein.

Guarantor in accordance with Section 8.02(c) and the Cross Default Amount in its reasonable discretion.

(b) Letters of Credit.

Performance Assurance provided in the form of a Letter of Credit shall be subject to the following provisions:

- (i) Each Letter of Credit shall be maintained for the benefit of SCE;
- (ii) Seller shall:
 - (1) Renew or cause the renewal of each outstanding Letter of Credit on a timely basis as provided in the relevant Letter of Credit;
 - (2) If the bank that issued an outstanding Letter of Credit has indicated its intent not to renew such Letter of Credit, provide alternative Performance Assurance at least twenty (20) Business Days prior to the expiration of the outstanding Letter of Credit; and
 - (3) If the bank issuing a Letter of Credit fails to honor SCE's properly documented request to draw on an outstanding Letter of Credit, provide alternative Performance Assurance within three (3) Business Days after such refusal;
- (iii) Upon the occurrence of a Letter of Credit Default, Seller shall provide to SCE either a substitute Letter of Credit or alternative Performance Assurance, in each case on or before the third Business Day after the earlier of: (1) Notice from SCE of the occurrence thereof (or the tenth (10th) Business Day after Notice from SCE of the occurrence thereof if only Section (a) in the definition of "Letter of Credit Default" in Exhibit A applies), or (2) Seller's knowledge of the occurrence thereof. If Seller does not provide SCE either a substitute Letter of Credit or alternative Performance Assurance in such time period, SCE may draw on the existing Letter of Credit;
- (iv) Upon, or at any time after, the occurrence and continuation of an Event of Default by Seller, or if an Early Termination Date has occurred or been designated as a result of an Event of Default by Seller for which there exists any unsatisfied payment obligations, *then* SCE may draw on an amount that is equal to all amounts that are due and owing from any outstanding Letter of Credit upon submission to the bank issuing such Letter of Credit of one or more certificates specifying that such Event of Default or Early Termination Date has occurred and is

The contents of this document are subject to restrictions on disclosure as set forth herein.

continuing. Seller shall remain liable for any amounts due and owing to SCE and remaining unpaid after the application of the amounts so drawn by SCE.

Cash proceeds received by SCE from drawing upon the Letter of Credit shall be deemed Performance Assurance for Seller's obligations to SCE and SCE shall have the rights and remedies set forth in Section 8.03 with respect to such cash proceeds.

Notwithstanding SCE's receipt of cash proceeds of a drawing under the Letter of Credit, Seller shall remain liable for any:

- (1) Failure to provide sufficient Performance Assurance; or
 - (2) Any amounts owing to SCE and remaining unpaid after the application of the amounts so drawn by SCE.
- (v) In all cases, the costs and expenses of establishing, renewing, substituting, canceling, enforcing and increasing the amount of a Letter of Credit shall be borne by Seller; *provided that* SCE shall bear its own costs, including costs of outside counsel, associated with the establishment, maintenance, renewal, substitution, increase or cancellation of SCE's rights and obligations in connection with any Letter of Credit.
- (c) Guaranty Agreement.

If Seller's Performance Assurance obligation is satisfied by a Guaranty Agreement, it shall be in the form of Exhibit I executed by a Guarantor reasonably acceptable to SCE meeting the Credit Rating requirements for the Guarantor set forth immediately below. The Guarantor shall maintain a Credit Rating of at least:

- (i) "BBB-" from S&P and "Baa3" from Moody's, if it is rated by both S&P and Moody's; or
- (ii) "BBB-" from S&P or "Baa3" from Moody's if it is rated by either S&P or Moody's but not by both.

If at any time the Guarantor fails to maintain such Credit Ratings, the Seller shall provide to SCE Performance Assurance, or a replacement Guaranty Agreement from a Guarantor acceptable to SCE, within ten (10) Business Days.

8.03 First Priority Security Interest in Cash or Cash Equivalent Collateral.

To secure its obligations under this Power Purchase Agreement, and until released as provided herein, Seller hereby grants to SCE a present and continuing first-priority security interest ("Security Interest") in, and lien on (and right of setoff against), and assignment of any Performance Assurance, all cash collateral and cash equivalent collateral, if any, and any and all proceeds resulting therefrom or the liquidation thereof, whether now or hereafter held by, on behalf of, or for the benefit of SCE, and Seller agrees to take such action as SCE reasonably requires in order to perfect SCE's Security Interest in, and lien on (and right of setoff against), such collateral and any and all proceeds resulting therefrom or from the liquidation thereof.

Upon or any time after the occurrence or deemed occurrence and during the continuation of an Event of Default caused by Seller or an Early Termination Date caused by an Event of Default of Seller, SCE may do any one or more of the following:

- (a) Exercise any of its rights and remedies with respect to all Performance Assurance, including any such rights and remedies under law then in effect;
- (b) Draw on any outstanding Letter of Credit issued for its benefit; and
- (c) Liquidate all Performance Assurance then held by or for the benefit of SCE free from any claim or right of any nature whatsoever of Seller, including any equity or right of purchase or redemption by Seller.

SCE shall apply the proceeds of the collateral realized upon the exercise of any such rights or remedies to reduce Seller's obligations under this Power Purchase Agreement (Seller remaining liable for any amounts owing to SCE after such application), subject to SCE's obligation to return any surplus proceeds remaining after such obligations are satisfied in full.

8.04 Subordinated Security Interests and Mortgage.

- (a) Prior to the commencement of the Facility Term, as security for Seller's obligation to pay any Termination Payment, Seller or SCE, as the case may be, shall execute, deliver, file and record, as appropriate, separate agreements, documents, fixture filings, financing statements or instruments (the "Security Documents") under which Seller will grant to SCE, and subject to characterization as real or personal property in SCE's sole discretion, fully perfected security interest(s), or mortgage lien(s) in the Generating Facility, the Site and in any and all real and personal property rights, contractual rights, or other rights that Seller requires in order to construct or Operate the Generating Facility (collectively, the "Secured Interests"). These agreements shall be in the form of Exhibit T (for the conveyance of security interests in Seller's real property and related rights and interests) and in such other

The contents of this document are subject to restrictions on disclosure as set forth herein.

commercially reasonable form to be agreed for the other property, rights and interests of Seller as to which a security interest is to be conveyed to SCE as provided herein. Notwithstanding the foregoing, Seller shall not be required to provide a Secured Interest in the Site or in such real and personal property rights, contractual rights or other rights that Seller requires in order to construct or Operate the Generating Facility (or portions thereof) if such encumbrance is expressly prohibited or consent to encumber is required by Seller's underlying rights to the Site or is prohibited by any Applicable Law, and Seller shall provide evidence to SCE of such prohibition. Seller shall use good faith efforts (not including paying money or other financial concessions) to obtain permission to provide a Secured Interest for all or a portion of the Site or such other rights if such encumbrance is prohibited or consent to encumber is required (or in the case where any portion of the Site is owned by a Governmental Authority, permission to place on file with such Governmental Authority a notice of SCE's rights under this Power Purchase Agreement), provided that the obtaining of consent shall not be a condition to Seller's obligation to grant a security interest in property owned or controlled by an Affiliate of Seller. Seller expressly grants SCE the right to file and or record, as appropriate, such fixture filings, financing statements and other Security Documents in order to perfect its security interests in the Secured Interests; provided that SCE has executed a Subordination Agreement in favor of any Lender.

The Secured Interests shall, subject to SCE, Lender and Seller entering into a Collateral Assignment Agreement, be subordinate in right of payment, priority and remedies only to the interest of a first priority Lender in accordance with the terms of the Subordination Agreement; in no event shall the Secured Interests be subordinated to more than one Lender (or a single tranche of Lenders or multiple tranches that are *pari passu*) and one Tax Equity Provider (or single tranche of Tax Equity Providers or multiple tranches that are *pari passu*).

Seller shall provide, at its cost, to SCE a California Land Title Association standard coverage Lender's Policy of Title Insurance for the Site showing Seller, as the owner or lessee of the Site, the Secured Interests as a second priority lien (or a third priority lien in the case of subordination to a Lender and a Tax Equity Provider) against Seller's interests in the Site and listing as exceptions only Permitted Liens and such other items approved by SCE in its reasonable discretion. The requirement for a Lender's policy of title insurance shall apply to any Secured Interest encumbering real property interests delivered or to be delivered to SCE under the terms of this Power Purchase Agreement.

The Secured Interests shall not include the pledge, assignment, security or other interest in (i) the ownership interest in Seller, and (ii) any cash, deposit

The contents of this document are subject to restrictions on disclosure as set forth herein.

accounts, instruments, insurance proceeds (other than insurance proceeds from policies covering the real property to the extent of SCE's insured interest therein) and cash equivalents (except to the extent specifically pledged or provided as Performance Assurance). Nothing set forth in this Power Purchase Agreement shall be deemed to prohibit or restrict Seller's rights to encumber its interest in the Site, the Generating Facility or any personal property or contract rights relating thereto, subject to the provisions of Sections 8.05, 10.04 and 10.05 hereof. If Seller enters into any sublease with respect to the Site, such sublease shall include commercially reasonable lender protection provisions. SCE agrees make commercially reasonable efforts (not including paying money or other financial concessions) to cooperate in connection with any such financing secured by lien(s) against the Site, and agrees to execute commercially reasonable estoppel certificates, Subordination Agreements and other documents reasonably requested by a Lender in connection with any such financing, subject to SCE's reasonable approval.

- (b) The Parties shall confirm, define, and perfect the Secured Interests by executing, delivering, filing and recording (which filing and recording costs shall be and recording, at the expense of Seller), the Security Documents.

The Security Documents shall contain financial and operating covenants intended to preserve and maintain the value of the Security Interests and substantially similar to those in favor of Lender in the Lender's security documents, subject in each case to the terms of the Subordination Agreement.

In addition, Seller agrees to file and expressly grants SCE the right to file or, in the case of a fixture filing record, such Uniform Commercial Code financing statements and to take such further action and execute such further instruments as shall reasonably be required by SCE to confirm and continue the validity, priority, and perfection of the Secured Interests.

The granting of the Secured Interests shall not be to the exclusion of, nor be construed to limit the amount of any further claims, causes of action or other rights accruing to SCE by reason of any breach or default by Seller under this Power Purchase Agreement or the termination of this Power Purchase Agreement prior to the expiration of the Facility Term.

The Secured Interests shall be discharged and released, and SCE shall take any steps reasonably required by Seller to effect and record such discharge and release, upon the expiration of the Facility Term or the termination of this Power Purchase Agreement and satisfaction by Seller of all of its obligations hereunder that are secured by the Secured Interests.

Seller shall pay all filing and recording fees or costs or trustee's fees or costs related to such discharge and release or reconveyance of the Secured Interests.

The contents of this document are subject to restrictions on disclosure as set forth herein.

-
- (c) If SCE acts to obtain title to the Generating Facility pursuant to the interests provided by Seller pursuant to Section 8.04(a), Seller shall take all steps necessary to transfer all permits and licenses necessary to Operate the Generating Facility to SCE, and shall diligently prosecute and cooperate in such transfers, in each case subject to the terms of the Subordination Agreement.

8.05 Credit and Collateral Covenants.

- (a) Seller shall, from time to time as requested by SCE, execute, acknowledge, record, register, deliver and file all such notices, statements, instruments and other documents as may be necessary or advisable to render fully valid and enforceable under all applicable laws the Security Documents and the rights, liens and priorities of SCE with respect to the Security Interest and the Secured Interests provided for herein and therein;
- (b) Reserved;
- (c) Reserved;
- (d) Except for liens permitted under the Security Documents and liens for the benefit of Lender, Seller shall not create, incur, assume or suffer to be created by it or any subcontractor, employee, laborer, materialman, other supplier of goods or services or any other person, any lien on Seller's interest (or any part thereof) in this Power Purchase Agreement, the Site or the Generating Facility. Seller promptly shall pay or discharge, or shall cause its contractors to promptly pay and discharge, and discharge of record, any such lien for labor, materials, supplies or other obligations upon Seller's interest in the Site, the Generating Facility, or any part thereof or interest therein, unless Seller is disputing any such lien in good faith and only for so long as it does not create an imminent risk of a sale or transfer of the Generating Facility or a material part thereof. Seller shall promptly notify SCE of any attachment or imposition of any lien for which Seller has an obligation to defend under the Security Documents;
- (e) Reserved;
- (f) Seller shall not hold any material assets, become liable for any material obligations or engage in any material business activities other than the development, construction and operation of the Generating Facility and activities incidental thereto;
- (g) Seller shall not own, form or acquire, or otherwise conduct any of its activities through, any direct or indirect subsidiary; and
- (h) During any period during which a Seller is a Defaulting Party, Seller shall:

The contents of this document are subject to restrictions on disclosure as set forth herein.

-
- (i) Not declare or pay any dividend, or make any other distribution or payment, on account of any equity interest in Seller, except for distributions made directly or indirectly to Tax Equity Providers; or
 - (ii) Not make any distribution or payment to any Affiliate of Seller, except for commercially reasonable payments due under any Lease or and in connection with services rendered under any operation, maintenance, management, service, administration and similar agreements related to the Generating Facility in each case made in the ordinary course of business.

8.06 Waivers.

SELLER SHALL NOT AT ANY TIME INSIST UPON, PLEAD, CLAIM OR TAKE THE BENEFIT OR ADVANTAGE OF ANY LAW NOW OR HEREAFTER IN FORCE PROVIDING FOR ANY APPRAISEMENT, VALUATION, STAY OF EXECUTION, EXEMPTION, EXTENSION OR REDEMPTION, OR REQUIRING FORECLOSURE OF ANY RIGHTS GRANTED TO SCE BY SELLER UNDER ANY DEED OF TRUST BEFORE EXERCISING ANY OTHER REMEDY GRANTED HEREUNDER.

*** *End of ARTICLE EIGHT* ***

ARTICLE NINE. GOVERNMENTAL CHARGES

9.01 Cooperation to Minimize Tax Liabilities.

Each Party shall use reasonable efforts to implement the provisions of and to administer this Power Purchase Agreement in accordance with the intent of the Parties to minimize all taxes, so long as neither Party is materially adversely affected by such efforts.

9.02 Governmental Charges.

Seller shall pay or cause to be paid all taxes imposed by any Governmental Authority ("Governmental Charges") on or with respect to the Delivered Amounts (and any contract associated with the Delivered Amounts) and the Scheduled Amounts arising prior to and at the Delivery Point, including, but not limited to, ad valorem taxes and other taxes attributable to the Generating Facility, land, land rights or interests in land for the Generating Facility.

SCE shall pay or cause to be paid all Governmental Charges on or with respect to the Scheduled Amounts or Delivered Amounts, as applicable, from the Delivery Point. In the event Seller is required by law or regulation to remit or pay Governmental Charges which are SCE's responsibility hereunder, SCE shall promptly reimburse Seller for such Governmental Charges.

If SCE is required by law or regulation to remit or pay Governmental Charges which are Seller's responsibility hereunder, SCE may deduct such amounts from payments to Seller made pursuant to Article Four.

If SCE elects not to deduct such amounts from Seller's payments, Seller shall promptly reimburse SCE for such amounts upon request. Nothing shall obligate or cause a Party to pay or be liable to pay any Governmental Charges for which it is exempt under the law.

9.03 Providing Information to Taxing Authorities.

Seller or SCE, as necessary, shall provide information concerning the Generating Facility to any requesting taxing authority.

**** End of ARTICLE NINE ****

The contents of this document are subject to restrictions on disclosure as set forth herein.

ARTICLE TEN. MISCELLANEOUS**10.01 Representations, Warranties and Covenants.**

On the Power Purchase Agreement Effective Date, each Party represents, warrants and covenants to the other Party that:

- (a) It is duly organized, validly existing and in good standing under the laws of the jurisdiction of its formation;
- (b) Except for all Permits in the case of Seller, it has or will timely acquire all regulatory authorizations necessary for it to legally perform its obligations under this Power Purchase Agreement;
- (c) The execution, delivery and performance of this Power Purchase Agreement are within its powers, have been duly authorized by all necessary action and do not violate any of the terms and conditions in its governing documents, any contracts to which it is a party or any law, rule, regulation, order or the like applicable to it;
- (d) This Power Purchase Agreement constitutes a legally valid and binding obligation enforceable against it in accordance with its terms, subject to any Equitable Defenses;
- (e) There is not pending, or to its knowledge, threatened against it or any of its Affiliates, any legal proceedings that could materially adversely affect its ability to perform under this Power Purchase Agreement;
- (f) No Event of Default with respect to it has occurred and is continuing and no such event or circumstance would occur as a result of its entering into or performing its obligations under this Power Purchase Agreement;
- (g) It is acting for its own account and its decision to enter into this Power Purchase Agreement is based upon its own judgment, not in reliance upon the advice or recommendations of the other Party and it is capable of assessing the merits of and understanding, and understands and accepts the terms, conditions and risks of this Power Purchase Agreement;

It has not relied upon any promises, representations, statements or information of any kind whatsoever that are not contained in this Power Purchase Agreement in deciding to enter into this Power Purchase Agreement; and
- (h) It has entered into this Power Purchase Agreement in connection with the conduct of its business and it has the capacity or ability to make or take delivery of the Product as contemplated in this Power Purchase Agreement.

The contents of this document are subject to restrictions on disclosure as set forth herein.

10.02 Additional Representations, Warranties and Covenants.

Seller hereby represents, warrants and covenants to SCE that throughout the Facility Term, except as otherwise permitted under this Power Purchase Agreement:

- (a) It will own and Operate the Generating Facility;
- (b) It will deliver to SCE the Product free and clear of all liens, security interests, claims and encumbrances or any interest therein or thereto by any Person;
- (c) It will hold the rights to all Green Attributes, Capacity Attributes and Resource Adequacy Benefits, which it has conveyed and has committed to convey to SCE hereunder; and
- (d) It has all Permits necessary to Operate the Generating Facility and to deliver electric energy from the Generating Facility to the Delivery Point and shall maintain and remain in material compliance with such Permits.

10.03 Indemnity.

- (a) Each Party as indemnitor shall defend, save harmless and indemnify the other Party and the directors, officers, employees, and agents of such other Party against and from any and all loss, liability, damage, claim, cost, charge, demand, or expense (including any direct, indirect, or consequential loss, liability, damage, claim, cost, charge, demand, or expense, including attorneys' fees) for injury or death to persons, including employees of either Party, and physical damage to property including property of either Party, arising out or in connection with the gross negligence or willful misconduct of the indemnitor relating to its obligations under this Power Purchase Agreement.

This indemnity shall apply notwithstanding the active or passive negligence of the indemnitee.

However, neither Party shall be indemnified hereunder for its loss, liability, damage, claim, cost, charge, demand or expense resulting from its gross negligence or willful misconduct.

- (b) Each Party (the "Indemnifying Party") releases and shall defend, save harmless and indemnify the other Party from any and all loss, liability, damage, claim, cost, charge, demand or expense arising out of or in connection with any breach made by the Indemnifying Party of its representations and warranties in Sections 10.01 and 10.02.

- (c) The provisions of this Section 10.03 shall not be construed to relieve any insurer of its obligations to pay any insurance claims in accordance with the provisions of any valid insurance policy.
- (d) Except as otherwise provided in Sections 10.03(a) and 10.03(f), neither Party shall be liable to the other Party for consequential damages incurred by such other Party.
- (e) Notwithstanding anything to the contrary in this Power Purchase Agreement, if Seller fails to comply with the provisions of Section 10.11, Seller shall, at its own cost, defend, save harmless and indemnify SCE, its directors, officers, employees, and agents, assigns, and successors in interest, from and against any and all loss, liability, damage, claim, cost, charge, demand, or expense of any kind or nature (including any direct, indirect, or consequential loss, damage, claim, cost, charge, demand, or expense, including attorneys' fees and other costs of litigation), resulting from injury or death to any person or damage to any property, including the personnel or property of SCE, to the extent that SCE would have been protected had Seller complied with all of the provisions of Section 10.11.

The inclusion of this Section 10.03(e) is not intended to create any express or implied right in Seller to elect not to provide the insurance required under Section 10.11.

- (f) Each Party shall indemnify, defend and hold harmless the other Party against any Governmental Charges for which such Party is responsible under Article Nine.
- (g) All indemnity rights shall survive the termination of this Power Purchase Agreement for twelve (12) months.

10.04 Assignment.

Except as provided in Sections 10.05, neither Party shall assign this Power Purchase Agreement or its rights hereunder without the prior written consent of the other Party, which consent shall not be unreasonably withheld.

10.05 Consent to Collateral Assignment.

Subject to the provisions of this Section 10.05, Seller shall have the right to assign this Power Purchase Agreement as collateral for any financing or refinancing of the Generating Facility.

In connection with, and as a condition to, any financing or refinancing of the Generating Facility by Seller, SCE shall in good faith work with Seller and Lender to

agree upon a consent to collateral assignment of this Power Purchase Agreement (“Collateral Assignment Agreement”).

The Collateral Assignment Agreement shall be in form and substance reasonably agreed to by SCE, Seller and Lender, and shall include, among other things, the following provisions (together with such other commercially reasonable provisions required by any Lender that are reasonably acceptable to SCE):

- (a) SCE shall give to the person(s) specified by Lender in the Collateral Assignment Agreement, simultaneously with the Notice to Seller and prior to exercising its right to terminate this Power Purchase Agreement, written Notice of any event or occurrence known to SCE which would, if not cured with the applicable cure period as specified in Section 6.01, constitute an Event of Default (an “Incipient Event of Default”);
- (b) Lender shall have the right to cure an Incipient Event of Default or an Event of Default by Seller in accordance with the same provisions of this Power Purchase Agreement as apply to Seller;
- (c) Following an Event of Default by Seller under this Power Purchase Agreement, SCE may require Seller (although Lender may, but shall have no obligation, subject to Section 10.05(g), to perform) to provide to SCE a report concerning:
 - (i) The status of efforts by Seller or Lender to develop a plan to cure the Event of Default;
 - (ii) Impediments to the cure plan or its development;
 - (iii) If a cure plan has been adopted, the status of the cure plan’s implementation (including any modifications to the plan as well as the expected timeframe within which any cure is expected to be implemented); and
 - (iv) Any other information which SCE may reasonably require related to the development, implementation and timetable of the cure plan.

Seller or Lender shall provide the report to SCE within ten (10) Business Days of Notice from SCE requesting the report. SCE shall have no further right to require the report with respect to a particular Event of Default after that Event of Default has been cured;

- (d) Lender shall have the right to cure an Incipient Event of Default or an Event of Default on behalf of Seller, only if Lender sends a written notice to SCE prior to the end of any cure period indicating Lender’s intention to cure. Lender may remedy or cure the Incipient Event of Default or Event of Default

The contents of this document are subject to restrictions on disclosure as set forth herein.

within the cure period under this Power Purchase Agreement. Such cure period for Lender shall be extended for each day SCE does not provide the Notice to Lender referred to in Section 10.05(a). In addition, such cure period may, in SCE's reasonable discretion, be extended by no more than an additional one hundred eighty (180) days. If possession of the Generating Facility is necessary to cure such Incipient Event of Default or Event of Default, Lender has commenced foreclosure proceedings within sixty (60) days after receipt of such Notice from SCE, and Lender is making diligent and consistent efforts to complete such foreclosure, take possession of the Generating Facility and promptly cure the Incipient Event of Default or Event of Default, Lender or its designee(s) or assignee(s) will be allowed a reasonable period of time to complete such foreclosure proceedings, take possession of the Generating Facility and cure such Incipient Event of Default or Event of Default, not to exceed one hundred eighty (180) days after Lender's commencement of foreclosure. Additionally, if Lender is prohibited from curing any Incipient Event of Default or Event of Default by any process, stay or injunction issued by an Governmental Authority or pursuant to any bankruptcy, insolvency or similar proceedings, then the time period for curing such Incipient Event of Default or Event of Default shall be extended for the period of the prohibition provided that Lender is exercising reasonable diligence in having such process, stay or injunction removed;

- (e) Lender shall have the right to consent prior to any termination of this Power Purchase Agreement which does not arise out of an Event of Default or the end of the Facility Term;
- (f) Lender shall receive prior Notice of and the right to approve material amendments to this Power Purchase Agreement, which approval shall not be unreasonably withheld, delayed or conditioned;
- (g) In the event Lender, directly or indirectly, takes title to the Generating Facility (including title by foreclosure or deed in lieu of foreclosure), the entity taking title to the Generating Facility shall assume all of Seller's obligations arising under this Power Purchase Agreement and all related agreements (subject to such limits on liability as are mutually agreed to by Seller, SCE and Lender as set forth in the Collateral Assignment Agreement); *provided that*, Lender (or such entity) shall have no liability for any monetary obligations of Seller under this Power Purchase Agreement which are due and owing to SCE as of the assumption date (but this provision shall not be interpreted to limit SCE's rights to proceed against Seller as a result of an Event of Default) and Lender's (or such entity's) liability to SCE after such assumption shall be limited to its interest in the Generating Facility; *provided, however*, that prior to such assumption, if SCE advises Lender (or such entity) that SCE will require that Lender (or such entity) cure (or cause to be cured) one or more monetary or non-monetary Incipient Event of Default or Event of Default

The contents of this document are subject to restrictions on disclosure as set forth herein.

existing as of the date such entity takes title in order to avoid the exercise by SCE (in its sole discretion) of SCE's right to terminate this Power Purchase Agreement in respect of such Incipient Event of Default or Event of Default, *then* Lender (or such entity) at its option, and in its sole discretion, may elect to either:

- (i) Cause such Incipient Event(s) of Default or Event(s) of Default to be cured; or
 - (ii) Not assume this Power Purchase Agreement.
- (h) If Lender has assumed this Power Purchase Agreement as provided in Section 10.05(g) and elects to sell or transfer the Generating Facility (after Lender directly or indirectly, takes title to the Generating Facility), or sale of the Generating Facility occurs through the actions of Lender or an agent of or representative of Lender (excluding any foreclosure sale where a third party other than Lender, Seller, an Affiliate of Lender or an Affiliate of Seller is the buyer), *then* Lender must cause the transferee or buyer to assume all of Seller's obligations arising under this Power Purchase Agreement and all related agreements as a condition of the sale or transfer excluding, however, a foreclosure (unless the transferee or buyer is Lender, Seller, an Affiliate of Lender or an Affiliate of Seller). Lender shall be released from all further obligations under the Power Purchase Agreement and all related documents following such assumption.
- Such sale or transfer (excluding however, a foreclosure) may be made only to a Permitted Transferee or to an entity with financial qualifications and operating experience equivalent to Seller that is reasonably acceptable to SCE;
- (i) If this Power Purchase Agreement is rejected in Seller's Bankruptcy or otherwise terminated in connection therewith and if Lender or its representative or designee, directly or indirectly, takes title to the Generating Facility, then, at the request of either SCE or Lender, SCE and Lender (or its designee or representative) shall promptly enter into a new agreement having substantially the same terms as this Power Purchase Agreement for the term that would have been remaining under this Power Purchase Agreement, provided that Lender's (or its designee's or representative's) liability under such new agreement shall be limited to its interest in the Generating Facility and neither Lender (or its designee or representative) nor SCE shall have any personal liability to the other for any amounts owing and neither SCE nor Lender (or its designee or representative) shall have any obligation to cure any defaults under the original Power Purchase Agreement that was rejected in, or otherwise terminated in connection with Seller's Bankruptcy.

10.06 Abandonment.

The contents of this document are subject to restrictions on disclosure as set forth herein.

Except as provided under Section 10.05(h), Seller shall not relinquish its possession and control of the Generating Facility without the prior written consent of SCE.

For purposes of this Section 10.06, Seller shall have been deemed to relinquish possession of the Generating Facility if Seller has ceased production and delivery of the Product, and such cessation is not a result of an event of Force Majeure, for a consecutive thirty (30) day period and Seller is not attempting to restore its ability to produce Product.

10.07 Governing Law.

THIS AGREEMENT AND THE RIGHTS AND DUTIES OF THE PARTIES HEREUNDER SHALL BE GOVERNED BY AND CONSTRUED, ENFORCED AND PERFORMED IN ACCORDANCE WITH THE LAWS OF THE STATE OF CALIFORNIA, WITHOUT REGARD TO PRINCIPLES OF CONFLICTS OF LAW. TO THE EXTENT ENFORCEABLE AT SUCH TIME, EACH PARTY WAIVES ITS RESPECTIVE RIGHT TO ANY JURY TRIAL WITH RESPECT TO ANY LITIGATION ARISING UNDER OR IN CONNECTION WITH THIS AGREEMENT.

10.08 Notices.

All notices, requests, statements or payments shall be made as specified in Exhibit C.

Notices (other than scheduling requests) shall, unless otherwise specified herein, be in writing and may be delivered by hand delivery, first class United States mail, overnight courier service or facsimile.

Notice provided in accordance with this Section 10.08 shall be deemed given as follows:

- (a) Notice by facsimile or hand delivery shall be deemed given at the close of business on the day actually received, if received during business hours on a Business Day, and otherwise shall be deemed given at the close of business on the next Business Day;
- (b) Notice by overnight mail or courier service shall be deemed given on the next Business Day after it was sent out; and
- (c) Notice by first class United States mail shall be deemed given two (2) Business Days after the postmarked date.

Notices shall be effective on the date deemed given, unless a different date for the Notice to go into effect is stated in another section of this Power Purchase Agreement.

The contents of this document are subject to restrictions on disclosure as set forth herein.

A Party may change its designated representatives, addresses and other contact information by providing notice of same in accordance herewith.

All notices, requests, statements or payments for this Generating Facility must reference the QFID number set forth on the title page to this Power Purchase Agreement.

10.09 General.

- (a) This Power Purchase Agreement constitutes the entire agreement between the Parties relating to its subject matter.
- (b) This Power Purchase Agreement shall be considered for all purposes as prepared through the joint efforts of the Parties and shall not be construed against one Party or the other as a result of the preparation, substitution, submission or other event of negotiation, drafting or execution hereof.
- (c) Except to the extent provided for herein, no amendment or modification to this Power Purchase Agreement shall be enforceable unless reduced to a writing signed by all Parties.
- (d) This Power Purchase Agreement shall not impart any rights enforceable by any third party (other than a permitted successor or assignee bound to this Power Purchase Agreement).
- (e) Waiver by a Party of any default by the other Party shall not be construed as a waiver of any other default.
- (f) The term "including" when used in this Power Purchase Agreement shall be by way of example only and shall not be considered in any way to be in limitation.
- (g) The word "or" when used in this Power Purchase Agreement shall include the meaning "and/or" unless the context unambiguously dictates otherwise.
- (h) The headings used herein are for convenience and reference purposes only. Words having well-known technical or industry meanings shall have such meanings unless otherwise specifically defined herein.
- (i) Where days are not specifically designated as Business Days, they are calendar days.
- (j) This Power Purchase Agreement shall be binding on each Party's successors and permitted assigns.
- (k) No provision of this Power Purchase Agreement is intended to contradict or supersede any applicable agreement covering transmission, distribution,

The contents of this document are subject to restrictions on disclosure as set forth herein.

metering, scheduling or interconnection between the Parties, the ISO Tariff or the requirements of PIRP, if Seller is a Participating Intermittent Resource. In the event of an apparent contradiction between this Power Purchase Agreement and any such other agreement in respect of transmission, distribution, metering, scheduling or interconnection services, the ISO Tariff or the requirements of PIRP, if Seller is a Participating Intermittent Resource, the other agreement or ISO provision shall control. No default under any other agreement covering transmission, distribution, metering, scheduling or interconnection between the Parties shall constitute a default hereunder.

- (l) Except where expressly provided otherwise herein, whenever this Power Purchase Agreement specifically refers to any law, tariff, government department or agency, regional reliability council, Transmission Provider, or credit rating agency, the Parties hereby agree that the reference shall also refer to any successor to such law, tariff or organization.
- (m) SCE has assigned a "QFID" number to this Power Purchase Agreement for tracking purposes only and is not requiring that the Generating Facility be a "qualifying facility" under state or federal law.
- (n) SCE's obligation to take and pay for electric energy produced by the Generating Facility together with Green Attributes and Capacity Attributes associated therewith, shall not be affected by any change to or elimination of the RPS Legislation or any Resource Adequacy Requirements.
- (o) The Parties acknowledge and agree that this Power Purchase Agreement and the transactions contemplated by this Power Purchase Agreement constitute a "forward contract" within the meaning of the United States Bankruptcy Code and that SCE and Seller are each "forward contract merchants" within the meaning of the United States Bankruptcy Code.

10.10 Confidentiality.

- (a) Terms and Conditions of this Power Purchase Agreement.
Neither Party shall disclose Confidential Information to a third party, other than:
 - (i) To such Party's employees, Lenders, counsel, accountants, advisors, Affiliates, investors, in each case who have a need to know such information and have agreed to keep such terms confidential;
 - (ii) To potential investors in any Terra-Gen Affiliate holding a direct or indirect interest in Developer or any SPE or other potential investors in Seller, with the consent of SCE, which consent shall not be unreasonably withheld, delayed or conditioned; *provided, however,* that disclosure to potential investors concerning an investment of more

The contents of this document are subject to restrictions on disclosure as set forth herein.

than twenty million dollars (\$20,000,000) in any Terra-Gen Affiliate holding a direct or indirect interest in Developer or any SPE shall not require such consent of SCE, and *provided further that*, in each case such Person has a need to know such information and has agreed to keep such terms confidential;

- (iii) To potential Lenders with the consent of SCE, which consent shall not be unreasonably withheld, delayed or conditioned; *provided, however*, that disclosure (A) of cash flow and other financial projections to any potential Lender in connection with a potential loan or tax equity investment or (B) to potential Lenders with whom Seller has negotiated (but not necessarily executed) a term sheet or other similar written mutual understanding, shall not require such consent of SCE, and *provided further that*, in each case such potential Lender has a need to know such information and has agreed to keep such terms confidential;
- (iv) To SCE's Procurement Review Group, as defined in CPUC Decision 02-08-071, subject to any confidentiality agreements or laws, regulations or regulatory decisions concerning confidentiality which are applicable to SCE's Procurement Review Group;
- (v) To the CPUC under seal for purposes of review subject to the disclosing Party ("Disclosing Party") making reasonable efforts to obtain confidentiality protection from the CPUC under Section 583 of the California Public Utilities Code or other statute, order or rule offering comparable confidentiality protection;
- (vi) In order to comply with any Applicable Law, Australian law, or any exchange, control area or ISO rule, or order issued by a court or entity with competent jurisdiction over the Disclosing Party, other than to those entities set forth in Section 10.10(a)(vii);
- (vii) In order to comply with any applicable regulation, rule, or order of the CPUC, CEC, FERC, any court, administrative agency, legislative body or other tribunal, or any discovery or data request of a party to any proceeding pending before any of the foregoing;
- (viii) To any governmental body, the CPUC, the ISO or any local control area or regional authority having jurisdiction in order to support SCE's RAR showings, if applicable; provided, that SCE shall, to the extent reasonable, use reasonable efforts to limit the ability of any such applicable governmental body, ISO, local control area or regional authority to further disclose such information;

The contents of this document are subject to restrictions on disclosure as set forth herein.

-
- (ix) To Seller's SC, only in respect to the transfer of Resource Adequacy Benefits under this Power Purchase Agreement, in order for such SC to timely submit accurate Supply Plans; *provided that*, Seller shall, to the extent reasonable, use reasonable efforts to limit the ability of Seller's SC to further disclose such information;
 - (x) As may reasonably be required to participate in any auction, market or other process pertaining to the allocation of priorities or rights related to the transmission of electrical energy sold or to be sold to SCE hereunder;
 - (xi) To representatives of a Party's credit ratings agencies:
 - (1) Who have a need to review the terms and conditions of this Agreement for the purpose of assisting the Party in evaluating this Power Purchase Agreement for credit rating purposes; or
 - (2) With respect to the potential impact of this Power Purchase Agreement on the Party's financial reporting obligations;
 - (xii) Disclosure of terms specified in and pursuant to Section 10.10(b);
 - (xiii) In connection with discovery requests or orders pertaining to the non-public terms of this Power Purchase Agreement as referenced in Section 10.10(a)(vii) ("Disclosure Order") each Party shall, to the extent practicable, use reasonable efforts to:
 - (1) Notify the other Party prior to disclosing the confidential information; and
 - (2) Prevent or limit such disclosure.After using such reasonable efforts, the Disclosing Party shall not be:
 - (3) Prohibited from complying with a Disclosure Order; or
 - (4) Liable to the other Party for monetary or other damages incurred in connection with the disclosure of the confidential information.Except as provided in the preceding sentence, the Parties shall be entitled to all remedies available at law or in equity to enforce, or seek relief in connection with this confidentiality obligation.
 - (xiv) The recording of the Security Documents pursuant to Section 8.04 or the Notice of Right of First Offer pursuant to Section 2.05(b)(i)(1).

The contents of this document are subject to restrictions on disclosure as set forth herein.

-
- (xiii) The disclosure of the Right of First Offer and the relevant provisions Section 2.05(b) to potential third party purchasers as described in Section 2.05(b).

(b) RPS Confidentiality.

Notwithstanding Section 10.10(a), either Party shall be permitted to disclose the following terms with respect to this Power Purchase Agreement:

- (i) Party names;
- (ii) ERR type;
- (iii) Facility Term;
- (iv) Generating Facility location;
- (v) Expected deliveries;
- (vi) Delivery Point;
- (vii) Online date; and
- (viii) Nameplate Contract Capacity.

10.11 Insurance.

- (a) Throughout the Facility Term, Seller shall obtain and maintain in force as hereinafter provided commercial general liability insurance, including contractual liability coverage, with a combined single limit of not less than two million dollars (\$2,000,000) for each occurrence.

The insurance carrier or carriers shall have an AM Best rating of at least "A-" with a size rating of at least "VII" and the form of policy shall meet Prudent Electrical Practices.

- (b) Before the Initial Operation Date, as provided in Section 2.03(b), Seller shall:
 - (i) Furnish a certificate of insurance to SCE, which certificate shall provide that such insurance shall not be terminated nor expire except on thirty (30) calendar days' prior written notice to SCE;
 - (ii) Furnish to SCE an additional insured endorsement with respect to such insurance in substantially the following form:

“In consideration of the premium charged, SCE is named as additional insured with respect to all liabilities arising out of Seller’s use and ownership of Seller’s Generating Facility.

The inclusion of more than one insured under this policy shall not operate to impair the rights of one insured against another insured and the coverages afforded by this policy will apply as though separate policies had been issued to each insured.

The inclusion of more than one insured will not, however, operate to increase the limit of the carrier’s liability.

SCE will not, by reason of its inclusion under this policy, incur liability to the insurance carrier for payment of premium for this policy.

Any other insurance carried by SCE which may be applicable shall be deemed excess insurance and Seller’s insurance primary for all purposes despite any conflicting provisions in Seller’s policy to the contrary.”

10.12 Nondedication.

Notwithstanding any other provisions of this Power Purchase Agreement, neither Party dedicates any of the rights that are or may be derived from this Power Purchase Agreement or any part of its facilities involved in the performance of this Power Purchase Agreement to the public or to the service provided under the Power Purchase Agreement, and such service shall cease upon termination of the Power Purchase Agreement.

10.13 Mobile Sierra.

Notwithstanding any provision of this Power Purchase Agreement, neither Party shall seek, nor shall they support any third party in seeking, to prospectively or retroactively revise the rates, terms and/or conditions of service of this Power Purchase Agreement through application or complaint to FERC pursuant to the provisions of Section 205, 206 or 306 of the Federal Power Act, or any other provisions of the Federal Power Act, absent prior written agreement of the Parties.

Further, absent the prior agreement in writing by both Parties, the standard of review for changes to the rates, terms or conditions of service of this Power Purchase Agreement proposed by a Party, a non-Party or the FERC acting *sua sponte* shall be the “public interest” standard of review set forth in *United Gas Pipe Line Co. v. Mobile Gas Service Corp.*, 350 US 332 (1956) and *Federal Power Commission v. Sierra Pacific Power Co.*, 350 US 348 (1956).

10.14 Simple Interest Payments.

Except as specifically provided in this Power Purchase Agreement, any outstanding and past due amounts owing and unpaid by either Party under the terms of this Power Purchase Agreement, shall receive a Simple Interest Payment, calculated using the Interest Rate, for the number of days between the date due and the date paid.

10.15 Payments.

Payments to be made under this Power Purchase Agreement shall be made by wire transfer.

10.16 Injunctive Relief.

Notwithstanding Article Twelve or anything in this Power Purchase Agreement to the contrary, the Parties acknowledge and agree that irreparable damage would occur in the event that any of the provisions of Sections 2.05(b), 3.01(a), (b) and (f), 3.02, 3.07 or 10.10 were not performed in accordance with the terms thereof, that money damages would not be a sufficient remedy for any breach of such section, and that the Parties shall be entitled, without the requirement of posting a bond or other security, to specific performance and injunctive or other equitable relief as a remedy for any such breach. Such remedy shall not be deemed to be the exclusive remedy for breach of this Power Purchase Agreement but shall be in addition to all other remedies available at law or equity to the Parties.

10.17 Further Actions.

Each Party shall take such further actions, as may be reasonably requested by the other Party that are necessary to effectuate the intention of the terms of this Power Purchase Agreement.

10.18 Seller, and, if applicable, its successors, represents and warrants that throughout the Delivery Term of this Agreement that: (i) the Project qualifies and is certified by the CEC as an Eligible Renewable Energy Resource ("ERR") as such term is defined in Public Utilities Code Section 399.12 or Section 399.16; and (ii) the Project's output delivered to Buyer qualifies under the requirements of the California Renewables Portfolio Standard. To the extent a change in law occurs after execution of this Agreement that causes this representation and warranty to be materially false or misleading, it shall not be an Event of Default if Seller has used commercially reasonable efforts to comply with such change in law.

The term "commercially reasonable efforts" as used in Section 10.18 shall not require Seller to incur out of pocket costs in excess of \$25,000 in any year in order to obtain and maintain CEC Certification and Verification under the then-current Applicable Laws.

***** End of ARTICLE TEN *****

The contents of this document are subject to restrictions on disclosure as set forth herein.

ARTICLE ELEVEN. CHANGE IN ELECTRIC MARKET DESIGN

11.01 Changes Rendering the Agreement Incapable of Performance.

- (a) If a Change in ISO Tariff renders this Power Purchase Agreement or any terms herein incapable of being performed or administered, or results, or could reasonably be forecasted to result, in an ISO Change Cost Payment as defined herein for any Facility Term Year, *then* either Party, on Notice, may request the other Party to enter into negotiations to make the minimum changes to this Power Purchase Agreement necessary to make this Power Purchase Agreement capable of being performed and administered or to minimize ISO Change Cost Payments, while attempting to preserve to the maximum extent possible the benefits, burdens and obligations set forth in this Power Purchase Agreement as of the Master Agreement Effective Date.
- (b) Upon receipt of a Notice requesting negotiations, the Parties shall negotiate in good faith.
- (c) If the Parties are unable, within sixty (60) days of the sending of the Notice requesting negotiations, either to agree upon changes to this Power Purchase Agreement or to resolve issues relating to changes to this Power Purchase Agreement, *then* either Party may submit issues pertaining to changes to this Power Purchase Agreement to mediation and arbitration as provided in Article Twelve.
- (d) A change in cost shall not in itself be deemed to render this Power Purchase Agreement or any terms therein incapable of being performed or administered, or constitute, or form the basis of, a Force Majeure Event.

11.02 Changes Resulting in Costs or Benefits to Seller.

- (a) ISO Change Cost.

As of the Master Agreement Effective Date, it is uncertain how a Change in ISO Tariff may affect ISO charges to Seller or Seller's Actual Revenue.

Hereinafter, the total net incremental changes in ISO charges to Seller and Seller's Actual Revenue for any Facility Term Year as a result of a Change in ISO Tariff in the following specific circumstances shall be collectively referred to in the aggregate as the "ISO Change Cost":

- (i) Upon the occurrence of congestion on the transmission system, or the allocation of available transmission capacity among generators including Seller, impacting Seller's Scheduled Amounts (if SCE is not acting as Seller's Scheduling Coordinator), Delivered Amounts (if

SCE is acting as Seller's Scheduling Coordinator), Metered Amounts or congestion-related charges to Seller resulting thereof;

- (ii) The method of calculating, assessing and charging Seller for transmission losses for the delivery of electric energy from the Generating Facility to the Delivery Point including electrical losses occurring over the ISO Grid, and any changes in Seller's Scheduled Amounts (if SCE is not acting as Seller's Scheduling Coordinator) or Delivered Amounts (if SCE is acting as Seller's Scheduling Coordinator) resulting from the assessment of transmission losses thereto; and
- (iii) Changes in, or elimination of, the Participating Intermittent Resource Program, including changes in rates assessed by the ISO in respect of the ISO PIRP Charges (other than a change that reduces ISO Grid Management Charges applicable to Participating Intermittent Resources), changes in GMMs or any line loss related factors associated with the PIRP and changes in Seller's Scheduling Coordinator costs in the event that SCE becomes Seller's Scheduling Coordinator as a result of changes in, or elimination of, the PIRP.

"ISO Change Cost" shall not include ISO Charges (prior to the Startup Period), ISO Sanctions or SCE Penalties paid by Seller in accordance with Section 3.19(b) and Exhibit R.

The procedure for determining an ISO Change Cost is described in Exhibit P.

In the event of an inconsistency between this Section 11.02 and Exhibit P concerning the determination of an ISO Change Cost or ISO Change Cost Payment, Exhibit P shall govern.

(b) ISO Change Cost Payment.

It is the intent of the Parties that Seller shall be reimbursed by SCE by the amount of one-half ($\frac{1}{2}$) of the ISO Change Cost below the ISO Change Cost Threshold Amount, and by the amount of the ISO Change Cost above the ISO Change Cost Threshold Amount, if the ISO Change Cost has been a cost to Seller; and further, that SCE shall be paid by Seller by the amount of one-half ($\frac{1}{2}$) of the ISO Change Cost below the ISO Change Cost Threshold Amount, and by the amount of the ISO Change Cost above the ISO Change Cost Threshold Amount, if the ISO Change Cost has been a savings to Seller (collectively, the "ISO Change Cost Payment").

The procedure for calculating the total net incremental change in ISO charges to Seller or Seller's Actual Revenue during any Facility Term Year associated

with an ISO Change Cost and for calculating any payment owed to a Party in respect of an ISO Change Cost is described in Exhibit P.

The procedure for addressing disputes related to an ISO Change Cost determination is set forth in Section 11.03 below.

In addition, it is the intent of the Parties that SCE be afforded certain rights after a Change in ISO Tariff to mitigate an ISO Change Cost owing from SCE.

These mitigation rights, the circumstances in which rights may be exercised and the procedure for exercising such rights are set forth in Section 11.04.

11.03 Procedure for Claiming an ISO Change Cost Payment.

(a) Notice of Claim for an ISO Change Cost Payment.

If either Party believes that it is owed an ISO Change Cost Payment for any Facility Term Year, it shall, on or before the sixtieth (60th) day after the end of the Facility Term Year, provide Notice to the other Party of its claim for the ISO Change Cost Payment.

Such a Notice must include the Party's explanation for its claim that a Change in ISO Tariff has occurred, the Party's calculation supporting its ISO Change Cost Payment claim in accordance with Exhibit P, and annotated workpapers and source data supporting the Party's calculation.

If either Party reasonably believes that the annual ISO Change Cost Payment owed to such Party will be more than \$1,000,000, it may provide a Notice to the other Party under this Section 11.03, in which case payments shall be made quarterly based upon estimated values, to be trued up at the end of the Facility Term Year.

(b) Payment of Claim.

Within forty five (45) days from the date Notice of an ISO Change Cost Payment is provided pursuant to this Section 11.03, a Party receiving a claim for an ISO Change Cost Payment shall either:

- (i) Pay the claim; or
- (ii) Provide Notice to the claiming Party that it disputes the claim and pay any portion of the claim which it does not dispute.

The Party's Notice that it disputes the claim shall set forth in detail the reason for its dispute, and shall include the disputing Party's calculation of the ISO Change Cost and any ISO Change Cost

The contents of this document are subject to restrictions on disclosure as set forth herein.

Payment in accordance with Exhibit P as well as annotated workpapers and source data supporting the disputing Party's calculations.

(c) Disputed Claims.

The Parties shall negotiate in good faith to resolve any dispute regarding a claim for the ISO Change Cost Payment and shall, as part of such good faith negotiations, promptly provide information or data relevant to the dispute as they each may possess which is requested by the other Party.

Such information may be provided pursuant either to Section 10.10 or to such other agreement that the Parties shall negotiate to provide reasonable protection for their confidential business information or trade secrets.

If the Parties are unable to resolve a dispute regarding a claim for the ISO Change Cost Payment within forty five (45) days of the sending of Notice by the disputing Party pursuant to this Section 11.03, either Party may submit the dispute to mediation and arbitration as provided in Article Twelve.

11.04 SCE's Mitigation Rights.

(a) Mitigation Rights.

After a Change in ISO Tariff, SCE shall have the rights (individually, or in any combination, the "SCE Mitigation Rights"), subject to the limitations set forth below in Section 11.04(b) to:

- (i) Make any decisions regarding Seller's bids for congestion in ISO-administered markets in order to:
 - (1) Minimize SCE cost exposure to any ISO Change Cost Payment to Seller with respect to this Article Eleven and Exhibit P; and
 - (2) Minimize Seller's cost exposure with respect to Article Eleven and Exhibit P,

which decision-making right shall become effective upon SCE providing to Seller three (3) Business Days Notice, provided, however, that:

- (3) Any changes in ISO charges or Seller's Actual Revenue as a result of the exercise of SCE's Mitigation Rights be accounted for in any calculation to be made pursuant to Exhibit P;
- (4) Prior to giving the above-described Notice of its intent to exercise decision-making rights, SCE shall make commercially reasonable efforts to consult with Seller regarding an

The contents of this document are subject to restrictions on disclosure as set forth herein.

adjustment bidding strategy and shall make commercially reasonable efforts to consult with Seller upon making material changes to such strategy; and

- (5) SCE shall only exercise its decision-making right in full compliance with the ISO Tariff, including the requirements of PIRP and Applicable Law, and shall not exercise its decision-making right in a manner that causes Seller to experience any adverse financial effect as a direct result of SCE exercising such decision-making rights for which Seller shall not be compensated under Sections 11.02 and 11.03 or otherwise.
 - (ii) Become Seller's Scheduling Coordinator in replacement of any person or entity providing Scheduling Coordinator services for Seller, which Scheduling Coordinator change shall become effective upon SCE providing to Seller forty five (45) days Notice if SCE is not satisfied that its bids are being implemented by Seller in a cost effective manner in accordance with SCE's instructions. The provisions of Section 3.19(b) and Section 4.05 shall not apply if SCE is acting as Seller's Scheduling Coordinator under this Section 11.04(a)(ii) and Seller is in PIRP or a successor program, but shall apply if SCE is acting as Seller's Scheduling Coordinator under this Section 11.04(a)(ii) and Seller is not in PIRP or a successor program.
- (b) Limitations to Exercising Mitigation Rights.
- SCE may exercise the SCE Mitigation Rights if, in addition to a Change in ISO Tariff, any of the following occurs:
- (i) SCE makes an ISO Change Cost Payment to Seller for any Facility Term Year in excess of fifty thousand dollars (\$50,000) and the Notice of exercise of SCE's Mitigation Rights pursuant to Section 11.04(a) is provided within one hundred twenty (120) days from the date of such ISO Change Cost Payment;
 - (ii) If SCE is reasonably likely to incur an ISO Change Cost Payment to Seller for any Facility Term Year in excess of seventy five thousand dollars (\$75,000); or
 - (iii) If SCE is reasonably likely to incur an ISO Change Cost Payment to Seller for any Facility Term Year in excess of fifty thousand dollars (\$50,000), and PIRP has been eliminated or materially modified and there is no successor program to PIRP that is substantially equivalent to PIRP acceptable to both Parties.
- (c) Procedures for Exercising Mitigation Rights.

The contents of this document are subject to restrictions on disclosure as set forth herein.

Any Notice of SCE's exercise of the SCE Mitigation Rights shall set forth the basis for SCE's determination that one or more of the circumstances set forth in Section 11.04(a)(ii) has occurred, including SCE's calculation of any actual or forecast ISO Change Cost Payment, along with annotated workpapers and source data supporting SCE's calculation.

If SCE provides Notice that it is exercising the SCE Mitigation Rights to become Seller's Scheduling Coordinator:

- (i) SCE shall reimburse Seller for any cost or liability to Seller up to a maximum amount of twenty five thousand dollars (\$25,000) associated with the termination of Seller's arrangements with its then-existing Scheduling Coordinator and its transition of its Scheduling Coordinator relationship to SCE;
 - (ii) If Seller is in PIRP or a successor program, the Parties shall promptly enter into a Scheduling Coordinator agreement that is acceptable to both Parties containing substantially similar terms and conditions, including cost of service terms, as those in effect between Seller and its Scheduling Coordinator at the time Notice is given; and
 - (iii) Seller shall pay SCE for ISO PIRP Charges (if Seller is in PIRP or a successor program) or, if PIRP has been eliminated, for forecasting fees equivalent to those that it would have paid under PIRP as of the Master Agreement Effective Date, provided that such costs are not otherwise being paid by Seller.
- (d) Scheduling Decisions upon Exercising Mitigation Rights.

In the event SCE elects to become Seller's Scheduling Coordinator and Seller is in PIRP or a successor program, SCE shall submit the PIRP forecast for the Generating Facility as Seller's schedule.

*** *End of ARTICLE ELEVEN* ***

ARTICLE TWELVE. MEDIATION AND ARBITRATION

12.01 Dispute Resolution.

- (a) Any and all disputes, claims or controversies arising out of, relating to, concerning or pertaining to the terms of this Power Purchase Agreement, or to either Party's performance or failure of performance under this Power Purchase Agreement ("Dispute"), which Dispute the Parties have been unable to resolve by informal methods after undertaking a good faith effort to do so, shall first be submitted to mediation under the procedures described in Section 12.02 below, and if the matter is not resolved through mediation, then for final and binding arbitration under the procedures described in Section 12.03 below.
- (b) The Parties waive any right to a jury and agree that there shall be no interlocutory appellate relief (such as writs) available.

12.02 Mediation.

Either Party may initiate mediation by providing Notice to the other Party in accordance with Section 10.08 of a written request for mediation, setting forth a description of the Dispute and the relief requested. The Parties will cooperate with one another in selecting the mediator ("Mediator") from the panel of neutrals from Judicial Arbitration and Mediation Services, Inc. ("JAMS"), its successor, or any other mutually acceptable non-JAMS Mediator, and in scheduling the time and place of the mediation. Such selection and scheduling shall be completed within forty five (45) days after Notice of the request for mediation. Unless otherwise agreed to by the Parties, the mediation shall not be scheduled for a date that is greater than one hundred twenty (120) days from the date of Notice of the request for mediation. The Parties covenant that they will participate in the mediation in good faith, and that they will share equally in its costs (other than each Party's individual attorneys' fees and costs related to the Party's participation in the mediation, which fees and costs shall be borne by such Party). All offers, promises, conduct and statements, whether oral or written, made in connection with or during the mediation by either of the Parties, their agents, representatives, employees, experts and attorneys, and by the Mediator or any of the Mediator's agents, representatives and employees, shall not be subject to discovery and shall be confidential, privileged and inadmissible for any purpose, including impeachment, in any arbitration or other proceeding between or involving the Parties, or either of them, provided that evidence that is otherwise admissible or discoverable shall not be rendered inadmissible or non-discoverable as a result of its use in the mediation.

12.03 Arbitration.

- (a) Either Party may initiate binding arbitration with respect to the matters first submitted to mediation by providing Notice in accordance with Section 10.08 of a demand for binding arbitration before a single, neutral arbitrator (the "Arbitrator") at any time following the unsuccessful conclusion of the mediation provided for above.
- (b) The Parties will cooperate with one another in selecting the Arbitrator within sixty (60) days after Notice of the demand for arbitration and shall further cooperate in scheduling the arbitration to commence no later than one hundred eighty (180) days from the date of Notice of the demand. If, notwithstanding their good faith efforts, the Parties are unable to agree upon a mutually-acceptable Arbitrator, the Arbitrator shall be appointed as provided for in California Code of Civil Procedure section 1281.6. To be qualified as an Arbitrator, each candidate must be a retired judge of a trial court of any state or federal court, or retired justice of any appellate or supreme court. Unless otherwise agreed to by the Parties, the individual acting as the Mediator shall be disqualified from serving as the Arbitrator in the dispute, although the Arbitrator may be another member of the JAMS panel of neutrals or such other panel of neutrals from which the Parties have agreed to select the Mediator.
- (c) Upon Notice of a Party's demand for binding arbitration, such Dispute submitted to arbitration, including the determination of the scope or applicability of this agreement to arbitrate, shall be determined by binding arbitration before the Arbitrator, in accordance with the laws of the State of California, without regard to principles of conflicts of laws. Except as provided for herein, the arbitration shall be conducted by the Arbitrator in accordance with the rules and procedures for arbitration of complex business disputes for the organization with which the Arbitrator is associated; absent the existence of such rules and procedures, the arbitration shall be conducted in accordance with the California Arbitration Act, California Code of Civil Procedure Section 1280 *et seq.* and California procedural law (including the Code of Civil Procedure, Civil Code, Evidence Code and Rules of Court, but excluding local rules).
- (d) Notwithstanding the rules and procedures that would otherwise apply to the arbitration, and unless the Parties agree to a different arrangement, the place of the arbitration shall be in Los Angeles County, California.
- (e) Also notwithstanding the rules and procedures that would otherwise apply to the arbitration, and unless the Parties agree to a different arrangement, discovery will be limited as follows:

The contents of this document are subject to restrictions on disclosure as set forth herein.

-
- (i) Before discovery commences, the Parties shall exchange an initial disclosure of all documents and percipient witnesses which they intend to rely upon or use at any arbitration proceeding (except for documents and witnesses to be used solely for impeachment);
 - (ii) The initial disclosure shall occur within thirty (30) days after the initial conference with the Arbitrator or at such time as the Arbitrator may order;
 - (iii) Discovery may commence at any time after the Parties' initial disclosure;
 - (iv) The Parties will not be permitted to propound any interrogatories or requests for admissions;
 - (v) Discovery shall be limited to twenty five (25) document requests (with no subparts), three (3) lay witness depositions, and three (3) expert witness depositions (unless the Arbitrator holds otherwise following a showing by the Party seeking the additional documents or depositions that the documents or improperly withheld documents);
 - (vi) Each Party is allowed a maximum of three (3) expert witnesses, excluding rebuttal experts;
 - (vii) Within sixty (60) days after the initial disclosure, or at such other time as the Arbitrator may order, the Parties shall exchange a list of all experts upon which they intend to rely at the arbitration proceeding;
 - (viii) Within thirty (30) days after the initial expert disclosure, the Parties may designate a maximum of two (2) rebuttal experts;
 - (ix) Unless the Parties agree otherwise, all direct testimony shall be in form of affidavits or declarations under penalty of perjury; and
 - (x) Each Party shall make available for cross examination at the arbitration hearing its witnesses whose direct testimony has been so submitted.
- (f) Judgment on the award may be entered in any court having jurisdiction. The Arbitrator shall, in any award, allocate all of the costs of the binding arbitration (other than each Party's individual attorneys' fees and costs related to the Party's participation in the arbitration, which fees and costs shall be borne by such Party), including the fees of the Arbitrator and any expert witnesses, against the Party who did not prevail. Until such award is made, however, the Parties shall share equally in paying the costs of the arbitration.

12.04 Waivers.

SELLER AGREES THAT SELLER WILL NOT AT ANY TIME INSIST UPON, PLEAD, CLAIM OR TAKE THE BENEFIT OR ADVANTAGE OF ANY LAW NOW OR HEREAFTER IN FORCE REQUIRING FORECLOSURE OF ANY RIGHTS GRANTED TO SCE BY SELLER UNDER ANY DEED OF TRUST BEFORE TAKING ANY ACTION DESCRIBED IN SECTIONS 12.02 AND 12.03 HEREOF.

**** End of ARTICLE TWELVE ****

In WITNESS WHEREOF, the Parties have caused this Power Purchase Agreement to be duly executed as of the Power Purchase Agreement Effective Date first written:

ALTA WIND VI, LLC,

**SOUTHERN CALIFORNIA EDISON
COMPANY,**

a Delaware limited liability company.

a California corporation.

By:

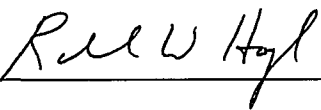

Randall Hoyle
Vice President

By:



Marc Ulrich
Vice President
Renewable and Alternative Power

Date: 2/23/10

Date: 3/9/2010

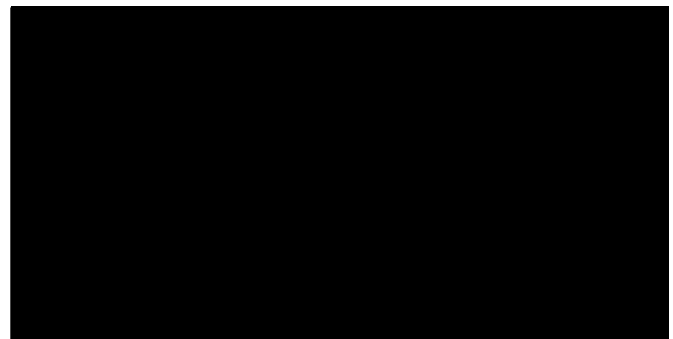

In WITNESS WHEREOF, the Parties have caused this Power Purchase Agreement to be duly executed as of the Power Purchase Agreement Effective Date first written:

ALTA WIND VI, LLC,

**SOUTHERN CALIFORNIA EDISON
COMPANY,**

a Delaware limited liability company.

a California corporation.

By:

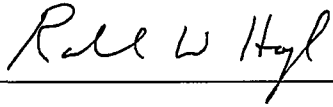

Randall Hoyle
Vice President

Date: 2/23/10

By:

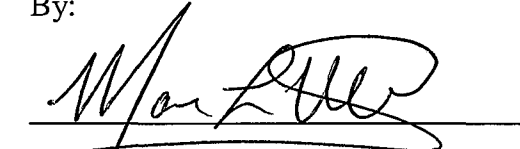

Marc Ulrich
Vice President
Renewable and Alternative Power

Date: 3/9/2010

EXHIBIT A

Definitions

The contents of this document are subject to restrictions on disclosure as set forth herein.

EXHIBIT A*Definitions*

The following terms shall have the following meaning for purposes of this Power Purchase Agreement. Unless expressly stated otherwise, sections and exhibits referenced herein refer to sections and exhibits of this Power Purchase Agreement.

1. “Actual Available Capacity” means the sum of the capacity, in MWs, of all generating units of the Generating Facility that were available as of the end of an hour, as indicated by the Actual Availability Report.
2. “Actual Availability Report” has the meaning set forth in Section 3.19(b)(ix)(1).
3. “Actual Generating Facility Annual Availability” means the overall annual wind turbine availability percentage result for one Facility Term Year that is:
 - a) Provided by Seller in a Notice to SCE in accordance with Section 3.05(b) after the end of each of the first ten (10) Facility Term Years; and
 - b) Calculated:
 - i) By the Generating Facility’s control system for all Generating Facility Wind Turbines; and
 - ii) In a manner consistent with the method prescribed by the Wind Turbine manufacturer.
4. “Actual Generating Facility Long Term Availability” means the overall wind turbine availability percentage result for each of Seller’s *First* Long Term Availability Guarantee Period and Seller’s *Second* Long Term Availability Guarantee Period that is:
 - a) Provided by Seller in a Notice to SCE in accordance with Section 3.05(b) after the end of the fifth (5th) and tenth (10th) Facility Term Years; and
 - b) Calculated:
 - i) By the Generating Facility’s control system for all Generating Facility Wind Turbines; and
 - ii) In a manner consistent with the method prescribed by the Wind Turbine manufacturer.
5. “Affiliate” means, with respect to a Party or another entity, any entity that, directly or indirectly, through one or more intermediaries, Controls, or is Controlled by, or is under common Control with such Party or other entity. Alta Innovative Power

The contents of this document are subject to restrictions on disclosure as set forth herein.

Company, a Delaware limited liability company shall be considered an "Affiliate" of Seller so long as any Affiliate of Seller satisfying the first sentence of this definition owns at least 50% of the ownership interest in Alta Innovative Power Company.

6. "Applicable Law" means all constitutions, treaties, laws, ordinances, rules, regulations, interpretations, permits, judgments, decrees, injunctions, writs and orders of any Governmental Authority that apply to either or both of the Parties, the Generating Facility or the terms of this Power Purchase Agreement.
7. "Arbitrator" has the meaning set forth in Section 12.03.
8. "Authority to Construct" means an application or other appropriate request with the appropriate Air Pollution Control District for determination that construction of the Generating Facility is authorized under applicable air pollution control laws and regulations.
9. "Availability Deviation" means the absolute value of the difference, in MW, in any hour between:
 - a) The Forecasted Available Capacity for the hour, as indicated by the Availability Forecast; and
 - b) The Actual Available Capacity for the hour, as indicated by the Actual Availability Report.
10. "Availability Forecast" has the meaning set forth in Exhibit Q.
11. "Availability Workbook" has the meaning set forth in Exhibit S.
12. "Bankrupt" means with respect to any entity, such entity:
 - a) Files a petition or otherwise commences, authorizes or acquiesces in the commencement of a proceeding or cause of action under any bankruptcy, insolvency, reorganization or similar law, or has any such petition filed or commenced against it, which petition is not dismissed within sixty (60) days;
 - b) Makes an assignment or any general arrangement for the benefit of creditors;
 - c) Otherwise becomes bankrupt or insolvent (however evidenced);
 - d) Has a liquidator, administrator, receiver, trustee, conservator or similar official appointed with respect to it or any substantial portion of its property or assets; or
 - e) Is generally unable to pay its debts as they fall due.

13. "Benchmark Bid Price" means, for each calendar year, such applicable price referenced by such name and set forth in Table A in Exhibit L.
14. "Business Day" means any day except a Saturday, Sunday, a Federal Reserve Bank holiday, or the Friday following Thanksgiving. A Business Day shall begin at 8:00 a.m. and end at 5:00 p.m. local time for the Party sending the Notice or payment or performing a specified action.
15. "Buyer" means Southern California Edison Company.
16. "Capacity Attributes" means any and all current or future defined characteristics, certificates, tag, credits, ancillary service attributes, or accounting constructs, howsoever entitled, including any accounting construct counted toward any resource adequacy requirements, attributed to or associated with the capacity of the Generating Facility during the Facility Term.
17. "CEC" means the California Energy Commission.
18. "CEC Certification and Verification" means a determination from the CEC that the Generating Facility is certified (or, with respect to periods before the Generating Facility has been constructed, that the Generating Facility is pre-certified) as an ERR for purposes of the RPS Legislation and that all electric energy produced by the Generating Facility qualifies as generation from an ERR for purposes of the RPS Legislation.
19. "Change in ISO Tariff" means that the ISO Tariff has been changed and such change has, or would have had, a financial impact on either Party, or the ISO has been dissolved or replaced and any successor to the ISO operates under rules, protocols, procedures or standards that differ in a material respect from the ISO Tariff, after the Master Agreement Effective Date.
20. "Claiming Party" has the meaning set forth in Section 5.02.
21. "Collateral Assignment Agreement" has the meaning set forth in Section 10.05.
22. "Confidential Information" shall mean the non-public terms and conditions of this Power Purchase Agreement and all oral and written communications related to this Power Purchase Agreement exchanged between the Parties, except that "Confidential Information" shall not include:
 - a) Information which is in the public domain as of the Power Purchase Agreement Effective Date or which later comes into the public domain from a source other than from the receiving Party or its Permitted Disclosee;

- b) Information which the receiving Party can demonstrate in writing was already known to the receiving Party prior to the Power Purchase Agreement Effective Date;
 - c) Information which comes to a receiving Party from a *bona fide* third party source not under an obligation of confidentiality;
 - d) Information which is independently developed by a receiving Party without use of or reference to Confidential Information or information containing Confidential Information; or
 - e) The fact that the Parties have entered into this Power Purchase Agreement.
23. "Control" or "Controlled" means the ability to direct the management and policies of another entity, whether through the ownership of a majority of voting shares, by contract or otherwise.
24. "Control Area" means the electric power system (or combination of electric power systems) under the operational control of the ISO or any other electric power system under the operational control of another organization vested with authority comparable to that of the ISO.
25. "Costs" means, with respect to the Non-Defaulting Party, brokerage fees, commissions, legal expenses and other similar third party transaction costs and expenses reasonably incurred by such Party in entering into any new arrangement which replaces this Power Purchase Agreement.
26. "CPUC" means the California Public Utilities Commission.
27. "Credit Rating" means with respect to any entity, on the relevant date of determination, the respective ratings then assigned to such entity's unsecured, senior long-term debt or deposit obligations (not supported by third party credit enhancement) by S&P or Moody's. If no rating is assigned to such entity's unsecured, senior long-term debt or deposit obligation by either S&P or Moody's, *then* "Credit Rating" means the general corporate credit rating or long-term issuer rating assigned by S&P or Moody's, as the case may be.
28. "Cross Default Amount" has the meaning set forth in 1.07(b).
29. "Debt to Equity Ratio" means the quotient of $X/(Y-X)$, where:
- X = The aggregate amount outstanding under any then-outstanding Senior Loan on the date on which a Senior Lender first advances funds under its Senior Loan (not including any date on which a Tax Equity Provider advance funds used to pay another Senior Lender); and

Y = (a) In connection with the first Permanent Financing, the total capital cost of the Generating Facility and all capital items associated therewith, and (b) in connection with any subsequent Senior Loan, the fair market value of the Generating Facility (taking into account this Power Purchase Agreement and future market opportunities after expiration of this Power Purchase Agreement, including expected revenues therefrom), and all capital items associated therewith, as determined by an independent third-party appraiser selected by Seller, subject to SCE's consent (which consent shall not be withheld, conditioned or delayed unreasonably). In the event that SCE reasonably rejects the appraiser selected by Seller, SCE may select its own independent third-party appraiser, subject to Seller's consent (which consent shall not be withheld, conditioned or delayed unreasonably), and the fair market value of the Generating Facility shall be the average of the two appraisals.

30. "Defaulting Party" has the meaning set forth in Section 6.01.
31. "Delivered Amounts" means the Metered Amounts adjusted by Delivery Losses.
32. "Delivery Losses" means all electric energy losses occurring between the ISO Approved Meter and the Delivery Point and electric energy losses occurring over the ISO Grid as such losses are assigned by the ISO to the Generating Facility including if applicable, but not limited to:
- a) If the ISO Approved Meter is not installed on the high voltage side of the Generating Facility's substation bus bar, transformer and other electric energy losses occurring between the ISO Approved Meter and the high voltage side of the Generating Facility's substation bus bar;
 - b) Any applicable DLF or TLF, or if no DLF is applicable, *then* electric energy losses between the high voltage side of the Generating Facility's substation bus bar and the ISO Grid; and
 - c) Electric energy losses determined by utilizing the GMM, or TMM if applicable, assigned to the Generating Facility.
33. "Delivery Point" means ISO Zone SP-15.

Notwithstanding anything to the contrary in Article Eleven, after a Change in ISO Tariff that materially impacts the trading points or trading rules thereof in ISO Zone SP-15, the "Delivery Point" shall be a valid Scheduling point in SP-15 that is either:

- a) The SCE load aggregation point, if defined by the ISO; or
- b) If an SCE load aggregation point is not defined by the ISO, the ISO-defined trading hub designated by SCE as most closely representing SCE's bundled customer load.

-
34. "Delivery Term" or "Term" means the Facility Term.
 35. "Demonstrated Nameplate Contract Capacity" has the meaning set forth in Section 3.04(c).
 36. "Developer" has the meaning set forth in the Preamble.
 37. "Disclosing Party" has the meaning set forth in Section 10.10(a).
 38. "Disclosure Order" has the meaning set forth in Section 10.10(a).
 39. "Dispute" has the meaning set forth in Section 12.01(a).
 40. "DLF" means a measure of all net electric energy losses as determined by the CPUC associated with the transmission of electric energy through the electric system from the high voltage side of the Generating Facility's substation bus bar to the interface with the ISO Grid, also known as the distribution loss factor.
 41. "Early Termination Date" has the meaning set forth in Section 6.02(a).
 42. "EIRP" has the meaning set forth in Section 3(a) of Exhibit D.
 43. "Emergency" means:
 - a) An actual or imminent condition or situation which jeopardizes the integrity of Transmission Provider's electric system or the integrity of any other systems to which the Transmission Provider's electric system is connected, as determined by the Transmission Provider in its reasonable discretion, or any condition so defined and declared by the ISO; or
 - b) An emergency condition as defined under an interconnection agreement and any abnormal interconnection or system condition that requires automatic or immediate manual action to prevent or limit loss of load or generation supply, that could adversely affect the reliability of the Transmission Provider's electric system or generation supply, that could adversely affect the reliability of any interconnected system, or that could otherwise pose a threat to public safety.
 44. "Energy Payment" means the amount calculated pursuant to Section 4.02(a).
 45. "Energy Payment Allocation Factor" has the meaning given in the table referenced by such name in Exhibit K.
 46. "Energy Price" has the meaning set forth in Section 1.02.

47. "Energy Price Adjustment" shall mean the Energy Price Adjustment as provided in Section 3(d) of the Final Notice to Proceed for the Generating Facility, attached hereto as Exhibit B.
48. "Equitable Defense" means any bankruptcy, insolvency, reorganization and other laws affecting creditors' rights generally, and with regard to equitable remedies, the discretion of the court before which proceedings to obtain same may be pending.
49. "ERR" means an Eligible Renewable Energy Resource as such term is defined in Public Utilities Code Section 399.12 or Section 399.16.
50. "Estimated Annual Production" means the estimated annual net output of the Generating Facility at the ISO Approved Meter based on the P50 Value in the Final Wind Report in MWh, as may be revised based on updated Final Wind Reports.
51. "Event of Default" has the meaning set forth in Section 6.01.
52. "Expected Construction Commencement Date" shall mean the Expected Construction Commencement Date as provided in Section 2(c) of the Final Notice to Proceed for the Generating Facility, attached hereto as Exhibit B, as such date may be extended pursuant to the terms of this Power Purchase Agreement.
53. "Expected Initial Operation Date" has the meaning set forth in Section 1.03.
54. "Facility Study" has the meaning set forth in the ISO Tariff.
55. "Facility Term" has the meaning used in Section 1.05.
56. "Facility Term Year" means a twelve (12) month period beginning on the first day of the calendar month following the Firm Operation Date and each successive twelve (12) month period thereafter.
57. "Federal Funds Effective Rate" means the annual interest rate posted opposite the caption "Federal Funds (effective)" as set forth in the weekly statistical release as H.15(519), or any successor publication, published by the Board of Governors of the Federal Reserve System.
58. "Federal Production Tax Credit Legislation" means validly enacted federal legislation extending the applicability and rate (plus escalation as specified in 26 U.S.C. § 45) of the Production Tax Credit (26 U.S.C. § 45) to owners of generating facilities which use wind to produce electric energy, on terms no less favorable to owners of wind generating facilities than those available with respect to such facilities placed in service on or after January 1, 2007 and before January 1, 2008 pursuant to the law governing Production Tax Credits as in effect on the Master Agreement Effective Date.
59. "FERC" means the Federal Energy Regulatory Commission.

The contents of this document are subject to restrictions on disclosure as set forth herein.

60. "Final Energy Price" shall mean the Final Energy Price as provided in Section 3(e) of the Final Notice to Proceed for the Generating Facility, attached hereto as Exhibit B.
61. "Final Hour-Ahead Schedule" has the meaning set forth in the ISO Tariff.
62. "Final Notice to Proceed" means the Notice attached hereto as Exhibit B.
63. "Final Wind Report" means the unabridged and unredacted final report concerning the electric energy producing potential of the Site that:
- a) Is prepared for Seller by an independent wind resource expert;
 - b) Used by Seller:
 - i) For predicting the Energy Payments that the Generating Facility will earn during the Facility Term;
 - ii) To obtain its construction or permanent financing of the Generating Facility; and
 - c) Contains a P50 Value prediction for the Generating Facilities annual Energy Payments.
64. "Firm Operation Date" means the last day of the calendar month which is six (6) months after the Initial Operation Date, plus any additional days for Force Majeure as provided in Section 5.04, or such other date agreed to in a writing signed by both Parties.
65. "Force Majeure" or "Force Majeure Event" means any occurrence that:
- a) In whole or in part, delays a Party's performance under this Power Purchase Agreement, causes a Party to be unable to perform its obligations, or prevents a Party from complying with or satisfying the conditions of this Power Purchase Agreement;
 - b) Is not within the reasonable control of that Party; and
 - c) The Party has been unable to overcome by the exercise of due diligence, including, but not limited to, an act of God, flood, drought, earthquake, storm, fire, pestilence, lightning and other natural catastrophes, epidemic, war, riot, civil disturbance or disobedience, terrorism, sabotage, strike or labor dispute, or actions or inactions of any Governmental Authority (including in respect of Material Permits beyond the normal processing and approval period therefor), or curtailment or reduction in deliveries at the direction of a Transmission Provider or the ISO except as set forth below.

Force Majeure does not include:

The contents of this document are subject to restrictions on disclosure as set forth herein.

- d) The lack of wind, sun or other fuel source of an inherently intermittent nature; nor
 - e) Curtailment or reduction in deliveries at the direction of a Transmission Provider or the ISO when the basis of the curtailment or reduction in deliveries ordered by a Transmission Provider or the ISO is congestion arising in the ordinary course of operations of the Transmission Provider's system or the ISO Grid, including congestion caused by outages or capacity reductions for maintenance, construction or repair.
66. "Forecast" or "Forecasting" means the action of Seller in preparing and submitting to SCE, in accordance with Exhibit Q, the Availability Forecasts.
67. "Forecasted Available Capacity" means the sum of the capacity, in MWs, of all generating units of the Generating Facility that were Forecasted to be available as of the end of an hour, as indicated by the Availability Forecast.
68. "Forward Settlement Amount" means the Non-Defaulting Party's Costs and Losses, on the one hand, netted against its Gains, on the other.

If the Non-Defaulting Party's Costs and Losses exceed its Gains, *then* the Forward Settlement Amount shall be an amount owing to the Non-Defaulting Party.

If the Non-Defaulting Party's Gains exceed its Costs and Losses, *then* the Forward Settlement Amount shall be zero dollars (\$0).

The Forward Settlement Amount shall not include consequential, incidental, punitive, exemplary or indirect or business interruption damages.

69. "Gains" means, with respect to any Party, an amount equal to the net present value of the economic benefit to it, if any (exclusive of Costs), resulting from the termination of this Power Purchase Agreement for the remaining Facility Term of this Power Purchase Agreement, determined in a commercially reasonable manner.

Factors used in determining the economic benefit to a Party may include, without limitation, reference to information supplied by one or more third parties, which shall exclude Affiliates of the Non-Defaulting Party, including without limitation, quotations (either firm or indicative) of relevant rates, prices, yields, yield curves, volatilities, spreads or other relevant market data in the relevant markets, Market Price Referents set by the CPUC, comparable transactions, forward price curves based on economic analysis of the relevant markets, settlement prices for comparable transaction at liquid trading hubs (e.g., NYMEX), all of which should be calculated for the remaining Facility Term of this Power Purchase Agreement, but shall include the value of Green Attributes, Capacity Attributes and Resource Adequacy Benefits.

Only if the Non-Defaulting Party is unable, after using commercially reasonable efforts, to obtain third party information to determine the gain of economic benefits, then the Non-Defaulting Party may use information available to it internally suitable for such purpose in accordance with prudent industry practices

70. "Generating Facility" means Seller's electric generating facility as more particularly described in Exhibit 1 to the Final Notice to Proceed, attached hereto as Exhibit B, together with all Wind Turbines, materials, equipment systems, structures, features and improvements necessary to produce electric energy at such facility, excluding the Site, land rights and interests in land.
71. "GMM(s)" means the generation meter multipliers as determined by the ISO representing the calculation of all electric energy losses assigned to the Generating Facility associated with the transmission of electric energy delivered by the Seller over the ISO Grid, which values are, as of the Power Purchase Agreement Effective Date, posted by the ISO on its website. The values used in this Power Purchase Agreement shall be those appearing on the ISO website on the third (3rd) Business Day of the calendar month following the month for which such values are being applied.
72. "Generating Facility Power Curve" means a table used to estimate the Generating Facility's Metered Amounts as a function of the recorded wind speed at the Site as described in Exhibit M.
73. "Governmental Authority" means:
- a) Any United States federal, state, local, municipal or other government;
 - b) Any United States governmental, regulatory or administrative agency, commission, or other authority lawfully exercising or entitled to exercise any administrative, executive, judicial, legislative, police, regulatory or taxing authority or power; or
 - c) Any United States court or governmental tribunal.
74. "Governmental Charges" has the meaning set forth in Section 9.02.
75. "Green Attributes" means means any and all credits, benefits, emissions reductions, offsets, and allowances, howsoever entitled, attributable to the generation from the Project, and its displacement of conventional energy generation. Green Attributes include but are not limited to Renewable Energy Credits, as well as:
- (1) Any avoided emissions of pollutants to the air, soil or water such as sulfur oxides (SO_x), nitrogen oxides (NO_x), carbon monoxide (CO) and other pollutants;

The contents of this document are subject to restrictions on disclosure as set forth herein.

- (2) Any avoided emissions of carbon dioxide (CO₂), methane (CH₄), nitrous oxide, hydrofluorocarbons, perfluorocarbons, sulfur hexafluoride and other greenhouse gases (GHGs) that have been determined by the United Nations Intergovernmental Panel on Climate Change, or otherwise by law, to contribute to the actual or potential threat of altering the Earth's climate by trapping heat in the atmosphere;
- (3) The reporting rights to these avoided emissions, such as Green Tag Reporting Rights.

Green Tag Reporting Rights are the right of a Green Tag Purchaser to report the ownership of accumulated Green Tags in compliance with federal or state law, if applicable, and to a federal or state agency or any other party at the Green Tag Purchaser's discretion, and include without limitation those Green Tag Reporting Rights accruing under Section 1605(b) of The Energy Policy Act of 1992 and any present or future federal, state, or local law, regulation or bill, and international or foreign emissions trading program. Green Tags are accumulated on a MWh basis and one Green Tag represents the Green Attributes associated with one (1) MWh of energy.

Green Attributes do *not* include:

- (i) Any energy, capacity, reliability or other power attributes from the Project,
- (ii) Production tax credits associated with the construction or Operation of the Project and other financial incentives in the form of credits, reductions, or allowances associated with the Project that are applicable to a state or federal income taxation obligation,
- (iii) Fuel-related subsidies or "tipping fees" that may be paid to Seller to accept certain fuels, or local subsidies received by the generator for the destruction of particular preexisting pollutants or the promotion of local environmental benefits, or
- (iv) Emission reduction credits encumbered or used by the Project for compliance with local, state, or federal operating and/or air quality permits.

If the Project is a biomass or landfill gas facility and Seller receives any tradable Green Attributes based on the greenhouse gas reduction benefits or other emission offsets attributed to its fuel usage, it shall provide Buyer with sufficient Green Attributes to ensure that there are zero net emissions associated with the production of electricity from the Project.

The contents of this document are subject to restrictions on disclosure as set forth herein.

76. "Guarantor" has the meaning set forth in Section 1.07(a).
77. "Guaranty Agreement" means, if a Guarantor has been identified, the guaranty agreement from the Guarantor in the form attached hereto as Exhibit I or in such other form as is acceptable to SCE.
78. "Incipient Event of Default" has the meaning set forth in Section 10.05(a).
79. "Indemnifying Party" has the meaning set forth in Section 10.03(b).
80. "Initial Operation" has the meaning set forth in Section 2.03(b)(i).
81. "Initial Operation Date" means the date selected by Seller in accordance with Section 2.03(b)(i).
82. "Initial Synchronization" means the date upon which the Generating Facility is initially synchronized with Seller's Transmission Provider.
83. "Interconnection Point" means the point at which the Generating Facility interconnects with the Transmission Provider's transmission system or the ISO Grid.
84. "Interest Rate" means an annual rate equal to:
- (a) The rate published in The Wall Street Journal as the "Prime Rate" (or, if more than one rate is published, the arithmetic mean of such rates) as of the date payment is due; plus
 - (b) Two percentage points (2%);
- provided, however, that in no event shall the Interest Rate exceed the maximum interest rate permitted by Applicable Law.
85. "ISO" means the California Independent System Operator Corporation or successor entity that dispatches certain generating units and loads and controls the transmission facilities of entities that:
- a) Own, operate and maintain transmission lines and associated facilities or have entitlements to use certain transmission lines and associated facilities; and
 - b) Have transferred to the ISO or its successor entity operational control of such facilities or entitlements.
86. "ISO Approved Meter" has the meaning set forth in Section 3.06(a).
87. "ISO Approved Quantity" means, if SCE is not acting as Seller's Scheduling Coordinator, the electric energy quantity Scheduled by Seller's Scheduling Coordinator and approved by the ISO in its final schedule published in accordance

The contents of this document are subject to restrictions on disclosure as set forth herein.

with the ISO Tariff. "ISO Approved Quantity" means, if SCE is acting as Seller's Scheduling Coordinator, the electric energy quantity in a schedule request made by SCE acting as the Scheduling Coordinator, and as approved by the ISO in its final schedule published in accordance with the ISO Tariff.

88. "ISO Change Cost" has the meaning set forth in Section 11.02(a).
89. "ISO Change Cost Payment" means a payment for any Facility Term Year, either from SCE to Seller or from Seller to SCE, due to an ISO Change Cost as described in Section 11.02(b).
90. "ISO Change Cost Threshold Amount" means the threshold amount in Section 1.09 at the time any ISO Change Cost Payment is calculated pursuant to Exhibit P.
91. "ISO Charges" means the debits, costs, penalties and interest that are directly assigned by the ISO to the ISO Global Resource ID(s) for the Generating Facility for, or attributable to, scheduling or deliveries from the Generating Facility under this Power Purchase Agreement.
92. "ISO Declared Over-Generation Condition" mean a ISO declared condition on the ISO Grid where the sum of the desired generation output of all of the Scheduling Coordinators in the Control Area, absent mitigation, would be greater than the system load.
93. "ISO Forecasted Over-Generation Condition" mean a ISO forecasted condition on the ISO Grid where the sum of the desired generation output of all of the Scheduling Coordinators in the Control Area, absent mitigation, would be greater than the system load.
94. "ISO Global Resource ID" or "GRI" means the number or name assigned by the ISO to the ISO Approved Meter.
95. "ISO Grid" means the system of transmission lines and associated facilities and entitlements of the participating transmission owners that have been placed under the ISO's operational control.
96. "ISO Grid Management Charges" has the meaning set forth in the ISO Tariff.
97. "ISO PIRP Charges" means those ISO charges under the Participating Intermittent Resource Program identified as charge types 701, 711 and 721 (as of the Master Agreement Effective Date) as such charges are defined in the ISO Tariff, plus any forecast fee imposed by the ISO on Seller not included in such charges, or any successor charges that accomplish a similar purpose to any of the foregoing charges.
98. "ISO Sanctions" means any sanction directly assigned by the ISO to the ISO Global Resource ID(s) for the Generating Facility, or attributable to, scheduling or deliveries

The contents of this document are subject to restrictions on disclosure as set forth herein.

from the Generating Facility under this Power Purchase Agreement, in any case to the extent arising from a failure of Seller to comply with the ISO Tariff.

99. "ISO Tariff" means the California Independent System Operator Corporation Operating Agreement and Tariff, including the rules, protocols, procedures and standards attached thereto, as the same may be amended or modified from time-to-time and approved by FERC.
100. "JAMS" has the meaning set forth in Section 12.02.
101. "kW" means a kilowatt of electric energy generating capacity.
102. "kWh" means a kilowatt-hour of electric energy.
103. "Large Generator Interconnection Agreement" has the meaning set forth in the ISO Tariff.
104. "Lease" means one or more agreements whereby Seller leases the Site(s) described in Section 1.01(b) from a third party, the term of which lease begins on or before the commencement of the Facility Term and extends at least through the last day of the Facility Term.
105. "Lender" means any third party institution(s) or entity(ies) or successor(s) in interest or assignee(s) that provide(s) development, bridge, construction or permanent debt financing or refinancing for the Generating Facility to Seller or credit support in connection with this Power Purchase Agreement.
106. "Letter of Credit" means an irrevocable, nontransferable standby letter of credit issued by a U.S. commercial bank or a U.S. branch of a foreign bank with such bank having a Credit Rating of at least "A-" from S&P and "A3" from Moody's, substantially in the form of Exhibit N or in such other form as is reasonably acceptable to SCE.
107. "Letter of Credit Default" means with respect to a Letter of Credit, the occurrence of any of the following events:
 - a) The issuer of such Letter of Credit fails to maintain a Credit Rating of at least "A-" by S&P and "A3" by Moody's;
 - b) The issuer of the Letter of Credit fails to comply with or perform its obligations under such Letter of Credit;
 - c) The issuer of such Letter of Credit disaffirms, disclaims, repudiates or rejects, in whole or in part, or challenges the validity of, such Letter of Credit;
 - d) Such Letter of Credit fails or ceases to be in full force and effect at any time,

The contents of this document are subject to restrictions on disclosure as set forth herein.

- e) Seller fails to provide an extended or replacement Letter of Credit within twenty (20) Business Days before such Letter of Credit expires or terminates;
- f) The issuer of such Letter of Credit becomes Bankrupt;

provided that, no Letter of Credit Default shall occur or be continuing in any event with respect to a Letter of Credit after the time such Letter of Credit is required to be canceled or returned to a Party in accordance with the terms of this Power Purchase Agreement.

- 108. "LGIA Upgrades" means the environmental studies, engineering studies, engineering, design, procurement of materials and equipment and/or construction of transmission facilities and related items, in connection with transmission facilities located at or downstream of the Interconnection Point, set forth in the Generating Facility's Large Generator Interconnection Agreement.
- 109. "Local Business Day" means, a Business Day on which commercial banks are open for business (a) in relation to any payment, in the place where the relevant account is located and (b) in relation to any notice or other communication, in the location specified in the address for notice provided by the recipient, except for the Friday immediately following the U.S. Thanksgiving holiday or a Federal Reserve Bank holiday.
- 110. "Losses" means, with respect to any Party, an amount equal to the net present value of the economic loss to it, if any (exclusive of Costs), resulting from termination of this Power Purchase Agreement for the remaining Facility Term, determined in a commercially reasonable manner.

Factors used in determining economic loss to a Party may include, without limitation, reference to information supplied by one or more third parties, which shall exclude Affiliates of the Non-Defaulting Party, including without limitation, quotations (either firm or indicative) of relevant rates, prices, yields, yield curves, volatilities, spreads or other relevant market data in the relevant markets, Market Price Referents set by the CPUC, comparable transactions, forward price curves based on economic analysis of the relevant markets, settlement prices for comparable transaction at liquid trading hubs (e.g., NYMEX), all of which should be calculated for the remaining Facility Term of this Power Purchase Agreement and shall include the value of Green Attributes, Capacity Attributes and Resource Adequacy Benefits.

Only if the Non-Defaulting Party is unable, after using commercially reasonable efforts, to obtain third party information to determine the loss of economic benefits, *then* the Non-Defaulting Party may use information available to it internally suitable for such purpose in accordance with prudent industry practices.

- 111. "Lost Output" means the sum of the Metered Amounts over the relevant measurement period that the Generating Facility was available to produce and could reasonably

The contents of this document are subject to restrictions on disclosure as set forth herein.

have been expected to deliver, based the calculation method set forth in Exhibit M, but was not delivered due to:

- a) Force Majeure;
 - b) An Event of Default or an Incipient Event of Default where SCE is the Defaulting Party;
 - c) A curtailment or reduction of deliveries ordered or caused by the ISO, or the Transmission Provider; *provided that*, the basis of such curtailment or reduction is not an event caused by Seller; or
 - d) Testing the Generating Facility in order to certify the Generating Facility for resource adequacy purposes.
112. "Lost Output Report" means a report of Lost Output prepared in accordance with the procedures set forth in Section 3.18 and Exhibit M.
113. "Lost Output Workbook" has the meaning set forth in Exhibit M.
114. "Market Price" means the ISO Real-Time Price for uninstructed deviations or any successor price for short term imbalance electric energy, as such price or successor price is defined in the ISO Tariff Appendix A, that would apply to the Generating Facility, which values are, as of the Master Agreement Effective Date, posted by the ISO on its website.
- The values used in this Power Purchase Agreement will be those appearing on the ISO website on the third (3rd) Business Day of the calendar month following the month for which such prices are being applied.
115. "Market Price Referent" means the market price referent applicable to this Power Purchase Agreement, as determined by the CPUC in accordance with Public Utilities Code Section 399.15(c).
116. "MRTU" means the Change in ISO Tariff contemplated on the Master Agreement Effective Date known as the Market Redesign and Technology Upgrade.
117. "Material Terms" has the meaning set forth in Section 2.05(b)(viii).
118. "Materially More Favorable Terms" has the meaning set forth in Section 2.05(b)(viii).
119. "Master Agreement" has the meaning set forth in the Preamble.
120. "Master Agreement Effective Date" means the Effective Date of the Master Agreement, which date is December 21, 2006..

The contents of this document are subject to restrictions on disclosure as set forth herein.

121. "Material Permit" means any Permit necessary for the construction and Initial Operation of the Generating Facility.
122. "Mediator" has the meaning set forth in Section 12.02.
123. "Metered Amounts" means the electric energy produced by the Generating Facility and expressed in kWh, as measured by the ISO Approved Meter.
124. "Meter Service Agreement" has the meaning set forth in the ISO Tariff.
125. "Milestone Schedule" means Seller's schedule to develop the Generating Facility as set forth in Exhibit G, including any revisions thereto in accordance with this Power Purchase Agreement.
126. "Moody's" means Moody's Investor Services, Inc.
127. "MW" means a megawatt of electric energy generating capacity.
128. "MWh" means a megawatt-hour of electric energy.
129. "Nameplate Contract Capacity" means the electrical generating capacity set forth in Section 1.01(d), that Seller commits to install at the Site and that is subject to reduction as set forth in Sections 3.04(d) and 3.04(e).
130. "Non-Defaulting Party" has the meaning set forth in Section 6.02.
131. "Notice" means notices, requests, statements or payments provided in accordance with Section 10.08 and Exhibit C.
132. "Notice of Right of First Offer" means a Notice of SCE's Right of First Offer in the form attached hereto as Exhibit J.
133. "Official Records" means the Official Records of Kern County, California.
134. "OMAR" means the Operational Metering Analysis and Reporting System operated and maintained by the ISO as the repository of settlement quality meter data or its successor.
135. "Operate," "Operating" or "Operation" means to provide (or the provision of) all the operation, engineering, purchasing, repair, supervision, training, inspection, testing, protection, use, management, improvement, replacement, refurbishment, retirement, and maintenance activities associated with operating the Generating Facility in accordance with Prudent Electrical Practices.
136. "Outage Schedule" has the meaning set forth in Section 3.19(b)(vii).

137. "Over-Scheduling Settlement Interval Adjustment Amount" means the amount calculated as set forth in Exhibit E.
138. "P50 Value" means the long term estimate of the annual average electric energy production of the Generating Facility from the Final Wind Report, in MWh.
139. "Participating Generator Agreement" has the meaning set forth in the ISO Tariff.
140. "Participating Intermittent Resource" means an intermittent resource generating facility that is certified, and remains certified, under PIRP as set forth in the ISO Tariff.
141. "Participating Intermittent Resource Program" or "PIRP" means the ISO's intermittent resource program initially established pursuant to Amendment No. 42 of the California ISO Tariff in Docket No. ER02-922-000 or any successor program that SCE determines accomplishes a similar purpose.
142. "Party" or "Parties" have the meaning set forth in the Preamble.
143. "Performance Assurance" means collateral in the form of either cash, Letter(s) of Credit, or other security acceptable to SCE in its reasonable judgment.
144. "Performance Assurance Amount" has the meaning set forth in Section 1.06.
145. "Permanent Financing" means any Senior Loan with a term greater than five (5) years.
146. "Permits" means all applications, approvals, authorizations, consents, filings, licenses, orders, permits or similar requirements imposed by any Governmental Authority, or the ISO, in order to develop, construct, operate, maintain, improve, refurbish and retire the Generating Facility or to Schedule and deliver the electric energy produced by the Generating Facility to SCE, including the Authority to Construct permit.
147. "Permitted Disclosee" shall mean the Persons set forth in Sections 10.10(a)(i), 10.10(a)(ii), 10.10(a)(iii) and 10.10(a)(xiii).
148. "Permitted Lien" means (a) any lien for taxes, assessments or governmental charges not yet delinquent or that is being contested in good faith and by appropriate proceedings with all deposits or payments made that preclude a foreclosure or deed in lieu of foreclosure or tax sale thereunder, (b) any statutory lien for utility assessments or other charges or assessments arising in the ordinary course of business or by operation of law which is not yet due or delinquent, (c) any liens, title exceptions or other matters disclosed in any title policy, title report, title commitment or other title documentation actually delivered to SCE for the Site or Generating Facility, or any portion thereof, (d) any matters or conditions that would be disclosed in a standard

The contents of this document are subject to restrictions on disclosure as set forth herein.

ALTA survey of the Site or Generating Facility, (e) materialmen's, mechanics', workers', repairmen's, employees' or other like liens arising in the ordinary course of business for amounts not yet due, or that is being contested in good faith and by appropriate proceedings with all deposits or payments made that preclude a foreclosure or deed in lieu of foreclosure or tax sale thereunder, (f) all matters recorded in the public real estate records against the Site, (g) zoning or planning restrictions, permits and other restrictions or limitations on the use of real property, and (h) any liens or other title exceptions created by Seller with written approval of SCE.

149. "Permitted Transferee" means any entity, or entity with a parent or other Affiliate, that:
- a) Has a tangible net worth of not less than \$25,000,000; and
 - b) Has at least five (5) years of experience in the operation of wind power generation facilities (or shall have retained a reputable third party with such experience to operate and maintain the Generating Facility).
150. "Person" shall mean any individual, corporation, partnership, joint venture, association, joint-stock company, limited liability company, trust, unincorporated organization, government or any agency or political subdivision thereof, or any other legal entity.
151. "Power Purchase Agreement" has the meaning set forth in the Preamble.
152. "Power Purchase Agreement Effective Date" has the meaning set forth in the Preamble.
153. "Procurement Review Group" has the meaning set forth in Section 10.10(a).
154. "Product" means:
- a) All electric energy produced by the Generating Facility, net of Station Use and Delivery Losses; and
 - b) All associated Green Attributes, Capacity Attributes, and Resource Adequacy Benefits.
155. "Production Tax Credits" or "PTC" means production tax credits under Section 45 of the Internal Revenue Code as in effect from time-to-time during the Facility Term or any successor or other provision providing for a federal tax credit determined by reference to renewable electric energy produced from wind resources for which the Generating Facility is eligible.
156. "Project" means the Generating Facility.

The contents of this document are subject to restrictions on disclosure as set forth herein.

157. "Prudent Electrical Practices" means those practices, methods and acts that would be implemented and followed by prudent operators of electric energy generating facilities in the Western United States, similar to the Generating Facility, during the relevant time period, which practices, methods and acts, in the exercise of prudent and responsible professional judgment in the light of the facts known at the time the decision was made, could reasonably have been expected to accomplish the desired result consistent with good business practices, reliability and safety.

Prudent Electrical Practices shall include, at a minimum, those professionally responsible practices, methods and acts described in the preceding sentence that comply with manufacturers' warranties, restrictions in this Power Purchase Agreement, and the requirements of Governmental Authorities, WECC standards, the ISO and Applicable Law.

Prudent Electrical Practices shall also include taking reasonable steps to ensure that:

- a) Equipment, materials, resources, and supplies, including spare parts inventories, are available to meet the Generating Facility's needs;
- b) Sufficient operating personnel are available at all times and are adequately experienced and trained and licensed as necessary to operate the Generating Facility properly and efficiently, and are capable of responding to reasonably foreseeable emergency conditions at the Generating Facility and Emergencies whether caused by events on or off the Site;
- c) Preventive, routine, and non-routine maintenance and repairs are performed on a basis that ensures reliable, long term and safe operation of the Generating Facility, and are performed by knowledgeable, trained, and experienced personnel utilizing proper equipment and tools;
- d) Appropriate monitoring and testing are performed to ensure equipment is functioning as designed;
- e) Equipment is not operated in a reckless manner, in violation of manufacturer's guidelines or in a manner unsafe to workers, the general public, or the Transmission Provider's electric system or contrary to environmental laws, permits or regulations or without regard to defined limitations such as, flood conditions, safety inspection requirements, operating voltage, current, volt ampere reactive (VAR) loading, frequency, rotational speed, polarity, synchronization, and control system limits; and
- f) Equipment and components designed and manufactured to meet or exceed the standard of durability that is generally used for electric energy generating facilities operating in the Western United States and will function properly over the full range of ambient temperature and weather conditions reasonably

expected to occur at the Site and under both normal and emergency conditions.

158. "RA Capacity" means the qualifying and deliverable capacity of the Generating Facility for RAR purposes for the Facility Term, as determined by the ISO, or other governmental body authorized to make such determination under Applicable Law. RA Capacity encompasses all local and system RAR attributes of the capacity provided by the Generating Facility.
159. "Renewable Energy Credits" means has the meaning set forth in Public Utilities Code Section 399.12(g), as may be amended from time to time or as further defined or supplemented by Law.
160. "Required ISO Agreements" means those agreements between Seller and the ISO required from time-to-time to permit Seller to Schedule and transmit power over the ISO Grid. As of the Master Agreement Effective Date, such agreements are a Participating Generator Agreement and a Meter Service Agreement.
161. "Resource Adequacy Benefits" means the rights and privileges attached to any generating resource that satisfy any entity's resource adequacy obligations, including any local area reliability or other resource adequacy associated with the physical location or point of electric interconnection of the generating resource, as those obligations are set forth in any Resource Adequacy Rulings, to the extent attributed to or associated with the Generating Facility and any electric energy produced therewith during the Facility Term.
162. "Resource Adequacy Requirements" or "RAR" has the meaning set forth in the Resource Adequacy Rulings.
163. "Resource Adequacy Rulings" means CPUC Decisions 04-01-050, 04-10-035, 05-10-042, 06-06-064, 06-07-031, and any subsequent CPUC ruling or decision in connection with resource adequacy, or any other resource adequacy laws, rules or regulations enacted, adopted or promulgated by any applicable Governmental Authority, as such decisions, rulings, laws, rules or regulations may be amended or modified from time-to-time during the Facility Term.
164. "Resource Sale" has the meaning set forth in Section 2.05(b)(i)(2).
165. "Right of First Offer" means SCE's right of first offer and related rights to purchase with regards to any electric energy, Green Attributes, Capacity Attributes and Resource Adequacy Benefits in accordance with Section 2.05(b).
166. "RPS Legislation" means the State of California Renewables Portfolio Standard Program, as codified at California Public Utilities Code Section 399.11, *et seq.*
167. "S&P" means the Standard & Poor's Rating Group.

The contents of this document are subject to restrictions on disclosure as set forth herein.

168. "SC Schedules" means the amounts initially submitted to the ISO by Seller's Scheduling Coordinator of expected electric energy that Seller expects to deliver to SCE in each hour.
169. "SCE" has the meaning set forth in the Preamble.
170. "SCE Mitigation Rights" has the meaning set forth in Section 11.04(a).
171. "SCE Penalty" means the amount charged to Seller by SCE, in accordance with Exhibit R, for hours in a calendar month when Seller does not accurately provide availability information as set forth in Exhibit Q.
172. "SCE's Projected Energy Forecast" has the meaning set forth in Exhibit Q.
173. "Schedule," "Scheduled" or "Scheduling" means, if SCE is not acting as Seller's Scheduling Coordinator, the action of Seller and SCE, or their designated representatives, including any third party provider of scheduling services, if applicable, of notifying, requesting, and confirming to each other or to the ISO, as appropriate, the ISO Approved Quantity of electric energy from the Generating Facility being delivered by Seller to SCE in the form of Scheduling Coordinator Trades for any given day, hour, or relevant period at the Delivery Point, all in accordance with the provisions of Section 3.19(a). "Schedule," "Scheduled" or "Scheduling" means, if SCE is acting as Seller's Scheduling Coordinator, the action of SCE in submitting the SC Schedules to the ISO and receiving the final schedules from the ISO.
174. "Scheduled Amounts" means the Scheduled quantity, expressed in kWh, of electric energy from the Generating Facility (including ISO imbalance energy, if any) in the form of Scheduling Coordinator Trades confirmed to SCE on any given day, hour, or relevant period at the Delivery Point.
175. "Scheduling Coordinator" or "SC" means an entity certified by the ISO for the purposes of undertaking the functions specified by ISO Tariff Section 2.2.6, as amended by FERC from time-to-time.
176. "Scheduling Coordinator Trades" or "SC-to-SC Trades" means Scheduling Coordinator to Scheduling Coordinator trades of electric energy from the Generating Facility by Seller, or Seller's authorized agent, to SCE in accordance with the ISO Tariff.
177. "Secured Interests" has the meaning set forth in Section 8.04(a).
178. "Security Documents" has the meaning set forth in Section 8.04(a).
179. "Security Interest" has the meaning set forth in Section 8.03.
180. "Seller" has the meaning set forth in the Preamble.

The contents of this document are subject to restrictions on disclosure as set forth herein.

181. "Seller's Actual Revenue" has the meaning set forth in Exhibit O.
182. "Seller's Adjusted Revenue" has the meaning set forth in Exhibit O.
183. "Seller's Annual Availability Obligation" means the minimum Wind Turbine availability that Seller is required to maintain in any of the first ten Facility Term Years, which is that (a) the Actual Generating Facility Annual Availability for the Facility Term Year, in percent, must be equal to or greater than (b) eighty-five percent (85%).
184. "Seller's Annual Energy Obligation" means the minimum amount of energy that Seller is required to deliver in any two (2) consecutive Facility Term Years (calculated annually on a rolling two-year basis) commencing with the second Facility Term Year, which is that (a) the Metered Amounts total for the two (2) consecutive Facility Term Years of the calculation period, in MWh, plus (b) the sum of all Lost Output during the two (2) consecutive Facility Term Years of the calculation period, in MWh, must be equal to or greater than (c) 1.4 multiplied by (d) the Estimated Annual Production, in MWh.
185. "Seller's Annual Shortfall Payment" means the dollar amount calculated as set forth in Exhibit F.
186. "Seller's *First* Long Term Availability Guarantee Period" means the period that begins on the first day of the first Facility Term Year and ends on the last day of the fifth Facility Term Year.
187. "Sellers Long Term Availability Shortfall Payment" means the dollar amount calculated as set forth in Exhibit O.
188. "Seller's *Second* Long Term Availability Guarantee Period" means the period that begins on the first day of the sixth Facility Term Year and ends on the last day of the tenth Facility Term Year.
189. "Seller's Long Term Availability Obligation" means the minimum Wind Turbine availability that Seller is required to maintain in each of Seller's *First* Long Term Availability Guarantee Period and Seller's *Second* Long Term Availability Guarantee Period, which is that (a) the Actual Generating Facility Long Term Availability for each of Seller's *First* Long Term Availability Guarantee Period and Seller's *Second* Long Term Availability Guarantee Period, in percent, must be equal to or greater than (b) ninety percent (90%).
190. "Senior Lender" has the meaning set forth in the Subordination Agreement.
191. "Senior Loan" has the meaning set forth in the Subordination Agreement.

192. "Settlement Interval" means any one of the six ten (10) minute time intervals beginning on any hour and ending on the next hour (e.g. 12:00 to 12:10, 12:10 to 12:20, etc.).
193. "Simple Interest Payment" means a dollar amount calculated by *multiplying* the:
- a) Dollar amount on which the Simple Interest Payment is based; *times*
 - b) Federal Funds Effective Rate or Interest Rate as applicable; *times*
 - c) The result of *dividing* the number of days in the calculation period by 360.
194. "Site" means the real property on which the Generating Facility is, or will be located, as further described in Section 1.01(b) and Exhibit 1 to the Final Notice to Proceed for the Generating Facility, attached hereto as Exhibit B, or as adjusted in accordance with Section 3.08, and shall also include any easements, right-of-ways or contractual rights held or to be held by Seller for transmission lines and/or roadways servicing such Site or the Generating Facility located (or to be located) thereon.
195. "Site Control" has the meaning set forth in Section 3.07(a).
196. "Startup Period" has the meaning set forth in Section 3.19(b)(ii)(1).
197. "Station Use" means the electric energy produced by the Generating Facility that is either:
- a) Used within the Generating Facility to power the lights, motors, control systems and other electrical loads that are necessary for Operation; or
 - b) Consumed within the Generating Facility's electric energy distribution system as losses.
198. "Subordination Agreement" means an Intercreditor and Subordination Agreement in the form of the attached Exhibit U, together with such commercially reasonable changes requested by Lender and reasonably acceptable to SCE and Seller.
199. "Supplemental Lost Output" has the meaning set forth in Section 3.18(b).
200. "Supplemental Lost Output Report" has the meaning set forth in Section 3.18(b).
201. "Supply Plan" means the supply plans, or similar or successor filings, that each Scheduling Coordinator representing RA Capacity submits to the ISO, local regulatory authority, or other governmental body, pursuant to Applicable Law, in order for that RA Capacity to count for RAR showings.
202. "System Impact Study" has the meaning set forth in the ISO Tariff.

203. "Termination Payment" has the meaning set forth in Section 6.03.
204. "Tax Equity Provider" means any Person(s) or successor(s) in interest or assignees, other than Terra-Gen or an Affiliate of Terra-Gen, that provide(s) financing or refinancing for the Generating Facility to Seller (or an Affiliate of Seller) and whose return is substantially derived from tax attributes, including interest deductions, accelerated depreciation and PTCs, in respect of the ownership interest in the Generating Facility.
205. "Terra-Gen" means Terra-Gen Power, LLC, a Delaware limited liability company, including its successors in interest, or any entity that acquires all or substantially all of the assets of Terra-Gen Power, LLC or any such successor in interest.
206. "Terra-Gen Controlled" means, with respect to a Person: (a) either (i) that 100% of the equity interests of the Person are directly or indirectly owned by Terra-Gen, and/or one or more of Terra-Gen's Affiliates, or a combination thereof, or (ii) that (A) more than 50% of the equity interests of the Person are directly or indirectly owned by Terra-Gen, and/or one or more of Terra-Gen's Affiliates, or a combination thereof, and (B) the remaining equity interests are owned by one or more Persons other than an investor-owned utility in the United States of America and acceptable to SCE in its reasonable discretion, and (b) the Person is Controlled by Terra-Gen or one or more of its Affiliates.
207. "TLF" means a measure of all net electrical losses, as determined by the Transmission Provider, associated with the transmission of electric energy through the electric system from the high voltage side of the Generating Facility's substation bus bar to the interface with the ISO Grid, also known as the transmission loss factor.
208. "TMM(s)" means the tie meter multipliers as determined by the ISO representing the calculation of all electrical losses over the ISO Grid associated with the transmission of electric energy delivered at an ISO Control Area boundary, which values are, as of the Master Agreement Effective Date, posted by the ISO on its website. The values used in this Power Purchase Agreement will be those appearing on the ISO website on the third (3rd) Business Day of the calendar month following the month for which such values are being applied.
209. "TOD Period(s)" means the time of delivery period(s) set forth in Exhibit K.
210. "TOD Period Energy Payment" has the meaning set forth in Section 4.02(a).
211. "Transmission Provider" means any entity or entities responsible for the interconnection of the Generating Facility with a Control Area or transmitting the Metered Amounts on behalf of Seller from the Generating Facility to the Delivery Point.
212. "Unincluded Capacity" has the meaning set forth in Section 3.04(f).

The contents of this document are subject to restrictions on disclosure as set forth herein.

-
213. "Under-Scheduling Settlement Interval Adjustment Amount" means the amount calculated as set forth in Exhibit E.
214. "Web Client" has the meaning set forth in Section 3.10(d)(i).
215. "WECC" means the Western Electricity Coordinating Council, the regional reliability council for the Western United States and Canada.
216. "Wind Turbine" means a wind turbine generator installed on the Site as part of the Generating Facility including any replacements or substitutes therefore.
217. "Wind Turbine Manufacturer's Power Curve" means a Wind Turbine manufacturer's table that estimates the electric energy generating capacity for one Wind Turbine of a specified model based upon wind speeds and other Site specific conditions.

**** End of EXHIBIT A ****

EXHIBIT B

Final Notice to Proceed

The contents of this document are subject to restrictions on disclosure as set forth herein.

EXHIBIT B

Final Notice to Proceed

Alta Wind VI, LLC

February 5, 2010

1. Seller.
Alta Wind VI, LLC.
2. Generating Facility.
 - (a) Name: Alta Wind VI Energy Center.
 - (b) Location of Site: Mojave, Kern County, California.
 - (c) Nameplate Contract Capacity: 150 MW.
 - (d) Expected Initial Operation Date: January 1, 2012.
 - (e) Expected Construction Commencement Date: March 15, 2011.
3. Proposed Final Energy Price.
 - (a) Applicable Benchmark Bid Price: Seventy five dollars and eighteen cents (\$75.18) per MWh.
 - (b) Percent Change in Wind Turbine Cost: +79.7%.
 - (c) Absolute Change in Interest Rate: (1.868)%.
 - (d) Energy Price Adjustment: 171.90% (from Adjustment Chart in Agreement, Exhibit H).
 - (e) Final Energy Price: One hundred twenty one dollars and twenty-six cents (\$121.26) [revised to Energy Price Maximum from calculated Final Energy Price of 129.24 in Final Notice to Proceed dated December 22, 2009].
 - (f) Energy Price Minimum and Energy Price Maximum: (calculated using current MPR)

<i>Calendar Year of Installed Capacity (MW)</i>	<i>Energy Price Minimum (\$ per MWh)</i>	<i>Energy Price Maximum (\$ per MWh)</i>
2007	N/A	N/A
2008	N/A	N/A
2009	\$33.50	\$111.26
2010	\$32.70	\$113.90
2011	\$31.16	\$117.30
2012	\$29.10	\$121.26
2013	\$26.99	\$125.27

The contents of this document are subject to restrictions on disclosure as set forth herein.

Southern California Edison

Confidential Information

2014	\$25.23	\$128.97
2015	\$23.26	\$132.90
2016	\$21.10	\$137.06
2017	\$18.76	\$141.44
2018	\$16.21	\$146.03
2019	\$13.52	\$150.80
2020	\$10.66	\$155.78

The contents of this document are subject to restrictions on disclosure as set forth herein.

EXHIBIT 1 TO FINAL NOTICE TO PROCEED

Generating Facility and Site Description

1. Generating Facility Description.

A 150MW generating facility consisting of 50 Vestas 3.0MW wind turbines, a transforming substation, and underground and overhead collection system and transmission lines, delivering electricity at 230kV to the Alta 4 (CPC West) point of interconnection at SCE's Windhub substation.

A site map with plan drawing is attached.

A one-line diagram is attached.

2. Site Description.

The Alta Wind VI Energy Center site will be located on sections 13, 14, 23, 24, 25, 26, 35, and 36 in Township 11N, Range 14W, SBB&M in Kern County, CA.

A site map is attached.

Attachment: Site Map
(Subject to change)

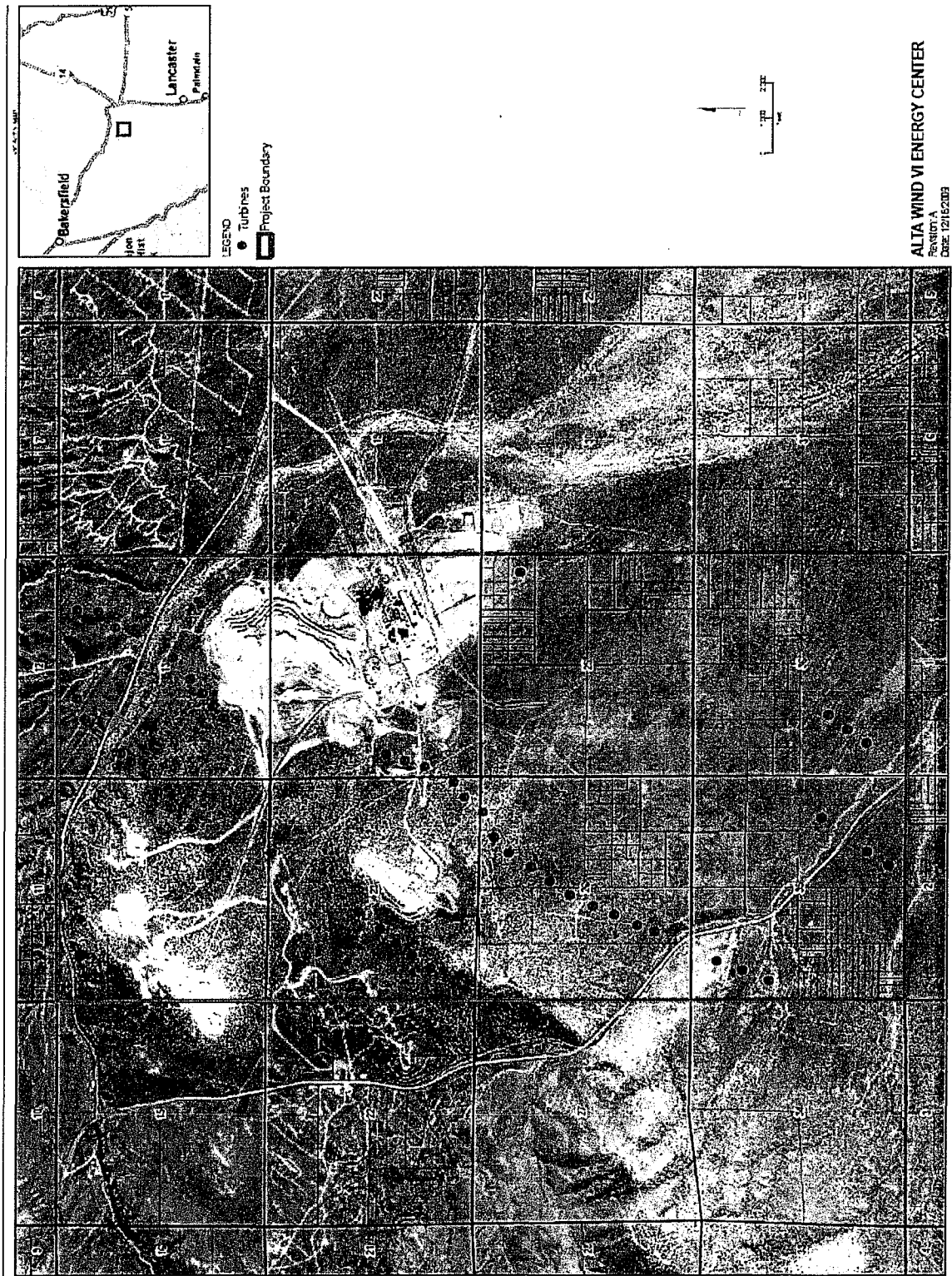

The contents of this document are subject to restrictions on disclosure as set forth herein.

Attachment: One-line Diagram
(Subject to change)

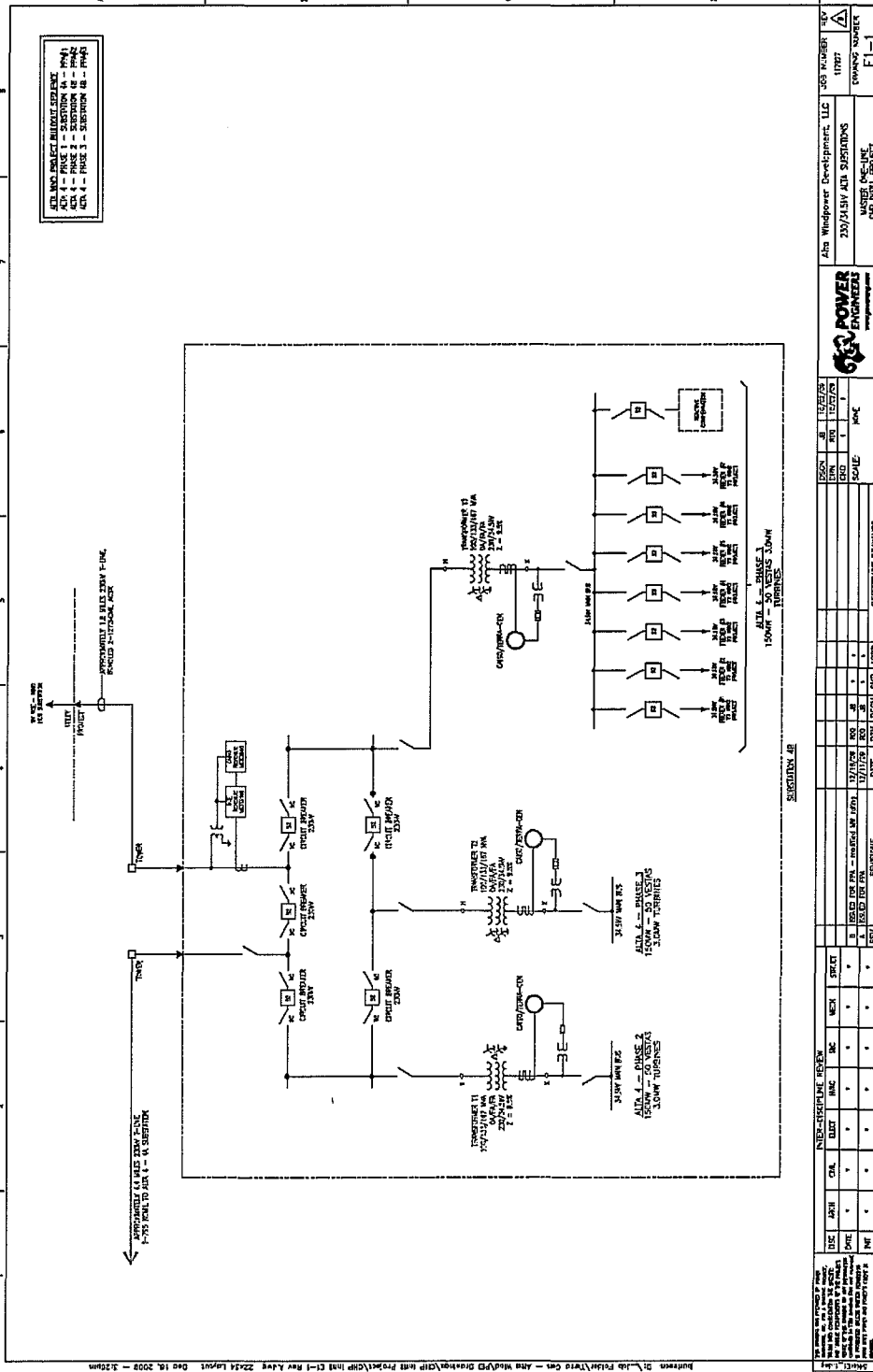

DATE	BY	REVISIONS	DATE	BY	REVISIONS
10/15/09	10/15/09
10/15/09	10/15/09
10/15/09	10/15/09

15KV/30KV/30MVA	15KV/30KV/30MVA	15KV/30KV/30MVA	15KV/30KV/30MVA	15KV/30KV/30MVA	15KV/30KV/30MVA
15KV/30KV/30MVA	15KV/30KV/30MVA	15KV/30KV/30MVA	15KV/30KV/30MVA	15KV/30KV/30MVA	15KV/30KV/30MVA
15KV/30KV/30MVA	15KV/30KV/30MVA	15KV/30KV/30MVA	15KV/30KV/30MVA	15KV/30KV/30MVA	15KV/30KV/30MVA
15KV/30KV/30MVA	15KV/30KV/30MVA	15KV/30KV/30MVA	15KV/30KV/30MVA	15KV/30KV/30MVA	15KV/30KV/30MVA
15KV/30KV/30MVA	15KV/30KV/30MVA	15KV/30KV/30MVA	15KV/30KV/30MVA	15KV/30KV/30MVA	15KV/30KV/30MVA
15KV/30KV/30MVA	15KV/30KV/30MVA	15KV/30KV/30MVA	15KV/30KV/30MVA	15KV/30KV/30MVA	15KV/30KV/30MVA

*** End of EXHIBIT B ***

The contents of this document are subject to restrictions on disclosure as set forth herein.

EXHIBIT C

Notice List

The contents of this document are subject to restrictions on disclosure as set forth herein.

EXHIBIT C

Notice List

Name: Alta Wind VI, LLC ("Seller")	Name: SOUTHERN CALIFORNIA EDISON COMPANY ("SCE")
All Notices are deemed provided in accordance with Section 10.8 if made to the address and/or facsimile numbers provided below:	All Notices are deemed provided in accordance with Section 10.8 if made to the address and/or facsimile numbers provided below:
Contract Sponsor: Attn: [REDACTED] Street: [REDACTED] City: [REDACTED] Phone: [REDACTED] Facsimile: [REDACTED]	Contract Sponsor: Attn: [REDACTED] Street: [REDACTED] City: [REDACTED] Phone: [REDACTED] Facsimile: [REDACTED]
Reference Numbers: Duns: [REDACTED] Federal Tax ID Number: [REDACTED]	Reference Numbers: Duns: [REDACTED] Federal Tax ID Number: [REDACTED]
Contract Administration: Attn: [REDACTED] Phone: [REDACTED] Facsimile: [REDACTED] Email: [REDACTED]	Contract Administration: Attn: [REDACTED] Phone: [REDACTED] Facsimile: [REDACTED] Email: [REDACTED]

Name: Alta Wind VI, LLC ("Seller")	Name: SOUTHERN CALIFORNIA EDISON COMPANY ("SCE")
Scheduling: Attn: [to be provided at later date] Phone: Facsimile:	Generation Operations Center: Phone: [REDACTED] Phone: [REDACTED]
Day-Ahead Scheduling: Phone: [to be provided at later date]	Day-Ahead Scheduling: <u>Manager.</u> Attn: [REDACTED] Phone: Facsimile: <u>Scheduling Desk.</u> Phone: [REDACTED] Backup: Fax: Email: [REDACTED]
Real-Time Scheduling: Phone: [to be provided at later date]	Real-Time Scheduling: <u>Manager.</u> Attn: [REDACTED] Phone: [REDACTED] Facsimile: [REDACTED] <u>Operations Desk.</u> Phone: [REDACTED] Back-up: [REDACTED] Fax: [REDACTED] Email: [REDACTED]
Outage Scheduling: Phone: [to be provided at later date]	Outage Scheduling: Phone: [REDACTED]

Name: Alta Wind VI, LLC ("Seller")	Name: SOUTHERN CALIFORNIA EDISON COMPANY ("SCE")
Invoices: Attn: [REDACTED] Phone: [REDACTED] Facsimile: [REDACTED] Email: [REDACTED]	Payment Statements: Attn: [REDACTED] Phone: [REDACTED] Facsimile: [REDACTED] Email: [REDACTED]
Payments: Attn: [REDACTED] Phone: [REDACTED] Facsimile: [REDACTED] Email: [REDACTED]	Payments: Attn: [REDACTED] Phone: [REDACTED] Facsimile: [REDACTED] Email: [REDACTED]
Wire Transfer: BNK: [to be provided at later date] ABA: ACCT:	Wire Transfer: BNK: [REDACTED] ABA: [REDACTED] ACCT: [REDACTED]
Credit and Collections: Attn: [REDACTED] Phone: [REDACTED] Facsimile: [REDACTED] Email: [REDACTED]	Manager of Credit and Collateral: Attn: [REDACTED] Phone: [REDACTED] Facsimile: [REDACTED]
With additional Notices of an Event of Default or Potential Event of Default to: Attn: [REDACTED] Phone: Facsimile: Email: [REDACTED]	With additional Notices of an Event of Default or Potential Event of Default to: Attn: [REDACTED] Phone: Facsimile: [REDACTED]

Name: Alta Wind VI, LLC ("Seller")	Name: SOUTHERN CALIFORNIA EDISON COMPANY ("SCE")
Guarantor: Attn: [to be provided at later date] Phone: Facsimile: Email:	
Lender: Attn: [to be provided at later date] Phone: Facsimile: Email:	
	QF Efficiency Data: Attn: [REDACTED] Phone: [REDACTED] Facsimile: [REDACTED] Email: [REDACTED]

*** End of EXHIBIT C***

EXHIBIT D

*Scheduling Requirements and Procedures Applicable When SCE is Not Seller's
Scheduling Coordinator*

EXHIBIT D*Scheduling Requirements And Procedures Applicable When SCE is Not Seller's Scheduling Coordinator*1. Introduction.

The Parties shall abide by the Scheduling requirements and procedures described below and shall make reasonable changes to these requirements and procedures from time-to-time, as necessary to:

- (a) Comply with ISO Tariff changes;
- (b) Accommodate changes to their respective generation technology and organizational structure; and
- (c) Address changes in the operating and scheduling procedures of Seller's Scheduling Coordinator (to the extent those changes are consistent with industry standards or otherwise reasonably acceptable to SCE), SCE and the ISO, including, but not limited to, automated schedule and outage submissions.

2. Procedures That Apply Regardless of Generating Facility PIRP Status or Participation.(a) Introduction.

These procedures apply to the Generating Facility regardless of PIRP status or the Generating Facility's participation in the PIRP. In general, Generating Facilities must meet all of the following requirements before Scheduling with SCE.

(b) Information Exchange.

Seller shall provide to SCE information regarding Seller's Scheduling Coordinator ("SC") at least thirty (30) days before the expected commencement of the Facility Term, or any change in Seller's SC. This information shall include the:

- (i) SC's name.
- (ii) SC's SCID as assigned by the ISO (e.g., SCE's ID is "SCE1").

Seller's SC and SCE shall then exchange their appropriate contact information including: names of authorized scheduling personnel, phone number, FAX numbers and e-mail addresses.

The contents of this document are subject to restrictions on disclosure as set forth herein.

(c) SC-to-SC Trade Procedures.

Scheduling between the Parties will be via Scheduling Coordinator Trades ("SC-to-SC Trades"), as specified below:

- (i) SC-to-SC Trades will be communicated to SCE using the Web Client. If the Web Client is unavailable then, SCE requires telephonic notification of all Day-Ahead and Hour-Ahead Schedules, followed by written electronic confirmation (e-mail preferred, FAX accepted).
- (ii) Upon implementation of MRTU, if Seller is not in PIRP or a successor program or if Seller is in PIRP and PIRP provides for monthly netting for Day-Ahead Schedules in the same manner as of the Master Agreement Effective Date for Hour-Ahead Schedules, Day-Ahead Schedules shall be communicated to SCE's Day-Ahead Group no later than 8:30 a.m. the day prior to the effective date of the Schedule.
- (iii) Hour-Ahead Schedules shall be communicated to SCE's Real-Time Group no later than (a) one half (½) hour prior to the ISO's Hour-Ahead scheduling deadline or (b) as soon as practicable if Seller is in PIRP.
- (iv) The SC-to-SC Trade quantity must match the Generating Facility Schedule.

3. Procedures That Apply After the Generating Facility Has Met All Requirements for PIRP Monthly Balancing.

(a) Introduction.

These procedures apply to wind powered Generating Facilities that have met all ISO requirements for monthly balancing as stated in the ISO Tariff and the ISO Eligible Intermittent Resources Protocol ("EIRP"), or its successor protocol.

(b) Advisory Month-Ahead Forecast.

Seller shall provide SCE an electronic file containing a non-binding rolling thirty (30) day estimate of hourly Schedules for the Generating Facility, beginning at least thirty (30) days before the expected commencement of the Facility Term. These files shall be communicated to SCE using an the Web Client. If the Web Client in unavailable then these files shall:

- (i) Be constructed using reasonable file formats, templates, and logical file-naming conventions, as agreed to by the Parties.
- (ii) Include Seller's contact information.

The contents of this document are subject to restrictions on disclosure as set forth herein.

(iii) Be sent to esmstpoutage@sce.com, with a copy to presched@sce.com, or as otherwise instructed by SCE.

(iv) Be updated by close of business each Wednesday.

(c) Communication of Day-Ahead PIRP Forecast.

Seller's SC shall communicate or make available to SCE the ISO's Day-Ahead PIRP forecast as soon as practicable after the SC extracts it from the ISO Web site, but no later than 8:30 a.m. the day prior to the effective date of the schedule change. If the ISO fails to publish a Day-Ahead Forecast prior to 8:30 am, *then* SCE and the Seller's SC will agree upon a SC-to-SC trade to act as a Schedule for Day-Ahead balancing purposes only. This forecast is non-binding and subject to change in the Hour-Ahead market.

(d) Communication of Hour-Ahead PIRP Schedule.

Seller's SC shall communicate or make available to SCE the ISO's Hour-Ahead PIRP Schedule thirty (30) minutes prior to the close of the Hour Ahead market. If the ISO fails to publish an Hour-Ahead Forecast prior to fifteen (15) minutes before the close of the Hour-Ahead market, *then* SCE and the Seller's SC will agree upon a SC-to-SC trade to act as a Schedule for Hour-Ahead balancing purposes; provided that, if the ISO subsequently publishes an Hour-Ahead Forecast, that forecast shall apply as long as the forecast is communicated to SCE prior to the close of the ISO hour-ahead scheduling timeline.

4. Procedures That Apply If the Generating Facility Has Not Met All Requirements for PIRP Monthly Balancing.

(a) Introduction.

These procedures apply to wind powered Generating Facilities before they have met all ISO requirements for monthly balancing stated in the ISO's Tariff and the EIRP (or its successor protocol) and to wind powered Generating Facilities if the PIRP (or a successor program) is not available.

(b) Advisory Month-Ahead Forecast.

Seller shall provide SCE an electronic file containing a non-binding rolling thirty (30) day estimate of hourly Schedules for the Generating Facility, beginning at least thirty (30) days before the expected commencement of the Facility Term. These files shall be communicated to SCE using the Web Client. If the Web Client is unavailable then these files shall:

- (i) Be constructed using reasonable file formats, templates, and logical file-naming conventions, as agreed to by the Parties.
 - (ii) Include Seller's contact information.
 - (iii) Be sent to esmstpoutage@sce.com, with a copy to presched@sce.com, or as otherwise instructed by SCE.
 - (iv) Be updated by close of business each Wednesday.
- (c) Small Scheduling Changes.

Seller shall limit hour-to-hour Schedule changes to no less than 250 kW.

- (d) Notification of SC-to-SC Trade Schedule Amounts.

Seller shall notify SCE in writing (e-mail or fax) of the hourly Delivered Amounts Seller has instructed its SC to schedule Day-Ahead, by the Day-Ahead notification deadline.

5. Meteorological Equipment and Reporting Requirements.

Seller, at its own expense, shall install and maintain a stand-alone meteorological station at the Generating Facility to monitor and report weather data to both the ISO and SCE (and shall continue to transmit such data to SCE if the PIRP program is discontinued and there is no ISO successor program).

The meteorological station shall be installed at least sixty (60) days before the date on which the Facility Term is expected to commence and shall be equipped with instruments and equipment typically used in the wind industry to continuously monitor weather conditions at a wind resource site.

The station shall be designed to collect and record data in accordance with ISO EIRP 4. Data reports shall be formatted in a manner consistent with the ISO requirements published on the ISO internet home page.

Telemetry equipment shall be designed to function in accordance with ISO EIRP 3. The station shall be equipped to measure and record the minimum data required by the ISO, in the manner specified by the ISO.

Seller shall submit to the ISO for review and approval and to SCE for review, its technical specification for the meteorological station along with a site plan showing the location of the station, the location of all wind turbines and the wind rose for the Site. The data from the meteorological station shall be easily readable by SCE personnel.

If the ISO or SCE reasonably concludes that the permanent meteorological station does not provide sufficient data to accurately forecast the Generating Facility's Metered Amounts, Seller shall install, at Seller's expense, one additional meteorological station at another Generating Facility location in accordance with the technical and scheduling requirements established by the ISO.

Seller shall install additional meteorological stations at the Generating Facility, as may be required by SCE, at SCE's expense; *provided that*, such station shall not interfere with the Operation of the Generating Facility.

6. Outage Scheduling Procedures.

Seller shall be responsible for all expenses and costs associated with all requirements and timelines for generation outage scheduling contained in the ISO's Scheduled and Forced Outage Procedure T-113 as posted on the ISO's website.

*** End of EXHIBIT D ***

EXHIBIT E

Payment Adjustments for Scheduling Deviations by Seller

EXHIBIT E*Payment Adjustments For Scheduling Deviations By Seller*

In accordance with the provisions of Section 4.02(b), if in any Settlement Interval, a Generating Facility's Scheduled Amounts deviate from the Generating Facility's Delivered Amounts by more than plus or minus three percent ($\pm 3\%$) of the Generating Facility's Delivered Amounts, *then* Seller shall be subject to a payment adjustment calculated by SCE in accordance with the procedures and formulae set forth below.

(1) UNDER-SCHEDULING ADJUSTMENT.

If during any Settlement Interval;

- (a) The Scheduled Amounts is less than ninety-seven percent (97%) of the Delivered Amounts, and
- (b) The Market Price is greater than the time-differentiated Energy Price payable during the Settlement Interval;

then Seller's monthly payment amount shall be reduced by each Under-Scheduling Settlement Interval Adjustment Amount calculated by the following formula:

UNDER-SCHEDULING SETTLEMENT INTERVAL ADJUSTMENT AMOUNT =

$$[[A - B] \times [D - (C \times E)]] - F$$

Where A = The Delivered Amounts in the Settlement Interval being calculated.

B = The Scheduled Amounts in the Settlement Interval being calculated.

C = Energy Price specified in Section 1.02 of this Power Purchase Agreement in \$/kWh (i.e., (\$/MWh)/1000) payable during the Settlement Interval being calculated.

D = Market Price for the Settlement Interval being calculated in \$/kWh.

E = Energy Payment Allocation Factor applicable to the Settlement Interval being calculated.

The contents of this document are subject to restrictions on disclosure as set forth herein.

F = Any uninstructed deviations penalties paid by Seller to the ISO applicable to the Settlement Interval being calculated.

No under-scheduling adjustment shall be assessed against Seller for a Settlement Interval in which the Scheduled Amounts is less than the Delivered Amounts if, during such Settlement Interval, the Market Price is equal to or less than the time-differentiated Energy Price payable during the Settlement Interval.

(2) OVER-SCHEDULING ADJUSTMENT.

If during any Settlement Interval;

- (a) The Scheduled Amounts is greater than one hundred three percent (103%) of the Delivered Amounts, and
- (b) The Market Price is less than the time-differentiated Energy Price payable during the Settlement Interval;

then Seller's monthly payment amount shall be reduced by each Over-Scheduling Settlement Interval Adjustment Amount calculated by the following formula:

OVER-SCHEDULING SETTLEMENT INTERVAL ADJUSTMENT AMOUNT =

$$[[B - A] \times [(C \times E) - D]] - F$$

Where A = The Delivered Amounts in the Settlement Interval being calculated.

B = The Scheduled Amounts in the Settlement Interval being calculated.

C = Energy Price specified in Section 1.02 of this Power Purchase Agreement in \$/kWh (i.e., (\$/MWh)/1000) payable during the Settlement Interval being calculated.

D = Market Price for the Settlement Interval being calculated in \$/kWh.

E = Energy Payment Allocation Factor applicable to the Settlement Interval being calculated.

F = Any uninstructed deviations penalties paid by Seller to the ISO applicable to the Settlement Interval being calculated.

The contents of this document are subject to restrictions on disclosure as set forth herein.

No over-scheduling adjustment shall be assessed against Seller for a Settlement Interval in which the Scheduled Amounts is greater than the Delivered Amounts if, during such Settlement Interval, the Market Price is greater than or equal to the time-differentiated Energy Price payable during the Settlement Interval.

*** *End of EXHIBIT E* ***

EXHIBIT F

Seller's Annual Shortfall Payment

EXHIBIT F

Seller's Annual Shortfall Payment

1) Introduction.

Seller's Annual Shortfall Payment shall be determined at the end of each Facility Term Year in accordance with the requirements set forth in Section 3.05 and the following formulas.

2) SELLER'S ANNUAL SHORTFALL PAYMENT, in dollars
equals the greater of:

- a) Seller's Annual Energy Delivery Obligation Shortfall Payment, as calculated in Item #3 of this Exhibit F for all the two consecutive Facility Term Year periods during the Facility Term, in dollars. Therefore, the first calculation of this amount shall be at the end of the second Facility Term Year; and
- b) Seller's Annual Availability Shortfall Payment, as calculated in Item #4 of this Exhibit F for each of the first ten (10) Facility Term Years, in dollars.

3) SELLER'S ANNUAL ENERGY DELIVERY OBLIGATION SHORTFALL PAYMENT, in dollars, *equals the greater of zero dollars (\$0) and the result of:*

$$= [(A_{F1} \times B_{F1}) - C_{F1} - D_{F1}] \times E_{F1} - F_{F1}$$

Where:

A_{F1} = One hundred forty percent (140%).

B_{F1} = The Estimated Annual Production, in MWh.

C_{F1} = The Metered Amounts total for the two (2) year consecutive Facility Term Years of the calculation period, in MWh.

D_{F1} = The sum of all Lost Output during the two (2) consecutive Facility Term Years of the calculation period, in MWh.

E_{F1} = *The lesser of:*

a) Fifty dollars (\$50.00) per MWh; and

b) *The greater of:*

i) Twenty dollars (\$20.00) per MWh; and

The contents of this document are subject to restrictions on disclosure as set forth herein.

ii) *The result of:*

$$A_{F2} - B_{F2}$$

Where:

A_{F2} = The simple average of the Market Price for all Settlement Intervals during the two (2) consecutive Facility Term Year calculation period, in dollars per MWh.

B_{F2} = The Energy Price, in dollars per MWh.

F_{F1} = Seller's Annual Shortfall Payment for the previous Facility Term Year, in dollars.

4) SELLER'S ANNUAL AVAILABILITY SHORTFALL PAYMENT, in MWh, equals the greater of zero dollars (\$0) and the result of:

$$= (A_{F3} - B_{F3}) \times C_{F3} \times D_{F3}$$

Where:

A_{F3} = Eighty-five percent (85%).

B_{F3} = The Actual Generating Facility Annual Availability for the current Facility Term Year, in percent.

C_{F3} = The Estimated Annual Production, in MWh.

D_{F3} = *The lesser of:*

a) Ten dollar (\$10.00) per MWh; and

b) *The greater of:*

i) Zero dollars (\$0.00) per MWh; and

ii) *The result of:*

$$A_{F4} - B_{F4}$$

Where:

A_{F4} = The simple average of the Market Price for all Settlement Intervals during the Facility Term Year calculation period, in dollars per MWh.

B_{F4} = The Energy Price, in dollars per MWh.

**** End of EXHIBIT F ****

EXHIBIT G

Seller's Milestone Schedule

The contents of this document are subject to restrictions on disclosure as set forth herein.

EXHIBIT G*Seller's Milestone Schedule*

<i>No.</i>	<i>Date</i>	<i>Milestones</i>
1	Completed	Submits interconnection application.
2	N/A	Files any land applications.
3	6/30/2010	Files the principal land use Permit application.
4	6/30/2011	Files a CEC Certification and Verification application.
5	6/30/2010	Files an Authority to Construct permit application.
6	Completed	Receives a completed System Impact Study.
7	2/14/2011	Obtains control of all lands and rights-of-way comprising the Site.
8	Completed	Receives a completed Interconnection Facility Study.
9	3/15/2010	Executes a Large Generator Interconnection Agreement or other similar agreement(s).
10	5/15/2010	Receives FERC acceptance of Large Generator Interconnection Agreement or other similar agreement(s).
11	2/14/2011	Receives the principal land use Permit.
12	2/14/2011	Receives an Authority to Construct permit.
13	8/29/2011	Receives CEC Certification and Verification.
14	2/14/2011	Executes an Engineering, Procurement and Construction ("EPC") contract.
15	3/15/2011	Completes Financing.
16	3/15/2011	Receives the Final Wind Report.
17	3/15/2011	Begins construction of the Generating Facility.
18	10/13/2011	Begins startup activities.
19	1/1/2012	Achieves Initial Operation.
20	1/31/2012	Demonstrates the Nameplate Contract Capacity.

*** End of EXHIBIT G ***

The contents of this document are subject to restrictions on disclosure as set forth herein.

EXHIBIT H

Milestone Progress Reporting Form

EXHIBIT H*Milestone Progress Reporting Form*

Seller shall prepare a written report each month on its progress relative to the development construction and startup of the Generating Facility and the Milestone Schedule. The report shall be sent via email in the form of a single Adobe Acrobat file or facsimile to SCE's Contract Administrator, as noted in Exhibit C, on the fifth (5th) Business Day of each month.

Seller's Milestone Progress Reporting requirement shall begin on the first day of the second full calendar month after the Power Purchase Agreement Effective Date of this Power Purchase Agreement and shall end when the Nameplate Contract Capacity of the Generating Facility is demonstrated pursuant to Section 3.04.

Each Milestone Progress Report shall include the following items:

1. Cover page.
2. Brief Generating Facility description.
3. Site plan of the Generating Facility.
4. Description of any planned changes to the Generating Facility and Site Description in Exhibit 1 to the Final Notice to Proceed for the Generating Facility, attached hereto as Exhibit B.
5. Bar chart schedule showing progress on achieving the Milestone Schedule.
6. PERT or GANT chart showing critical path schedule of major items and activities.
7. Summary of activities during the previous month.
8. Forecast of activities scheduled for the current month.
9. Written description about the progress relative to Seller's Milestone Schedule.
10. List of issues that could potentially impact Seller's Milestone Schedule.
11. Enumeration and schedule of any support or actions requested of SCE.
12. Progress and schedule of all agreements, contracts, permits, approvals, technical studies, financing agreements and major equipment purchase orders showing the start dates, completion dates, and completion percentages.
13. A status report of start-up activities including a forecast of activities ongoing and after start-up, a report on Generating Facility performance including performance projections for the next twelve (12) months.

The contents of this document are subject to restrictions on disclosure as set forth herein.

**** End of EXHIBIT H ****

EXHIBIT I

Form of Guaranty Agreement

The contents of this document are subject to restrictions on disclosure as set forth herein.

EXHIBIT I*Form of Guaranty Agreement*1. Guaranty.

For valuable consideration, [Guarantor's legal name], [legal status] ("Guarantor") unconditionally and irrevocably guarantees payment to Southern California Edison Company, a California corporation ("Beneficiary"), its successors and assigns, of all amounts owed to Beneficiary by [Seller's legal name], [legal status] ("Principal") under that certain Generating Facility Power Purchase and Sale Agreement between Beneficiary and Principal dated [date], as amended from time-to-time ("Agreement") (said amounts are hereinafter referred to as the "Obligations"). Initially capitalized words that are used but not otherwise defined herein shall have the meanings given them in the Agreement. Upon the failure or refusal by Principal to pay all or any portion of the Obligations, the Beneficiary may make a demand upon the Guarantor. Such demand shall be in writing and shall state the amount Principal has failed to pay and an explanation of why such payment is due, with a specific statement that Beneficiary is calling upon Guarantor to pay under this guaranty ("Guaranty"). Guarantor shall promptly, but in no event less than ten (10) Business Days following demand by Beneficiary, pay such Obligations in immediately available funds. A payment demand satisfying the foregoing requirements shall be deemed sufficient notice to Guarantor that it must pay the Obligations. Other than such demand for payment, the Guarantor hereby expressly waives all notices between the Beneficiary and the Principal including without limitation all notices with respect to the Agreement and this Guaranty, and any notice of credits extended and sales made by the Beneficiary to the Principal, and all other notices whatsoever. The liability of Guarantor hereunder is a continuing guaranty of payment when any amount is owing without regard to whether recovery may be or has become barred by any statute of limitations or otherwise may be unenforceable.

2. Guaranty Limit.

Subject only to Paragraph 12, notwithstanding any other term or provision hereof to the contrary, the liability of Guarantor hereunder shall not exceed \$ _____ in the aggregate, which amount shall include all interest that has accrued on any amount owed hereunder.

3. Guaranty Absolute.

Guarantor agrees that its obligations under this Guaranty are irrevocable, absolute, independent and unconditional and shall not be affected by any circumstance which constitutes a legal or equitable discharge of a guarantor or surety, other than satisfaction of the Obligations. In furtherance of the foregoing and without limiting the generality thereof, Guarantor agrees as follows:

The contents of this document are subject to restrictions on disclosure as set forth herein.

- (a) The liability of Guarantor under this Guaranty is a guaranty of payment and not of collectibility, and is not conditional or contingent upon the genuineness, validity, regularity or enforceability of the Agreement or the pursuit by Beneficiary of any remedies which it now has or may hereafter have under the Agreement;
- (b) Beneficiary may enforce this Guaranty upon the occurrence of a default by Principal under the Agreement notwithstanding the existence of a dispute between Beneficiary and Principal with respect to the existence of the default;
- (c) The obligations of Guarantor under this Guaranty are independent of the obligations of Principal under the Agreement and a separate action or actions may be brought and prosecuted against Guarantor whether or not any action is brought against Principal or any other guarantors and whether or not Principal is joined in any such action or actions;
- (d) Guarantor's payment of a portion, but not all, of the Obligations shall in no way limit, affect, modify or abridge Guarantor's liability for that portion of the Obligations which is not paid. Without in any way limiting the generality of the foregoing, if Beneficiary is awarded a judgment in any suit brought to enforce a portion of the Obligations, such judgment shall not be deemed to release Guarantor from its covenant to pay that portion of the Obligations which is not the subject of such suit;
- (e) Beneficiary may, at its election, foreclose on any security held by Beneficiary, whether or not the means of foreclosure is commercially reasonable, or exercise any other right or remedy available to Beneficiary without affecting or impairing in any way the liability of Guarantor under this Guaranty, except to the extent the amount(s) owed to Beneficiary by Principal have been paid; and
- (f) Guarantor shall continue to be liable under this Guaranty and the provisions hereof shall remain in full force and effect notwithstanding:
 - (i) Any modification, amendment, supplement, extension, agreement or stipulation between Principal and Beneficiary or their respective successors and assigns, with respect to the Agreement or the obligations encompassed thereby;
 - (ii) Beneficiary's waiver of or failure to enforce any of the terms, covenants or conditions contained in the Agreement;
 - (iii) Any release of any other guarantor from any liability with respect to the Obligations or any portion thereof;

- (iv) Any release, compromise or subordination of any real or personal property then held by Beneficiary as security for the performance of the Obligations or any portion thereof, or any substitution with respect thereto;
- (v) Beneficiary's acceptance and/or enforcement of, or failure to enforce, any other guaranties;
- (vi) Beneficiary's exercise of any other rights available to it under the Agreement;
- (vii) Beneficiary's consent to the change, reorganization or termination of the corporate structure or existence of the Principal and to any corresponding restructuring of the Obligations;
- (viii) Any failure to perfect or continue perfection of a security interest in any collateral that secures the Obligations;
- (ix) Any defenses, setoffs or counterclaims that Principal may allege or assert against Beneficiary with respect to the Obligations, including, without limitation, failure of consideration, breach of warranty, statute of frauds, statute of limitations and accord and satisfaction; and
- (x) Any other act or thing or omission, or delay to do any other act or thing that might in any manner or to any extent vary the risk of Guarantor as an obligor with respect to the Obligations.

4. Termination; Reinstatement.

- (a) The term of this Guaranty is continuous until the date on which the Obligations have been performed or paid in full.
- (b) Notwithstanding the provisions of Paragraph 4(a) hereof, this Guaranty shall be reinstated if at any time following the termination of this Guaranty under Paragraph 4(a) hereof, any payment by Guarantor under this Guaranty or pursuant hereto is rescinded or must otherwise be returned by the Beneficiary or other person upon the insolvency, bankruptcy, reorganization, dissolution or liquidation of Principal, Guarantor or otherwise, and is so rescinded or returned to the party or parties making such payment, all as though such payment had not been made. Such period of reinstatement shall continue until satisfaction of the conditions contained in, and shall continue to be subject to, the provisions of Paragraph 4(a) hereof. If all or any portion of the Obligations are paid by Principal, the obligations of Guarantor hereunder shall continue and remain in full force and effect or be reinstated, as the case may be, in the event that all or any part of such payment(s) are rescinded or recovered directly or indirectly from Beneficiary as a preference, fraudulent

The contents of this document are subject to restrictions on disclosure as set forth herein.

transfer or otherwise, and any such payments which are so rescinded or recovered shall constitute Obligations for all purposes under this Guaranty.

5. Bankruptcy; Post-Petition Interest.

- (a) The obligations of Guarantor under this Guaranty shall not be reduced, limited, impaired, discharged, deferred, suspended or terminated by any proceeding, voluntary or involuntary, involving the bankruptcy, insolvency, receivership, reorganization, liquidation or arrangement of the Principal or by any defense which Principal may have by reason of the order, decree or decision of any court or administrative body resulting from any such proceeding.
- (b) Guarantor acknowledges and agrees that any interest on any portion of the Obligations which accrues after the commencement of any proceeding referred to in clause (a) above (or, if interest on any portion of the Obligations ceases to accrue by operation of law by reason of the commencement of said proceeding, such interest as would have accrued on such portion of the Obligations if said proceedings had not been commenced) shall be included in the Obligations because it is the intention of Guarantor and Beneficiary that the Obligations which are guaranteed by Guarantor pursuant to this Guaranty should be determined without regard to any rule of law or order which may relieve Principal of any portion of such Obligations. Guarantor will permit any trustee in bankruptcy, receiver, debtor in possession, assignee for the benefit of creditors or similar person to pay Beneficiary, or allow the claim of Beneficiary in respect of, any such interest accruing after the date on which such proceeding is commenced.

6. Subrogation.

The Guarantor shall be subrogated to all rights of the Beneficiary against Principal in respect of any amounts paid by the Guarantor pursuant to the Guaranty, provided that the Guarantor postpones any rights that it may acquire by way of subrogation under this Guaranty, by any payment made hereunder or otherwise, reimbursement, exoneration, contribution, indemnification or any right to participate in any claim or remedy of the Beneficiary against Principal or any collateral that the Beneficiary now has or hereafter acquires, until all of the Obligations shall have been irrevocably paid to the Beneficiary in full.

If any amount shall be paid to Guarantor on account of such subrogation, reimbursement, contribution or indemnity rights at any time when all the Obligations guaranteed hereunder shall not have been indefeasibly paid in full, Guarantor shall hold such amount in trust for the benefit of Beneficiary (provided that no fiduciary duty shall be deemed to arise in connection therewith) and shall promptly pay such amount to Beneficiary.

Any rights of subrogation Guarantor may have against Principal or against such collateral or security shall be junior and subordinate to any rights Beneficiary may have against Principal and to all right, title and interest Beneficiary may have in such collateral or security. Beneficiary may use, sell or dispose of any item of collateral or security as it sees fit without regard to any subrogation rights that Guarantor may have, and upon any disposition or sale, any rights of subrogation Guarantor may have shall terminate. Guarantor understands that it may record a Request for Notice of Default pursuant to California Civil Code Section 2924b and thereby receive notice of any proposed foreclosure of any real property collateral then securing Principal's obligations under the Agreement. With respect to the foreclosure of any security interest in any personal property collateral then securing the Obligations, Beneficiary agrees to give Guarantor five (5) days' prior written notice, in the manner set forth in Paragraph 17 hereof, of any sale or disposition of any such personal property collateral, other than collateral which is perishable, threatens to decline speedily in value, is of a type customarily sold on a recognized market, or is cash, cash equivalents, certificates of deposit or the like. Guarantor's sole right with respect to any such foreclosure of real or personal property collateral shall be to bid at such sale in accordance with applicable law. Guarantor acknowledges and agrees that Beneficiary may also bid at any such sale and if such collateral is sold to Beneficiary in whole or partial satisfaction of Principal's obligations under the Agreement, including the Obligations (or any portion thereof), Guarantor shall not have any further right or interest with respect thereto. The rights of Beneficiary under this Paragraph 6 are in addition to other rights and remedies which Beneficiary may have.

7. Reserved.

8. Waivers of Guarantor.

To the fullest extent permitted by law;

- (a) Guarantor waives the benefit of any statute of limitations relating to the Obligations.
- (b) Guarantor waives any right to require Beneficiary to:
 - (i) proceed against Principal;
 - (ii) proceed against or exhaust any security held from Principal or any other party acting under a separate agreement; or
 - (iii) pursue any other remedy available to Beneficiary.
- (c) Guarantor waives all of the rights and defenses described in subdivision (a) of Section 2856 of the California Civil Code. As used below in this Subparagraph (c), "debtor" and "principal" each refers to Principal, "creditor" refers to Beneficiary, "guarantor" refers to "Guarantor" and "debt" refers to

The contents of this document are subject to restrictions on disclosure as set forth herein.

the Obligations. Without limiting the generality of the waiver in the first sentence of this Subparagraph (c), Guarantor desires and intends to, and hereby does, waive each and all of the rights and defenses described below in this Subparagraph (c).

- (i) The guarantor waives all rights and defenses that the guarantor may have because the debtor's debt is secured by real property. This means, among other things:
 - a. The creditor may collect from the guarantor without first foreclosing on any real or personal property collateral pledged by the debtor.
 - b. If the creditor forecloses on any real property collateral pledged by the debtor:
 - (1) The amount of the debt may be reduced only by the price for which that collateral is sold at the foreclosure sale, even if the collateral is worth more than the sale price.
 - (2) The creditor may collect from the guarantor even if the creditor, by foreclosing on the real property collateral, has destroyed any right the guarantor may have to collect from the debtor.

This is an unconditional and irrevocable waiver of any rights and defenses the guarantor may have because the debtor's debt is secured by real property. These rights and defenses include, but are not limited to, any rights or defenses based upon Section 580a, 580b, 580d, or 726 of the California Code of Civil Procedure.

- (ii) The guarantor waives all rights and defenses arising out of an election of remedies by the creditor, even though that election of remedies, such as a nonjudicial foreclosure with respect to security for a guaranteed obligation, has destroyed the guarantor's rights of subrogation and reimbursement against the principal by the operation of Section 580d of the Code of Civil Procedure or otherwise.
- (d) Guarantor assumes all responsibility for keeping itself informed of Principal's financial condition and all other factors affecting the risks and liability assumed by Guarantor hereunder, and Beneficiary shall have no duty to advise Guarantor of information known to it regarding such risks.
- (e) Guarantor waives any defense arising by reason of the incapacity, lack of authority or any disability or other defense of the Principal, including, without

The contents of this document are subject to restrictions on disclosure as set forth herein.

limitation, any defense based on or arising out of the lack of validity or enforceability of the Obligations or by reason of the cessation of liability of the Principal under the Agreement for any reason;

- (f) Guarantor waives any defense based upon any statute or rule of law that provides that the obligation of a surety must be neither larger in amount nor in other respects more burdensome than that of the principal;
- (g) Guarantor waives any defense based upon Beneficiary's errors or omissions in the administration of the Obligations;
- (h) Guarantor waives its right to raise any principles of law, statutory or otherwise, that are or might be in conflict with the terms of this Guaranty and any legal or equitable discharge of Guarantor's obligations hereunder;
- (i) Guarantor waives any rights to setoffs, recoupments or counterclaims against Beneficiary;
- (j) Guarantor waives its right to raise any defenses based upon promptness, diligence, and any requirement that Beneficiary protect, secure, perfect or insure any security interest or lien or any property subject thereto;
- (k) Guarantor waives any defenses or benefits that may be derived from or afforded by law which limit the liability of or exonerate guarantors or sureties, or which may conflict with the terms of this Guaranty;
- (l) Guarantor waives any rights or defenses that Guarantor may have under Sections 2899 and 3433 of the California Civil Code;
- (m) Guarantor waives any defense based upon Beneficiary's election, in any proceeding instituted under the United States Bankruptcy Code, as amended, of the application of Section 1111(b)(2) of the United States Bankruptcy Code, as amended, or any successor statute; and
- (n) Guarantor waives any defense based upon any borrowing or any grant of a security interest under Section 364 of the United States Bankruptcy Code, as amended.

9. No Waiver of Rights by Beneficiary.

No right or power of Beneficiary under this Guaranty shall be deemed to have been waived by any act or conduct on the part of Beneficiary, or by any neglect to exercise a right or power, or by any delay in doing so, and every right or power of Beneficiary hereunder shall continue in full force and effect until specifically waived or released in a written document executed by Beneficiary.

10. Assignment, Successors and Assigns.

This Guaranty shall be binding upon Guarantor, its successors and assigns, and shall inure to the benefit of, and be enforceable by, the Beneficiary, its successors and permitted assigns of the Obligations, and can be modified only by a written instrument signed by the Beneficiary and the Guarantor. The Beneficiary shall have the right to assign this Guaranty to any person or entity that is an assignee of the Beneficiary's right in respect of the Obligations without the prior consent of the Guarantor; *provided, however*, that no such assignment shall be binding upon the Guarantor, and any performance hereunder made to the Beneficiary shall be effective, until it receives written notice of such assignment from the Beneficiary. The Guarantor shall have no right to assign this Guaranty or its obligations hereunder without the prior written consent of the Beneficiary, which shall not be unreasonably withheld. Any reasonable uncertainty on the part of the Beneficiary concerning the ability on the part of any potential assignee of the Guarantor to carry out the Guarantor's obligations hereunder shall be considered a reasonable basis for withholding consent.

11. Representations of Guarantor.

Guarantor hereby represents and warrants that:

- (a) It is an entity duly organized, validly existing and in good standing in all necessary jurisdictions and has full power and authority to execute, deliver and perform this Guaranty;
- (b) It has taken all necessary actions to execute, deliver and become obligated under this Guaranty;
- (c) This Guaranty constitutes the legal, valid and binding obligation of Guarantor, enforceable in accordance with its terms, subject to bankruptcy, insolvency, reorganization, moratorium and other similar laws affecting creditors' rights generally and to general equitable principles;
- (d) Execution, delivery and performance by Guarantor of this Guaranty does not conflict with, violate or create a default under any of its governing documents, any agreement or instruments to which it is a party or to which any of its assets is subject or any applicable law, rule, regulation, order or judgment of any Governmental Authority; and
- (e) All consents, approvals and authorizations of governmental authorities required in connection with Guarantor's execution, delivery and performance of this Guaranty have been duly and validly obtained and remain in full force and effect.

12. Attorneys' Fees.

The contents of this document are subject to restrictions on disclosure as set forth herein.

In addition to the amounts for which payment is guaranteed hereunder, Guarantor agrees to pay reasonable attorneys' fees and all other costs and expenses incurred by Beneficiary in enforcing this Guaranty or in any action or proceeding arising out of or relating to this Guaranty. Any costs for which Guarantor becomes liable pursuant to this Paragraph 12 shall not be subject to, and shall not count toward, the guaranty limit set forth in Paragraph 2 above.

13. Governing Law.

This agreement is made under and shall be governed in all respects by the laws of the State of California, without regard to conflict of law principles, and its provisions may not be waived, altered, modified or amended except in writing executed by an officer of each of Guarantor and Beneficiary. If any provision of this Guaranty is held invalid under the laws of California, this agreement shall be construed as though the invalid provision has been deleted, and the rights and obligations of the parties shall be construed accordingly.

14. Construction.

All parties to this agreement are represented by legal counsel. The terms of this agreement and the language used in this agreement shall be deemed to be the terms and language chosen by the parties hereto to express their mutual intent. This agreement shall be construed without regard to any presumption or rule requiring construction against the party causing such instrument or any portion thereof to be drafted, or in favor of the party receiving a particular benefit under this agreement. No rule of strict construction will be applied against any person.

15. Amendment; Severability.

Neither this Guaranty nor any of the terms hereof may be terminated, amended, supplemented or modified, except by an instrument in writing executed by an authorized representative of each of Guarantor and Beneficiary. If any provision in or obligation under this Guaranty shall be invalid, illegal or unenforceable in any jurisdiction, the validity, legality and enforceability of the remaining provisions or obligations, or of such provision or obligation in any other jurisdiction, shall not in any way be affected or impaired thereby.

16. Third Party Rights.

This Guaranty shall not be construed to create any rights in any person other than Guarantor and Beneficiary and their respective successors and permitted assigns.

17. Notices.

Any notice given hereunder by either Guarantor or Beneficiary shall be made by facsimile to the person and at the address for notices specified below (with notices to Guarantor sent to facsimile and address specific below for Beneficiary).

Beneficiary.

Southern California Edison Company
2244 Walnut Grove Avenue
Rosemead, CA 91770

Attn: [REDACTED]

Phone: [REDACTED]

Facsimile: [REDACTED]

with a copy to:

Southern California Edison Company
2244 Walnut Grove Avenue
Rosemead, CA 91770

Attn: [REDACTED]

Phone: [REDACTED]

Facsimile: [REDACTED]

Guarantor.

[Guarantor]

[Street]

[City, State Zip]

Attn:

Phone:

Facsimile:

Principal.

[Principal]
[Street]
[City, State Zip]
Attn:
Phone:
Facsimile:

Such notice shall be effective upon actual receipt if received during the recipient's normal business hours, or at the beginning of the recipient's next Business Day after receipt if receipt is outside of the recipient's normal business hours. Either party may periodically change any address to which notice is to be given it by providing notice of such change as provided herein.

Guarantor.

_____ *[legal name]*
By: _____
Title: _____
Date: _____

Beneficiary.

Agreed to by Beneficiary for purposes of establishing the creditworthiness of Principal, as partial security for the Agreement.

SOUTHERN CALIFORNIA EDISON COMPANY
By: _____
Title: _____
Date: _____

*** *End of EXHIBIT I* ***

The contents of this document are subject to restrictions on disclosure as set forth herein.

EXHIBIT J

Notice of Right of First Offer

The contents of this document are subject to restrictions on disclosure as set forth herein.

EXHIBIT J

Notice of Right of First Offer

RECORDING REQUESTED BY

AND WHEN RECORDED MAIL TO:

Southern California Edison
2244 Walnut Grove Avenue
Rosemead, California 91770
[Redacted]

APN: _____

(Space Above for Recorder's Use Only)

NOTICE OF RIGHT OF FIRST OFFER

NOTICE IS HEREBY GIVEN THAT SOUTHERN CALIFORNIA EDISON COMPANY, a California corporation ("SCE"), and _____, a _____ ("Seller"), have entered into that certain Generating Facility Power Purchase and Sale Agreement dated as of _____ (as amended, supplemented and revised from time to time, the "Agreement"). Pursuant to the Agreement, SCE has a Right of First Offer (as defined in the Agreement) to purchase all electric energy, Green Attributes, Capacity Attributes and/or Resource Adequacy Benefits (as such terms are defined in the Agreement) associated with or attributable to any generating facilities located or to be located on that certain real property (the "Property") more particularly described on Exhibit A attached hereto and incorporated herein by the reference.

The Right of First Offer shall terminate as set forth in the Agreement, but not later than _____. This Notice shall terminate automatically on _____, unless earlier terminated by SCE by recording a notice of termination.

Reference is made to the Agreement for the terms and conditions of the Right of First Offer. In the event of a conflict between the terms of this Notice and the terms of the Agreement, the terms of the Agreement shall control.

[Signatures are on the following page]

The contents of this document are subject to restrictions on disclosure as set forth herein.

_____ ,

**SOUTHERN CALIFORNIA EDISON
COMPANY,**

a _____ .

a California corporation.

By: _____

By: _____

Its:

Its:

Date: _____

Date: _____

By: _____

Its:

Date: _____

EXHIBIT A

The contents of this document are subject to restrictions on disclosure as set forth herein.

ACKNOWLEDGMENTS

STATE OF _____)
) SS.
COUNTY OF _____)

On _____, personally appeared before me, a Notary Public,
_____, as _____ of **SOUTHERN CALIFORNIA EDISON COMPANY**, personally known or proved to me to be the person whose name is subscribed to the above instrument who acknowledged to me that he executed the above instrument on behalf of **SOUTHERN CALIFORNIA EDISON COMPANY**.

WITNESS my hand and official Seal.

Notary Public in and for said State

My commission expires: _____

STATE OF _____)
) SS.
COUNTY OF _____)

On _____, personally appeared before me, a Notary Public,
_____, as _____ of _____, personally known or proved to me to be the person whose name is subscribed to the above instrument who acknowledged to me that he executed the above instrument on behalf of _____.

WITNESS my hand and official Seal.

Notary Public in and for said State

My commission expires: _____

The contents of this document are subject to restrictions on disclosure as set forth herein.

**** End of EXHIBIT J ****

The contents of this document are subject to restrictions on disclosure as set forth herein.

EXHIBIT K

Time of Delivery Periods

and

Energy Payment Allocation Factors

The contents of this document are subject to restrictions on disclosure as set forth herein.

EXHIBIT K

*Time Of Delivery Periods
and
Energy Payment Allocation Factors*

<i>Time of Delivery Periods ("TOD Periods")</i>			
<i>TOD Period</i>	<i>Summer Jun 1st – Sep 30th</i>	<i>Winter Oct 1st – May 31st</i>	<i>Applicable Days</i>
On-Peak	Noon – 6:00 p.m.	Not Applicable.	Weekdays except Holidays.
Mid-Peak	8:00 a.m. – Noon	8:00 a.m. – 9:00 p.m.	Weekdays except Holidays.
	6:00 p.m. – 11:00 p.m.		Weekdays except Holidays.
Off-Peak	11:00 p.m. – 8:00 a.m.	6:00 a.m. – 8:00 a.m.	Weekdays except Holidays.
		9:00 p.m. – Midnight	Weekdays except Holidays.
	Midnight – Midnight	6:00 a.m. – Midnight	Weekends and Holidays
Super-Off-Peak	Not Applicable.	Midnight – 6:00 a.m.	Weekdays, Weekends and Holidays

The contents of this document are subject to restrictions on disclosure as set forth herein.

<u>Energy Payment Allocation Factors</u>			
<i>Season</i>	<i>TOD Period</i>	<i>Calculation Method</i>	<i>Energy Payment Allocation Factor</i>
Summer	On-Peak	Fixed Value.	1.4251
	Mid-Peak	(Total # hours in month – (1.4251 x # Summer On-Peak hours in month) - (0.8526 x # Summer Off-Peak hours in month)) / #Summer Mid-Peak hours in month	Calculated Value
	Off-Peak	Fixed Value.	0.8526
Winter	Mid-Peak	Fixed Value.	1.2185
	Off-Peak	(Total # hours in month – (1.2185 x # Winter Mid-Peak hours in month) - (0.7760 x # Winter Super-Off-Peak hours in month)) / #Winter Off-Peak hours in month	Calculated Value
	Super-Off-Peak	Fixed Value.	0.7760

“Holiday” is defined as New Year’s Day, Presidents’ Day, Memorial Day, Independence Day, Labor Day, Veterans Day, Thanksgiving Day, or Christmas Day.

When any Holiday falls on a Sunday, the following Monday will be recognized as a Holiday. No change will be made for Holidays falling on Saturday.

*** End of EXHIBIT K ***

The contents of this document are subject to restrictions on disclosure as set forth herein.

EXHIBIT L

Benchmark Bid Prices

The contents of this document are subject to restrictions on disclosure as set forth herein.

EXHIBIT L*Benchmark Bid Prices***TABLE A****BENCHMARK BID PRICES**

<i>Calendar Year of Installed Capacity (MW)</i>	<i>Benchmark Bid Price (\$ per MWh)</i>
2007	69.88
2008	71.48
2009	72.38
2010	73.30
2011	74.23
2012	75.18
2013	76.13
2014	77.10
2015	78.08
2016	79.08
2017	80.10
2018	81.12
2019	82.16
2020	83.22

*Benchmark Bid prices includes costs of Performance Assurance Amount of \$87,500/MW Nameplate Contract Capacity.

*** End of EXHIBIT L ***

The contents of this document are subject to restrictions on disclosure as set forth herein.

EXHIBIT M

Seller's Estimate of Lost Output

The contents of this document are subject to restrictions on disclosure as set forth herein.

EXHIBIT M

Seller's Estimate Of Lost Output

1. Introduction.

Lost Output, as used in Section 3.18, shall be estimated by Seller in accordance with the procedures described in this Exhibit M.

The intent is that:

- (a) Seller's estimate of Lost Output be as simple and transparent as possible;
- (b) Seller shall provide a:
 - (i) Preliminary estimate of Lost Output at the end of each month which is based upon the:
 - (1) Wind Turbine Manufacturer's Power Curve after adjustment for applicable Site conditions and losses for the first Facility Term Year; and
 - (2) Final Generating Facility Power Curve for the previous Facility Term Year for all Facility Term Years, except the first Facility Term Year;
 - (ii) Final estimate of Lost Output at the end of each Facility Term Year that is based upon a Generating Facility Power Curve which is:
 - (1) Derived from the Wind Speed and Metered Amounts data that is recorded for the Lost Output Facility Term Year being calculated; and
 - (2) Based upon the simple average of the Metered Amounts data at each Wind Speed Interval.
- (c) There be a single Generating Facility Power Curve and a single free wind stream meteorological station for the entire Generating Facility;
- (d) Seller may elect to utilize multiple Generating Facility Power Curves by:
 - (i) Establishing wind turbine groups;
 - (ii) Installing a dedicated meteorological station for each group; and
 - (iii) Performing the calculations set forth below for each group.

The contents of this document are subject to restrictions on disclosure as set forth herein.

- (e) The descriptions that follow provide an outline of the general form and organization of the required calculations, but do not strictly limit the Excel Workbook calculations to only the designated columns and rows.

2. Seller's Obligations.

Seller shall:

- (a) Collect the measurement data and perform the engineering calculations specified below in one (1) or more Microsoft Excel Workbooks (the "Lost Output Workbook") in a form and naming convention approved by SCE; and
- (b) Electronically send the Lost Output Workbook to an address provided by SCE.

Seller shall update the Lost Output Workbook each month and shall include the latest revision of the Lost Output Workbook with its monthly Lost Output Report.

3. Log of Lost Output Events.

The Log of Lost Output Events shall be created on a single, dedicated worksheet that is arranged with:

- (a) One (1) column for a Lost Output event number;
- (b) One (1) column for the Facility Term Year number;
- (c) One (1) column for the cause;
- (d) One (1) column for the start date and time ;
- (e) One (1) column for the end date and time;
- (f) One (1) column for the duration;
- (g) One (1) column for actual Metered Amounts;
- (h) Three (3) columns for the Preliminary Results, including:
- (i) One (1) column for the total estimated Metered Amounts quantity that is equal to the sum of estimated Metered Amounts during all of the Settlement Intervals of the Lost Output event;
- (ii) One (1) column for the total of the Lost Output *preliminary* results during all of the Settlement Intervals of the Lost Output event, as set forth in Item #6(a)(ii) in this Exhibit M;

The contents of this document are subject to restrictions on disclosure as set forth herein.

- (iii) One (1) column for a percentage calculated by:
 - (1) *Dividing* the preliminary results set forth in Item #3(h)(ii) of this Exhibit M;
 - (2) *By* the Metered Amounts set forth in Item #3(h)(i) of this Exhibit M;
- (i) Three (3) columns for the Final Results, including:
 - (i) One (1) column for the total estimated Metered Amounts quantity that is equal to the sum of estimated Metered Amounts during all of the Settlement Intervals of the Lost Output event;
 - (ii) One (1) column for the total of the Lost Output *final* results during all of the Settlement Intervals of the Lost Output event, as forth in Item #6(b)(ii) in this Exhibit M; and
 - (iii) One (1) column for a percentage calculated by:
 - (1) *Dividing* the preliminary results set forth in Item #3(i)(ii) of this Exhibit M;
 - (2) *By* the Metered Amounts set forth in Item #3(i)(i) of this Exhibit M.

4. Generating Facility Power Curve.

Seller shall create a Generating Facility Power Curve table on a single dedicated worksheet that is arranged with:

- (a) One (1) column for an item number;
- (b) One (1) column for the wind speeds;
- (c) One (1) column for the manufacturer's estimate of the electric energy that can be produced by a single Wind Turbine at each wind speed;
- (d) One (1) column for a Generating Facility Power Curve which estimates the electric energy that could be produced by the entire Generating Facility at each wind speed calculated by:
 - (i) *Multiplying* the estimate of the electric energy that will be produced by a single Wind Turbine using the Wind Turbine Manufacturer's Power Curve set forth in Item #4(c);
 - (ii) *Times* the total number of Generating Facility Wind Turbines; and then

The contents of this document are subject to restrictions on disclosure as set forth herein.

- (iii) *Adjusting* the results for the estimated impacts of wake losses, applicable site conditions and for electric losses within the Generating Facility;
- (e) One (1) column for each Facility Term Year Generating Facility Power Curve which is based upon the simple average of all Metered Amounts data points for each wind speed during all time periods when there is no Lost Output; and
- (f) One (1) row for each one half (0.5) meter per second Wind Speed interval (each a "Wind Speed Interval").

Seller shall also create a single chart which plots all of the Generating Facility Power Curves set forth in Item #4(d) and Item #4(e) of this Exhibit M on the Generating Facility Power Curve worksheet.

5. Wind Speed Data Collection.

Seller shall record average Settlement Interval wind speeds, in increments of one half (0.5) meters per second, and Settlement Interval Metered Amounts in the Lost Output Workbook on individual Facility Term Year worksheets.

Each Facility Term Year worksheet shall be arranged with:

- (a) One (1) column for an item number;
- (b) One (1) column for the date;
- (c) One (1) column for the beginning time;
- (d) One (1) column for the weekday;
- (e) One (1) column for each recorded wind speed measurement;
- (f) One (1) column for each Metered Amounts quantity; and
- (g) One (1) row for each Settlement Interval period.

6. Detailed Estimate of Lost Output.

Seller's detailed estimate of the Lost Output amounts shall be included as a separate section of the Wind Speed Data Collection worksheet described in Item #5 and organized as follows:

- (a) Two (2) columns for the *preliminary* results, including:
 - (i) One (1) columns for the preliminary estimate of Metered Amounts for all Settlement Intervals determined by using the appropriate initial Generating Facility Power Curve as follows:

The contents of this document are subject to restrictions on disclosure as set forth herein.

- (1) For the first eleven (11) months of the first Facility Term Year the appropriate initial Generating Facility Power Curve shall be the power curve set forth in Item #4(d) of this Exhibit M;
- (2) For the first eleven (11) months of any Facility Term Year, other than the first Facility Term Year, the appropriate initial Generating Facility Power Curve shall be the Generating Facility Power Curve set forth in Item #4(e) of this Exhibit M for the previous Facility Term Year; and
- (ii) One (1) column for a *final* result estimate of Lost Output during the Lost Output event calculated by:
 - (1) *Subtracting* the actual Metered Amounts quantity set forth in Item #5(f);
 - (2) *From* the results calculated in Item #6(a)(i) of this Exhibit M;
- (b) Two (2) columns for the final results, including:
 - (i) One (1) column for the final estimate of Metered Amounts for all Settlement Intervals determined by using the *final* Generating Facility Power Curve from Item 4(e) for the Facility Term Year being calculated;
 - (ii) One (1) column for the result of:
 - (1) *Subtracting* the actual Metered Amounts quantities set forth in Item 5(f) of this Exhibit M;
 - (2) *From* the results calculated in Item 6(a)(i) of this Exhibit M; and
- (c) One (1) row for each Settlement Interval.

7. Assignment of Lost Output Estimate to an Independent Consultant.

The Parties can by mutual agreement elect to have the estimate of Lost Output prepared by an independent consultant.

*** End of EXHIBIT M ***

The contents of this document are subject to restrictions on disclosure as set forth herein.

EXHIBIT N

Form of Letter of Credit

The contents of this document are subject to restrictions on disclosure as set forth herein.

EXHIBIT N

Form Of Letter Of Credit

IRREVOCABLE NONTRANSFERABLE STANDBY

LETTER OF CREDIT

Reference Number: _____

Transaction Date:

BENEFICIARY:

Southern California Edison Company
2244 Walnut Grove Avenue
Risk Control GO#1, Quad 2A
Rosemead, CA 91770

Ladies and Gentlemen:

_____ (the "Bank") hereby establishes this Irrevocable Nontransferable Standby Letter of Credit ("Letter of Credit") in favor of Southern California Edison Company, a California corporation (the "Beneficiary"), for the account of _____, a _____ limited liability company, (the "Applicant"), for the amount of _____ AND 00/100 Dollars (\$ _____) (the "Available Amount"), effective immediately and expiring at 5:00 p.m., New York time, on the Expiration Date (as hereinafter defined).

This Letter of Credit shall be of no further force or effect upon the close of business on _____ or, if such day is not a Business Day (as hereinafter defined), on the next preceding Business Day.

For the purposes hereof, "Business Day" shall mean any day on which commercial banks are not authorized or required to close in New York City, New York and "Expiration Date" shall mean _____.

Subject to the terms and conditions herein, funds under this Letter of Credit are available to Beneficiary by presentation in compliance on or prior to 5:00 p.m. New York time, on or prior to the Expiration Date of the following:

1. The original of this Letter of Credit and all amendments (or photocopy of the original for partial drawings); and
2. The Drawing Certificate issued in the form of Attachment A attached hereto and which forms an integral part hereof, duly completed and purportedly bearing the signature of an authorized representative of the Beneficiary.

The contents of this document are subject to restrictions on disclosure as set forth herein.

Payment shall be made by the bank in the amount specified in the Beneficiary's declaration (up to the maximum amount then available under the Letter of Credit (a) if a drawing is made by the Beneficiary hereunder at or prior to 1:00 p.m. (New York City time) on such Business Day, not later than 5:00 p.m. (New York City time) on such Business Day, or (b) if a drawing is made by the Beneficiary hereunder after 1:00 p.m. (New York City time) on a Business Day, not later than 10:00 a.m. (New York City time) on the next succeeding Business Day, provided, in each case, such drawing and the documents presented therewith conform to the terms and conditions thereof.

There is no responsibility on the part of the Bank to investigate the authenticity of the declaration or the capacity or entitlement of the declarants to made the declaration.

Partial drawing of funds shall be permitted under this Letter of Credit, and this Letter of Credit shall remain in full force and effect with respect to any continuing balance; *provided that*, the Available Amount shall be reduced by the amount of each such drawing.

This Letter of Credit is not transferable or assignable. Any purported transfer or assignment shall be void and of no force or effect.

[This Letter of Credit is issued under the Subscription Agreement dated 22 September, 20___, between Terra-Gen Power, LLC, the Bank and others.] [If required by the Letter of Credit Bank.]

Banking charges shall be the sole responsibility of the Applicant.

This Letter of Credit sets forth in full our obligations and such obligations shall not in any way be modified, amended, amplified or limited by reference to any documents, instruments or agreements referred to herein, except only the attachment referred to herein; and any such reference shall not be deemed to incorporate by reference any document, instrument or agreement except for such attachment.

The Bank engages with the Beneficiary that the Beneficiary's drafts drawn under and in compliance with the terms of this Letter of Credit will be duly honored if presented to the Bank on or before the Expiration Date.

Except so far as otherwise stated, this Letter of Credit is subject to the International Standby Practices ISP98 (also known as ICC Publication No. 590), or revision currently in effect (the "ISP"). As to matters not covered by the ISP, the laws of the State of New York, without regard to the principles of conflicts of laws thereunder, shall govern all matters with respect to this Letter of Credit.

AUTHORIZED SIGNATURE for Issuer

(Name)

Title: _____

The contents of this document are subject to restrictions on disclosure as set forth herein.

ATTACHMENT A
DRAWING CERTIFICATE
TO [ISSUING BANK NAME]
IRREVOCABLE NON-TRANSFERABLE STANDBY LETTER OF CREDIT
No. _____

DRAWING CERTIFICATE
Bank
Bank Address

Subject: Irrevocable Non-transferable Standby Letter of Credit
Reference Number: _____

The undersigned _____, an authorized representative of Southern California Edison Company (the "Beneficiary"), hereby certifies to [Issuing Bank Name] (the "Bank"), and _____ (the "Applicant"), with reference to Irrevocable Nontransferable Standby Letter of Credit No. {_____}, dated _____, (the "Letter of Credit"), issued by the Bank in favor of the Beneficiary, as follows as of the date hereof:

1. The Beneficiary is entitled to draw under the Letter of Credit an amount equal to \$ _____, for the following reason(s) [check applicable provision]:
 - []A. An Event of Default, as defined in that certain Generating Facility Power Purchase and Sale Agreement between Applicant and Beneficiary, dated as of [Date of Execution] (the "Agreement"), with respect to the Applicant has occurred and is continuing.
 - []B. An Early Termination Date (as defined in the Agreement) has occurred or been designated as a result of an Event of Default (as defined in the Agreement) with respect to the Applicant for which there exist any unsatisfied payment obligations.
 - []C. The Letter of Credit will expire in fewer than 20 Local Business Days (as defined in the Agreement) from the date hereof, and Applicant has not provided Beneficiary alternative Performance Assurance (as defined in the Agreement) acceptable to Beneficiary.
 - []D. The Bank has heretofore provided written notice to the Beneficiary of the Bank's intent not to renew the Letter of Credit following the present Expiration Date thereof ("Notice of Non-renewal"), and Applicant has failed to provide the Beneficiary with a replacement letter of credit satisfactory to

The contents of this document are subject to restrictions on disclosure as set forth herein.

Beneficiary in its sole discretion within thirty (30) days following the date of the Notice of Non-renewal.

- 2. Based upon the foregoing, the Beneficiary hereby makes demand under the Letter of Credit for payment of U.S. DOLLARS AND ____/100ths (U.S.\$ _____), which amount does not exceed (i) the amount set forth in paragraph 1 above, and (ii) the Available Amount under the Letter of Credit as of the date hereof.
- 3. Funds paid pursuant to the provisions of the Letter of Credit shall be wire transferred to the Beneficiary in accordance with the following instructions:

Unless otherwise provided herein, capitalized terms which are used and not defined herein shall have the meaning given each such term in the Letter of Credit.

IN WITNESS WHEREOF, this Certificate has been duly executed and delivered on behalf of the Beneficiary by its authorized representative as of this ____ day of _____, _____.

Beneficiary: SOUTHERN CALIFORNIA EDISON COMPANY

By:
Name:
Title:

*** *End of EXHIBIT N* ***

EXHIBIT O

Seller's Long Term Availability Shortfall Payment

The contents of this document are subject to restrictions on disclosure as set forth herein.

EXHIBIT O*Seller's Long Term Availability Shortfall Payment*1) Introduction.

Seller's Long Term Availability Shortfall Payment for each of:

- a) Seller's *First* Long Term Availability Guarantee Period; and
- b) Seller's *Second* Long Term Availability Guarantee Period,

shall be determined in accordance with the requirements set forth in Section 3.05 and the following formulas.

2) SELLER'S LONG TERM AVAILABILITY SHORTFALL PAYMENT in dollars, equals the greater of zero (0) and the result of:

$$(A_{01} \times B_{01}) - C_{01}$$

Where:

A_{01} = Seller's Long Term Availability Shortfall calculated as set forth in Item #3 of this Exhibit O, in MWh.

B_{01} = *The lesser of:*

- a) Ten dollars (\$10.00) per MWh; and
- b) *The greater of:*
 - (i) Zero dollars (\$0.00) per MWh; and
 - (ii) *The result of:*

$$A_{02} - B_{02}$$

Where:

A_{02} = The simple average of the Market Price for all Settlement Intervals in the applicable five (5) year period, in dollars per MWh.

B_{02} = The Energy Price, in dollars per MWh.

C_{01} = The sum of all Seller's Annual Energy Delivery Obligation Shortfall Payments, in

The contents of this document are subject to restrictions on disclosure as set forth herein.

the applicable five (5) year period,
in dollars.

3) SELLER'S LONG TERM AVAILABILITY SHORTFALL, in MWh

$$= A_{O3} \times B_{O3} \times C_{O3}$$

Where:

A_{O3} = *The lesser of:*

- (a) Five percent (5%); and
- (b) *The greater of:*
 - (i) Zero percent (0%); and
 - (ii) *The result of:*

$$A_{O4} - B_{O4}$$

Where:

A_{O4} = Ninety percent (90%);

B_{O4} = The Actual Generating Facility Long Term Availability for the guarantee period, in percent; *provided that*, if with respect to any Facility Term Year in such guarantee period, the Actual Generating Facility Annual Availability for such Facility Term Year was less than eighty-five percent (85%), then the actual availability for each calculation interval in such Facility Term Year shall be assumed, for the purposes of this calculation, to be eighty-five percent (85%).

B_{O3} = The Estimated Annual Production, in MWh.

C_{O3} = Five (5).

*** End of EXHIBIT O ***

The contents of this document are subject to restrictions on disclosure as set forth herein.

EXHIBIT P

ISO Change Cost Payment Calculation

The contents of this document are subject to restrictions on disclosure as set forth herein.

EXHIBIT P

ISO Change Cost Payment Calculation

1. Introduction.

ISO Change Cost for any Facility Term Year shall be calculated in accordance with the following formula:

$$\text{ISO CHANGE COST} = \sum_{\text{TermYearHour}\#1}^{\text{TermYearHourLast}} [A_{\text{before}} - B_{\text{before}} - C_{\text{before}} - D_{\text{before}}] - \sum_{\text{TermYearHour}\#1}^{\text{TermYearHourLast}} [A_{\text{after}} - B_{\text{after}} - C_{\text{after}} - D_{\text{after}}]$$

Where:

- (a) As used herein, “Seller’s Actual Revenue” means the total of payments and Production Tax Credits which arise solely out of production of energy from the Generating Facility received by Seller in any Facility Term Year consisting of payments received by Seller during the Facility Term Year pursuant to Article Four, excluding any payment adjustments pursuant to Section 4.02(b); and
- (b) As used herein, “Seller’s Adjusted Revenue” means the calculated amount of Seller’s revenue in any Facility Term Year based on adjustments to Seller’s Actual Revenue, in order to measure the hypothetical amount of revenue that would have been realized by Seller during the Facility Term Year (i) assuming that the Generating Facility was a Participating Intermittent Resource and using the ISO’s methodology and procedures that would have applied as of the Master Agreement Effective Date, or (ii) if PIRP or a successor program to PIRP is in effect and generating facilities with the size and characteristics of the Generating Facility are eligible to participate in PIRP or the successor program to PIRP, but Seller is not in PIRP or the successor program to PIRP, using the ISO’s methodology and procedures that would have applied assuming the Generating Facility was not a Participating Intermittent Resource either as of the Master Agreement Effective Date or before any Change in ISO Tariff, as compared to the ISO’s methodology and procedures that apply during the Facility Term Year, as specified for each factor below.

2. Formula Factors.

The formula factors A_{before} , A_{after} , B_{before} , B_{after} , C_{before} , C_{after} , D_{before} and D_{after} are described as follows:

The contents of this document are subject to restrictions on disclosure as set forth herein.

- (a) Changes in ISO Allocation of Transmission Congestion and ISO Transmission Loss Methodologies Impacting Scheduled Amounts or Delivered Amounts.

A_{before} = Seller's Adjusted Revenue based on calculating the adjustments to Seller's Actual Revenue, either up or down, under the following circumstances:

- (i) Changes In Methodology For Allocating Transmission Congestion Which Impact Scheduled Amounts or Delivered Amounts.

Upon the occurrence of congestion on the transmission system, changes to Seller's actual Scheduled Amounts (if SCE is not acting as Seller's Scheduling Coordinator) or Delivered Amounts (if SCE is acting as Seller's Scheduling Coordinator) during the Facility Term Year that would result from applying the ISO's methodology and procedures in effect *immediately prior* to the first Change in ISO Tariff; and

- (ii) Changes In Loss Methodology Which Impact Scheduled Amounts or Delivered Amounts.

Changes in Seller's actual Scheduled Amounts (if SCE is not acting as Seller's Scheduling Coordinator) or Delivered Amounts (if SCE is acting as Seller's Scheduling Coordinator) during the Facility Term Year that would result from (1) applying the ISO's methodology and procedures for losses under PIRP, in effect as of the Master Agreement Effective Date, or (2) Seller self-providing all ISO-assessed transmission losses in Seller's Scheduled Amounts (if SCE is not acting as Seller's Scheduling Coordinator) or Delivered Amounts (if SCE is acting as Seller's Scheduling Coordinator) by applying the GMM using the ISO GMM procedures that would be applicable to the Generating Facility in effect as of the Master Agreement Effective Date and the average values of GMM for the twelve (12) calendar months *immediately prior* to the first Change in ISO Tariff, if PIRP or a successor program to PIRP is in effect and generating facilities with the size and characteristics of the Generating Facility are eligible to participate in PIRP or the successor program to PIRP, but Seller is not in PIRP or the successor program to PIRP.

The contents of this document are subject to restrictions on disclosure as set forth herein.

A_{after} = Seller's Actual Revenue during the Facility Term Year.

(b) Changes in ISO Tariff Impacting ISO Charges for Transmission Congestion.

B_{before} = This value shall be zero (0).

B_{after} = Actual amount of ISO charges paid by Seller during the Facility Term Year relating to congestion for delivery of Product from the Generating Facility to the Delivery Point.

(c) Changes in ISO Tariff Impacting ISO Charges for Transmission Losses.

C_{before} = This value shall be zero (0).

C_{after} = Actual amount of ISO charges paid by Seller during the Facility Term Year relating to transmission losses for delivery of Product from the Generating Facility to the Delivery Point.

(d) Changes in ISO Tariff Impacting PIRP.

D_{before} = Calculated amount of ISO charges that would have been paid by Seller during the Facility Term Year under the Participating Intermittent Resource Program using the ISO's methodology and procedures as of the Master Agreement Effective Date attributable solely to the Generating Facility.

D_{after} = Actual ISO charges paid by Seller attributable solely to the Generating Facility during the Facility Term Year resulting from changes in, or termination of, the Participating Intermittent Resource Program.

If PIRP or a successor program to PIRP is in effect and generating facilities with the size and characteristics of the Generating Facility are eligible to participate in PIRP or the successor program to PIRP, but Seller is not in PIRP or the successor program to PIRP, then D_{before} and D_{after} shall not be included in the ISO Change Cost calculation.

3. Change Cost Payments.

(a) Change Cost Payment to Seller.

If the ISO Change Cost is a *positive* number that is less than the ISO Change Cost Threshold Amount, then SCE shall pay to Seller an ISO Change Cost Payment calculated as follows:

$$\text{ISO CHANGE COST PAYMENT TO SELLER} = E \times 0.50$$

The contents of this document are subject to restrictions on disclosure as set forth herein.

Where:

E = ISO Change Cost as calculated above.

If the ISO Change Cost is a *positive* number that is greater than the ISO Change Cost Threshold Amount, then SCE shall pay to Seller an ISO Change Cost Payment calculated as follows:

$$\text{ISO CHANGE COST PAYMENT TO SELLER} = (E - F) + (F \times 0.50)$$

Where:

E = ISO Change Cost as calculated above.

F = ISO Change Cost Threshold Amount as set forth in Section 1.09.

(b) Change Cost Payment to SCE.

If the ISO Change Cost is a *negative* number the absolute of which is less than the ISO Change Cost Threshold Amount, then Seller shall pay to SCE an ISO Change Cost Payment calculated as follows:

$$\text{ISO CHANGE COST PAYMENT TO SCE} = (-1 \times E) \times (0.5)$$

Where:

E = ISO Change Cost as calculated above.

If the ISO Change Cost is a *negative* number the absolute of which is greater than the ISO Change Cost Threshold Amount, then Seller shall pay to SCE an ISO Change Cost Payment calculated as follows:

$$\text{ISO CHANGE COST PAYMENT TO SCE} = ((-1 \times E) - F) + (F \times 0.50)$$

Where:

E = ISO Change Cost as calculated above.

F = ISO Change Cost Threshold Amount as set forth in Section 1.09.

*** End of EXHIBIT P***

The contents of this document are subject to restrictions on disclosure as set forth herein.

EXHIBIT Q

*Forecasting and Scheduling Requirements and Procedure Applicable When
SCE is Seller's Scheduling Coordinator*

The contents of this document are subject to restrictions on disclosure as set forth herein.

EXHIBIT Q*Forecasting and Scheduling Requirements and Procedures Applicable When SCE is Seller's Scheduling Coordinator*1. Introduction.

The Parties shall abide by the Forecasting and Scheduling requirements and procedures described below when SCE is Seller's Scheduling Coordinator and Section 3.19(b) of this Power Purchase Agreement is applicable, and shall agree upon reasonable changes to these requirements and procedures from time-to-time, as necessary to:

- (a) Comply with ISO Tariff changes;
- (b) Accommodate changes to their respective generation technology and organizational structure; and
- (c) Address changes in the operating and Scheduling procedures of both SCE and the ISO, including but not limited to, automated forecast and outage submissions.

2. Seller's Availability Forecasting Requirements.

Seller must provide availability forecasts to SCE that meet all of the availability forecasting and reporting requirements of the ISO Tariff applicable to the Generating Facility and all of the availability forecasting and reporting requirements of the ISO Eligible Intermittent Resources Protocol ("EIRP") as of the Master Agreement Effective Date ("Availability Forecast").

3. SCE's Scheduling Responsibilities.

Pursuant to the ISO Tariff, SCE shall be responsible for the following:

- (a) Using the Availability Forecasts submitted to SCE pursuant to Section 2 above, including updated Availability Forecasts to the extent reasonably practicable, to forecast Seller's expected generation using SCE's forecasting model ("SCE's Projected Energy Forecast") in any given hour.
- (b) Adjusting SCE's Projected Energy Forecast for forecasted electric energy line losses to reflect Seller's self-provision of those losses and the amount of electric energy Seller is expected to deliver to the Delivery Point.
- (c) Submitting the adjusted forecasts to the ISO as SC Schedules.

The contents of this document are subject to restrictions on disclosure as set forth herein.

(d) Receiving notification of the Final Hour-Ahead Schedules from the ISO.

4. Seller's Outage Scheduling Requirements.

Seller shall be responsible for all expenses and costs associated with all requirements and timelines for generation outage scheduling contained in the ISO's Scheduled and Forced Outage Procedure T-113 as posted on the ISO's website.

**** End of EXHIBIT Q ****

EXHIBIT R
SCE Penalties and ISO Sanctions

The contents of this document are subject to restrictions on disclosure as set forth herein.

EXHIBIT R*SCE Penalties and ISO Sanctions*

This Exhibit R sets forth the procedure for determining Seller's liability for an SCE Penalty or an ISO Sanction (as described below) in the event Seller fails to comply with the availability forecasting requirements of Exhibit Q.

1. Determining Potential Applicability of SCE Penalty.

- (a) For any hour, SCE will review the Actual Availability Report to determine if Seller complied with its obligation as set forth in Exhibit Q to provide Availability Forecasts for the month covered by the report. If :
- (i) Seller did not comply with its availability forecasting requirements for any hour during the month; and
 - (ii) The Availability Deviation for such hour exceeds the Performance Tolerance Band (as defined below);

then Seller may be responsible for SCE Penalties as set forth below.

- (b) The Performance Tolerance Band, in MW, shall be equal to:
- (i) Three percent (3%) times the
 - (ii) Forecasted Available Capacity as set forth in the Availability Forecast for such hour.

2. SCE Penalty.

- (a) Subject to Sections 2(b) and 2(c) below, the SCE penalty amount shall be one hundred dollars per MW (\$100/MW) for each MW of Availability Deviation (including the Availability Deviation below the Performance Tolerance Band), or any portion thereof, in every hour for which the conditions in Section 1(a) have been met ("SCE Penalty").
- (b) Once in each month, the SCE Penalty will be waived for the first hour and any subsequent hours of the first day in which Seller fails to meet the requirements in Section 1(a) above.
- (c) The SCE Penalty will be assessed during any hour thereafter in that calendar month in which Seller fails to meet the requirements in Sections 1(a) and 1(b).

3. ISO Sanctions.

The contents of this document are subject to restrictions on disclosure as set forth herein.

Seller shall be liable to reimburse SCE for all ISO Sanctions incurred by SCE as a result of Seller's failure to adhere to its obligations under the ISO Tariff or any ISO directive, as such directive is communicated to Seller by SCE.

4. Billing and Documentation of ISO Sanctions.

- (a) The ISO Sanctions will be available for billing approximately one hundred twenty (120) days following the last day of a calendar month for electrical deliveries during that month or thirty (30) days after the ISO final settlement data is available to SCE for such deliveries, whichever is sooner.
- (b) SCE shall provide to Seller the applicable back-up data used for validating ISO Sanctions, including any relevant updated or adjusted information as it becomes available to SCE. This obligation shall survive the termination of this Power Purchase Agreement for twenty eight (28) months.

**** End of EXHIBIT R****

EXHIBIT S
Actual Availability Report

The contents of this document are subject to restrictions on disclosure as set forth herein.

EXHIBIT S

Actual Availability Report

Pursuant to Section 3.19, Seller shall prepare an Actual Availability Report in accordance with the procedures described in this Exhibit S.

1. Availability Workbook.

Seller shall (1) collect the measurement data, listed in Item 2 below, in one (1) or more Microsoft Excel Workbooks (the "Availability Workbook") provided in a form and naming convention approved by SCE and (2) electronically send the Availability Workbook to an address provided by SCE.

The Actual Availability Report shall reflect the sum of the Actual Available Capacity of all generators as measured by such generator's internal turbine controller.

2. Log of Availability.

The Availability Workbook shall be created on a single, dedicated worksheet and shall be in the form of Attachment 1 to this Exhibit S.

The data presented in the Availability Workbook shall not reflect any electric energy losses between the ISO Approved Meter and the Delivery Point.

EXHIBIT T

*Form of Subordinated Leasehold Deed of Trust, Security Agreement,
Assignment of Rents and Leases and Fixture Filing*

The contents of this document are subject to restrictions on disclosure as set forth herein.

EXHIBIT T

Form of Subordinated Leasehold Deed of Trust, Security Agreement, Assignment of Rents and Leases and Fixture Filing

**RECORDING REQUESTED BY,
AND WHEN RECORDED MAIL TO:**

**Southern California Edison Company
2244 Walnut Grove Avenue
Rosemead, California 91770
Attention: Manager, SCE Law Department
Power Procurement**

SPACE ABOVE THIS LINE RESERVED FOR RECORDER'S USE

**SUBORDINATED LEASEHOLD DEED OF TRUST, SECURITY AGREEMENT,
ASSIGNMENT OF RENTS AND LEASES AND FIXTURE FILING (CALIFORNIA)**

by and from

_____, "Grantor"

to

_____, "Trustee"

for the benefit of

**SOUTHERN CALIFORNIA EDISON COMPANY,
"Beneficiary"**

Effective as of _____, 20__

Municipality:

County:

State:

Kern

California

THIS SUBORDINATED DEED OF TRUST SECURES CERTAIN OBLIGATIONS OF THE GRANTOR UNDER THE POWER PURCHASE AGREEMENT (AS DEFINED HEREIN).

The contents of this document are subject to restrictions on disclosure as set forth herein.

THIS SUBORDINATED DEED OF TRUST IS SUBORDINATED TO THAT CERTAIN INTERCREDITOR AND SUBORDINATION AGREEMENT DATED AS OF _____ BETWEEN BENEFICIARY AND _____, AS SENIOR AGENT.

ATTENTION: COUNTY RECORDER: This Deed of Trust covers goods which are or are to become affixed to or fixtures on the leasehold estates in the land described in Exhibit A hereto and is to be filed for record in the records where deeds of trust on real estate are recorded. Additionally, this instrument should be appropriately indexed, not only as a deed of trust, but also as a Financing Statement covering goods that are or are to become fixtures on the real property described herein. The mailing addresses of the Grantor (Debtor) and Beneficiary (Secured Party) are set forth in the Preamble of this Deed of Trust.

**SUBORDINATED LEASEHOLD DEED OF TRUST, SECURITY AGREEMENT,
ASSIGNMENT OF RENTS AND LEASES AND FIXTURE FILING (CALIFORNIA)**

THIS SUBORDINATED LEASEHOLD DEED OF TRUST, SECURITY AGREEMENT, ASSIGNMENT OF RENTS AND LEASES AND FIXTURE FILING (CALIFORNIA) (as hereafter amended, modified, extended, restated, supplemented or renewed from time to time, the "**Deed of Trust**") is effective as of _____, 20__ by and from _____, a _____ limited liability company ("**Grantor**"), having an address at _____, to _____ ("**Trustee**"), having an address at _____, for the benefit of **SOUTHERN CALIFORNIA EDISON COMPANY**, having an address at 2244 Walnut Grove Avenue, Rosemead, California 91770 ("**SCE**" or "**Beneficiary**"). The term "**Grantor**" shall be synonymous with the term "**Trustor**" for purposes of California law.

RECITALS

A. SCE has entered into that certain **GENERATING FACILITY POWER PURCHASE AND SALE AGREEMENT** dated as of December _____, 20____, with _____, a _____ limited liability company, as "**Seller**" thereunder, pursuant to which Grantor has agreed, subject to the terms and conditions set forth therein, to directly or indirectly develop and construct a wind-powered electricity generating facility and sell or cause to be sold all electric energy produced by such wind-powered electricity generating facility as specified therein, together with certain related attributes and benefits, to SCE, and SCE has agreed, subject to the terms and conditions set forth therein, to purchase such electric energy with such related attributes and benefits (said Generating Facility Power Purchase Agreement, as it may hereafter be amended, restated, supplemented, substituted, replaced or otherwise modified from time to time, the "**Power Purchase Agreement**").

B. Pursuant to the Power Purchase Agreement, in order to induce SCE to enter into the Power Purchase Agreement, Grantor has agreed to execute and deliver this Deed of Trust.

**ARTICLE 1
DEFINITIONS**

Section 1.1. Definitions. All capitalized terms used herein without definition shall have the respective meanings ascribed to them in the Power Purchase Agreement. As used herein, the following terms shall have the following meanings:

(a) "**Event of Default**": shall have the meaning specified in the Power Purchase Agreement.

(b) "**Lien**": any lien, mortgage, deed of trust, pledge, assignment, security interest, charge or encumbrance of any kind (including any conditional sale or other title retention agreement, any lease in the nature thereof, and any agreement to give any security

The contents of this document are subject to restrictions on disclosure as set forth herein.

interest) and any option, trust or other preferential arrangement having the practical effect of any of the foregoing.

(c) **“Mortgaged Property”**: All of Grantor’s right, title and interest in and to the following: (1) the leasehold, easement interest or other right or interest in the real property described in Exhibit A attached hereto and incorporated herein by this reference, created by the Subject Leases (hereafter defined) together with any greater estate therein as hereafter may be acquired by Grantor, (the **“Land”**) together with all rights, privileges, tenements, hereditaments, rights-of-way, easements, appendages and appurtenances appertaining to the foregoing and all interests now or in the future arising in respect of, benefiting or otherwise relating to the Land, including, without limitation, easements, rights-of-way and development rights, including all right, title and interest now owned or hereafter acquired by Grantor in and to any land lying within the right of way of any street, open or proposed, adjoining the Land, and any and all sidewalks, alleys, driveways, and strips and gores of land adjacent to or used in connection with the Land (which, together with the Land, are collectively referred to as the **“Real Property”**); (2) all improvements now owned or hereafter acquired by Grantor, now or at any time situated, placed or constructed upon the Land, including any improvements designed, intended or actually used in connection with the generation, storage, modification, transmission or distribution of electrical energy (the **“Improvements”**); (3) all fixtures, machinery, appliances, goods, building or other materials, equipment, including all machinery, equipment, engines, appliances and fixtures for generating or distributing air, water, heat, electricity, light, sewage, fuel or refrigeration, or for ventilating or sanitary purposes, the exclusion of vermin or insects, or the removal of dust, refuse or garbage, wind turbines, transmission and gathering lines and towers, electrical substations, control and storage facilities, communications towers, facilities and equipment, and all extensions, additions, accessions, improvements, betterments, renewals, substitutions, and replacements to any of the foregoing, which, to the fullest extent permitted by law, shall be conclusively deemed fixtures and improvements and a part of the real property hereby encumbered (the **“Fixtures”**) (the Real Property, Improvements and Fixtures are collectively referred to as the **“Premises”**); (4) all leases, licenses, concessions, occupancy agreements or other agreements (written or oral, now or at any time in effect) which grant to any Person a possessory interest in, or the right to use, all or any part of the Premises, together with all related security and other deposits (the **“Leases”**); (5) all of the rents, revenues, royalties, income, proceeds, profits, security and other types of deposits, and other benefits paid or payable in connection with the use or operation of the Premises for using, leasing, licensing, possessing, operating from, residing in, selling or otherwise enjoying the Premises or any Improvements thereon (the **“Rents”**); (6) all accessions, replacements and substitutions for any of the foregoing and all proceeds from the sale, disposition or transfer thereof (the **“Proceeds”**); (7) all insurance policies, unearned premiums therefor and proceeds from such policies covering any of the above property now or hereafter acquired by Grantor (the **“Insurance”**); (8) all contract rights, options, entitlements, permits and other agreements or rights relating to the Premises or the right to acquire, lease, occupy and/or use the Premises, the Leases, or any portion thereof (**“Contract Rights”**) and (9) all awards, damages, remunerations, reimbursements, settlements or compensation heretofore made or hereafter to be made by any governmental authority pertaining to the Premises (the **“Condemnation Awards”**). As used in this Deed of Trust, the term

The contents of this document are subject to restrictions on disclosure as set forth herein.

“Mortgaged Property” means all or, where the context permits or requires, any portion of the above or any interest therein.

(d) **“Obligations”**: Grantor’s obligation to make any **“Termination Payment”** (as such term is defined in the Power Purchase Agreement) as such obligation may be extended, reduced or modified in accordance with the Power Purchase Agreement. This Deed of Trust does not secure any obligations under the Power Purchase Agreement other than the obligation to make Termination Payments. Notwithstanding anything to the contrary herein or in the Power Purchase Agreement, the maximum amount of the Obligations secured hereby shall not exceed the sum of (i) the Termination Payment plus (ii) any costs incurred to protect the lien and rights created by this Deed of Trust, to enforce the terms of this Deed Of Trust or to foreclose this Deed of Trust against any or all of the Mortgaged Property.

(e) **“Permitted Encumbrances”** any “Permitted Lien” as defined in the Power Purchase Agreement, provided that for the purposes of this Deed of Trust (and no other purpose) the term Permitted Lien is modified to the extent that: (A) clauses (c), (d) and (f) of the definition of Permitted Lien are deemed to refer only to matters in existence prior to the date of the recording of this Deed of Trust, and (B) the definition of the term Permitted Lien shall be deemed to include all easements, rights, facilities and/or improvements constructed, installed or granted in connection with development of the Generating Facility contemplated by the Power Purchase Agreement.

(f) **“Required Priority”**: With respect to the Lien created in the Mortgaged Property or any portion thereof pursuant to this Deed of Trust, (1) such Lien has priority over any other Lien on the Mortgaged Property other than a Senior Lien and Permitted Encumbrances and (ii) such Lien is the only Lien (other than any Senior Liens and Permitted Encumbrances) to which the Mortgaged Property is subject, unless otherwise permitted under the Power Purchase Agreement or approved by Beneficiary in its sole discretion.

(g) **“Senior Lien”** means any Lien to which this Deed of Trust is required to be subordinated pursuant to the terms of the Power Purchase Agreement.

(h) **“Subject Lease”**: All of the real property leases, easement agreements, licenses, option agreements and other Leases or Contract Rights, now or in the future described on Exhibit A attached hereto and incorporated herein by this reference, and all amendments, extensions, assignments and modifications thereto.

(i) **“UCC”**: The Uniform Commercial Code in the State of California. If the creation, perfection and enforcement of any security interest herein granted is governed by the laws of a state other than California, then, as to the matter in question, the term “UCC” means the Uniform Commercial Code in effect in that state.

ARTICLE 2
GRANT

Section 2.1. Grant. To secure the full and timely performance of the Obligations, Grantor **GRANTS, BARGAINS, ASSIGNS, SELLS and CONVEYS**, to Trustee the Mortgaged Property, subject, however, to the Permitted Encumbrances, **TO HAVE AND TO HOLD** the Mortgaged Property, **IN TRUST, WITH POWER OF SALE**, and Grantor does hereby bind itself, its successors and assigns to **WARRANT AND FOREVER DEFEND** the title to the Mortgaged Property unto Trustee.

ARTICLE 3
WARRANTIES, REPRESENTATIONS AND COVENANTS

Grantor warrants, represents and covenants to Beneficiary as follows:

Section 3.1. Lien Status. Grantor shall preserve and protect the Required Priority of this Deed of Trust. If any Lien or security interest other than a Senior Lien or a Permitted Encumbrance is asserted against the Mortgaged Property that has priority over this Deed of Trust but is not a Senior Lien or a Permitted Encumbrance, Grantor shall promptly, and at its expense, (a) give Beneficiary a detailed written notice of such Lien or security interest (including origin, amount and other terms), and (b) pay the underlying claim in full or take such other action so as to cause it to be released or contest the same in compliance with the requirements of the Power Purchase Agreement and this Deed of Trust (including any requirement to provide a bond or other security satisfactory to Beneficiary).

Section 3.2. Performance. Grantor shall perform the Obligations in full when they are required to be performed.

Section 3.3. Replacement of Fixtures. Grantor shall not, without the prior written consent of Beneficiary, which consent shall not be unreasonably withheld, conditioned or delayed so long as no Event of Default has occurred and is continuing, permit any of the Fixtures owned or leased by Grantor to be removed at any time from the Real Property or Improvements, unless (a) the removed item is removed temporarily for maintenance and repair, or replacement, (b) if removed in accordance with the Power Purchase Agreement, or (c) otherwise pursuant to Beneficiary's prior written consent, which consent shall not be unreasonably withheld, conditioned or delayed so long as no Event of Default has occurred and is continuing.

Section 3.4. Inspections and Audits. Grantor shall permit reasonable inspections of the Mortgaged Property by Beneficiary upon reasonable prior written notice to Grantor by Beneficiary.

Section 3.5. Other Covenants. All of the covenants of Grantor and any Affiliate of Grantor in the Power Purchase Agreement or any document executed in connection therewith, to the extent applicable to the Mortgaged Property, are incorporated herein by this reference and are hereby made by Grantor with respect to the Mortgaged Property. Such covenants, together with covenants in this Article 3, are covenants running with the Land.

The contents of this document are subject to restrictions on disclosure as set forth herein.

Section 3.6. Condemnation Awards and Insurance Proceeds.

(a) Condemnation Awards. Grantor assigns all awards and compensation to which it is entitled for any condemnation or other taking, or any purchase in lieu thereof, to Beneficiary and authorizes Beneficiary to collect and receive such awards and compensation and to give proper receipts and acquittances therefor in accordance with the terms of the Power Purchase Agreement. From and after the occurrence and during the continuance of an Event of Default, all proceeds of any such condemnation or other taking shall be directly disbursed to Beneficiary or promptly distributed to Beneficiary if received by Grantor or Trustee.

(b) Insurance Proceeds. Grantor assigns to Beneficiary all proceeds of any insurance policies insuring against loss or damage to the Mortgaged Property. Grantor authorizes Beneficiary to collect and receive such proceeds and authorizes and directs the issuer of each of such insurance policies to make payment for all such losses directly to Beneficiary, instead of to Grantor and Beneficiary jointly. From and after the occurrence and during the continuance of an Event of Default, all such proceeds shall be directly disbursed to Beneficiary or promptly distributed to Beneficiary if received by Grantor or Trustee.

Section 3.7. Peaceable Possession. Grantor's possession of the Mortgaged Property has been peaceable and, as of the date hereof, undisturbed and the Grantor does not know of any facts by reason of which any adverse claim to any part of the Mortgaged Property or to any undivided interest therein might be set up or made.

Section 3.8. Taxes.

(a) Grantor shall pay, when due and prior to delinquency, all Taxes imposed or levied by any Government Authority which create a Lien upon the Mortgaged Property or any part thereof (all of which Taxes are hereinafter referred to as "**Impositions**"). If by law any such Imposition is payable, or may at the option of the taxpayer be paid, in installments, Grantor may pay the same, together with any accrued interest on the unpaid balance of such Imposition, in installments as the same become due and before any fine, penalty, interest or cost may be added thereto for the nonpayment of any such installment and interest. If at any time after the date hereof there shall be assessed or imposed a license fee, tax or assessment on Beneficiary which is measured by or based in whole or in part upon the amount of the outstanding Obligations (excluding income, excise or similar taxes), then all such Taxes shall be deemed to be included within the term "Impositions" as defined herein, and Grantor shall pay and discharge the same as herein provided with respect to the payment of Impositions, or, if Grantor shall not be permitted by law to pay and discharge such Imposition either directly or indirectly, then, at the option of Beneficiary, all obligations secured hereby, together with all interest thereon, shall become immediately due and payable.

(b) Grantor has the right, before any delinquency occurs, to contest or object to the amount or validity of any Imposition by appropriate legal proceedings, but this right shall not be deemed or construed in any way as relieving, modifying or postponing Grantor's obligation to pay any such Imposition at the time and in the manner provided herein, unless (i) Grantor has given prior written notice to Beneficiary of Grantor's intent so to contest or object to

The contents of this document are subject to restrictions on disclosure as set forth herein.

an Imposition; (ii) Grantor has demonstrated to Beneficiary's satisfaction that the legal proceedings shall conclusively operate to prevent the sale of the Mortgaged Property, or any part thereof, to satisfy such Imposition prior to a final determination of such proceedings; and (iii) Grantor has, or has caused to be, provided such deposit, payment, security, reserve or other appropriate provision, if any, as shall be required by the appropriate taxing authority.

Section 3.9. Utilities. Grantor shall pay, when due, all utility charges incurred by Grantor for the benefit of the Mortgaged Property, or which may become a charge or Lien against the Mortgaged Property, for gas, electricity, water, sewer and all other utility services furnished to the Mortgaged Property, and all other assessments or charges of a similar nature, whether public or private, affecting the Mortgaged Property or any portion thereof, whether or not such assessments or charges are Liens thereon.

ARTICLE 4 **LEASEHOLD PROVISIONS**

Section 4.1. Representations; Warranties; Covenants. Grantor hereby represents, warrants and covenants that:

(a) (1) Each Subject Lease is unmodified and, to the best of Grantor's knowledge, in full force and effect, (2) all rent, fees and other charges thereunder have been paid to the extent they are payable to the date hereof, (3) to the extent that any Subject Lease creates a possessory estate, Grantor enjoys the quiet and peaceful possession of the property demised thereby, (4) to the best of its knowledge, Grantor is not in default under any of the terms thereof and there are no circumstances which, with the passage of time or the giving of notice or both, would constitute such a default by the Grantor thereunder, (5) to the best of Grantor's knowledge, the lessor or grantor thereunder is not in default under any of the terms or provisions thereof on the part of the lessor or grantor to be observed or performed.

(b) Grantor shall promptly pay, when due and payable, the rent, fees and other charges payable pursuant to each Subject Lease, and will timely perform and observe in all material respects all of the other terms, covenants and conditions required to be performed and observed by Grantor as lessee or grantee under each Subject Lease. Nothing in this Deed of Trust or the Power Purchase Agreement shall be construed as requiring Grantor, Trustee or Beneficiary to exercise any option, right or similar agreement to lease or acquire real property granted to Beneficiary as collateral hereunder.

(c) Grantor shall notify Beneficiary in writing of any material default by Grantor in the performance or observance of any terms, covenants or conditions on the part of Grantor to be performed or observed under any Subject Lease within three (3) Business Days after Grantor knows of such default.

(d) Grantor shall, immediately upon receipt thereof, deliver a copy of each notice of default given to Grantor by the lessor or grantor pursuant to a Subject Lease and promptly notify Beneficiary in writing of any material default by the lessor or grantor in the

The contents of this document are subject to restrictions on disclosure as set forth herein.

performance or observance of any of the terms, covenants or conditions on the part of the lessor or grantor to be performed or observed thereunder.

(e) Unless expressly required under the terms of a Subject Lease, Grantor shall not, without the prior written consent of Beneficiary (which may be granted or withheld in Beneficiary's sole and absolute discretion) terminate, materially modify or amend, surrender or let lapse any Subject Lease (except by the passage of time in accordance with its terms), and any such attempted termination, modification, amendment or surrender without Beneficiary's written consent shall be void.

(f) Grantor shall, within twenty (20) Business Days after written request from Beneficiary, use its commercially reasonable efforts to obtain from the lessor or grantor and deliver to Beneficiary a certificate setting forth the name of the tenant/grantee thereunder and stating that the Subject Lease is in full force and effect, is unmodified or, if the Subject Lease has been modified, the date of each modification (together with copies of each such modification), that no notice of termination thereon has been served on Grantor, stating that to lessor's knowledge, no default or event which with notice or lapse of time (or both) would become a default is existing under the Subject Lease, stating the date to which all rent, fees or other charges have been paid, and specifying the nature of any defaults, if any, and containing such other statements and representations as may be reasonably requested by Beneficiary.

Section 4.2. No Merger. So long as any of the Obligations remain unperformed, the fee title to and the leasehold or easement estate in the Premises subject to a Subject Lease shall not merge but shall always be kept separate and distinct notwithstanding the union of such estates in the lessor (except in the event of the expiration of a Subject Lease in accordance with its terms) or Grantor, or in a third party, by purchase or otherwise. If Grantor acquires the fee title or any other estate, title or interest in the property demised by a Subject Lease, or any part thereof, the Lien of this Deed of Trust shall attach to, cover and be a Lien upon such acquired estate, title or interest and the same shall thereupon be and become a part of the Mortgaged Property with the same force and effect as if specifically encumbered herein. Grantor agrees to execute all instruments and documents that Beneficiary or Trustee may reasonably require to ratify, confirm and further evidence the Lien of this Deed of Trust on the acquired estate, title or interest. Furthermore, Grantor hereby appoints Beneficiary as its true and lawful attorney-in-fact for the purpose of executing and delivering, following and during the continuance of an Event of Default, all such instruments and documents in the name and on behalf of Grantor. This power, being coupled with an interest, shall be irrevocable as long as any Obligation remains unperformed.

Section 4.3. Beneficiary as Lessee. If a Subject Lease is terminated or expires prior to the natural expiration of its term due to default by Grantor or any tenant thereunder, and if Beneficiary or its designee acquires from the lessor a new lease of the premises, Grantor shall have no right, title or interest in or to such new lease or the leasehold estate created thereby, or renewal privileges therein contained.

Section 4.4. No Assignment. If this Deed of Trust constitutes a prohibited collateral assignment of a Subject Lease under the terms of the Subject Lease, then the assignment of the

The contents of this document are subject to restrictions on disclosure as set forth herein.

Subject Lease in this Deed of Trust will be deemed conditioned upon the receipt of any consent expressly required under the Subject Lease and Beneficiary has no liability or obligation thereunder by reason of its acceptance of this Deed of Trust. Beneficiary will be liable for the obligations of the tenant/grantee arising out of the Subject Lease for only that period of time for which Beneficiary is in possession of the Premises or have acquired, by foreclosure or otherwise, and are holding all of Grantor's right, title and interest therein.

Section 4.5. Renewal Not Required. Nothing in this Deed of Trust shall be construed to require Beneficiary to exercise any renewal, extension or similar options under the Subject Lease upon the natural expiration of the current term thereof.

ARTICLE 5

DEFAULT AND FORECLOSURE

Section 4.1. Remedies. If a Termination Payment or any portion thereof has not been paid as provided in the Power Purchase Agreement (a "**Termination Payment Default**"), Beneficiary may, at Beneficiary's election and by or through Trustee or otherwise, exercise any or all of the following rights, remedies and recourses subject to any requirements or limitations expressly set forth in the Power Purchase Agreement:

(a) Acceleration. Declare the Obligations to be immediately due and payable, without further notice, presentment, protest, notice of intent to accelerate, notice of acceleration, demand or action of any nature whatsoever (each of which hereby is expressly waived by Grantor), whereupon the same shall become immediately due and payable.

(b) Entry on Mortgaged Property. Enter the Mortgaged Property and take exclusive possession thereof and of all books, records and accounts relating thereto or located thereon. If Grantor remains in possession of the Mortgaged Property after a Termination Payment Default and without Beneficiary's prior written consent, Beneficiary may invoke any legal remedies to dispossess Grantor.

(c) Operation of Mortgaged Property. Subject to the terms of a Subject Lease, hold, lease, develop, manage, operate or otherwise use the Mortgaged Property upon such terms and conditions as Beneficiary may deem reasonable under the circumstances (making such repairs, alterations, additions and improvements and taking other actions, from time to time, as Beneficiary reasonably deems necessary or desirable except as provided in a Subject Lease), and apply all Rents and other amounts collected by Trustee in connection therewith in accordance with the provisions of Section 5.7, below and the Power Purchase Agreement, as applicable.

(d) Foreclosure and Sale. Institute proceedings for the complete foreclosure of this Deed of Trust, either by judicial action or by power of sale, in which case the Mortgaged Property may be sold for cash or credit in one or more parcels as Beneficiary may determine. With respect to any notices required or permitted under the UCC, Grantor agrees that ten (10) days prior written notice shall be deemed commercially reasonable. At any such sale by virtue of any judicial proceedings, power of sale, or any other legal right, remedy or recourse, the title

The contents of this document are subject to restrictions on disclosure as set forth herein.

to and right of possession of any such property shall pass to the purchaser thereof, and to the fullest extent permitted by law, Grantor shall be completely and irrevocably divested of all of its right, title, interest, claim, equity, equity of redemption, and demand whatsoever, either at law or in equity, in and to the property sold and such sale shall be a perpetual bar both at law and in equity against Grantor, and against all other Persons claiming or to claim the property sold or any part thereof, by, through or under Grantor. Beneficiary may be a purchaser at such sale. In the event this Deed of Trust is foreclosed by judicial action, appraisal of the Mortgaged Property is waived.

(e) Receiver. Make application to a court of competent jurisdiction for, and obtain from such court as a matter of strict right and without notice to Grantor or regard to the adequacy of the Mortgaged Property for the payment and performance of the Obligations, the appointment of a receiver of the Mortgaged Property, and Grantor irrevocably consents to such appointment. Any such receiver shall have all the usual powers and duties of receivers in similar cases, including the full power to rent, maintain and otherwise operate the Mortgaged Property upon such terms as may be approved by the court, and shall apply such Rents in accordance with the provisions of Section 5.7, below and the Power Purchase Agreement, as applicable.

(f) Other. Exercise all other rights, remedies and recourses granted under the Power Purchase Agreement or otherwise available at law or in equity.

Section 5.2. Separate Sales. The Mortgaged Property may be sold in one or more parcels and in such manner and order as Trustee in its sole discretion may elect; the right of sale arising out of any Termination Payment Default shall not be exhausted by any one or more sales.

Section 5.3. Remedies Cumulative, Concurrent and Nonexclusive. Beneficiary and Trustee shall have all rights, remedies and recourses granted in the Power Purchase Agreement and available at law or equity (including the UCC), which rights (a) shall be cumulated and concurrent, (b) may be pursued separately, successively or concurrently against Grantor or others obligated under the Power Purchase Agreement, or against the Mortgaged Property, or against any one or more of them, at the sole discretion of Beneficiary or Trustee, as the case may be, (c) may be exercised as often as occasion therefor shall arise, and the exercise or failure to exercise any of them shall not be construed as a waiver or release thereof or of any other right, remedy or recourse, and (d) are intended to be, and shall be, nonexclusive. No action by Beneficiary or Trustee in the enforcement of any rights, remedies or recourses under the Power Purchase Agreement or otherwise at law or equity shall be deemed to cure any Termination Payment Default or other Event of Default.

Section 5.4. Release of and Resort to Collateral. Beneficiary may release, regardless of consideration and without the necessity for any notice to or consent by the holder of any subordinate Lien on the Mortgaged Property, any part of the Mortgaged Property without, as to the remainder, in any way impairing, affecting, subordinating or releasing the Lien or security interest created in or evidenced by the Power Purchase Agreement or their status as a first and prior Lien and security interest in and to the Mortgaged Property. For payment and performance of the Obligations, Beneficiary may resort to any other security in such order and manner as Beneficiary may elect.

The contents of this document are subject to restrictions on disclosure as set forth herein.

Section 5.5. Waiver of Redemption, Notice and Marshalling of Assets. To the fullest extent permitted by law, Grantor hereby irrevocably and unconditionally waives and releases (a) all benefit that might accrue to Grantor by virtue of any present or future statute of limitations or law or judicial decision exempting the Mortgaged Property from attachment, levy or sale on execution or providing for any stay of execution, exemption from civil process, redemption or extension of time for payment, (b) all notices of any Termination Payment Default or any other Event of Default or of any election by Trustee or Beneficiary to exercise or the actual exercise of any right, remedy or recourse provided for under the Power Purchase Agreement, and (c) any right to a marshalling of assets or a sale in inverse order of alienation.

Section 5.6. Discontinuance of Proceedings. If Beneficiary or Trustee shall have proceeded to invoke any right, remedy or recourse permitted under the Power Purchase Agreement and shall thereafter elect to discontinue or abandon it for any reason, Beneficiary or Trustee, as the case may be, shall have the unqualified right to do so and, in such an event, Grantor, Beneficiary or Trustee shall be restored to their former positions with respect to the Obligations, the Power Purchase Agreement, the Mortgaged Property and otherwise, and the rights, remedies, recourses and powers of Beneficiary or Trustee shall continue as if the right, remedy or recourse had never been invoked, but no such discontinuance or abandonment shall waive any Termination Payment Default or any other Event of Default which may then exist or the right of Beneficiary or Trustee thereafter to exercise any right, remedy or recourse under the Power Purchase Agreement for such Termination Payment Default or any other Event of Default.

Section 5.7. Application of Proceeds. The proceeds of any sale of, and the Rents and other amounts generated by the holding, leasing, management, operation or other use of the Mortgaged Property, shall be disbursed to Beneficiary by Trustee (or the receiver, if one is appointed) in accordance with the Power Purchase Agreement and applicable law, including California Civil Code Section 2924k.

Section 5.8. Occupancy After Foreclosure. Any sale of the Mortgaged Property or any part thereof in accordance with Section 5.1(d) will divest all right, title and interest of Grantor in and to the property sold. Subject to applicable law, any purchaser at a foreclosure sale will receive immediate possession of the property purchased. If Grantor retains possession of such property or any part thereof subsequent to such sale, Grantor will be considered a tenant at sufferance of the purchaser, and will, if Grantor remains in possession after demand to remove, be subject to eviction and removal, forcible or otherwise, with or without process of law.

Section 5.9. Additional Advances and Disbursements; Costs of Enforcement.

(a) If any Termination Payment Default has occurred and is continuing, Beneficiary shall have the right, but not the obligation, to cure such Termination Payment Default in the name and on behalf of Grantor. All sums advanced and reasonable expenses incurred at any time by Beneficiary under this Section 5.9, or otherwise under this Deed of Trust or the Power Purchase Agreement or applicable law, shall bear interest from the date that such sum is advanced or expense incurred, to and including the date of reimbursement, computed at

The contents of this document are subject to restrictions on disclosure as set forth herein.

the Simple Interest Rate, and all such sums, together with interest thereon, shall be secured by this Deed of Trust.

(b) Grantor shall pay all reasonable expenses (including reasonable attorneys' fees and expenses) of or incidental to the enforcement of this Deed of Trust and the Power Purchase Agreement, or the enforcement, compromise or settlement of the Obligations or any claim under this Deed of Trust and the Power Purchase Agreement, and for the curing thereof, or for defending or asserting the rights and claims of Beneficiary in respect thereof, by litigation or otherwise.

Section 5.10. No Mortgagee in Possession. Neither the enforcement of any of the remedies under this Article 5, the assignment of the Rents and Leases under Article 6, the security interests under Article 7, nor any other remedies afforded to Beneficiary under the Power Purchase Agreement, at law or in equity shall cause Beneficiary or Trustee to be deemed or construed to be a mortgagee in possession of the Mortgaged Property, to obligate Beneficiary or Trustee to lease the Mortgaged Property or attempt to do so, or to take any action, incur any expense, or perform or discharge any obligation, duty or liability whatsoever under any of the Leases or otherwise.

Section 5.11. Actions by Beneficiary to Preserve the Mortgaged Property. If Grantor fails to make any payment or do any act as and in the manner required by this Deed of Trust or the Power Purchase Agreement, Beneficiary, in its sole and absolute discretion, without obligation so to do and without notice to or demand upon Grantor and without releasing Grantor from any obligation, may make such payment or do such act in such manner and to such extent as Beneficiary may deem necessary to protect the security hereof. In connection therewith (without limiting Beneficiary's general powers), if a Termination Payment Default has occurred and is continuing, and subject to any express requirements or limitations expressly set forth in the Power Purchase Agreement, the Beneficiary shall have and is hereby given the right, but not the obligation, (i) to enter upon and take possession of the Mortgaged Property; (ii) to make additions, alterations, repairs and Improvements to the Mortgaged Property which it may consider necessary or proper to keep the Mortgaged Property in good condition and repair; (iii) to appear and participate in any action or proceeding which affects or may affect the security hereof or the rights or powers of Beneficiary; (iv) to pay, purchase, contest or compromise any encumbrance, claim, charge, Lien or debt which, in Beneficiary's judgment, may affect or appear to affect the security of this Deed of Trust; and (v) in exercising such powers, to employ counsel or other necessary or desirable experts or consultants. Grantor shall, immediately upon demand therefor by Beneficiary, pay all reasonable costs and expenses incurred by Beneficiary in connection with the exercise by Beneficiary of the foregoing rights, including cost of evidence of title, court costs, appraisals, surveys, and reasonable attorneys' fees, together with interest thereon from the date incurred at the Simple Interest Rate. All such costs and expenses together with interest thereon shall be secured by this Deed of Trust.

Section 5.12. Due On Sale. In order to induce Beneficiary to enter into the Power Purchase Agreement, Grantor agrees that, except as otherwise expressly permitted pursuant to the Power Purchase Agreement, in the event of any "transfer" of the Mortgaged Property or any portion thereof without the prior written consent of Beneficiary, Beneficiary has the absolute

The contents of this document are subject to restrictions on disclosure as set forth herein.

right at its option, without prior demand or notice, to declare all sums secured by this Deed of Trust immediately due and payable. Consent to one such transaction will not be deemed to be a waiver of the right to require consent to future or successive transactions. Beneficiary may grant or deny such consent in its sole discretion and, if consent is given, any such transfer will be subject to this Deed of Trust, and any such transferee shall assume all obligations hereunder and agree to be bound by all provisions contained herein. Such assumption will not, however, release Grantor or any maker or guarantor of the Obligations from any liability thereunder without the prior written consent of Beneficiary. As used herein, “**transfer**” includes the direct or indirect sale, agreement to sell, transfer, conveyance, pledge, collateral assignment or hypothecation of the Mortgaged Property, or any portion thereof or interest therein, whether voluntary, involuntary, by operation of law or otherwise, the execution of any installment land sale contract or similar instrument affecting all or a portion of the Mortgaged Property, or the lease or sublease of all or any portion of the Mortgaged Property. The term “**transfer**” also includes a change in Control in Grantor. Notwithstanding any statements to the contrary, “**transfer**” shall not include an assignment of any right, title and interest in and to a portion of the Mortgaged Property by Grantor that is permitted under or authorized by the Power Purchase Agreement.

ARTICLE 6
ASSIGNMENT OF RENTS AND LEASES

Section 6.1. Assignment. In furtherance of and in addition to the assignment made by Grantor in Section 2.1 of this Deed of Trust, Grantor hereby absolutely and unconditionally assigns, sells, transfers and conveys to Trustee (for the benefit of Beneficiary) and to Beneficiary all of its right, title and interest in and to all Leases, whether now existing or hereafter entered into, and all of its right, title and interest in and to all Rents. This assignment is an absolute assignment and not an assignment for additional security only. So long as no Termination Payment Default shall have occurred and be continuing, Grantor shall have a revocable license from Trustee and Beneficiary to exercise all rights extended to the landlord under the Leases, including the right to receive and collect all Rents and to hold the Rents in trust for use in the payment and performance of the Obligations and to otherwise use the same. The foregoing license is granted subject to the conditional limitation that no Termination Payment Default shall have occurred and be continuing. Upon the occurrence and during the continuance of a Termination Payment Default and upon written notice from Beneficiary to Grantor, whether or not legal proceedings have commenced, and without regard to waste, adequacy of security for the Obligations or solvency of Grantor, the license herein granted shall automatically expire and terminate, without notice to Grantor by Trustee or Beneficiary (any such notice being hereby expressly waived by Grantor to the extent permitted by applicable law).

Section 6.2. Perfection Upon Recordation. Grantor acknowledges that Beneficiary and Trustee have taken all actions necessary to obtain, and that upon recordation of this Deed of Trust, Beneficiary and Trustee shall have, to the extent permitted under applicable law, a valid and fully perfected, First Priority, present assignment of the Rents arising out of the Leases and all security for such Leases. Grantor acknowledges and agrees that upon recordation of this Deed of Trust Trustee’s and Beneficiary’s interest in the Rents shall be deemed to be fully

The contents of this document are subject to restrictions on disclosure as set forth herein.

perfected, "choate" and enforced as to Grantor and to the extent permitted under applicable law, all third parties, including, without limitation, any subsequently appointed trustee in any case under Title 11 of the United States Code (the "**Bankruptcy Code**"), without the necessity of commencing a foreclosure action with respect to this Deed of Trust, making formal demand for the Rents, obtaining the appointment of a receiver or taking any other affirmative action.

Section 6.3. Bankruptcy Provisions. Without limitation of the absolute nature of the assignment of the Rents hereunder, Grantor, Trustee and Beneficiary agree that (a) this Deed of Trust shall constitute a "security agreement" for purposes of Section 552(b) of the Bankruptcy Code, (b) the security interest created by this Deed of Trust extends to property of Grantor acquired before the commencement of a case in bankruptcy and to all amounts paid as Rents and (c) such security interest shall extend to all Rents acquired by the estate after the commencement of any case in bankruptcy.

Section 6.4. No Merger of Estates. So long as part of the Obligations secured hereby remain unpaid and undischarged, the fee and leasehold estates to the Mortgaged Property shall not merge, but shall remain separate and distinct, notwithstanding the union of such estates either in Grantor, Beneficiary, any tenant or any third party by purchase or otherwise (except in the event of the natural expiration of the Subject Lease pursuant to the term thereof).

ARTICLE 7

SECURITY AGREEMENT

Section 7.1. Security Interest. This Deed of Trust constitutes a "security agreement" on personal property within the meaning of the UCC and other applicable law and with respect to the Mortgaged Property. To this end, Grantor grants to Beneficiary a First Priority security interest in the Mortgaged Property which is personal property to secure the performance of the Obligations, and agrees that Beneficiary shall have all the rights and remedies of a secured party under the UCC with respect to such property. Any notice of sale, disposition or other intended action by Beneficiary with respect to the Mortgaged Property which is personal property sent to Grantor at least ten (10) days prior to any action under the UCC shall constitute reasonable notice to Grantor.

Section 7.2. Financing Statements. Grantor hereby authorizes Beneficiary to file such financing statements (and amendments thereto and continuations thereof) and hereby agrees to execute and deliver to Beneficiary, in form and substance reasonably satisfactory to Beneficiary such further assurances as Beneficiary may, from time to time, reasonably consider necessary to create, perfect and preserve Beneficiary's security interest hereunder and Beneficiary may cause such statements and assurances to be recorded and filed, at such times and places as may be required or permitted by law to so create, perfect and preserve such security interest. Grantor is a limited liability company, duly organized under the laws of the state of Delaware and, except as otherwise expressly provided in the Power Purchase Agreement, shall not change the state of its organization without less than twenty (20) days prior written notice to Beneficiary.

The contents of this document are subject to restrictions on disclosure as set forth herein.

Section 7.3. Fixture Filing. This Deed of Trust shall also constitute a “fixture filing” for the purposes of the UCC against all of the Mortgaged Property which is or is to become fixtures. For purposes of the UCC, the following information concerning the security interest herein granted is furnished:

(a) The name of the Debtor (Grantor) is _____, a _____ limited liability company, having an address as set forth in the first paragraph of this Deed of Trust, whose organizational number is _____.

(b) The name of the Secured Party (Beneficiary) is: **SOUTHERN CALIFORNIA EDISON COMPANY**, having an address as set forth in the first paragraph of this Deed of Trust.

(c) Information concerning the security interest evidenced by this instrument may be obtained from the Secured Party at its address above.

(d) The name and address of the record owner of the real estate described in this Security Instrument is listed on Exhibit A and Exhibit B hereto.

(e) This document is to be filed in the real estate records. A description of the real estate is attached hereto as Exhibit A.

ARTICLE 8
CONCERNING THE TRUSTEE

Section 8.1. Certain Rights. At any time, or from time to time, without liability therefor and without notice, upon written request of Beneficiary and presentation of this Deed of Trust and without affecting any personal liability of any person for payment or performance of the Obligations or the effect of this Deed of Trust upon the remainder of the Mortgaged Property, Trustee may (i) reconvey any part of the Mortgaged Property, (ii) consent in writing to the making of any map or plat thereof, (iii) join in granting any easement thereon, or (iv) join in any extension agreement or any agreement subordinating the Lien or charge hereof. With the approval of Beneficiary, Trustee shall have the right to select, employ and consult with counsel. Trustee shall have the right to rely on any instrument, document or signature authorizing or supporting any action taken or proposed to be taken by it hereunder, believed by it in good faith to be genuine. Trustee shall be entitled to reimbursement for actual, reasonable expenses incurred by it in the performance of its duties. Grantor shall, from time to time, pay the compensation due to Trustee hereunder and reimburse Trustee for, and indemnify, defend and save Trustee harmless against, all liability and reasonable expenses which may be incurred by it in the performance of its duties, including those arising from joint, concurrent, or comparative negligence of Trustee; however, Grantor shall not be liable under such indemnification to the extent such liability or expenses result solely from Trustee’s gross negligence or willful misconduct. Grantor’s obligations under this Section 8.1 shall not be reduced or impaired by principles of comparative or contributory negligence.

The contents of this document are subject to restrictions on disclosure as set forth herein.

Section 8.2. Retention of Money. All moneys received by Trustee shall, until used or applied as herein provided, be held in trust for the purposes for which they were received, but need not be segregated in any manner from any other moneys (except to the extent required by law), and Trustee shall be under no liability for interest on any moneys received by Trustee hereunder.

Section 8.3. Successor Trustees. If Trustee or any successor Trustee shall die, resign or become disqualified from acting in the execution of this trust, or Beneficiary shall desire to appoint a substitute Trustee, Beneficiary shall have full power to appoint one or more substitute Trustees and, if preferred, several substitute Trustees in succession who shall succeed to all the estates, rights, powers and duties of Trustee. Such appointment may be executed by any authorized agent of Beneficiary and as so executed, such appointment shall be conclusively presumed to be executed with authority, valid and sufficient, without further proof of any action. Trustee shall be deemed to have accepted appointment of this instrument when this instrument is recorded, and any successor shall be deemed to have accepted appointment when the notice of substitution is recorded. Without limitation of the foregoing, Beneficiary may, from time to time, by a written instrument executed and acknowledged by Beneficiary, recorded in the county in which the Mortgaged Property is located or by otherwise complying with the provisions of applicable law, substitute a successor or successors to any Trustee named herein or acting hereunder, and such successor(s) shall, without conveyance from the predecessor Trustee, succeed to all title, estate, rights, powers and duties of such predecessor.

Section 8.4. Perfection of Appointment. Should any deed, conveyance or instrument of any nature be required from Grantor by any successor Trustee to more fully and certainly vest in and confirm to such successor Trustee such estates, rights, powers and duties, then, upon request by such Trustee, all such deeds, conveyances and instruments shall be made, executed, acknowledged and delivered and shall be caused to be recorded and/or filed by Grantor.

Section 8.5. Trustee Liability. In no event or circumstance shall Trustee or any substitute Trustee hereunder be personally liable under or as a result of this Deed of Trust, either as a result of any action by Trustee (or any substitute Trustee) in the exercise of the powers hereby granted or otherwise.

ARTICLE 9 **MISCELLANEOUS**

Section 9.1. Notices. Any notice required or permitted to be given under this Deed of Trust shall be given in accordance with the Power Purchase Agreement.

Section 9.2. Covenants Running with the Land. All Obligations contained in this Deed of Trust are intended by Grantor, Beneficiary and Trustee to be, and shall be construed as, covenants running with the Mortgaged Property. As used herein, "Grantor" shall refer to the party named in the first paragraph of this Deed of Trust and to any subsequent owner of all or any portion of the Mortgaged Property. All Persons who may have or acquire an interest in the Mortgaged Property shall be deemed to have notice of, and be bound by, the terms of the Power

The contents of this document are subject to restrictions on disclosure as set forth herein.

Purchase Agreement and the other Power Purchase Agreement; however, no such party shall be entitled to any rights thereunder without the prior written consent of Beneficiary.

Section 9.3. Attorney-in-Fact. Grantor hereby irrevocably appoints Beneficiary and its successors and assigns, as its attorney-in-fact, which agency is coupled with an interest and with full power of substitution, solely for the following, limited purposes: (a) to execute and/or record any notices of completion, cessation of labor or any other notices that Beneficiary reasonably deems necessary to protect Beneficiary's interest, if Grantor shall fail to do so within ten (10) Business Days after written request by Beneficiary, (b) upon the issuance of a deed pursuant to the foreclosure of this Deed of Trust or the delivery of a deed in lieu of foreclosure, to execute all instruments of assignment, conveyance or further assurance with respect to the Leases, Rents, Proceeds, Insurance and Condemnation Awards in favor of the grantee of any such deed and as may be necessary or desirable for such purpose, (c) to prepare, execute and file or record financing statements, continuation statements, applications for registration and like papers necessary to create, perfect or preserve Beneficiary's security interests and rights in or to any of the Mortgaged Property, and (d) if any Event of Default has occurred and is continuing, to perform any obligation of Grantor hereunder, however: (1) Beneficiary shall not under any circumstances be obligated to perform any obligation of Grantor; (2) any sums advanced by Beneficiary in such performance shall be added to and included in the Obligations and shall bear interest at a rate which is equal to the Simple Interest Rate; (3) Beneficiary as such attorney-in-fact shall only be accountable for such funds as are actually received by Beneficiary; and (4) Beneficiary shall not be liable to Grantor or any other person or entity for any failure to take any action which it is empowered to take under this Section 9.3.

Section 9.4. Successors and Assigns. This Deed of Trust shall be binding upon and inure to the benefit of Beneficiary, Trustee and Grantor and their respective successors and assigns. Grantor shall not, without the prior written consent of Beneficiary, assign any rights, duties or obligations hereunder.

Section 9.5. No Waiver. Any failure by Beneficiary or Trustee to insist upon strict performance of any of the terms, provisions or conditions of the Power Purchase Agreement shall not be deemed to be a waiver of same, and Beneficiary or Trustee shall have the right at any time to insist upon strict performance of all of such terms, provisions and conditions.

Section 9.6. Power Purchase Agreement. If any conflict exists between this Deed of Trust and the Power Purchase Agreement, the Power Purchase Agreement shall govern.

Section 9.7. Release or Reconveyance. Upon performance in full of the Obligations, or as otherwise required under the Power Purchase Agreement, and as otherwise required by the Power Purchase Agreement, Beneficiary, at Grantor's expense, shall release the Liens and security interests created by this Deed of Trust or reconvey the Mortgaged Property to the Person or Persons legally entitled thereto.

Section 9.8. Waiver of Stay, Moratorium and Similar Rights. Grantor agrees, to the full extent that it may lawfully do so, that it will not at any time insist upon or plead or in any way take advantage of any stay, marshalling of assets, extension, redemption or moratorium law

The contents of this document are subject to restrictions on disclosure as set forth herein.

now or hereafter in force and effect so as to prevent or hinder the enforcement of the provisions of this Deed of Trust or the Obligations secured hereby, or any agreement between Grantor and Beneficiary or any rights or remedies of Beneficiary or Trustee. Grantor waives, to the full extent permitted by law, (1) the benefit of all laws now existing or that may hereafter be enacted providing for any appraisal before sale of any portion of the Mortgaged Property; (2) all rights of redemption, valuation, appraisal, stay of execution, notice of election to mature or declare due the Obligations and the right to require marshaling in the event of foreclosure of the Liens hereby created; and (3) all rights and remedies that Grantor may have or be able to assert by reason of the laws of the State of California pertaining to the rights and remedies of sureties, including, without limitation, Sections 2809, 2810, 2819, 2839, 2845, 2849, 2850, 2899 and 3433 of the California Civil Code.

Section 9.9. Applicable Law. The provisions of this Deed of Trust regarding the creation, perfection and enforcement of the Liens and security interests herein granted shall be governed by and construed under the laws of the state in which the Mortgaged Property is located. All other provisions of this Deed of Trust shall be governed by the laws of the State of California, without regard to conflicts of laws principles. Grantor agrees that (i) whether or not deficiency judgments are available under the laws of the State of California after a foreclosure (judicial or nonjudicial) of the Mortgaged Property, or any portion thereof, or any other realization thereon by Beneficiary or Trustee, Beneficiary and Trustee shall have the right to seek such a deficiency judgment against Grantor in other states or foreign jurisdictions; (ii) to the extent Beneficiary or Trustee obtain a deficiency judgment in any other state or foreign jurisdiction then such party shall have the right to enforce such judgment in the State of California, as well as in other states or foreign jurisdictions; (iii) without limiting the generality of the foregoing, Grantor hereby waives, to the maximum extent permitted by law, any rights it may have under the California Code of Civil Procedure Sections 580b, 580d and 726 with respect to the Mortgaged Property and the enforcement or realization by Beneficiary or Trustee of their respective rights and remedies under this Deed of Trust or with respect to the Mortgaged Property; and (iv) the institution of any proceedings before an arbitrator or referee, the award or determination or ruling of such arbitrator or referee, and the seeking by Beneficiary or Trustee, or the actual issuance of, any injunction, declaratory relief, temporary restraining order or similar remedies in the State of California with respect to the Mortgaged Property, the Power Purchase Agreement or this Deed of Trust shall be considered a "judgment" for the purposes of such Section 580d or an "action" for the purposes of such Section 726.

Section 9.10. Headings. The Article, Section and Subsection titles hereof are inserted for convenience of reference only and shall in no way alter, modify or define, or be used in construing, the text of such Articles, Sections or Subsections.

Section 9.11. Entire Agreement. This Deed of Trust and the Power Purchase Agreement embody the entire agreement and understanding between Grantor and Beneficiary and supersede all prior agreements and understandings between such parties relating to the subject matter hereof and thereof. Accordingly, this Deed of Trust and the other Power Purchase Agreement may not be contradicted by evidence of prior, contemporaneous or subsequent oral agreements of the parties. There are no unwritten oral agreements between the parties.

The contents of this document are subject to restrictions on disclosure as set forth herein.

Section 9.12. Severability. This If any provision of this Deed of Trust is or becomes invalid, illegal or unenforceable, such provision shall be deemed amended to conform to applicable laws so as to be valid and enforceable or, if it cannot be so amended without materially altering the intention of the parties, it shall be stricken and the remainder of this Deed of Trust shall remain in full force and effect.

[The remainder of this page has been intentionally left blank]

IN WITNESS WHEREOF, Grantor has on the date set forth in the acknowledgement hereto, effective as of the date first above written, caused this instrument to be duly EXECUTED AND DELIVERED by authority duly given.

GRANTOR:

_____ a _____ limited liability company

By: _____
Name: _____
Title: _____

By: _____
Name: _____
Title: _____

State of CALIFORNIA)
) ss.
County of _____)

On _____, 20__, before me, _____,
personally appeared _____, personally known to me
(or proved to me on the basis of satisfactory evidence) to be the person(s) whose name(s) is/are
subscribed to the within instrument and acknowledged to me that he/she/they executed the same
in his/her/their authorized capacities, and that by his/her/their signatures on the instrument the
person(s) or the entity upon behalf of which the person(s) acted, executed the instrument.

WITNESS my hand and official seal.

My Commission expires:

Notary Public

[SEAL]

EXHIBIT A

Legal Description

**** End of EXHIBIT T****

The contents of this document are subject to restrictions on disclosure as set forth herein.

EXHIBIT U

Form of Intercreditor and Subordination Agreement

The contents of this document are subject to restrictions on disclosure as set forth herein.

EXHIBIT U

Form of Intercreditor and Subordination Agreement

RECORDING REQUESTED BY AND
WHEN RECORDED MAIL TO:

SPACE ABOVE THIS LINE RESERVED FOR
RECORDER'S USE

INTERCREDITOR AND SUBORDINATION AGREEMENT
BY AND BETWEEN

_____,
AS SENIOR AGENT
AND

SOUTHERN CALIFORNIA EDISON,
A CALIFORNIA CORPORATION,
AS OFFTAKER

[NOTE: THIS FORM TO BE USED FOR ANY LENDER TO WHOM SCE IS
REQUIRED TO PROVIDE A SUBORDINATION AGREEMENT UNDER THE
TERMS OF THE POWER PURCHASE AGREEMENT, TOGETHER WITH SUCH
CHANGES REASONABLY REQUESTED BY SUCH LENDER AND REASONABLY
APPROVED BY SCE]

The contents of this document are subject to restrictions on disclosure as set forth herein.

FORM OF

INTERCREDITOR AND SUBORDINATION AGREEMENT

This **INTERCREDITOR AND SUBORDINATION AGREEMENT** is made as of [] (as amended, restated or otherwise modified from time to time, this "Agreement"), by and between [] (together with its successors and assigns thereto, the "Senior Agent"), and SOUTHERN CALIFORNIA EDISON, a California corporation (together with its permitted successors and assigns, the "Offtaker").

A. [SPE], a Delaware limited liability company (the "Borrower") owns and is developing and constructing and will operate and use a wind generation facility located in _____ County, California (the "Project").

B. The Borrower has entered into (i) the [Loan Agreement] dated as of _____ (as amended, restated, supplemented, replaced or otherwise modified from time to time in accordance with the terms hereof, the "Senior Credit Agreement") with Senior Agent for the benefit of the lenders who are from time to time parties to the Senior Credit Agreement (together with their successors and assigns, collectively, the "Senior Lenders"), pursuant to which the Senior Lenders have agreed to provide certain loans (the "Senior Loan") to the Borrower in connection with the development, construction, ownership, operation and use of the Project, (ii) the Senior Security Agreement, dated as of _____ (as amended, restated, supplemented, replaced or otherwise modified from time to time in accordance with the terms hereof, the "Senior Security Agreement") with the Senior Agent, pursuant to which the Borrower has granted to the Senior Agent for the benefit of itself and the Senior Lenders a lien on and a first priority security interest in all of the Borrower's personal property, (such collateral referred to herein as the "Senior Security Agreement Collateral"), and (iii) the Leasehold Deed of Trust, Mortgage Assignment of Rents and Leases, Security Agreement and Fixture Filing dated as of _____ (as amended, restated, supplemented, replaced or otherwise modified from time to time in accordance with the terms hereof, the "Senior Deed of Trust") with the Senior Agent and the trustee specified therein, pursuant to which the Borrower has granted to the Senior Agent for the benefit of itself and the Senior Lenders a first priority lien on the Borrower's real property on which the Project is located, more particularly described on the attached Annex A thereto, and a security interest in all of the Borrower's assets and properties constituting the "Collateral" or "Trust Property" as such term is defined in the Senior Deed of Trust (such collateral referred to herein as the "Senior Deed of Trust Collateral"). In addition, Seller Parent (as hereinafter defined) has entered into the Senior Pledge and Security Agreement, dated as of _____ (as amended, restated, supplemented, replaced or otherwise modified from time to time in accordance with the terms hereof, the "Senior Pledge Agreement") with Senior Agent, pursuant to which pledgor has pledged to Senior Agent for the benefit of itself and the Senior Lenders certain of the membership interests in Borrower (such collateral referred to herein as the "Senior Pledge Agreement Collateral"). The Senior Deed of Trust, the Senior Security Agreement, the Senior Pledge Agreement and collectively with each other guaranty, security agreement, pledge agreement, mortgage, deed of trust or other collateral agreement now or hereafter entered into in

The contents of this document are subject to restrictions on disclosure as set forth herein.

connection with the Senior Obligations (as defined below), as the same may be amended, restated, supplemented, replaced or otherwise modified from time to time in accordance with the terms hereof are referred to herein, collectively, as the "Senior Security Documents". The Senior Security Agreement Collateral, the Senior Deed of Trust Collateral and the Senior Pledge Agreement Collateral and any other collateral under the Senior Security Documents or any other Senior Credit Documents or otherwise securing the Senior Loan granted by the Borrower or the Seller Parent in favor of the Senior Agent is referred to herein, collectively, as the "Senior Collateral". Notwithstanding the foregoing, the Senior Collateral does not include any Performance Assurance.

C. The Borrower has also entered into (i) the Generating Facility Power Purchase and Sale Agreement dated _____ (as amended, restated, supplemented, replaced or otherwise modified from time to time) (the "Power Purchase Agreement") with the Offtaker, pursuant to which the Borrower has agreed, among other things, to sell electrical energy generated at the Project to the Offtaker and to pay to the Offtaker certain damages in the event of a breach of Borrower's obligations thereunder, (ii) the Security Agreement dated as of _____ (as amended, restated, supplemented, replaced or otherwise modified from time to time, the "Subordinated Security Agreement") with the Offtaker, and (iii) the Leasehold Deed of Trust, Security Agreement, Assignment of Rents and Leases, and Fixture Filing dated as of _____ (as amended, restated, supplemented, replaced or otherwise modified from time to time, the "Subordinated Deed of Trust"). The Subordinated Security Agreement and the Subordinated Deed of Trust are referred to herein, collectively, as the "Subordinated Security Documents". All collateral under the Subordinated Security Documents granted by the Borrower to the Offtaker is hereinafter collectively referred to as the "Subordinated Collateral".

D. The Senior Agent and the Offtaker wish to enter into this Agreement in order to, among other things, (a) confirm that the Senior Agent's security interest in the Senior Collateral has priority over the Offtaker's security interest in the Senior Collateral, (b) provide for the relative rights of the Senior Agent and the Senior Lenders, on the one hand, and the Offtaker, on the other hand, in connection with the enforcement of their security interests in the Senior Collateral, and (c) confirm the Senior Agent's prior right to exercise Remedial Actions with respect to the Senior Collateral.

NOW, THEREFORE, in consideration of the foregoing and the mutual covenants herein contained, and for other good and valuable consideration, each of the Senior Agent (on behalf of and for the benefit of itself and the Senior Lenders) and the Offtaker hereby agrees as follows:

ARTICLE I DEFINITIONS

Section 1.1 Certain Definitions. The following terms when used in this Agreement shall have the following meanings:

"Agreement" is defined in the preamble hereto.

The contents of this document are subject to restrictions on disclosure as set forth herein.

“Applicable Law” means any law of the United States or any other jurisdiction where any Senior Collateral is located or the Borrower operates, including, without limitation, the UCC.

“Bankruptcy Code” means Title 11 of the United States Bankruptcy Code (11 U.S.C. 101 et seq.), as amended from time to time and any successor statute.

“Borrower” is defined in the Recital A hereto.

“Credit Documents” collectively means the Senior Credit Documents and the Subordinated Documents.

“Insolvency Proceeding” means (a) any voluntary or involuntary insolvency or bankruptcy case or proceeding, or any receivership, liquidation, reorganization or other similar case or proceeding relative to the Borrower, any other Obligor or any of their property or assets, or (b) any liquidation, dissolution, reorganization or winding up of the Borrower or any other Obligor, whether voluntary or involuntary and whether or not involving insolvency or bankruptcy, or (c) any assignment for the benefit of creditors or any other marshaling of assets and liabilities of the Borrower or any other Obligor.

“Intercreditor Party” means each party to this Agreement, together with such party’s successors and permitted assigns.

“Lien” means, with respect to any property or asset, any mortgage, lien, pledge, charge, deposit arrangement, security interest or encumbrance of any kind in respect of such property or asset, or any filing or recording of any instrument or document whatsoever that has the practical effect of creating a security interest in property.

“Obligor” means Borrower and the Seller Parent in its capacity as pledgor under the Senior Pledge Agreement.

“Offset Rights” means all rights of Offtaker under the Power Purchase Agreement or Applicable Law to setoff, reduce, withhold, offset, credit, or deduct against or from any amounts due, owing or payable under the Power Purchase Agreement to or for the account of Borrower.

“Offtaker” is defined in the preamble hereto.

“Performance Assurance” means the cash collateral, deposits, guaranties and cash equivalent (including letters of credit) portion of the Performance Assurance required under the Power Purchase Agreement.

“Power Purchase Agreement” is defined in the Recital C hereto.

“Proceeds” means “proceeds,” as such term is defined in Section 9-102 of the UCC and, in any event, shall include without limitation, (a) any and all proceeds of any insurance, indemnity, warranty or guaranty payable to any Obligor from time to time with respect to any of the Senior Collateral, (b) any and all payments (in any form whatsoever) made or due and payable to any Obligor from time to time in connection with any requisition, confiscation,

The contents of this document are subject to restrictions on disclosure as set forth herein.

condemnation, seizure or forfeiture of all or any part of the Senior Collateral by any governmental authority, (c) any and all other amounts from time to time paid or payable under or in connection with any of the Senior Collateral on account of any Remedial Action and (d) the following types of property acquired with cash Proceeds: accounts, chattel paper, contracts, documents, general intangibles, equipment, investment property and inventory, as such terms are defined in the UCC.

“Project” is defined in the Recital A hereto.

“Remedial Action” means any claim, action or agreement to judicially or non-judicially foreclose upon, take possession of, sell, lease, dispose of, or realize upon any of the Senior Collateral, whether pursuant to the UCC or other Applicable Law, by foreclosure, by self-help, repossession, by appointment of a receiver or trustee, by judicial action or otherwise, or any exercise of any right or power of ownership (including all voting and consent rights) with respect to any Senior Collateral, or an assignment or deed-in-lieu of any of the foregoing, or the exercise of any other right or remedy under the Subordinated Security Documents with respect to the Senior Collateral. “Remedial Action,” however, shall not include (i) claims or actions (including actions seeking either or both legal and equitable remedies) to interpret or enforce the terms of the Power Purchase Agreement or any obligations of Borrower to Offtaker, other than the Subordinated Obligations and the Subordinated Documents, or (ii) actions (including declaratory actions) to interpret or obtain a declaration of rights and duties with respect to the provisions of the Power Purchase Agreement relating to the Termination Payment (as defined therein); provided that Remedial Action shall include the enforcement of any Lien against the Senior Collateral by the Offtaker, or (iii) claims or actions against, or to realize upon, any Performance Assurance (including as a result of a failure by Borrower to pay a Subordinated Obligation).

“Security Documents” collectively means the Senior Security Documents and the Subordinated Security Documents.

“Seller Parent” means _____, a Delaware limited liability company.¹

“Senior Agent” is defined in the preamble hereto.

“Senior Collateral” is defined in the Recital B hereto.

“Senior Credit Agreement” is defined in the Recital B hereto.

“Senior Credit Documents” collectively means the Senior Credit Agreement, the Senior Security Agreement, the Senior Deed of Trust, any other Senior Security Documents and all other documents, instruments, guaranties and agreements now or hereafter executed or delivered in connection therewith, as the same may be amended, restated, supplemented, replaced or otherwise modified from time to time.

¹ Seller Parent may not be Alta Windpower Development, LLC, a Delaware limited liability company, or any successor as “Developer” under the Master Agreement (as defined in the Power Purchase Agreement).

The contents of this document are subject to restrictions on disclosure as set forth herein.

“Senior Lenders” is defined in the Recital B hereto.

“Senior Obligations” means (a) the principal of, and premium, if any, payable on redemption or prepayment of, and interest on, all indebtedness now existing or hereafter incurred, and all other now existing or hereafter incurred obligations, liability and indebtedness of every kind, nature and description of each Obligor under the Senior Credit Documents, contingent or not, due or not, direct or indirect, primary or secondary, liquidated or unliquidated, secured or unsecured, or otherwise from operation of law or otherwise, including without limitation, all fees, expenses (including reasonable fees and expenses of counsel), claims, charges, fees, indemnity obligations and interest (in each case whether arising, accruing or incurred before or after the commencement of any Insolvency Proceeding, and whether or not allowed in such Insolvency Proceeding), and (b) any renewals, extensions, modifications, amendments, replacements, supplements, deferrals or other changes to any of the foregoing, including the proceeds of any indebtedness used to refinance any of the foregoing (subject in the case of any such refinancings to the proviso in Section 3.2(a)(i)) and debtor in possession financing. To the extent any payment with respect to the Senior Obligations (as Proceeds of security, enforcement of any right of setoff or otherwise) is declared to be fraudulent or preferential, set aside or required to be paid to a trustee, receiver or similar person for any reason, then such payment or part thereof originally intended to be satisfied shall be deemed to be reinstated and outstanding as if such payment had not occurred. The term “Senior Obligations” does not include the Performance Assurance or any portion thereof.

“Senior Security Documents” is defined in the Recital B hereto.

“Subordinated Deed of Trust” is defined in Recital C. hereto.

“Subordinated Documents” collectively means the Subordinated Security Agreement, the Subordinated Deed of Trust and all other documents, instruments and agreements now or hereafter executed or delivered by Offtaker in connection therewith or the Senior Collateral, as the same may be amended, restated, supplemented, replaced or otherwise modified from time to time in accordance with the terms, excluding, however, the Power Purchase Agreement, any document or agreement evidencing the Performance Assurance or creating or perfecting a security interest in or pledge of the Performance Assurance, or any other agreement between Offtaker and Obligor that does not relate to the creation of a lien against or security interest in the Senior Collateral.

“Subordinated Obligations” means the obligations and liabilities of the Borrower secured by or under the Subordinated Documents. The Subordinated Obligations do not include the Performance Assurance or any portion thereof.

“Subordinated Security Agreement” is defined in the Recital C hereto.

“Subordinated Security Documents” is defined in the Recital C hereto, provided, however, that notwithstanding anything to the contrary in this Agreement, the Power Purchase Agreement or in any Subordinated Security Document, the term “Subordinated Security

The contents of this document are subject to restrictions on disclosure as set forth herein.

Documents” shall not include any document, agreement or instrument creating or perfecting a security interest in, or pledge of, the Performance Assurance or any portion thereof.

“UCC” means the Uniform Commercial Code as in effect in each applicable jurisdiction.

ARTICLE II COLLATERAL ISSUES, ETC.

Section 2.1 Representations and Warranties as to this Agreement. Each Intercreditor Party hereby represents and warrants for itself to the other Intercreditor Parties hereto that (a) it has all requisite power and authority to execute, deliver and perform under this Agreement; (b) the execution, delivery and performance by it of this Agreement has been duly authorized by all requisite corporate or other action; (c) no consent or approval of any other person and no consent, license, approval or authorization of any governmental authority is required in connection with the execution, delivery and performance by it of this Agreement; and (d) this Agreement constitutes its legal, valid and binding obligation enforceable in accordance with its terms subject to applicable bankruptcy, insolvency, reorganization, moratorium or other similar laws in effect from time to time affecting the rights of creditors generally and general principles of equity regardless of whether such enforcement is considered in a proceeding in equity or at law.

Section 2.2 Priority of Liens. Irrespective of (a) the time, order, manner or method of creation, attachment, perfection or validity of the respective Liens granted by the Borrower or any other Obligor to any Intercreditor Party in any or all of the Senior Collateral, (b) the time, manner or place of the filing of the respective UCC financing statements, deeds of trust, or other applicable filings of any Intercreditor Party with respect to any or all of the Senior Collateral or other means of perfection, (c) any provision or statement contained in any Credit Document, (d) any other event, circumstance, occurrence or otherwise or (e) any provision of any Applicable Law to the contrary, the Liens granted by the Borrower or any other Obligor to the Senior Agent (for and on behalf of itself and the Senior Lenders), or otherwise held by the Senior Agent or Senior Lenders, in and to the Senior Collateral, and all terms, covenants, rights and remedies of Senior Agent and the Senior Lenders under the Senior Credit Documents with respect to the Senior Collateral, are and shall be unconditionally superior and prior in all respects to any Liens granted by the Borrower or any other Obligor therein to the Offtaker and to all terms, covenants, rights and remedies of Offtaker under the Subordinated Security Documents with respect to the Senior Collateral, unless and until the Senior Obligations shall have been indefeasibly paid in full and the Senior Security Documents shall have been finally released and discharged. The Offtaker acknowledges and agrees that the Senior Agent shall have sole and exclusive control, dominion and discretion over all of the Borrower’s deposit accounts, securities accounts and other similar bank or investment accounts, all certificates evidencing ownership interests in the Borrower and all amounts and investment property on deposit from time to time therein or credited from time to time thereto other than the Performance Assurance. Except as otherwise provided in this Agreement, while the Senior Obligations remain outstanding the Offtaker shall not hinder, delay, interfere, contest or take any other action that may, either directly or indirectly, limit in any respect the Senior Agent’s security interest in and to the Senior Collateral. The expression “payment in full” or “paid in full” or any similar term or phrase when

The contents of this document are subject to restrictions on disclosure as set forth herein.

used in this Agreement shall mean the termination of all commitments under the Senior Credit Documents and final and indefeasible payment in full of all Senior Obligations in cash, or, in the case of Senior Obligations consisting of contingent obligations in respect of letters of credit or other reimbursement obligations for drawings under letters of credit under the Senior Credit Documents, the setting apart of cash sufficient to discharge such portion of Senior Obligations in an account for the exclusive benefit of the Senior Agent, in which account the Senior Agent shall be granted a first priority perfected security interest in a manner acceptable to the Senior Agent, which payment or perfected security interest shall have been retained by the Senior Agent, in each case, for the period that such payment or security interest may be avoided as a preference under the Bankruptcy Law or other Applicable Law.

Section 2.3 Limitation on Rights of the Offtaker. Notwithstanding anything to the contrary set forth in the Subordinated Security Documents, unless and until the Senior Obligations shall have been indefeasibly paid in full and the Senior Security Documents shall have been finally released and discharged, neither the Offtaker nor any agent or representative therefor shall (i) have the right to commence or take, and the Offtaker shall not commence or take or cause or permit any agent or representative to directly or indirectly commence or take, any Remedial Action with respect to the Senior Collateral, (ii) commence, prosecute or participate in any administrative, legal or equitable action or proceeding against any Obligor or their respective properties seeking the filing of any reorganization, arrangement, composition, readjustment, liquidation, bankruptcy or any other action involving the readjustment of all or any part of the Senior Obligations or Subordinated Obligations, or other similar relief under the Bankruptcy Code or any present or future state or foreign statute, law or regulations relative to any Obligor or its properties or any proceedings for voluntary liquidation, dissolution or other winding up of any Obligors' business, or the appointment of any trustee, receiver or liquidator for any Obligor or any part of its properties or any assignment for the benefit of creditors or any marshaling of assets of any Obligor, (iii) commence, prosecute or participate in any administrative, legal or equitable action or proceeding challenging the enforceability or exercise of the Senior Credit Documents, including the rights and remedies afforded to the Senior Agent in the Senior Collateral, or (iv) take any other action against the Senior Collateral under the Subordinated Security Documents. Subject to the foregoing and the other terms, conditions and limitations of this Agreement (a) the Offtaker may exercise its rights and remedies under the Power Purchase Agreement, (b) nothing in this Agreement otherwise modifies, impairs or shall be deemed a waiver of any rights or remedies the Offtaker may have with respect to the Subordinated Obligations, (c) nothing contained in this Agreement shall limit or affect the Offtaker's rights and remedies with respect to the Performance Assurance, and (d) the Offtaker shall not have any duties, obligations or liabilities to the Senior Agent or the Senior Lenders, except as expressly provided herein.

Section 2.4 Enforcement Rights of Senior Lenders. The Senior Agent and each Senior Lender shall have the exclusive right to carry out, or not to carry out, the provisions of each Senior Security Document and other Senior Credit Documents, and to exercise or not to exercise any Remedial Action and other rights and remedies under the Senior Credit Documents, all in the Senior Agent's and each Senior Lender's sole discretion and in the exercise of its and their sole business judgment (without regard to the rights of the Offtaker under any Subordinated

The contents of this document are subject to restrictions on disclosure as set forth herein.

Document). Such exclusive rights shall include, specifically (but not by way of limitation) the right to hold, prepare for sale, sell, lease or otherwise dispose of (or not take any such action), any or all of the Senior Collateral and to incur reasonable expenses in connection therewith, all as may be desirable in the Senior Agent's and each Senior Lender's sole discretion. In exercising its rights as aforesaid, the Senior Agent and each Senior Lender shall not have any duties, obligations or liabilities to the Offtaker. Nothing in this Agreement modifies, impairs or shall be deemed a waiver of any rights or remedies the Senior Agent or the Senior Lenders may have with respect to the Senior Collateral or under the Senior Credit Documents.

Section 2.5 PPA Payments. Each Intercreditor Party acknowledges that Offtaker's right to collect, receive and retain any payments from Borrower or any other Obligor under or in respect of the Power Purchase Agreement, including without limitation, Annual Warranty Availability Lost Production Payment, Energy Replacement Damage Amount, the Performance Assurance and any other amounts payable thereunder, or to enforce any of the terms thereof, other than the Termination Payment, (collectively, the "PPA Payments") are not affected by this Agreement in any manner except that the right to enforce the Subordinated Obligations (including the Termination Payment) and the Subordinated Documents shall be subject to the terms of this Agreement.

Section 2.6 Offset Rights. Notwithstanding anything to the contrary contained in this Agreement, Offtaker may at any time permitted under the Power Purchase Agreement or Applicable Law exercise any or all of its Offset Rights (including as a result of a failure by Borrower to pay any portion of the Subordinated Obligations) and retain, for its sole account and not subject to any Lien in favor of Senior Agent or Senior Lenders, any and all funds or proceeds received, retained or held as a result of or in connection with its exercise of its Offset Rights.

Section 2.7 Performance Assurance. Notwithstanding anything to the contrary contained in this Agreement, Offtaker may at any time permitted under the Power Purchase Agreement or Applicable Law exercise any or all of its rights against the Performance Assurance or any portion thereof (including as a result of a failure by Borrower to pay any portion of the Subordinated Obligations), and retain, for its sole account and not subject to any Lien in favor of Senior Agent or Senior Lenders, any and all funds or proceeds received, retained or held as a result of or in connection with its exercise of its rights against the Performance Assurance or any portion thereof.

Section 2.8 Application of Agreement upon taking possession of Facility. Notwithstanding anything to the contrary contained in this Agreement, nothing in this Agreement shall be deemed to amend, waive, diminish or modify the terms of the Power Purchase Agreement.

ARTICLE III OTHER AGREEMENTS

Section 3.1 Insurance and Condemnation Awards. (a) The Senior Agent and the Senior Lenders shall have the sole and exclusive right, subject to the rights of the Borrower under the Senior Credit Documents, to adjust, settle, direct or otherwise deal with any insurance

The contents of this document are subject to restrictions on disclosure as set forth herein.

policy or proceeds therefrom covering or relating to the Senior Collateral and to approve any award granted in any condemnation or similar proceeding affecting the Senior Collateral.

(b) All the proceeds of any insurance policies and any awards relating to the Senior Collateral shall be paid exclusively to the Senior Agent and applied as provided in the Senior Credit Documents.

(c) In the event that the Senior Agent or the Senior Lenders allow any portion of such insurance proceeds or awards with respect to the Senior Collateral to be used by the Borrower or another applicable Obligor to repair or replace the Senior Collateral affected or for any other purposes, the Offtaker agrees to take all reasonable actions to permit such use and shall not interfere therewith or claim any interest therein.

Section 3.2 No Obligation Owing to Offtaker. (a) The Senior Agent and the Senior Lenders may, at any time, without the consent of, or notice to, the Offtaker, without incurring any liabilities to the Offtaker and without impairing or releasing any of their Liens in the Senior Collateral and other benefits provided in this Agreement and the other Senior Credit Documents, do any one or more of the following:

(i) change in any manner the Senior Obligations and the Senior Credit Documents, including the manner, place or terms of payment or change or extend the time of payment of, or renew, refinance, exchange, substitute, amend, settle, compromise, increase [by up to ___% of the original principal amount of the Senior Obligations] or alter, the terms of any of the Senior Obligations or any Lien in any of the Senior Collateral, or any liability incurred, directly or indirectly in respect thereof (including, without limitation, any increase [by up to ___% of the original principal amount of the Senior Obligations] in or extension or refinancing of the Senior Obligations, without any restriction as to the tenor or terms of any such increase, extension or refinancing;

(ii) sell, exchange, substitute, release, surrender, realize upon, enforce or otherwise deal with in any manner and in any order any part of the Senior Collateral, or any Obligor or Senior Obligation, or any liability incurred directly or indirectly in respect thereof; and

(iii) exercise or delay in or refrain from exercising any right or remedy against all or any part of the Senior Collateral, any Obligor or with respect to any Senior Credit Document or Senior Obligation.

(b) The Senior Agent and the Senior Lenders shall have no obligation whatsoever, to the Offtaker to assure the ownership, existence or genuineness of the Senior Collateral, and the Senior Agent and the Senior Lenders shall have no obligation whatsoever to the Offtaker to preserve the rights or benefits of any person (including the Offtaker) in the Senior Collateral.

(c) Neither the Senior Agent nor the Senior Lenders shall be under any obligation to the Offtaker to institute or defend any action, suit or other proceeding, or take any

The contents of this document are subject to restrictions on disclosure as set forth herein.

other action against any person, in connection with any Senior Collateral. Each Intercreditor Party shall be entitled to rely upon any writing or other document believed by such Intercreditor Party to be genuine and correct and to have been signed, sent or made by the proper person. Each Intercreditor Party may consult counsel with respect to any question arising hereunder or in connection herewith and such Intercreditor Party shall not be liable for any action taken or omitted to be taken in good faith upon advice of such counsel.

(d) All rights, interests, agreements and obligations of the Senior Agent and Senior Lenders under this Agreement shall remain in full force and effect irrespective of:

(i) any lack of validity or enforceability of the Senior Credit Documents or any agreement or instrument relating thereto;

(ii) any taking, exchange, release or non-perfection of any collateral, or any taking, release or amendment or waiver of or consent to or departure from any guaranty or indemnity for all or any portion of the Senior Loan;

(iii) any manner of application of collateral, or proceeds thereof, to all or any portion of the Senior Loan, or any manner of sale or other disposition of any collateral for all or any portion of the Senior Loan or any other assets of any Obligor;

(iv) any change, restructuring or termination of the corporate structure or existence of any Obligor; or

(v) any other circumstance which might otherwise constitute a defense available to, or a discharge of any Obligor in respect of the Senior Loan in respect of this Agreement.

Section 3.3 *Insolvency Proceedings.* In connection with any Insolvency Proceeding, the Senior Agent and the Senior Lenders, on the one hand, and the Offtaker, with respect to the Subordinated Obligations and the Subordinated Documents, on the other hand, agree as follows:

3.3.1 Filing of Claims. The Offtaker may file proofs of claim and other pleadings and motions with respect to the Senior Collateral, subject to the limitations contained in this Agreement. Offtaker shall not make or consent to any filing or motion, or vote or take any other action, including without limitation, voting in favor of any plan of reorganization, which would have the effect of (a) modifying or abrogating any of the rights or interests of the Senior Agent or Senior Lenders under this Agreement, or (b) adversely affecting Senior Agent or Senior Lenders' rights or remedies under the Senior Credit Documents.

3.3.2 Automatic Stay. The Offtaker shall not seek relief from the automatic or any other stay in any Insolvency Proceeding in connection with the enforcement of any of its rights and remedies under any of the

The contents of this document are subject to restrictions on disclosure as set forth herein.

Subordinated Security Agreements or otherwise with respect to the Senior Collateral, excluding its rights and remedies with respect to the Performance Assurance and/or its Offset Rights; provided, however, that in the event that failure to take such action with respect to any Senior Collateral by the Offtaker would cause the loss of any of its rights under any Subordinated Documents, the Offtaker may take such action to preserve such right so long as the exercise of such right is not commenced until after this Agreement is terminated.

3.3.3 Distributions.

(a) In the event of any distribution, division, or application, partial or complete, voluntary or involuntary, by operation of law or otherwise, of all or any part of the assets of any Obligor or the proceeds thereof to the creditors of any Obligor or readjustment of the obligations and indebtedness of any Obligor, whether by reason of liquidation, bankruptcy, arrangement, receivership, assignment for the benefit of creditors, marshaling of assets of one or more of the Obligors or any other action or proceeding involving the readjustment of all or any part of the Senior Loan or Subordinated Obligations or the application of the assets of any of the Obligors to the payment or liquidation thereof, or upon the dissolution or other winding up of any Obligors' business, or upon the sale of all or substantially all of any Obligors' assets, then, and in any such event, (i) the Senior Lenders shall first receive payment in full of all Senior Obligations prior to the payment of all or any part of the Subordinated Obligations, (ii) any payment or distribution of any kind or character, whether in cash, property or securities, by set-off, counterclaim or otherwise, to which the Offtaker would be entitled with respect to the Subordinated Obligations but for the provisions of this Agreement, shall be paid or delivered by the liquidating trustee or agent or other person making such payment or distribution, whether a trustee in bankruptcy, a receiver or liquidating trustee or otherwise, directly to the Senior Agent, to the extent necessary to make payment in full of all Senior Obligations remaining unpaid after giving effect to any concurrent payment or distribution to the Senior Lenders, and (iii) in the event that, notwithstanding the foregoing provisions of this Agreement, Offtaker shall have received any payment or distribution of any kind or character, whether in cash, property or securities, by set-off, counterclaim or otherwise with respect to the Subordinated Obligations before all Senior Obligations are paid in full, then and in such event such payment or distribution shall be deemed to be the property of, segregated, received and held in trust for the benefit of and shall be forthwith paid over or delivered to the Senior Agent for application in the manner received to the payment of all Senior Obligations remaining unpaid until all such Senior Obligations shall have been paid in full.

(b) Other Restrictions. Until the full and final payment of the Senior Obligations, the Offtaker shall not seek to cause the Borrower to confirm or vote in favor of a plan of reorganization pursuant to Section 1129(b)(i) of the Bankruptcy Code that fails to provide for either the full and final payment of the Senior Obligations on account of the Senior Obligations on the effective date of such confirmed plan of reorganization. In addition, Offtaker shall not contest (or support any other entity contesting) (a) any request by Senior Agent for adequate protection pursuant to Section 361 of the Bankruptcy Code or otherwise, (b) any

The contents of this document are subject to restrictions on disclosure as set forth herein.

objection by Senior Agent or Senior Lenders to any motion, relief, action or proceeding based on the Senior Lenders claiming a lack of adequate protection pursuant to Section 361 of the Bankruptcy Code or otherwise, (c) the entry of any cash collateral order in favor of the Senior Lenders, (d) the entry of any financing order in favor of the Senior Lenders under Section 364 of the Bankruptcy Code or otherwise, (e) an election by the Senior Lenders pursuant to Section 1111(b) of the Bankruptcy Code, or (f) any claim submitted in any proceeding by Senior Agent or Senior Lenders, or any valuation of the Senior Collateral submitted by Senior Agent or Senior Lenders in such proceeding. Senior Agent shall give Offtaker such notice of the foregoing actions as may be required by the Bankruptcy Code. Notwithstanding anything to the contrary which may be contained herein, the Offtaker may file motions under Section 365 of the Bankruptcy Code to require the Borrower to assume or reject the Power Purchase Agreement.

(c) Reinstatement. The Senior Obligations shall continue to be treated as Senior Obligations and the provisions of this Agreement shall continue to govern the relative rights and priorities of the Senior Lenders and the Offtaker even if all or part of the Senior Obligations or the security interests securing the Senior Obligations are subordinated, set aside, avoided, declared to be fraudulent or preferential, or disallowed in connection with any Insolvency Proceeding. This Agreement shall be reinstated if at any time any payment of any of the Senior Obligations is rescinded or must otherwise be returned by any holder of Senior Obligations or any representative of such holder.

(d) The foregoing provisions of this Section shall not apply to exercise Offtaker's rights under Section 2.5, 2.6 or 2.7 except that such rights under Section 2.5 shall not be interpreted to allow enforcement of any Lien against the Senior Collateral by the Offtaker.

Section 3.4 Waivers. (a) No right of the Senior Agent or any Senior Lender to enforce the Lien subordination in any Senior Collateral or Remedial Action with respect thereto in respect of any Senior Collateral as provided in this Agreement shall in any manner be prejudiced or impaired by any act or failure to act on the part of the Borrower or any other Obligor or by any act or failure to act by the Senior Agent or any Senior Lender, or by any noncompliance by any person with the terms, provisions and covenants of any of the Senior Credit Documents or any of the Subordinated Documents, regardless of any knowledge thereof which the Senior Agent or any Senior Lender may have or be otherwise charged with.

(b) The Offtaker hereby waives, to the fullest extent permitted by law, any claim it may have against the Senior Agent or any Senior Lender arising out of or with respect to any action which the Senior Agent or any Senior Lender may take or permit or omit to take with respect to: (i) the Senior Credit Documents, (ii) collection of the Senior Obligations, (iii) any Obligor, (iv) the Senior Collateral, (v) any Remedial Action or the enforcement of any right or remedy under the Senior Credit Documents, or (vi) as a result of any other actions otherwise permitted pursuant to this Agreement (including, without limitation, Section 2.4) not including any claims arising out of Senior Agent's or Senior Lenders' gross negligence or willful misconduct. The Offtaker agrees that the Senior Agent and the Senior Lenders have no duty to it in respect of the maintenance or preservation of the Senior Collateral or any rights of any person therein or in respect of the application of any proceeds of the Senior Loan. The Senior Agent and the Senior Lenders agree that, except as set forth in this Agreement, the Offtaker shall have

The contents of this document are subject to restrictions on disclosure as set forth herein.

no obligation owing to the Senior Agent and the Senior Lenders. Notwithstanding the foregoing, no action by the Senior Agent or the Senior Lenders pursuant to this Section 3.4(b) will have the effect of amending the Power Purchase Agreement without the express written agreement of the Offtaker.

(c) The Offtaker agrees not to assert and hereby waives, to the fullest extent permitted by law, any right to contest the validity, priority or enforceability of the Senior Security Documents, or to demand, request, plead or otherwise assert or otherwise claim the benefit of, any marshaling, appraisal, valuation or other similar right that may otherwise be available under Applicable Law with respect to the Subordinated Obligations or any other similar rights a junior secured creditor may have under Applicable Law with respect to the Subordinated Obligations.

(d) The Offtaker hereby waives any defense based on the adequacy of a remedy at law which might be asserted as a bar to the remedy of specific performance of this Agreement in any action brought therefor by the Senior Agent or any Senior Lender.

(e) Notwithstanding anything to the contrary in this Section 3.4, nothing in this Agreement shall constitute Offtaker's waiver of or agreement not to assert any or all of its Offset Rights or its rights to or against the Performance Assurance.

Section 3.5 Information Concerning the Borrower, etc. Each Intercreditor Party shall be responsible for keeping itself informed of (a) the financial condition of the Borrower, the other Obligor and all endorsers and/or guarantors of the Subordinated Obligations or the Senior Obligations, as the case may be, and (b) all other circumstances bearing upon the risk of nonpayment of the Subordinated Obligations or the Senior Obligations, as the case may be. No Intercreditor Party shall have any present or future duty or responsibility to any other Intercreditor Party to advise them of information known to it regarding the financial condition of Borrower or any other Obligor or of any circumstances bearing upon the risk of nonpayment of the Senior Obligations. If any such information is conveyed by any Intercreditor Party to any other Intercreditor Party for the accuracy or completeness of any such information, such Intercreditor Party shall have no continuing duty or responsibility to advise such other Intercreditor Party of any inaccuracy in such information that it subsequently discovers or of any updated or subsequent information, whether or not of like kind.

Section 3.6 No Rights of Subrogation. No payment or distribution to the Senior Agent or any Senior Lender shall entitle the Offtaker to exercise any right of subrogation until the Senior Obligations shall have been indefeasibly paid in full and the Senior Security Documents shall have been finally released and discharged.

Section 3.7 Application of Payments. All proceeds arising from any Remedial Action with respect to any Senior Collateral (whether or not resulting from or after an Insolvency Proceeding) shall be applied, first, to the payment of the Senior Obligations in the manner provided in the Senior Credit Documents until they have been indefeasibly paid in full in cash and second, to the extent required by Applicable Law, to the payment of the Subordinated Obligations until they are indefeasibly paid in full in cash.

The contents of this document are subject to restrictions on disclosure as set forth herein.

Section 3.8 Independent Decisions. Each Intercreditor Party has, independently and without reliance on any other Intercreditor Party, and instead in reliance upon information supplied to it on behalf of the Borrower and upon such other information as it has deemed appropriate, made its own independent decision to enter into its Credit Documents and to make the extensions of credit contemplated thereunder; and each Intercreditor Party shall, independently and without reliance upon any other Intercreditor Party, continue to make its own independent analysis and decisions in acting or not acting under its Credit Documents and this Agreement.

Section 3.9 Turnover of Prohibited Transfers. If any Senior Collateral is received by the Offtaker in violation of the terms of this Agreement, such Senior Collateral shall, without the necessity of demand or request by the Senior Agent, be delivered forthwith by the Offtaker to the Senior Agent for application to the Senior Obligations, in the form received, except for the addition of any endorsement or assignment necessary to effect a transfer of all rights therein to such other party. Until so delivered, any Senior Collateral shall be held by the Offtaker in trust for the Senior Agent and shall not be commingled with other funds or property of the Offtaker.

Section 3.10 Effectiveness During Insolvency Proceeding. This Agreement shall continue in full force and effect notwithstanding any Insolvency Proceeding, and shall apply with full force and effect with respect to all Senior Collateral acquired by the Borrower and each other Obligor, and to all Senior Obligations and Subordinated Obligations incurred by the Borrower and each other Obligor from and after the initiation of any such Insolvency Proceeding.

Section 3.11 Amendments. The Offtaker shall not amend, supplement or otherwise modify, without the consent of the Senior Agent, the terms of any of its Subordinated Documents, or enter into any other agreement having the effect of doing so, which, in each case, (i) is inconsistent in any respect with the terms of this Agreement, or (ii) that may reasonably be expected to be materially adverse to the ability of the Senior Agent or the Senior Lenders to enforce the Senior Credit Documents.

Section 3.12 Indulgences Not Waivers. Neither the failure nor any delay on the part of the Senior Agent or any Senior Lender to exercise any right, remedy, power or privilege hereunder or under any instruments, documents or agreements evidencing or relating to any of the Senior Obligations shall operate as a waiver thereof or give rise to an estoppel, nor be construed as an agreement to modify the terms of this Agreement, nor shall any single or partial exercise of any right, remedy, power or privilege with respect to any occurrence be construed as a waiver of such right, remedy, power or privilege with respect to any other occurrence. No consent or waiver by a party hereunder shall be effective unless it is in writing and signed by the party making such consent or waiver, and then only to the extent specifically stated in such writing.

Section 3.13 Duration and Termination; Payment Invalidated. (a) This Agreement shall constitute a continuing agreement and shall terminate with respect to the Senior Agent and the Senior Lenders only upon the final and indefeasible payment in full in cash of all of the Senior Obligations, the irrevocable termination of all commitments to make extensions of credit under the Senior Credit Documents and the final release and discharge of the Senior Security

The contents of this document are subject to restrictions on disclosure as set forth herein.

Documents. The agreements set forth herein shall remain in full force and effect regardless whether the Offtaker, the Senior Agent or any Senior Lender in the future seeks to rescind, amend, terminate or reform, by litigation or otherwise, its agreements with the Borrower. The termination of this Agreement shall, subject to clause (b), release fully and irrevocably all parties hereto from any and all liabilities (including, without limitation, the validity of this Agreement on an ongoing basis), duties and responsibilities hereunder to the same extent as if this Agreement had been fully terminated by all the parties hereto, provided that the foregoing shall not release any of the parties with respect to any obligations arising prior to such termination.

(b) In the event that this Agreement is terminated with respect to the Senior Agent and the Senior Lenders, as provided in clause (a), and the Senior Agent or any Senior Lender shall be required by a court or other tribunal of competent jurisdiction to disgorge, refund, rebate or otherwise return any amount received with respect to any of the Senior Collateral to any debtor-in-possession or trustee in respect of any Insolvency Proceeding or any other person (whether as the result of such payment constituting, or being alleged to constitute, a preference, a fraudulent conveyance or any other payment required to be disgorged pursuant to any such Insolvency Proceeding) then, in any such event, (i) the terms and conditions of this Agreement shall be reinstated, notwithstanding any prior termination of this Agreement pursuant to this Section, and (ii) all provisions of this Agreement shall once again be operative until all such Senior Obligations are again paid in full in cash.

Section 3.14 Credit Documents. The Offtaker confirms that it has delivered to the Senior Agent true and correct copies of its Subordinated Credit Documents, in each case as in effect on the date hereof, and all UCC financing statements and other filings to perfect its security interest in the Senior Collateral. The Senior Agent confirms that it has delivered to the Offtaker true and correct copies of the Senior Credit Documents, as in effect on the date hereof, and all UCC financing statements and other filings to perfect its security interest in the Senior Collateral.

Section 3.15 New Agreement. In connection with any assignment or transfer of any or all of the Senior Obligations (including any refinancing or replacement thereof or any debtor-in-possession financing provided to any Obligor by the Senior Lender), the Offtaker agrees, to execute and deliver an agreement containing terms identical to those contained herein in favor of any such assignee or transferee and, in addition, will execute and deliver an agreement containing terms identical to those contained herein in favor of any third person who succeeds to or replaces any or all of the financing provided under the Senior Credit Documents, whether such successor financing or replacement occurs by transfer, assignment, "takeout" or any other means or vehicle, in each circumstance to which this Section 3.15 applies, if and only to the extent, Offtaker would be required to execute a new or replacement Subordination Agreement for the benefit of such parties under the terms of the Power Purchase Agreement.

Section 3.16 Legends. Each of the Subordinated Documents shall be marked with a conspicuous legend indicating that such documents are subject to this Agreement.

Section 3.17 Notices. The Senior Agent will use good faith efforts to give the Offtaker copies of any notice of default given to the Borrower under the Senior Security Documents,

The contents of this document are subject to restrictions on disclosure as set forth herein.

provided that Senior Agent's failure to give such notice shall not constitute a breach or default of this Agreement or otherwise affect the rights and duties of either of the Intercreditor Parties under this Agreement or impose any liability on Senior Agent or Sender Lenders.

ARTICLE IV MISCELLANEOUS

Section 4.1 Conflict. In the event of any conflict between the terms of any of the Senior Credit Documents or the Subordinated Documents and the terms of this Agreement, the terms of this Agreement shall control.

Section 4.2 Benefit of Agreement, etc. This Agreement is entered into for the benefit of the parties hereto, and their respective successors and assigns, only and no benefit shall accrue or is intended with respect to any other third party, including, without limitation, the Borrower, any trustee in bankruptcy for the Borrower or any other Obligor. This Agreement is intended only to define the obligations of the Offtaker, on the one hand, and the Senior Agent and the Senior Lenders, on the other hand, in the Senior Collateral, and this Agreement shall in no way affect or impair the obligations of the Borrower or any other Obligor under the Senior Credit Documents or the Subordinated Documents.

Section 4.3 Amendment; No Waiver. This Agreement may be amended, modified or supplemented, but only by a written agreement signed by both parties hereto. Any waiver or consent shall be effective only in the specific instance and for the specified purpose for which given. A waiver or consent shall be effective only if it is in writing and signed by the party giving the waiver or consent

Section 4.4 Successors and Assigns. All the covenants, terms and agreements in this Agreement shall bind and inure to the benefit of the respective successors and assigns of the Borrower, the Offtaker and the Senior Agent. The Offtaker shall not assign all or any part of its rights and obligations under the Subordinated Documents to any person unless such person agrees in writing to be bound by all the terms of this Agreement. The Senior Agent shall not assign all or any part of its rights and obligations under the Senior Security Documents to any person unless such person agrees in writing to be bound by the terms of this Agreement.

Section 4.5 Severability. In the event any provision of this Agreement is determined to be void, unlawful, or otherwise unenforceable, that provision shall be severed from the Agreement, and the remainder of this Agreement shall be interpreted and constructed in such a manner as if a provision containing terms as nearly like the void, unlawful, or unenforceable provision as possible replaced such severed provision, and the Agreement, as so interpreted and constructed, shall continue to be in full force and effect. If the application of any provision of this Agreement to any Person or circumstance is determined to be void, unlawful, or unenforceable, then that provision remains valid, lawful, and enforceable as applied to other Persons and circumstances.

Section 4.6 Notices. All notices, requests, demands or other communications hereunder shall be in writing and shall be delivered personally or by reputable express courier

The contents of this document are subject to restrictions on disclosure as set forth herein.

service addressed to the relevant party hereto at the address stated below or at any other address notified by the party to the other as its address for purposes of this Agreement. Any communication so given personally and any notice so given by express courier service shall be deemed to have been delivered on the date of receipt of the intended recipient. As proof of such delivery it shall be sufficient to produce a receipt showing personal service or the receipt of a reputable courier company showing the correct address of the addressee.

If to the Senior Agent:

with a copy to:

If to the Offtaker:

Southern California Edison

with a copy to:

***Section 4.7 Governing Law; Consent to Jurisdiction.* THIS AGREEMENT SHALL BE CONSTRUED IN ACCORDANCE WITH AND GOVERNED BY THE LAWS OF THE STATE OF NEW YORK APPLICABLE TO CONTRACTS MADE AND TO BE PERFORMED IN SUCH STATE.**

***Section 4.8* EACH PARTY HERETO HEREBY IRREVOCABLY AND UNCONDITIONALLY SUBMITS FOR ITSELF AND ITS PROPERTY TO THE NON-**

The contents of this document are subject to restrictions on disclosure as set forth herein.

EXCLUSIVE JURISDICTION OF THE UNITED STATES DISTRICT COURT FOR THE SOUTHERN DISTRICT OF NEW YORK AND OF THE SUPREME COURT OF THE STATE OF NEW YORK SITTING IN THE COUNTY OF NEW YORK, AND ANY APPELLATE COURT FROM ANY OF THE FOREGOING COURTS FOR PURPOSES OF ALL LEGAL SUITS, ACTIONS, AND PROCEEDINGS ARISING OUT OF, CONNECTED WITH OR RELATING TO THIS AGREEMENT OR THE TRANSACTIONS CONTEMPLATED HEREBY. EACH PARTY HEREBY IRREVOCABLY WAIVES AND AGREES NOT TO PLEAD, TO THE EXTENT PERMITTED BY APPLICABLE LAW, ANY OBJECTION OR DEFENSE WHICH IT MAY NOW OR HEREAFTER HAVE TO (I) THE LAYING OF VENUE IN SUCH A COURT, (II) ANY CLAIM THAT SUCH A COURT IS AN INCONVENIENT FORUM, (III) LACK OF PERSONAL, IN REM OR QUASI IN REM JURISDICTION, OR (IV) ANY SIMILAR GROUNDS.

Section 4.9 Waiver of Jury Trial, etc. TO THE FULLEST EXTENT PERMITTED BY APPLICABLE LAW, EACH PARTY HERETO HEREBY WAIVES ANY RIGHT TO HAVE A JURY PARTICIPATE IN RESOLVING ANY ACTION, SUIT OR PROCEEDING, WHETHER ARISING IN CONTRACT, TORT OR OTHERWISE, ARISING OUT OF, CONNECTED WITH OR RELATING TO THIS AGREEMENT OR THE TRANSACTIONS CONTEMPLATED HEREBY.

Section 4.10 Counterparts; Electronic Delivery. This Agreement may be executed in one or more counterparts, each of which shall be an original but all of which, taken together, shall constitute only one legal instrument. It shall not be necessary in making proof of this Agreement to produce or account for more than one counterpart. The delivery of an executed counterpart of this Agreement by electronic means, including by facsimile or by “.pdf” attachment to email, shall be deemed to be valid delivery thereof.

Section 4.11 Further Assurances. The Offtaker, on the one hand, and the Senior Agent, on the other hand, agree to execute such further documents and agreements as may be reasonably requested by the other to give effect to the purposes of this Agreement.

Section 4.12 Reliance. The consent by the Senior Lenders to the execution and delivery of the Subordinated Documents and the grant to the Offtaker of a Lien in the Senior Collateral shall be deemed to have been made in reliance upon this Agreement. The Offtaker expressly waives all notice of the acceptance of and reliance on this Agreement by the Senior Agent and the Senior Lenders.

Section 4.13 Waiver of Certain Claims By the Borrower, etc. To the extent permitted by Applicable Law, Borrower and each subsidiary of Borrower shall not assert, and hereby waives any claim against each Intercreditor Party on any theory of liability for special, indirect, consequential or punitive damages (as opposed to direct or actual damages) arising out of, in connection with, or as a result of, this Agreement or any agreement or instrument contemplated hereby.

Section 4.14 Application to Other Agreements between Offtaker and Borrower. The parties hereto acknowledge that this Agreement is not intended to, and shall not, apply to any agreements, contracts or other arrangements (including, without limitation, interconnection agreements, transmission agreements, construction services agreements, and retail service agreements) between Offtaker and Borrower other than the Subordinated Obligations, the Subordinated Security Documents and the Power Purchase Agreement.

Section 4.15 Acknowledgment by the Borrower. By executing the acknowledgment to this Agreement, the Borrower agrees to all the terms hereof and shall not, either directly or indirectly, take any action to challenge or otherwise impair in any respect the operation hereof. Notwithstanding the foregoing, the Borrower is not a party to this Agreement and a separate acknowledgment by the Borrower shall not be required with respect to any amendment, supplement or waiver hereto.

IN WITNESS WHEREOF, the parties hereto have executed this Agreement as of the day and year first above written.

SENIOR AGENT:

_____, as Administrative Agent

By: _____
Name:
Title:

OFFTAKER:

SOUTHERN CALIFORNIA EDISON

By: _____
Name:
Title:

ACKNOWLEDGED AND AGREED:

[]

By: _____
Name:
Title:

Annex A

Description of Real Property

The contents of this document are subject to restrictions on disclosure as set forth herein.

State of California

County of _____

On _____ before me, (here insert name and title of the officer), personally appeared _____, personally known to me (or proved to me on the basis of satisfactory evidence) to be the person(s) whose name(s) is/are subscribed to the within instrument and acknowledged to me that he/she/they executed the same in his/her/their authorized capacity(ies), and that by his/her/their signature(s) on the instrument the person(s), or the entity upon behalf of which the person(s) acted, executed the instrument.

WITNESS my hand and official seal.

Signature _____

(Seal)

State of California

County of _____

On _____ before me, (here insert name and title of the officer), personally appeared _____, personally known to me (or proved to me on the basis of satisfactory evidence) to be the person(s) whose name(s) is/are subscribed to the within instrument and acknowledged to me that he/she/they executed the same in his/her/their authorized capacity(ies), and that by his/her/their signature(s) on the instrument the person(s), or the entity upon behalf of which the person(s) acted, executed the instrument.

WITNESS my hand and official seal.

Signature _____

(Seal)

State of California

County of _____

On _____ before me, (here insert name and title of the officer), personally appeared _____, personally known to me (or proved to me on the basis of satisfactory evidence) to be the person(s) whose name(s) is/are subscribed to the within instrument and acknowledged to me that he/she/they executed the same in his/her/their authorized capacity(ies), and that by his/her/their signature(s) on the instrument the person(s), or the entity upon behalf of which the person(s) acted, executed the instrument.

WITNESS my hand and official seal.

Signature _____

(Seal)

*** End of EXHIBIT U***

AMENDMENT NO. 1
To The
GENERATING FACILITY POWER PURCHASE AND SALE AGREEMENT
Between
SOUTHERN CALIFORNIA EDISON COMPANY
And
ALTA WIND VI, LLC

RAP ID #6319

This Amendment No. 1 ("Amendment No. 1") to the Agreement (as that term is defined below) is entered into between Southern California Edison Company, a California corporation ("SCE"), and Alta Wind VI, LLC, a Delaware limited liability company ("Seller"). SCE and Seller are hereinafter sometimes referred to individually as a "Party" and jointly as the "Parties". Capitalized terms used and not otherwise defined in this Amendment No. 1 shall have the meanings ascribed to such terms in the Agreement.

RECITALS

This Amendment No. 1 is entered into between the Parties with reference to the following facts:

- A. SCE and Seller are Parties to that certain Generating Facility Power Purchase and Sale Agreement, dated as of April 22, 2010 (as amended from time to time, the "Agreement"), under which, among other things, Seller will sell to SCE, and SCE will purchase from Seller, Product upon commencement of the Term.
- B. Seller wishes to sell to SCE, and SCE wishes to purchase from Seller, Pre-Term Product during the Startup Period, on the terms and conditions set forth herein.
- C. SCE and Seller have agreed that Seller shall provide an additional Three Million Three-Hundred Sixty-Three Thousand Seven Hundred Fifty Dollars (\$3,363,750) of Performance Assurance in lieu of the Secured Interests required under Section 8.04 of the Agreement on the terms and conditions specified in this Amendment No. 1.
- D. The Parties now wish to amend the Agreement in accordance with the intentions of the Parties described above.

The contents of this document are subject to restrictions on disclosure as set forth in the Agreement.

AMENDMENT

NOW, THEREFORE, in consideration of the promises, mutual covenants and agreements hereinafter set forth, and for other good and valuable consideration, as set forth herein, the Parties agree to amend the Agreement as follows:

1. Amendment to Section 1.06: Performance Assurance Amount.

Section 1.06 is hereby deleted in its entirety and replace with the following:

“1.06 Performance Assurance Amount.

One Hundred Nine Thousand Nine Hundred Twenty Five Dollars (\$109,925) per MW of Nameplate Contract Capacity.”

2. Amendments With Respect to Secured Interest Provisions.

(a) Section 2.03(b)(iv)(9) is hereby deleted in its entirety and replaced with the following:

“[Intentionally Deleted]”.

(b) Section 2.05(a)(xiii) is hereby deleted in its entirety and replaced with the following:

“[Intentionally Deleted]”.

(c) Section 6.01(d)(iv) is hereby deleted in its entirety and replaced with the following:

“[Intentionally Deleted]”.

(d) Section 8.04 is hereby deleted in its entirety and replaced with the following:

“8.04 [Intentionally Deleted]”.

(e) Section 8.05(a) is hereby deleted in its entirety and replaced with the following:

“(a) Seller shall, from time to time as requested by SCE, execute, acknowledge, record, register, deliver and/or file all such notices, statements, instruments and other documents as may be necessary or advisable to render fully valid and enforceable under all applicable laws the rights, liens and priorities of SCE with respect to the Security Interest provided for herein;”.

(f) Section 8.05(d) is hereby deleted in its entirety and replaced with the following:

The contents of this document are subject to restrictions on disclosure as set forth in the Agreement.

“(d) Except for liens for the benefit of Lender, Seller shall not create, incur, assume or suffer to be created by it or any subcontractor, employee, laborer, materialman, other supplier of goods or services or any other person, any lien on Seller’s interest (or any part thereof) in this Power Purchase Agreement, the Site or the Generating Facility. Seller promptly shall pay or discharge, or shall cause its contractors to promptly pay and discharge, and discharge of record, any such lien for labor, materials, supplies or other obligations upon Seller’s interest in the Site, the Generating Facility, or a material part thereof. or interest therein, unless Seller is disputing any such lien in good faith and only for so long as it does not create an imminent risk of a sale or transfer of the Generating Facility or a material part thereof;”.

(g) Section 8.06 is hereby deleted in its entirety and replaced with the following:

“8.06 [Intentionally Deleted]”.

(h) Section 10.10(a) is hereby amended by renumbering the second clause (xii) (beginning with the words “The recording of the Security Documents”) as clause (xiv) and renumbering the second clause (xiii) (beginning with the words “The disclosure of the Right of First Offer”) as clause (xv).

(i) Section 10.10(a)(xiv) is hereby deleted in its entirety and replaced with the following:

“(xiv) The Notice of Right of First Offer pursuant to Section 2.05(b)(i)(1).”

(j) Section 12.04 is hereby deleted in its entirety and replaced with the following:

“12.04 [Intentionally Deleted]”.

(k) Exhibit T [Form of Subordinated Leasehold Deed of Trust, Security Agreement, Assignment of Rents and Leases and Fixture Filing] and Exhibit U [Form of Intercreditor and Subordination Agreement] are hereby deleted in their entirety.

3. A new Section 2.02(d) is added as follows:

“(d) Seller's Responsibilities Prior to Initial Synchronization

On or prior to Initial Synchronization, Seller shall fulfill the requirements of Sections 2.03(b)(iv)(1) through (7), (10) and (11).”

4. Section 2.03(b)(iv)(5) of the Agreement is hereby deleted in its entirety and replaced with the following:

“(5) [Intentionally Deleted]”.

The contents of this document are subject to restrictions on disclosure as set forth in the Agreement.

5. A new Section 2.03(b)(v) is hereby added to the Agreement as follows:
- “(v) Seller shall (i) apply for CEC Certification and Verification within ten (10) days after the Initial Operation Date; (ii) provide SCE with a copy of such application; and (iii) thereafter diligently pursue obtaining CEC Certification and Verification; *provided that*, such CEC Certification and Verification shall not be required to the extent that Seller is unable to obtain CEC Certification and Verification because of a change in the RPS Legislation, or the rules or regulations relating thereto, occurring after the Master Agreement Effective Date; *provided further that*:
- (1) The Generating Facility would have qualified for CEC Certification and Verification under the RPS Legislation, and the rules and regulations relating thereto, as of the Master Agreement Effective Date; and
 - (2) Seller has made commercially reasonable efforts to obtain CEC Certification and Verification under the then current Applicable Law. Seller shall not be required to incur out of pocket costs in excess of \$25,000 in any year in order to obtain CEC Certification and Verification under the then current Applicable Law.”
6. Section 3.01(f) of the Agreement is deleted in its entirety and replaced with the following:
- “From the Power Purchase Agreement Effective Date, Seller shall not sell any Product or Pre-Term Product to any entity other than SCE.”
7. A new paragraph is added, Section 3.06 (d) as follows:
- “(d) Check Meter. SCE may, at its sole cost, furnish and install one Check Meter at the interconnection associated with the Generating Facility at a location agreed upon by the Parties.”
8. Amendments With Respect to NERC Provisions.
- (a) A new paragraph is added to Section 3.10(c) immediately after the first paragraph as follows:

“Seller shall maintain documentation of all procedures applicable to the testing and maintenance of the Generating Facility protective devices as necessary to comply with NERC Reliability Standards applicable to protection systems for large electric generators, if Seller is required to be a registered entity pursuant to the NERC Reliability Standards.”
 - (b) A new Section 3.10(h) is added as follows:

“(h) Seller shall have registered with the NERC as the Generating Facility’s

Generator Owner and Generator Operator if Seller is required to be a registered entity pursuant to the NERC Reliability Standards.”

- (c) A new Section 3.20 is added as follows:

“3.20 NERC Electric System Reliability Standards.

Throughout the Facility Term, Seller shall be:

- (a) Responsible for complying with any NERC Reliability Standards applicable to the Generating Facility, including registration with NERC as the Generator Operator for the Generating Facility or other applicable category under the NERC Reliability Standards and implementation of all applicable processes and procedures required by NERC, WECC or ISO for compliance with the NERC Reliability Standards; and
- (b) Liable for all penalties assessed by NERC (through WECC or otherwise) for violations of the NERC Reliability Standards by the Generating Facility or Seller, as Generator Operator or other applicable category.

However, if Seller learns that NERC (through WECC or otherwise) is considering or intends to assess Seller with a penalty that Seller believes is attributable to SCE's actions or inactions as SC as described in the document entitled “NERC Reliability Standards - Responsibilities of the Generator Operator, Scheduling Coordinator, ISO, and Reliability Coordinator” or other successor description or document on the ISO website at the time of the potential assessment, Seller shall provide SCE with sufficient notice to allow SCE to take part in administrative processes, discussions or settlement negotiations with NERC, WECC or other entity arising from or related to the alleged violation or possible penalty. If the penalty is nonetheless assessed in spite of SCE's participation in the processes, discussions or settlement negotiations, or SCE waives its right to take part in the processes, discussion or settlement negotiations, SCE shall be responsible for the penalty to the extent that it was solely caused by SCE's actions or inactions as SC as described in the document entitled “NERC Reliability Standards - Responsibilities of the Generator Operator, Scheduling Coordinator, ISO, and Reliability Coordinator” or other successor description or document on the ISO website at the time of the violation. If Seller is assessed and pays the penalty to NERC and such penalty is later determined to be SCE's responsibility as set forth in this Section 3.20, then SCE shall promptly reimburse Seller upon it being established to SCE's reasonable satisfaction that the penalty was actually assessed against Seller by NERC and paid by Seller to NERC.

9. The first paragraph of Section 3.19(b) is deleted in its entirety and replaced with the following:

The contents of this document are subject to restrictions on disclosure as set forth in the Agreement.

“During the Startup Period and, unless otherwise specified by Seller in accordance with the terms of this Agreement, during the Facility Term, SCE shall act as Seller’s Scheduling Coordinator and the following provisions shall apply:”

10. Section 3.19(b)(ii)(1) of the Agreement is deleted in its entirety and replaced with the following:

“At least thirty (30) days before Initial Synchronization, Seller shall take all actions and execute and deliver to SCE all documents necessary to authorize or designate SCE as Seller’s Scheduling Coordinator.”

11. Section 3.19(b)(viii)(1) of the Agreement is deleted in its entirety and replaced with the following:

“During the Startup Period, SCE will Schedule the Pre-Term Product in accordance with the ISO Tariff and will coordinate with Seller and the ISO to facilitate Seller’s testing of the Generating Facility.”

12. Section 4.01(b) of the Agreement is deleted in its entirety and replaced with the following:

“SCE shall make monthly Pre-Term Product Payments to Seller during the Startup Period calculated in the manner described in Section 4.02(a)(iii).”

13. A new Section 4.02(a)(iii) of the Agreement is added as follows:

“During the Startup Period, monthly Pre-Term Product Payments shall be calculated pursuant to the following formula:

$$Payment_m = \sum_{h=1}^{n_m} P_h \cdot Q_h$$

Payment_m = the payment in month m

M = the payment month

H = hour h of the payment month

n_m = the total hours in the payment month m

Q_h = the Delivered Amounts for hour h

P_h = the Pre-Term Product Price in hour h

14. Section 4.03(a)(iv)(1) of the Agreement is deleted in its entirety and replaced with the following:

The contents of this document are subject to restrictions on disclosure as set forth in the Agreement.

“[Intentionally Deleted.]”

15. Section 4.03(b)(i) of the Agreement is deleted in its entirety and replaced with the following:

“[Intentionally Deleted.]”

16. Section 4.05(b)(ii) of the Agreement is deleted in its entirety and replaced with the following:

“[Intentionally Deleted.]”

17. Amendment to Section 10.02: Additional Representations, Warranties and Covenants; Deletion of Section 10.18.

(a) New Sections 10.02(e) through (h) are added as follows:

“(e) Seller, and, if applicable, its successors, represents and warrants that throughout the Delivery Term of this Agreement that:

(i) Subject to Section 2.03(b)(v), the Project qualifies and is certified by the CEC as an Eligible Renewable Energy Resource (“ERR”) as such term is defined in Public Utilities Code Section 399.12 or Section 399.16; and

(ii) The Project’s output delivered to Buyer qualifies under the requirements of the California Renewables Portfolio Standard.

To the extent a change in law occurs after execution of this Agreement that causes this representation and warranty to be materially false or misleading, it shall not be an Event of Default if Seller has used commercially reasonable efforts to comply with such change in law.

(f) Seller and, if applicable, its successors, represents and warrants that throughout the Delivery Term of this Agreement the Renewable Energy Credits transferred to Buyer conform to the definition and attributes required for compliance with the California Renewable Portfolio Standard, as set forth in California Public Utilities Commission Decision 08-08-028, and as may be modified by subsequent decision of the California Public Utilities Commission or by subsequent legislation. To the extent a change in law occurs after execution of this Agreement that causes this representation and warranty to be materially false or misleading, it shall not be an Event of Default if Seller has used commercially reasonable efforts to comply with such change in law.

- (g) The term “commercially reasonable efforts” as used in Sections 10.02(e) or 10.02(f) shall not require Seller to incur out of pocket costs in excess of Twenty-Five Thousand dollars (\$25,000) in any year in order to comply with the then-current Applicable Law as it applies to Seller’s obligations under those Sections.
- (h) Seller warrants that all necessary steps to allow the renewable energy credits transferred to Buyer to be tracked in the Western Renewable Energy Generation Information System will be taken prior to the first delivery under the contract.”
- (b) Section 10.18 is hereby deleted in its entirety.

18. Amendment to Section 10.07; Governing Law.

Section 10.07 is deleted in its entirety and replaced with the following:

“10.07 Governing Law.

THIS AGREEMENT AND THE RIGHTS AND DUTIES OF THE PARTIES HEREUNDER SHALL BE GOVERNED BY AND CONSTRUED, ENFORCED AND PERFORMED IN ACCORDANCE WITH THE LAWS OF THE STATE OF CALIFORNIA, WITHOUT REGARD TO PRINCIPLES OF CONFLICTS OF LAW. TO THE EXTENT ENFORCEABLE AT SUCH TIME, EACH PARTY WAIVES ITS RESPECTIVE RIGHT TO ANY JURY TRIAL WITH RESPECT TO ANY LITIGATION ARISING UNDER OR IN CONNECTION WITH THIS AGREEMENT.”

19. Exhibit A is amended by adding the following defined terms in alphabetical order:

- (a) “Amendment No. 1” means the first amendment to this Agreement.
- (b) “Amendment No. 1 Effective Date” means the date upon which the last Party executes Amendment No. 1.
- (c) “Check Meter” means the SCE revenue-quality meter section(s) or meter(s), which SCE may require at its discretion, and which will include those devices normally supplied by SCE or Seller under the applicable utility electric service requirements.”
- (d) “Generator Operator” means the entity that Operates the Generating Facility and performs the functions of supplying energy and interconnected operations services as described in the NERC Reliability Standards.
- (e) “Generator Operator Obligations” means the obligations of a Generator Operator as set forth in all applicable NERC Reliability Standards.

- (f) “Generator Owner” means an entity that owns the Generating Facility and has registered with NERC as the entity responsible for complying with those NERC Reliability Standards applicable to owners of generating units as set forth in the NERC Reliability Standards.
- (g) “Generator Owner Obligations” means the obligations of a Generator Owner as set forth in all applicable NERC Reliability Standards.
- (h) “NERC” means the North American Electric Reliability Corporation, or any successor thereto.
- (i) “Locational Marginal Price” has the meaning set forth in the ISO Tariff.
- (j) “NERC Reliability Standards” means those reliability standards applicable to the Generating Facility, or to the Generator Owner or the Generator Operator with respect to the Generating Facility, that are adopted by NERC and approved by the applicable regulatory authorities.
- (k) “NERC Standards Non-Compliance Penalties” means any and all monetary fines, penalties, damages, interest or assessments by the NERC, ISO, WECC, a Governmental Authority or any entity acting at the direction of a Governmental Authority arising from or relating to a failure to perform the obligations of Generator Operator or Generator Owner as set forth in the NERC Reliability Standards.
- (l) “PNode” has the meaning set forth in the ISO Tariff.
- (m) “Pre-Term Product” means Product delivered during the Startup Period.
- (n) “Pre-Term Product Payment” means the amount calculated pursuant to Section 4.02 (a)(iii).
- (o) “Pre-Term Product Price” means, for each hour, the lowest of the following prices:
 - (i) the Energy Price;
 - (ii) the 20-year 2008 Market Price Referent Schedule as set forth in CPUC Resolution E-4214 (dated December 18, 2008), corresponding to the year in which the Pre-Term Product is delivered; or
 - (iii) the average applicable Real-Time Price (P_h) attributable to Delivered Amounts in that hour, plus \$14.99/MWh, which shall be calculated pursuant to the following formula:

$$\sum_{i_h = 1}^{S_h} \frac{P_{i_h}}{S_h} + \$14.99$$

P_{i_h}

= the Real-Time Price in interval i in hour h

S_h

= the number of Settlement Intervals in hour h

i_h

= Settlement Interval i in hour h

$$\sum_{i_h = 1}^{S_h} \frac{P_{i_h}}{S_h}$$

= the average Real-Time Price in hour h

- (p) “Real-Time Market” has the meaning set forth in the ISO Tariff.
- (q) “Real-Time Price” means (i) the ISO Real-Time PNode Market Locational Marginal Price, as published in OASIS, for electric energy in each applicable Settlement Interval (including the energy, congestion and losses components) at the Generating Facility’s PNode (as published by the ISO) which is the pricing point used by the CAISO for settlements of this Generating Facility, or (ii) if the ISO has not established a Locational Marginal Price at the Generating Facility’s PNode (as published by the ISO), then the ISO Real-Time Market Locational Marginal Price, as published in OASIS, for electric energy in each applicable Settlement Interval (including the energy, congestion and losses components) at the SP-15 EZ Gen Hub.

20. Amendment to Exhibit A: Defined Terms.

Exhibit A is amended as follows:

- (a) The definition of “Delivery Point” is deleted and replaced with the following:

“Delivery Point” means the PNode assigned by the ISO to the Generating Facility at the Windhub Substation where the Generating Facility interconnects to the ISO Grid.
- (b) In the defined terms, “Green Attributes” is deleted in its entirety and replaced with the following:

The contents of this document are subject to restrictions on disclosure as set forth in the Agreement.

“Green Attributes” means any and all credits, benefits, emissions reductions, offsets, and allowances, howsoever entitled, attributable to the generation from the Project, and its avoided emission of pollutants. Green Attributes include but are not limited to Renewable Energy Credits, as well as:

- (1) Any avoided emission of pollutants to the air, soil or water such as sulfur oxides (SO_x), nitrogen oxides (NO_x), carbon monoxide (CO) and other pollutants;
- (2) Any avoided emissions of carbon dioxide (CO₂), methane (CH₄), nitrous oxide, hydrofluorocarbons, perfluorocarbons, sulfur hexafluoride and other greenhouse gases (GHGs) that have been determined by the United Nations Intergovernmental Panel on Climate Change, or otherwise by law, to contribute to the actual or potential threat of altering the Earth’s climate by trapping heat in the atmosphere;¹
- (3) The reporting rights to these avoided emissions, such as Green Tag Reporting Rights.

Green Tag Reporting Rights are the right of a Green Tag Purchaser to report the ownership of accumulated Green Tags in compliance with federal or state law, if applicable, and to a federal or state agency or any other party at the Green Tag Purchaser’s discretion, and include without limitation those Green Tag Reporting Rights accruing under Section 1605(b) of The Energy Policy Act of 1992 and any present or future federal, state, or local law, regulation or bill, and international or foreign emissions trading program. Green Tags are accumulated on a MWh basis and one Green Tag represents the Green Attributes associated with one (1) MWh of energy.

Green Attributes do not include:

- (i) Any energy, capacity, reliability or other power attributes from the Project,
- (ii) Production tax credits associated with the construction or operation of the Project and other financial incentives in the form of credits, reductions, or allowances associated with the Project that are applicable to a state or federal income taxation obligation,

¹ Avoided emissions may or may not have any value for GHG compliance purposes. Although avoided emissions are included in the list of Green Attributes, this inclusion does not create any right to use those avoided emissions to comply with any GHG regulatory program.

- (iii) Fuel-related subsidies or “tipping fees” that may be paid to Seller to accept certain fuels, or local subsidies received by the generator for the destruction of particular preexisting pollutants or the promotion of local environmental benefits, or
- (iv) Emission reduction credits encumbered or used by the Project for compliance with local, state, or federal operating and/or air quality permits.

If the Project is a biomass or biogas facility and Seller receives any tradable Green Attributes based on the greenhouse gas reduction benefits or other emission offsets attributed to its fuel usage, it shall provide Buyer with sufficient Green Attributes to ensure that there are zero net emissions associated with the production of electricity from the Project.

- (c) The following defined terms are hereby deleted in their entirety: “Permitted Lien,” “Secured Interest,” “Security Documents,” “Senior Lender” and “Subordination Agreement.”
- (d) Any references to “Senior Lender” set forth in the Agreement shall be replaced with “Lender.”
- (e) The defined term “Senior Loan” is hereby deleted in its entirety and replaced with the following:

““Senior Loan” means a loan provided by a Lender.”

21. Amendment to Exhibit B: Final Notice To Proceed

Exhibit B is hereby amended as follows:

- (a) The Site Description in Section 2 of Exhibit 1 to Final Notice Proceed is hereby deleted in its entirety and replaced with the following:

2. Site Description.

The Alta Wind VI Energy Center site will be located on portions of sections 1, 2, and 3 in Township 10N, Range 13W SBB&M, on portions of sections 14, 15, 19, 20, 21, 22, 23, 26, 27, 28, 29, 30, 32, 33, 34, and 35 in Township 11N, Range 13W SBB&M, and on portions sections 13, 14, 15, 16, 17, 22, 23, 24, and 25 in T11N R 14W SBB&M in Kern County, CA.

- (b) The Site Map attachment to Exhibit 1 to Final Notice Proceed is hereby deleted in its entirety and replaced with the Site Map attachment attached to this Amendment as Exhibit A.

The contents of this document are subject to restrictions on disclosure as set forth in the Agreement.

22. MISCELLANEOUS

- (a) CPUC Approval of Amendment No. 1 and Seller Indemnification for CPUC Disallowance.

SCE shall include this Amendment No. 1 in its 2011 Energy Resource Recovery Account (ERRA) application to the CPUC, which SCE anticipates will be filed on or about April 1, 2012. Seller shall indemnify and hold SCE harmless from and against any disallowance by the CPUC of any amounts paid by SCE to Seller for Pre-Term Product under this Amendment No. 1 (“Disallowance”); *provided, however,* that Seller’s indemnity obligation under this Section 20(a) shall expire on the date that any decision by the CPUC approving SCE’s 2011 ERRA application and any payments made by SCE to Seller pursuant to the Amendment No. 1 becomes final and non-appealable. If Seller is required to make an indemnification payment to SCE pursuant to this Section 20(a) for any Disallowance by the CPUC, then the Parties agree to work in good faith to restructure the purchase/sale of Pre-Term Product or otherwise resolve the Disallowance in a manner acceptable to both Parties. If within thirty (30) days the Parties fail to successfully restructure the purchase/sale of Pre-Term Product or otherwise reach agreement on an acceptable resolution of the Disallowance, then SCE shall have the option, upon Notice within five (5) Business Days after such failure, to accept the Disallowance and retain for its sole use and account all Pre-Term Product. If SCE does not elect to accept the Disallowance within the required period of time, then:

- (i) Seller, with respect to any and all Pre-Term Product that has been delivered to and paid for by SCE under this Amendment, shall have the option to either:
- (1) make the required indemnification payment to SCE and allow SCE to retain for SCE’s sole use and account all Pre-Term Product; or
 - (2) refund to SCE the greater of (A) the amount of the Disallowance, or (B) the difference between the Pre-Term Product Price and the applicable Real-Time Price, and, notwithstanding anything to the contrary in the Agreement, upon receipt of such refund SCE shall return the associated Green Attributes to Seller for Seller’s sole use and account or sales to one or more third parties.
- (b) Reservation of Rights. Each of the Parties expressly reserves all of its respective rights and remedies under the Agreement.
- (c) Legal Effect. Except as expressly modified as set forth herein, the Agreement remains unchanged and, as so modified, the Agreement shall remain in full force and effect.

- (d) Governing Law. THIS AMENDMENT NO. 1 AND THE RIGHTS AND DUTIES OF THE PARTIES HEREUNDER SHALL BE GOVERNED BY AND CONSTRUED, ENFORCED AND PERFORMED IN ACCORDANCE WITH THE LAWS OF THE STATE OF CALIFORNIA, WITHOUT REGARD TO PRINCIPLES OF CONFLICTS OF LAW. TO THE EXTENT ENFORCEABLE AT SUCH TIME, EACH PARTY WAIVES ITS RESPECTIVE RIGHT TO ANY JURY TRIAL WITH RESPECT TO ANY LITIGATION ARISING UNDER OR IN CONNECTION WITH THIS AMENDMENT NO. 1.
- (e) Successors and Assigns. This Amendment No. 1 shall be binding upon and inure to the benefit of the Parties hereto and their respective successors and assigns.
- (f) Authorized Signatures; Notices. Each Party represents and warrants that the person who signs below on behalf of that Party has authority to execute this Amendment No. 1 on behalf of such Party and to bind such Party to this Amendment No. 1. Any written notice required to be given under the terms of this Amendment No. 1 shall be given in accordance with the terms of the Agreement.
- (g) Effective Date. This Amendment No. 1 shall be deemed effective as of the date upon which the last Party executes this Amendment No. 1 (“Amendment No. 1 Effective Date”).
- (h) Further Agreements. This Amendment No. 1 shall not be amended, changed, modified, abrogated or superseded by a subsequent agreement unless such subsequent agreement is in the form of a written instrument signed by the Parties.
- (i) Counterparts; Electronic Signatures. This Amendment No. 1 may be executed in one or more counterparts, each of which will be deemed to be an original of this Amendment No. 1 and all of which, when taken together, will be deemed to constitute one and the same agreement. The exchange of copies of this Amendment No. 1 and of signature pages by facsimile transmission, Portable Document Format (i.e., PDF), or by other electronic means shall constitute effective execution and delivery of this Amendment No. 1 as to the Parties and may be used in lieu of the original Amendment No. 1 for all purposes.

[Remainder of Page Left Intentionally Blank.]

RAP ID #6319, ALTA Wind VI, LLC

IN WITNESS WHEREOF, the Parties hereto have caused this Amendment No. 1 to be executed by their duly authorized representatives on the dates indicated below their respective signatures.

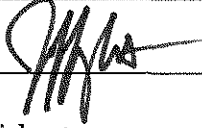
ALTA WIND VI, LLC a Delaware limited liability company.	SOUTHERN CALIFORNIA EDISON COMPANY, a California corporation.
By:  _____ <i>Jeff Cast</i> <i>Vice President</i>	By: _____ <i>[Name]</i> <i>[Title]</i>
Date: _____	Date: _____

The contents of this document are subject to restrictions on disclosure as set forth in the Agreement.

IN WITNESS WHEREOF, the Parties hereto have caused this Amendment No. 1 to be executed by their duly authorized representatives on the dates indicated below their respective signatures.

ALTA WIND VI, LLC a Delaware limited liability company.	SOUTHERN CALIFORNIA EDISON COMPANY, a California corporation.
By: _____ [Name] [Title]	By:  [Name] [Title] Marc Ulrich Vice President Renewable and Alternative Power
Date: _____	Date: <u>5/4/2011</u>

The contents of this document are subject to restrictions on disclosure as set forth in the Agreement.

**EXHIBIT A
SITE MAP ATTACHMENT**

Intended For

**Exhibit 1 to Exhibit B (Notice to Proceed) of the
Generating Facility Power Purchase and Sale Agreement**

[Attached to Following Page]

(Subject to Change)

ALTA WIND VI ENERGY CENTER

Revision: C

Date: 03/31/2011

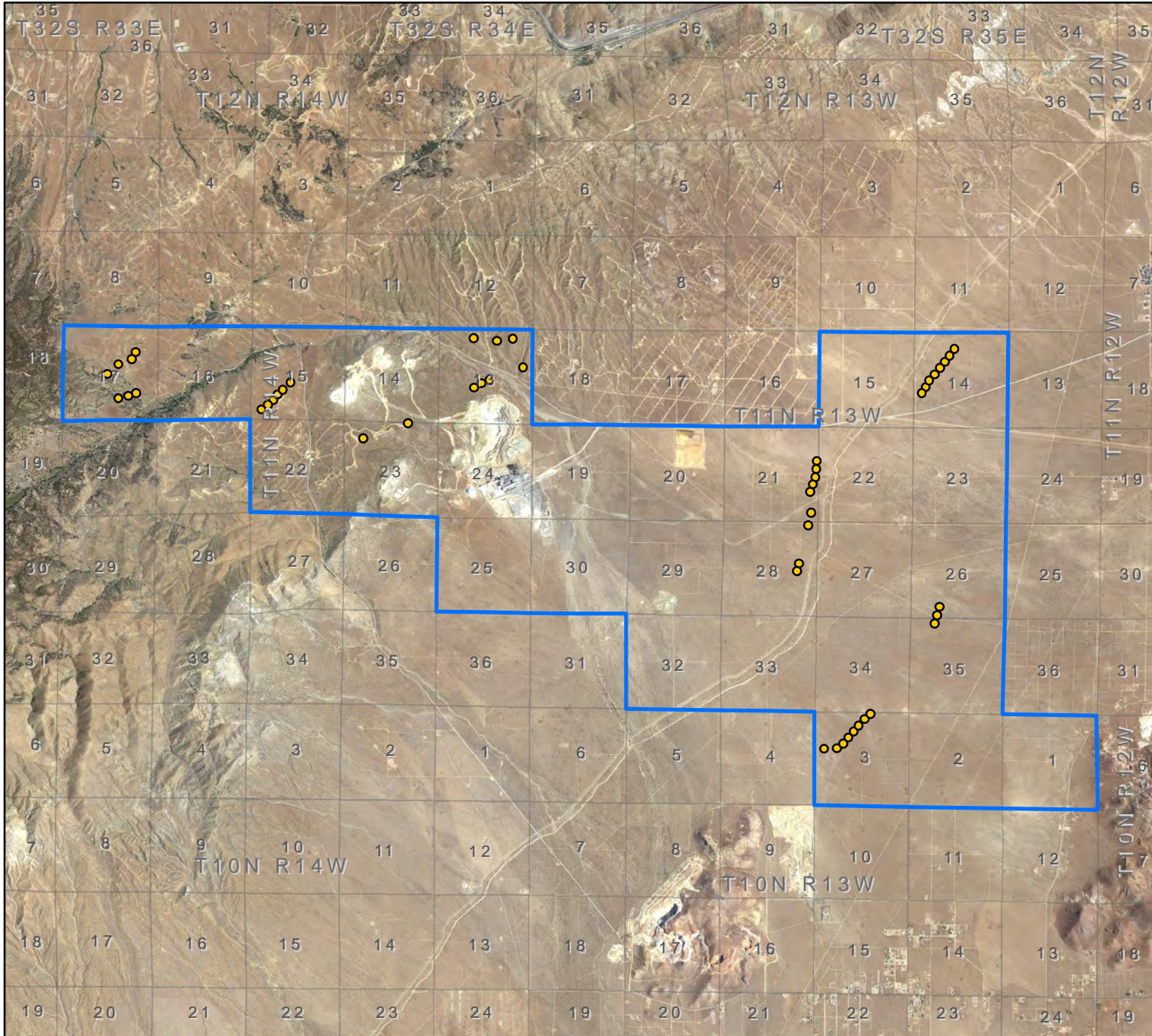

 Alta VI Project Boundary

 Alta VI Layout

Notes:
The Site consists of portions of the outlined property, some of which may be shared from time to time with other parties.

