



SOUTHERN CALIFORNIA  
**EDISON**

An *EDISON INTERNATIONAL* Company

**RENEWABLE POWER PURCHASE AND SALE AGREEMENT**

*between*

**SOUTHERN CALIFORNIA EDISON COMPANY**

*and*

***SOLAR STAR CALIFORNIA XX, LLC***

(RAP ID #5413)

**TABLE OF CONTENTS**

**PREAMBLE AND RECITALS** ..... 1

**ARTICLE ONE. SPECIAL CONDITIONS** ..... 2

1.01 Generating Facility..... 2

1.02 Forecasted Initial Synchronization Date..... 4

1.03 Forecasted Commercial Operation Date..... 5

1.04 Commercial Operation Deadline..... 5

1.05 Firm Operation Date..... 5

1.06 Term..... 5

1.07 Product Price..... 6

1.08 Performance Assurance Amount..... 6

1.09 Seller’s Guarantor..... 6

1.10 Compliance Expenditure Cap and Curtailment Cap..... 6

1.11 Interconnection Queue Position..... 7

1.12 Federal Tax Credit..... 7

**ARTICLE TWO. TERM AND CONDITIONS PRECEDENT; TERMINATION** ... 8

2.01 Effective Date and Obligations prior to Effective Date..... 8

2.02 Obligations Prior to Commencement of the Term..... 8

2.03 Conditions Precedent to Commencement of Term..... 9

2.04 Termination Rights..... 10

2.05 [Intentionally Omitted.] ..... 12

2.06 Rights and Obligations Surviving Termination..... 12

**ARTICLE THREE. SELLER’S OBLIGATIONS** ..... 15

3.01 Conveyance of Entire Output, Conveyance of Green Attributes, Capacity  
Attributes and Resource Adequacy Benefits..... 15

3.02 Resource Adequacy Rulings..... 16

3.03 Maintenance as ERR..... 16

3.04 Allocation of Availability Incentive Payments and Non-Availability Charges..... 16

3.05 Permits, Interconnection and Transmission Service Agreements, and CAISO Tariff  
Compliance..... 17

3.06 Development Security..... 17

3.07 Seller’s Energy Delivery Obligation..... 23

3.08 Metering, Communications, Telemetry and Meteorological Station(s)..... 24

3.09 Site Location and Control..... 27

3.10 Change in Structure, Ownership or Financing..... 28

3.11 Design..... 28

3.12 Operation and Record Keeping..... 29

3.13 Obtaining Scheduling Coordinator Services..... 31

3.14 Installation of Generating Facility in Increments..... 32

3.15 Forecasting..... 32

3.16 Scheduled Outages..... 32

*The contents of this document are subject to restrictions on disclosure as set forth herein.*

3.17 Progress Reporting Toward Meeting Milestone Schedule. ....33

3.18 Provision of Information.....34

3.19 SCE’s Access Rights.....35

3.20 Obtaining and Maintaining CEC Certification, and CEC Verification. ....35

3.21 Notice of Cessation or Termination of Service Agreements. ....36

3.22 Payments and Invoicing.....36

3.23 Lost Output Report. ....36

3.24 Actual Availability Report.....37

3.25 Seller’s Provision of Historic Solar Data.....37

3.26 NERC Electric System Reliability Standards.....38

3.27 Application of Prevailing Wage.....39

**ARTICLE FOUR. SCE’s OBLIGATIONS.....40**

4.01 Obligation to Pay and Invoice.....40

4.02 Obligations Under MRTU or Equivalent Successor Market. ....40

4.03 SCE’s Check Meter.....42

4.04 Scheduling Coordinator. ....43

4.05 Termination of Scheduling Coordinator.....43

4.06 Exclusive Rights to Product and Cost Responsibility.....44

4.07 Interest Payments on Cash Deposits.....44

**ARTICLE FIVE. FORCE MAJEURE.....45**

5.01 No Default for Force Majeure.....45

5.02 Requirements Applicable to the Claiming Party. ....45

5.03 Commercial Operation Deadline Extension. ....46

5.04 Firm Operation Date Extension. ....46

5.05 Termination.....46

**ARTICLE SIX. EVENTS OF DEFAULT; REMEDIES .....48**

6.01 Events of Default. ....48

6.02 Early Termination. ....52

6.03 Termination Payment.....52

**ARTICLE SEVEN. LIMITATIONS OF LIABILITIES .....54**

**ARTICLE EIGHT. CREDIT AND COLLATERAL REQUIREMENTS .....56**

8.01 Financial Information.....56

8.02 Performance Assurance. ....57

8.03 First Priority Security Interest in Cash or Cash Equivalent Collateral. ....59

8.04 Credit and Collateral Covenants. ....60

8.05 Commercial Code Waiver.....61

8.06 Substitution of Performance Assurance.....61

**ARTICLE NINE. GOVERNMENTAL CHARGES .....63**

9.01 Cooperation to Minimize Tax Liabilities.....63

9.02 Governmental Charges.....63

9.03 Providing Information to Taxing Authorities. ....63

*The contents of this document are subject to restrictions on disclosure as set forth herein.*

<b>ARTICLE TEN. MISCELLANEOUS</b> .....	64
10.01 Representations and Warranties.....	64
10.02 Additional Seller Representations, Warranties and Covenants. ....	64
10.03 Indemnity.....	66
10.04 Assignment. ....	68
10.05 Consent to Collateral Assignment. ....	69
10.06 Abandonment.....	71
10.07 Governing Law. ....	71
10.08 Notices.....	71
10.09 General.....	72
10.10 Confidentiality.....	73
10.11 Insurance.....	77
10.12 Nondedication.....	79
10.13 Mobile Sierra.....	79
10.14 Simple Interest Payments.....	79
10.15 Payments.....	80
10.16 Seller Ownership and Control of Generating Facility. ....	80
10.17 Required Material. ....	80
<b>ARTICLE ELEVEN. CHANGE IN ELECTRIC MARKET DESIGN</b> .....	81
<b>ARTICLE TWELVE. MEDIATION AND ARBITRATION</b> .....	82
12.01 Dispute Resolution.....	82
12.02 Mediation.....	82
12.03 Arbitration.....	83
12.04 Provisional Relief.....	85
<b>SIGNATURES</b> .....	86

## LIST OF EXHIBITS

- A. Definitions.
- B-1. Generating Facility and Site Description.
- B-2. Single-Line Diagram of the CAISO-Controlled Grid Interconnection.
- C. Notice List.
- D. Forecasting and Scheduling Requirements and Procedures.
- E. Payments and Invoicing.
- F. Product Replacement Damage Amount.
- G-1. Seller's Milestone Schedule.
- G-2. Seller's Material Permits.
- H. Milestone Progress Reporting Form.
- I. Form of Guaranty Agreement.
- J. Non-Disclosure Agreement.
- K. Time of Delivery Periods and Product Payment Allocation Factors.
- L. Procedure for Partial or Full Return of Development Security.
- M. Seller's Estimate of Lost Output.
- N. Form of Letter of Credit.
- O. Product Price.
- P. [Intentionally Omitted.]
- Q. SCE Penalties and CAISO Sanctions.
- R. [Intentionally Omitted.]
- S. Actual Availability Report.
- T. Meteorological Station Specifications.
- U. Notice of SCE's Rights.

## RENEWABLE POWER PURCHASE AND SALE AGREEMENT

between

**SOUTHERN CALIFORNIA EDISON COMPANY**

and

**SOLAR STAR CALIFORNIA XX, LLC**

**(RAP ID #5413)**

### PREAMBLE

This Renewable Power Purchase and Sale Agreement, together with the exhibits and attachments (collectively, the “Agreement”) is made and effective as of the following date: January 5, 2011 (“Effective Date”).

This Agreement is entered into between:

- (i) **Southern California Edison Company** (“SCE”), a California corporation, whose principal place of business is at 2244 Walnut Grove Avenue, Rosemead, California 91770, and
- (ii) **Solar Star California XX, LLC** (“Seller”), a Delaware limited liability company, whose principal place of business is at 1414 Harbour Way South, Richmond, California 94804.

SCE and Seller are sometimes referred to herein individually as a “Party” and jointly as the “Parties.” Unless the context otherwise specifies or requires, capitalized terms in this Agreement have the meanings set forth in Exhibit A.

### RECITALS

Seller is willing to construct, own, and Operate a Generating Facility which qualifies as of the Effective Date as an ERR, and to sell the Product to SCE pursuant to the terms and conditions set forth in this Agreement; and

SCE is willing to purchase the Product from Seller pursuant to the terms and conditions set forth in this Agreement.

## ARTICLE ONE. SPECIAL CONDITIONS

### 1.01 Generating Facility.

- (a) Name: Solar Star California XX (AVSP II).
- (b) Location of Site: 125<sup>th</sup> St. W. and Holiday Avenue in Rosamond, California 93560, as further described in Exhibit B-1.
- (c) Description: As described in Exhibit B-1.
- (d) Product: All electric energy produced by the Generating Facility throughout the Delivery Term, net of Station Use; and all Green Attributes, Capacity Attributes, and Resource Adequacy Benefits generated by, associated with or attributable to the Generating Facility throughout the Delivery Term.
- (e) Interconnection Point: The 230/500 kV Whirlwind Substation that is to be built as part of SCE's Tehachapi renewable transmission project.
- (f) Delivery Point: The first point of interconnection with the CAISO Controlled Grid.
- (g) ERR Type: Solar Photovoltaic.
- (h) Contract Capacity: 276 MW, subject to modification as set forth in this Section 1.01(h) or Section 3.06(g).
  - (i) If the Construction Permits grant Seller the authority to develop and construct some but not all of the requested 276 MW of Contract Capacity (such grant of authority, the "Reduced Capacity Authority to Construct") and the failure to obtain authority to construct the entire Contract Capacity of 276 MW is not due to any action or inaction on Seller's part, and Seller has timely completed all of its obligations and taken all necessary actions to obtain Construction Permits for the entire Contract Capacity of 276 MW, then Seller shall have a one time right, upon Notice (the "Capacity Permit Reduction Notice") to SCE given within thirty (30) days after Seller's receipt of the Reduced Capacity Authority to Construct, but in no event later than December 1, 2012, to reduce the Contract Capacity to the Permit Adjusted Contract Capacity. Seller's receipt of the Reduced Capacity Authority to Construct shall not, in and of itself, be deemed to be a failure to obtain Permit Approval for the purposes of Section 2.04(a)(ii).
  - (ii) In addition to the Permit Adjusted Contract Capacity, the Capacity Permit Reduction Notice given by Seller to SCE in accordance with Section 1.01(h)(i) must also include:
    - (1) The Actual Authorized Capacity;
    - (2) Seller's revised estimate of the Installed DC Rating in kW<sub>PDC</sub> based on the Permit Adjusted Contract Capacity; and

*The contents of this document are subject to restrictions on disclosure as set forth herein.*

- (3) A revised Exhibit B-1 describing the Generating Facility and the Site (including the finalized Site plan), in accordance with Section 3.09(a).
- (iii) SCE shall have fifteen (15) Business Days to review the Capacity Permit Reduction Notice and provide Notice to Seller disputing the Capacity Permit Reduction Notice or requesting additional information to substantiate the information in the Capacity Permit Reduction Notice. If SCE fails to provide any Notice of dispute or request for clarification in such fifteen (15) Business Day period, SCE will be deemed to have accepted the Capacity Permit Reduction Notice.
- (iv) Unless SCE provides Seller with Notice disputing the Capacity Permit Reduction Notice or requesting additional documentation to evaluate the Capacity Permit Reduction Notice, effective sixteen (16) Business Days after SCE’s receipt of the Capacity Permit Reduction Notice given in accordance with Section 1.01(h)(i):
  - (1) The Contract Capacity in this Section 1.01(h) will be deemed reduced to the Permit Adjusted Contract Capacity (subject to further modification as set forth in Section 3.06(g));
  - (2) The Installed DC Rating set forth in Section 1.01(i) will be deemed reduced to the number in kW<sub>PDC</sub>, as specified in the Capacity Permit Reduction Notice;
  - (3) So long as the provisions of Section 3.09(a) have been satisfied, Exhibit B-1 will be deemed replaced by the revised Exhibit B-1 included in the Capacity Permit Reduction Notice; and
  - (4) The Permit Capacity Reduction Amount will be retained, and the Development Security will be adjusted, in accordance with Section 3.06(h).
- (v) If the Contract Capacity is reduced pursuant to this Section 1.01(h), neither Party will have any liability for failure to purchase or deliver Product associated with or attributable to the Capacity Permit Reduction Quantity, *provided*, that the Capacity Permit Reduction Quantity will be subject to the restrictions set forth in Section 3.06(i).
- (i) Expected Annual Net Energy Production.

The Expected Annual Net Energy Production for each Term Year will be the value calculated in accordance with the following formula:

$$\begin{aligned} &\text{EXPECTED ANNUAL NET ENERGY PRODUCTION, in kWh} \\ &= A \times B \end{aligned}$$

*The contents of this document are subject to restrictions on disclosure as set forth herein.*



Where:

- A = The Installed DC Rating, in kW<sub>PDC</sub>. (As of the Effective Date, this rating is deemed to be 350,064 kW<sub>PDC</sub>, but is subject to modification in accordance with Section 1.01(h)(iv) and SCE's verification of Seller's installation of the Generating Facility pursuant to Exhibit L).
- B = Annual Energy Yield Factor in kWh of AC energy, as indicated in the following table:

<u>Term Year</u>	<u>Annual Energy Yield Factor</u>
1	2,086
2	2,075.57
3	2,065.19
4	2,054.87
5	2,044.59
6	2,034.37
7	2,024.20
8	2,014.08
9	2,004.01
10	1,993.99
11	1,984.02
12	1,974.10
13	1,964.23
14	1,954.40
15	1,944.63
16	1,934.91
17	1,925.23
18	1,915.61
19	1,906.03
20	1,896.50

1.02 Forecasted Initial Synchronization Date.

The Forecasted Initial Synchronization Date is December 1, 2013.

*The contents of this document are subject to restrictions on disclosure as set forth herein.*

## 1.03 Forecasted Commercial Operation Date.

The Forecasted Commercial Operation Date is October 31, 2016.

## 1.04 Commercial Operation Deadline.

The Commercial Operation Date must be no later than thirty-four (34) months from the Initial Synchronization Date (“Commercial Operation Deadline”), as may be extended pursuant to Section 1.04(a), 1.04(b), 3.06(c) or 5.03; *provided*, no extension under Section 1.04(a), 1.04(b) or 3.06(c)(alone or in combination) can exceed five hundred forty (540) days; and *provided further*, notwithstanding anything in this Agreement to the contrary, the Commercial Operation Deadline may not be later than April 30, 2018, plus any additional days for Force Majeure as provided in Section 5.03.

Subject to the preceding sentence, the Commercial Operation Deadline will be extended on a day-for-day basis:

- (a) For any delay in the enactment of the Federal Tax Credit Legislation beyond July 1, 2016 but only if concurrently an event of Force Majeure validly claimed by Seller in accordance with Sections 5.02 and 5.03 is reasonably anticipated by Seller to extend the Commercial Operation Date beyond December 31, 2016 and Seller provides reasonable evidence to SCE of the need for such an extension.
- (b) For the number of days of delay in reaching Commercial Operation caused solely by a No Fault Transmission Delay, so long as Seller demonstrates to SCE’s satisfaction that:
  - (i) Such No Fault Transmission Delay has occurred, and
  - (ii) Seller has completed all of its obligations with respect to the LGIA in a timely manner and taken all reasonable actions to ensure timely completion of the Project in accordance with the obligations under this Agreement.

## 1.05 Firm Operation Date.

The Firm Operation Date is the date that is thirty (30) days after Commercial Operation Date, plus any additional days for Force Majeure as provided in Section 5.04.

## 1.06 Term.

The Term commences on the Commercial Operation Date determined in accordance with Section 2.03 and ends on the later of:

- (a) The last day of the calendar month two hundred forty (240) months (twenty (20) years) from the month of the Firm Operation Date (the “Original Term”);  
or

- (b) If SCE provides Notice to Seller no later than nineteen (19) years after the Commercial Operation Date that Seller is obligated to deliver to SCE at the Delivery Point the quantity of Product that is three (3) times the quantity of Banked Curtailed Energy as of the last day of the Original Term (“Curtailed Return Term Notice”), then the Term ends on the earlier of:
  - (i) The day on which Seller has delivered to SCE at the Delivery Point the quantity of Product that is three (3) times the quantity of the Banked Curtailed Energy; or
  - (ii) Thirty-six (36) months (three (3) years) after the last day of the Original Term (the period set forth in this Section 1.06(b)(ii) or Section 1.06(b)(i) is referred to as the “Curtailed Return Term”).

## 1.07 Product Price.

- (a) Startup Period: During the Startup Period, the Product Price will be seventy-five percent (75%) of the Product Price for the first Term Year, as set forth in Exhibit O.
- (b) Original Term: During the Original Term, the Product Price will be as set forth in Exhibit O, for the applicable Term Year.
- (c) Curtailed Return Term: During the Curtailed Return Term, the Product Price shall be sixty-six point sixty-seven percent (66.67%) of the Product Price for the final Term Year of the Original Term, as set forth in Exhibit O.

## 1.08 Performance Assurance Amount.

On or before the Commercial Operation Date and for every Term Year during the Term, Seller shall post and maintain Performance Assurance. The Performance Assurance Amount will equal to the product of \$341.80/kW times the kilowatts of Contract Capacity.

## 1.09 Seller’s Guarantor.

(To be determined, if a Guarantor and Guaranty Agreement are accepted by SCE in accordance with this Agreement.)

- (a) Guarantor: *[Guarantor Name, if any]*
- (b) Guaranty Amount: *[Dollar amount text]* dollars (\$*[Number]*)
- (c) Cross Default Amount: *[\$\_\_\_\_\_, if any]*

## 1.10 Compliance Expenditure Cap and Curtailment Cap.

### (a) Compliance Expenditure Cap.

The Compliance Expenditure Cap will be two hundred fifty thousand dollars (\$250,000.00) within any three (3) year rolling period during the Term, with a cumulative maximum of one million dollars (\$1,000,000.00) for the Term.

If Seller reasonably anticipates the need to incur out of pocket expenses in excess of the Compliance Expenditure Cap in order to comply with the obligations to which the Compliance Expenditure Cap applies (the “Compliance Actions”), then:

- (i) Seller shall provide Notice to SCE as soon as reasonably possible of such anticipated costs; and
- (ii) SCE shall have the right, in its sole discretion, to:
  - (1) Approve such expenditures; or
  - (2) Waive Seller’s obligation to take such Compliance Actions, or any part thereof.

SCE shall evaluate such Notice and respond to Seller as soon as reasonably possible, and SCE may agree to reimburse Seller for all or some portion of the costs that exceed the Compliance Expenditure Cap (such SCE-agreed upon costs, the “Accepted Compliance Costs”).

If SCE agrees to reimburse Seller for the Accepted Compliance Costs, then Seller shall take such Compliance Actions covered by the Accepted Compliance Costs as agreed upon by the Parties and SCE shall reimburse Seller for Seller’s actual costs to effect the Compliance Actions, not to exceed the Accepted Compliance Costs. Seller shall not be required to take any of the Compliance Actions (and shall not be responsible for the consequences of failing to take any such action) to the extent that the cost of such Compliance Actions exceeds the Accepted Compliance Costs.

(b) Curtailement Cap.

The Curtailement Cap will be 13,800 MWh per Term Year, subject to further modification as set forth in Sections 3.06(g).

1.11 Interconnection Queue Position.

CAISO Transition Cluster, Queue Position Number 408.

1.12 Federal Tax Credit.

Seller expects to qualify for, and will apply for, the Federal Investment Tax Credit; *provided, however*, if Seller qualifies for and is approved by the applicable Governmental Agency for a federal grant in *lieu* of investment tax credit under Section 1603, Seller shall provide Notice to SCE within five (5) Business Days of such approval.

---

\*\*\* End of ARTICLE ONE \*\*\*

## ARTICLE TWO. TERM AND CONDITIONS PRECEDENT; TERMINATION

### 2.01 Effective Date and Obligations prior to Effective Date.

- (a) Subject to 2.01(b) below, this Agreement becomes effective on the Effective Date.
- (b) Prior to the Effective Date, each Party shall provide the other with the following:
  - (i) Signing authority consisting of evidence of authority, incumbency and specimen signature of each person executing this Agreement or any other document on its behalf in connection with this Agreement; and
  - (ii) Certified copies of resolutions of its Board of Directors, or of its relevant committees, showing that the Party is authorized to execute and deliver this Agreement and to perform its obligations under this Agreement.

### 2.02 Obligations Prior to Commencement of the Term.

- (a) CPUC Filing and Approval of this Agreement.

Within ninety (90) days after the Effective Date, SCE shall file with the CPUC the appropriate request for CPUC Approval. SCE shall expeditiously seek CPUC Approval, including promptly responding to any requests for information related to the request for CPUC Approval. Seller shall use commercially reasonable efforts to support SCE in obtaining CPUC Approval. SCE has no obligation to seek rehearing or to appeal a CPUC decision which fails to approve this Agreement or which contains findings required for CPUC Approval with conditions or modifications unacceptable to either Party.

- (b) Seller's Applications for Interconnection and Transmission Service Agreements.

Seller shall apply for and expeditiously seek an interconnection agreement to be filed with FERC to interconnect the Generating Facility to the Transmission Provider's electric system and any service agreement required to transmit electric energy to the Delivery Point. Seller's interconnection agreement shall reflect that the Generating Facility has Full Capacity Deliverability Status.

As of the Effective Date until this Agreement terminates, Seller must not withdraw the Interconnection Queue Position identified in Section 1.11 or assign or transfer that Interconnection Queue Position to any entity or for the benefit of any power purchase and sale agreement other than this Agreement without SCE's prior written consent.

- (c) Seller's Regulatory and Governmental Filings.
- (i) Within one hundred eighty (180) days after the Effective Date, Seller shall file an application or other appropriate request for CEC Pre-Certification for the Generating Facility.
  - (ii) Within one hundred twenty (120) days after the Effective Date, Seller shall file all applications or other appropriate requests with the proper authorities for Construction Permits.
  - (iii) Seller shall expeditiously seek CEC Pre-Certification and all Material Permits, including promptly responding to any requests for information from the requesting authority.
  - (iv) Within thirty (30) days after the Commercial Operation Date, Seller shall file an application or other appropriate request with the CEC for CEC Certification for the Generating Facility.
  - (v) Subject to Sections 10.02(b), 10.02(c), and 10.02(d), Seller shall expeditiously seek CEC Certification and maintain CEC Verification, including promptly responding to any requests for information from the requesting authority.

2.03 Conditions Precedent to Commencement of Term.

(a) Commencement of Term.

The Term commences upon the Commercial Operation Date.

(b) Commercial Operation Date.

- (i) Subject to the remainder of this subsection (b), the "Commercial Operation Date" shall be a date selected by Seller upon at least three (3) Business Days Notice to SCE.
- (ii) The Commercial Operation Date may not occur until each of the following has been satisfied:
  - (1) Seller has completed the installation and testing of the Generating Facility for purposes of financing, Permits, the interconnection agreement, operating agreements, the EPC agreement and manufacturer's warranties;
  - (2) Seller has received an independent engineer's certification that the Generating Facility has been completed in all material respects (except punch list items that do not materially and adversely affect the ability of the Generating Facility to operate as intended);
  - (3) Seller is prepared to perform (and to continue to perform) its energy delivery and related obligations in accordance with the requirements hereof;

*The contents of this document are subject to restrictions on disclosure as set forth herein.*

- (4) Within sixty days prior to the Commercial Operation Date, Seller has obtained Full Capacity Deliverability Status; and
  - (5) Seller has met all conditions set forth in Section 3.12(c).
- (iii) In addition, on or before the Commercial Operation Date:
- (1) Seller shall have obtained Material Permits as set forth in Section 2.02(c)(iii);
  - (2) Seller shall have posted with SCE the Performance Assurance required under Section 8.02 calculated in accordance with Section 1.08;
  - (3) The Generating Facility must be fully installed;
  - (4) The Generating Facility must be Operating in parallel with the applicable Transmission Provider's electric system;
  - (5) Seller shall be Forecasting in accordance with Exhibit D; and
  - (6) Seller shall be delivering electric energy to SCE at the Delivery Point.

#### 2.04 Termination Rights.

(a) Termination Rights of the Parties.

If either Party exercises a termination right as set forth in this Section 2.04(a) or Section 5.05, a Termination Payment will be calculated in accordance with Section 6.03, the Forward Settlement Amount will be zero dollars (\$0), the terminating Party will be considered the Non-Defaulting Party and, if the termination occurs before the commencement of the Term, Seller will be entitled to a return of any Development Security provided to SCE.

(i) Termination Rights of Both Parties.

Either Party has the right to terminate this Agreement on Notice, which will be effective five (5) Business Days after such Notice is given, if:

- (1) CPUC Approval has not been obtained or waived by SCE in its sole discretion within three hundred sixty-five (365) days after SCE files its request for CPUC Approval and a Notice of termination is given on or before the three hundred ninety-fifth (395th) day after SCE files the request for CPUC Approval.
- (2) CEC Pre-Certification has not been obtained by Seller within twelve (12) months after the Effective Date and a Notice of termination is given on or before the end of the thirteenth (13th) month after the Effective Date.

(ii) Termination for Failure to Obtain Permit Approval of Construction Permits.

- (1) If Seller has timely taken all applicable steps, but, through no action or failure to act on its part, has not been able to obtain Permit Approval of the Construction Permits by November 1, 2013, then at any time between November 2, 2013 and November 30, 2013, Seller may provide SCE with Notice of termination of this Agreement, which will be effective five (5) Business Days after the Notice is given.
- (2) If Seller has not obtained Permit Approval of the Construction Permits by December 1, 2013, and does not provide SCE with Notice of termination in accordance with Section 2.04(a)(ii)(1), SCE may, at any time between December 2, 2013 and December 31, 2013, provide Seller with Notice of termination of this Agreement. Seller shall have twenty (20) days after the date of this Notice to establish, to SCE's reasonable satisfaction, that Seller will obtain Permit Approval of the Construction Permits in sufficient time to enable it to meet the Commercial Operation Deadline; if Seller is unable to make such demonstration, the Notice will be effective twenty-five (25) days after it is given.

(iii) Termination Rights of Seller.

Seller has the right to terminate this Agreement on Notice, which will be effective five (5) Business Days after such Notice is given to SCE, if the Federal Tax Credit Legislation applicable to Seller is not enacted on or before January 1, 2018, and concurrently an event of Force Majeure validly claimed by Seller in accordance with Sections 5.02 and 5.03 is reasonably anticipated by Seller to extend the Commercial Operation Date beyond April 30, 2018 and Seller provides reasonable evidence to SCE of the need for such an extension, and such Notice and reasonable evidence are given to SCE by Seller not later than January 31, 2018.

(b) Uncured Defaults.

Upon the occurrence of an Event of Default, the Non-Defaulting Party may terminate this Agreement as set forth in Section 6.02.

(c) End of Term.

This Agreement automatically terminates at the end of the Term as set forth in Section 1.06 unless earlier terminated as provided in this Agreement.



2.05 [Intentionally Omitted.]

2.06 Rights and Obligations Surviving Termination.

(a) Survival of Rights and Obligations Generally.

The rights and obligations that are intended to survive a termination of this Agreement are all of those rights and obligations that this Agreement expressly provides survive any such termination and those that arise from Seller's or SCE's covenants, agreements, representations, and warranties applicable to, or to be performed, at or during any time before or as a result of the termination of this Agreement, including:

- (i) [Intentionally Omitted.]
- (ii) The obligation of Seller to pay the Product Replacement Damage Amount as set forth in Section 3.07(b);
- (iii) The obligation to make, or the right to receive, a Termination Payment as set forth in Section 6.03;
- (iv) The indemnity obligations as set forth in Section 10.03;
- (v) The obligation of confidentiality as set forth in Section 10.10;
- (vi) The right to pursue remedies as set forth in Sections 6.02 and 12.04;
- (vii) The limitation of liabilities as set forth in Article Seven;
- (viii) A Party's obligation or right, as applicable:
  - (1) To make or receive payment, as applicable, for CAISO Revenues and make payment for CAISO Costs, CAISO Sanctions, and SCE Penalties, as applicable, during the Startup Period and the Term as set forth in Article Four, Exhibits E and Q; and
  - (2) To make or receive Product Payments as set forth in Exhibit E;
- (ix) The covenants and indemnifications regarding the limitations on Seller's and Seller's Affiliates' ability to offer, make or agree to third party sales as set forth in Sections 2.06(b) and 3.06(i), if applicable; and
- (x) The obligation of Seller to post Performance Assurance as set forth in Section 8.02.

(b) Limitations on Seller's and Seller's Affiliates' Ability to Make or Agree to Third Party Sales from the Generating Facility after Certain Terminations of this Agreement.

If Seller terminates this Agreement, as provided in Section 2.04(a) or Section 5.05 (based on a Force Majeure as to which Seller is the Claiming

Party), or if SCE terminates this Agreement as provided in Section 3.06(d) or as a result of an Event of Default by Seller occurring prior to the Commercial Operation Deadline, neither Seller nor Seller's Affiliates may sell, or enter into a contract to sell, electric energy, Green Attributes, Capacity Attributes, or Resource Adequacy Benefits, generated by, associated with or attributable to a generating facility installed at the Site to a party other than SCE for a period of two (2) years following the effective date of such termination (the "Restricted Period").

This prohibition on contracting and sale will not apply if, before entering into such contract or making a sale to a party other than SCE, Seller or Seller's Affiliate provides SCE with a written offer to sell the electric energy, Green Attributes, Capacity Attributes and Resource Adequacy Benefits to SCE:

- (i) at the Product Price and on other terms and conditions materially similar to the terms and conditions contained in this Agreement and SCE fails to accept such offer within forty-five (45) days after SCE's receipt thereof; or
- (ii) If Seller is ineligible for the Federal Investment Tax Credit selected under Section 1.12 solely because Seller terminates this Agreement as provided in Section 2.04(a)(i)(2) (CEC Pre-Certification), Section 2.04(a)(ii) (Permit Approval) or Section 5.05 (based on a Force Majeure as to which Seller is the Claiming Party), or solely because SCE terminates this Agreement as provided in Section 3.06(d), on terms and conditions materially similar to the terms and conditions contained in this Agreement, except that the Product Price may be adjusted to account for the loss or reduction of the Federal Investment Tax Credit; *provided*, Seller must provide documentation establishing to SCE's reasonable satisfaction that the adjustment corresponds directly to and is the minimum adjustment needed to address the loss or reduction of the Federal Investment Tax Credit.

Neither Seller nor Seller's Affiliates may sell or transfer the Generating Facility, or any part thereof, or land rights or interests in the Site (including the Interconnection Queue Position) during the Restricted Period so long as the limitations contained in this Section 2.06(b) apply, unless the transferee agrees to be bound by the terms set forth in this Section 2.06(b) pursuant to a written agreement reasonably approved by SCE. Upon termination of this Agreement pursuant to the Sections referenced in the first paragraph of this Section 2.06(b), Seller shall deliver a Notice of SCE's Rights in respect of the Site, in the form attached hereto as Exhibit U, that SCE may record giving notice of SCE's rights under this Section 2.06(b).

In accordance with Section 10.03(b), Seller shall indemnify and hold SCE harmless from all benefits lost and other damages sustained by SCE as a result of any breach of the covenants contained within this Section 2.06(b).

---

\*\*\* End of ARTICLE TWO \*\*\*

**ARTICLE THREE. SELLER'S OBLIGATIONS****3.01 Conveyance of Entire Output, Conveyance of Green Attributes, Capacity Attributes and Resource Adequacy Benefits.**

- (a) Metered Amounts. Seller shall dedicate and convey the *entire* Metered Amounts throughout the Delivery Term to SCE. Seller shall convey title to and risk of loss of all Metered Amounts to SCE at the Delivery Point.
- (b) Green Attributes. Seller hereby provides and conveys all Green Attributes associated with all electricity generation from the Project to Buyer as part of the Product being delivered. Seller represents and warrants that Seller holds the rights to all Green Attributes from the Project, and Seller agrees to convey and hereby conveys all such Green Attributes to Buyer as included in the delivery of the Product from the Project.
- (c) Capacity Attributes and Resource Adequacy Benefits. Seller shall dedicate and convey any and all Capacity Attributes and Resource Adequacy Benefits generated by, associated with or attributable to the Generating Facility throughout the Delivery Term to SCE and SCE shall be given sole title to all such Capacity Attributes and Resource Adequacy Benefits.
- (d) Further Action by Seller. Commencing at least six (6) months before the Initial Synchronization Date and throughout the Delivery Term, Seller shall, at its own cost, take all actions and execute all documents or instruments necessary to effectuate the use of the Green Attributes, Capacity Attributes and Resource Adequacy Benefits for SCE's sole benefit throughout the Delivery Term, which actions include:
  - (i) Cooperating with and encouraging the regional entity responsible for resource adequacy administration to certify or qualify the Contract Capacity for resource adequacy purposes;
  - (ii) Testing the Generating Facility in order to certify the Generating Facility for resource adequacy purposes;
  - (iii) Complying with all current and future CAISO Tariff provisions that address resource adequacy and are applicable to the Generating Facility, including provisions regarding performance obligations and penalties;
  - (iv) Complying with Applicable Laws regarding the certification and transfer of Renewable Energy Credits, including participation in WREGIS or other process recognized under Applicable Laws for the registration, transfer or ownership of Green Attributes associated with the Generating Facility. (With respect to WREGIS, Seller shall cause and allow SCE to be the "Qualified Reporting Entity" and "Account Holder" (as these two terms are defined by WREGIS) for the

*The contents of this document are subject to restrictions on disclosure as set forth herein.*

Generating Facility, and so long as Seller has taken all necessary steps to be taken on its part to cause and allow SCE to be the “Qualified Reporting Entity” and “Account Holder,” and Seller takes no actions that prevent SCE from becoming and remaining the “Qualified Reporting Entity” and “Account Holder,” SCE shall otherwise be responsible for establishing and maintaining its status as a Qualified Reporting Entity and Account Holder); and

- (v) Committing to SCE the full output of the Generating Facility.
- (e) Other Sales of Product. From the Effective Date throughout the Delivery Term, Seller shall not sell the Product (or any portion thereof) to any entity other than SCE.

### 3.02 Resource Adequacy Rulings.

Seller grants, pledges, assigns and otherwise commits to SCE the generating capacity of the Generating Facility throughout the Delivery Term in order for SCE to meet its resource adequacy obligations under any Resource Adequacy Rulings.

Seller represents, warrants and covenants to SCE that:

- (a) Seller has not used, granted, pledged, assigned or otherwise committed any portion of the generating capacity of the Generating Facility to meet the resource adequacy requirements of, or to confer Resource Adequacy Benefits on, any entity other than SCE; and
- (b) Throughout the Delivery Term, Seller will not use, grant, pledge, assign or otherwise commit any portion of the generating capacity of the Generating Facility to meet the resource adequacy requirements of, or to confer Resource Adequacy Benefits on, any entity other than SCE.

### 3.03 Maintenance as ERR.

Seller covenants that, except where there has been a change in law after the Effective Date and Seller has used commercially reasonable efforts to comply with such change in law in accordance with Sections 10.02(b), 10.02(c) and 10.02(d): (i) prior to Initial Synchronization and before commencement of the Term, the Project is qualified and pre-certified by the CEC as an Eligible Renewable Energy Resource (“ERR”) as such term is defined in Public Utilities Code Section 399.12 or Section 399.16; (ii) throughout the Term the Project is qualified and certified by the CEC as an ERR; and (iii) throughout the Delivery Term, the Project’s output delivered to Buyer qualifies under the requirements of the California Renewables Portfolio Standard.

### 3.04 Allocation of Availability Incentive Payments and Non-Availability Charges.

If the Generating Facility is subject to the terms of the Availability Standards, Non-Availability Charges, and Availability Incentive Payments as contemplated under Section 40.9 of the CAISO Tariff, any Availability Incentive Payments will be for the

benefit of Seller and for Seller's account and any Non-Availability Charges will be the responsibility of Seller and for Seller's account.

3.05 Permits, Interconnection and Transmission Service Agreements, and CAISO Tariff Compliance.

- (a) Seller shall obtain and maintain throughout the Delivery Term any and all interconnection and transmission service rights and Permits required to effect delivery of the electric energy from the Generating Facility to the Delivery Point.
- (b) Seller shall be responsible for all costs and charges directly caused by, associated with, or allocated to the interconnection of the Generating Facility to the Transmission Provider's electric system and transmission of electric energy from the Generating Facility to the Transmission Provider's electric system.
- (c) Seller shall comply with the CAISO Tariff, including securing and maintaining in full force all required CAISO agreements, certifications and approvals.
- (d) Seller shall secure through the CAISO the CAISO Resource ID that is to be used solely for this Generating Facility.

3.06 Development Security.

(a) Amount.

Seller shall post and thereafter maintain a development fee ("Development Security") equal to thirty dollars (\$30) for each kilowatt of Contract Capacity.

(b) Posting Requirements.

Seller shall post the Development Security in accordance with the following terms and conditions:

- (i) Seller shall post one-half of the Development Security within thirty (30) days following the Effective Date, with the remainder to be posted within thirty (30) days after CPUC Approval is obtained or waived by SCE in its sole discretion;
- (ii) The Development Security shall be held by SCE as security for Seller's meeting the Commercial Operation Deadline and installing and demonstrating the Contract Capacity by the Firm Operation Date;
- (iii) The Development Security must be in the form of either a cash deposit or a Letter of Credit;
- (iv) If Seller posts any Development Security in cash, Seller will receive Simple Interest Payments in accordance with the procedure specified in Section 4.07 of this Agreement;

*The contents of this document are subject to restrictions on disclosure as set forth herein.*

- (v) If Seller establishes the Development Security by means of a Letter of Credit, such Letter of Credit must be provided substantially in the form of Exhibit N and shall be subject to all of the requirements set forth in Section 8.02(b); and
  - (vi) So long as there is no Event of Default, or Potential Event of Default, with respect to Seller, then upon thirty (30) days advance written Notice to SCE Seller may substitute Development Security with a replacement Letter of Credit, or cash, or any combination of the two, subject to SCE's prior reasonable approval, *provided, however*, that any replacement Development Security must meet all the requirements of Development Security under this Agreement.
- (c) Daily Delay Liquidated Damages to Extend Commercial Operation Deadline.

Seller may extend the Commercial Operation Deadline by paying to SCE damages in an amount equal to one percent (1%) of the Development Security per day for each day (or portion thereof) from and including the Commercial Operation Deadline to and excluding the Commercial Operation Date ("Daily Delay Liquidated Damages").

To extend the Commercial Operation Deadline, Seller must, at the earliest possible time, but no later than 6 a.m. on the first day of the proposed Commercial Operation Deadline extension, provide SCE with Notice of Seller's election to extend the Commercial Operation Deadline along with Seller's estimate of the duration of the extension and its payment of Daily Delay Liquidated Damages for the full estimated Commercial Operation Deadline extension period.

Seller may further extend the Commercial Operation Deadline beyond the original Commercial Operation Deadline extension period subject to the same terms applicable to the original Commercial Operation Deadline extension.

The Daily Delay Liquidated Damages payments applicable to days included in any Commercial Operation Deadline extension are nonrefundable and are in addition to, and not a part of, the Development Security.

Seller will be entitled to a refund (without interest) of any estimated Daily Delay Liquidated Damages payments paid by Seller which exceed the amount required to cover the number of days by which the Commercial Operation Deadline was actually extended.

In no event may Seller extend the Commercial Operation Deadline for more than a total of two hundred (200) days by the payment of Daily Delay Liquidated Damages.

(d) Failure to Meet Commercial Operation Deadline; Milestone Amount.

- (i) Subject to Seller's right to extend the Commercial Operation Deadline as provided in Section 3.06(c), Section 1.04, and Section 5.03 (for Force Majeure where Seller is the Claiming Party), if the Commercial Operation Date does not occur on or before the Commercial Operation Deadline, or Seller and SCE mutually agree in writing that the Commercial Operation Date will not occur on or before the Commercial Operation Deadline, or if this Agreement is terminated due to an Event of Default by Seller occurring prior to the Commercial Operation Deadline, then SCE shall be entitled to:
- (A) Retain the entire Development Security and Milestone Amount (if any), including the right to draw on and retain for SCE's sole benefit any Letter of Credit and the proceeds thereof, as well as any cash, posted as Development Security; and
- (B) Terminate this Agreement (if not already terminated by SCE as a result of the Event of Default by Seller).

If this Agreement is terminated under this Section 3.06(d)(i) or due to an Event of Default by Seller occurring prior to the Commercial Operation Deadline, the Development Security required under this Agreement and the Milestone Amount (if any) will constitute the amount of the Forward Settlement Amount owed to SCE by Seller for such termination, and Seller shall remain liable for any amounts owed as of the termination date and any obligations Seller may have in accordance with Section 2.06(a).

In addition, subject to Section 2.06(b), neither Party shall have liability for damages for failure to deliver or purchase Product after the effective date of termination under this Section 3.06(d).

- (ii) If Seller fails to meet any of the following Milestone Schedule deadlines (after the application of any extension of the Commercial Operation Date in accordance with Sections 1.04(a) or 1.04(b)): (1) groundbreaking for the Generating Facility does not occur within four (4) calendar months after the applicable date set forth in the Milestone Schedule; (2) the procurement of arrays for the Generating Facility does not occur within six (6) calendar months after the applicable date set forth in the Milestone Schedule; or (3) close of construction financing for the Generating Facility is not completed within five (5) calendar months after the applicable date set forth in the Milestone Schedule,

*then* SCE shall be entitled to draw on any Letter of Credit and retain



for its sole benefit, such proceeds or any other cash posted by Seller, in an amount equal to fifty percent (50%) of the Development Security (such fifty percent of the Development Security, the “Milestone Amount”); *provided, however*, SCE shall be entitled to only one such draw for the Milestone Amount regardless of whether Seller fails to meet one of the aforementioned Milestone Schedule deadlines or two or more of the aforementioned Milestone Schedule deadlines.

If SCE draws against any Letter of Credit or retains any posted cash pursuant to this Section 3.06(d)(ii), Seller shall replenish the Letter of Credit or cash collateral to the full Development Security amount as set forth in Section 3.06(a) within three (3) Business Days after such draw or retention; *provided*, SCE shall retain the full Milestone Amount, in addition to the full Development Security amount, if Seller fails to meet the Commercial Operation Deadline in accordance with Section 1.04 and Section 3.06(d)(i); *provided, however*, Seller shall be entitled to the return of the full Milestone Amount (in addition to any portion of the Development Security that may otherwise be returned to Seller as provided in this Section 3.06) in accordance with Exhibit L if Seller meets the Commercial Operation Deadline in accordance with Section 1.04.

(e) Full Return of Development Security.

The Development Security and Milestone Amount (if any) will be returned to Seller in accordance with the procedure set forth in Exhibit L in each of the following circumstances:

- (i) Subject to the Commercial Operation Date occurring on or before the Commercial Operation Deadline or any extended Commercial Operation Deadline as provided in this Agreement, if Seller demonstrates the full Contract Capacity in accordance with the procedure set forth in Exhibit L on or before the Firm Operation Date; or
- (ii) If this Agreement is terminated in accordance with Sections 2.04(a) or 5.05; *provided*, that a termination under Section 5.05 only entitles Seller to a return of the Development Security and Milestone Amount (if any) if the termination is based on a Force Majeure that prevents the Commercial Operation Date from occurring on or before the Commercial Operation Deadline or prevents Seller from demonstrating full Contract Capacity by the Firm Operation Date.

(f) Partial Return of the Development Security.

If the Commercial Operation Date occurs on or before the Commercial Operation Deadline, but Seller is only able to demonstrate a portion of the Contract Capacity (as may have been adjusted in accordance with

*The contents of this document are subject to restrictions on disclosure as set forth herein.*

Section 1.01(h)(1) if applicable) in accordance with the procedure set forth in Exhibit L by the Firm Operation Date, then Seller will be entitled to a return of (i) only a portion of the Development Security equal to the product of thirty dollars (\$30) per kilowatt times the kilowatts of Demonstrated Contract Capacity plus (ii) the Milestone Amount (if any).

(g) Modification of Special Conditions.

As of the Firm Operation Date:

- (i) If the Contract Capacity, as adjusted pursuant to Section 1.01(h)(1), if applicable, is greater than the Demonstrated Contract Capacity,
  - (1) The Contract Capacity will be reduced to an amount equal to the Demonstrated Contract Capacity;
  - (2) The Curtailment Cap will be recalculated by multiplying the adjusted Contract Capacity by fifty (50) hours per Term Year.
  - (3) The Expected Annual Net Energy Production will be recalculated using the Installed DC Rating pursuant to the procedures in Exhibit L; and
  - (4) The Performance Assurance Amount for the Performance Assurance required to be posted and maintained pursuant to Section 8.02 will be recalculated using such adjusted Contract Capacity, and any amount of Performance Assurance in excess of that required for the adjusted Contract Capacity will be returned to Seller.
- (ii) Neither Party will have any liability for failure to purchase or deliver Product associated with or attributable to capacity in excess of the Demonstrated Contract Capacity (“Unincluded Capacity”), subject to Section 3.06(i).

(h) Partial Retention of Development Security for Reduction in Contract Capacity.

If Seller elects to exercise its rights to reduce the Contract Capacity in accordance with Section 1.01(h), then, concurrently with its Capacity Permit Reduction Notice, Seller shall provide SCE with a written request for return of Development Security in the amount equal to the product of fifteen dollars (\$15) per kilowatt times the kilowatts of Capacity Permit Reduction Quantity.

Upon SCE’s receipt and acceptance of a Capacity Permit Reduction Notice in accordance with Section 1.01(h)(iii):

- (i) SCE shall retain for its sole benefit, free from any claim or right of any nature whatsoever of Seller, including any equity or right of purchase or redemption by Seller, the quantity of Development Security that is

- equal to the product of fifteen dollars (\$15) per kilowatt times the kilowatts of Capacity Permit Reduction Quantity (the “Permit Capacity Reduction Amount”);
- (ii) If there is no Event of Default or Potential Event of Default with respect to Seller, SCE shall return to Seller, within five (5) Business Days after the later of SCE’s receipt of the written request or its acceptance of Capacity Permit Reduction Notice, Development Security held by SCE as of the date of the Capacity Permit Reduction Notice equal to the product of fifteen dollars (\$15) per kilowatt times the kilowatts of Capacity Permit Reduction Quantity; and
  - (iii) The amount of Development Security required under this Agreement shall be recalculated with the adjusted Contract Capacity.
- (i) Restrictions on Sales Related to Unincluded Capacity, Capacity Permit Reduction Quantity and Additional Capacity.
- (i) Neither Seller nor Seller’s Affiliates may sell or enter into an agreement to sell, to a party other than SCE, from any generating facility installed at the Site, electric energy, Green Attributes, Capacity Attributes or Resource Adequacy Benefits associated with or attributable to (a) Unincluded Capacity for a period of two (2) years following SCE’s Notice to Seller of Seller’s partial forfeiture of the Development Security pursuant to Exhibit L; (b) Capacity Permit Reduction Quantity for a period of two (2) years following Capacity Permit Reduction Notice; or (c) Additional Capacity for a period of two (2) years following the Firm Operation Date.
  - (ii) With respect to Seller’s Affiliates, the prohibition on contracting and sale as set forth in Section 3.06(i)(i) will not apply if, before entering into the contract or making a sale to a party other than SCE, any Seller’s Affiliate wishing to enter into a contract or sale provides SCE with a written offer to sell the electric energy, Green Attributes, Capacity Attributes and Resource Adequacy Benefits related to Unincluded Capacity, Capacity Permit Reduction Quantity, or Additional Capacity to SCE on terms and conditions materially similar to or no less favorable to SCE than the terms and conditions contained in this Agreement and SCE fails to accept such offer within forty-five (45) days after SCE’s receipt thereof; *provided*, any Seller’s Affiliate wishing to enter into a contract or sale must:
    - (1) Build a new generating facility physically separate from the Site and Generating Facility to produce such additional electric energy and associated attributes;
    - (2) Establish an entity other than Seller to act as the seller for such additional electric energy and associated attributes;

*The contents of this document are subject to restrictions on disclosure as set forth herein.*

- (3) Meter such additional generating capacity separately from the Generating Facility, to SCE's sole satisfaction; and
- (4) Install a separate step-up transformer to interconnect such additional generating capacity to the Transmission Provider, to SCE's sole satisfaction.

If the preceding conditions are met, Seller's Affiliates (but not Seller) will be free to sell the Unincluded Capacity, Capacity Permit Reduction Quantity, or Additional Capacity, as applicable, to third parties.

### 3.07 Seller's Energy Delivery Obligation.

On the commencement of the first Term Year and for every Term Year thereafter, Seller is subject to the electric energy delivery requirements and damages for failure to perform as set forth in this Section 3.07, *provided, however*, the performance obligations of this Section 3.07 shall not apply to the final Term Year of the Curtailment Return Term if Seller fulfills its return obligation (*i.e.*, supplies three (3) times the Banked Curtailed Energy) before the end of the final Term Year of the Curtailed Return Term.

#### (a) Performance Requirements.

##### (i) Seller's Energy Delivery Obligation.

Seller's Energy Delivery Obligation for the applicable Calculation Period equals eighty five percent (85%) of the sum of the Expected Annual Net Energy Production for the Term Years in the applicable Calculation Period.

##### (ii) Event of Deficient Energy Deliveries.

At the end of each Term Year commencing with the end of the second Term Year, if the sum of the Qualified Amounts plus any Lost Output (calculated in accordance with Exhibit M) in the applicable Calculation Period does not equal or exceed Seller's Energy Delivery Obligation, then an Event of Deficient Energy Deliveries will be deemed to have occurred.

#### (b) Product Replacement Damage Amount.

- (i) If an Event of Deficient Energy Deliveries occurs, as determined in accordance with Section 3.07(a)(ii) above, the Parties acknowledge that the damages sustained by SCE associated with Seller's failure to meet Seller's Energy Delivery Obligation would be difficult or impossible to determine, or that obtaining an adequate remedy would be unreasonably time consuming or expensive, and therefore agree that Seller shall pay SCE as liquidated damages an amount which is intended to compensate SCE for Seller's failure to perform,

irrespective of whether SCE actually purchased such replacement electric energy by reason of Seller's failure to perform (the "Product Replacement Damage Amount").

- (ii) Within ninety (90) days after the end of the applicable Term Year, SCE shall calculate any Product Replacement Damage Amount as set forth in Exhibit F, and shall provide Notice to Seller of any Product Replacement Damage Amount owing, including a detailed explanation of, and rationale for, its calculation methodology, annotated work papers and source data.
  - (iii) Seller shall have thirty (30) days after receipt of SCE's Notice to review SCE's calculation and either pay the entire Product Replacement Damage Amount claimed by SCE or pay any undisputed portion and provide Notice to SCE of the portion Seller disputes along with a detailed explanation of, and rationale for, Seller's calculation methodology, annotated work papers and source data.
  - (iv) The Parties shall negotiate in good faith to resolve any disputed portion of the Product Replacement Damage Amount and shall, as part of such good faith negotiations, promptly provide information or data relevant to the dispute as each Party may possess which is requested by the other Party.
  - (v) If the Parties are unable to resolve a dispute regarding any Product Replacement Damage Amount within thirty (30) days after the sending of a Notice of dispute by Seller, either Party may submit the dispute to mediation and arbitration as provided in Article Twelve.
- (c) Continuing Obligations of Seller.

Notwithstanding any payment of a Product Replacement Damage Amount, all of Seller's obligations under Sections 3.01 and 3.02 continue to apply.

3.08 Metering, Communications, Telemetry and Meteorological Station(s).

- (a) CAISO Approved Meter.

Seller shall, at its own cost, install, maintain and test all CAISO Approved Meters pursuant to the CAISO Tariff.

- (b) Check Meter.

Seller will permit SCE to furnish and install one Check Meter on the high voltage side of the step-up transformer, substation, or any other location associated with the Generating Facility, in compliance with the applicable load serving entity and electric service provider electric service requirements. Each Check Meter must be interconnected with SCE's communication network to permit:

- (i) Periodic, remote collection of revenue quality meter data; and
  - (ii) Back-up real time transmission of operating-quality meter data.
- (c) SCE's Access to Meters.
- (i) Subject to Section 3.19, Seller hereby grants SCE reasonable access to all CAISO Approved Meters and Check Meters for meter readings and any purpose necessary to effectuate this Agreement.
  - (ii) Seller shall promptly provide SCE access to all meter data and data acquisition services both in real-time, and at later times, as SCE may reasonably request.
  - (iii) Prior to Initial Synchronization, Seller shall provide instructions to the CAISO granting authorizations or other documentation sufficient to provide SCE with access to the CAISO Approved Meter and to Seller's settlement data on OMAR.
- (d) CAISO Approved Meter Maintenance.
- (i) Seller shall test and calibrate the CAISO Approved Meter, as necessary, but in no event will the period between testing and calibration dates be greater than twelve (12) months.
  - (ii) Seller shall bear its own costs for any meter check or recertification of the CAISO Approved Meter.
  - (iii) Seller shall replace the CAISO Approved Meter battery at least once every thirty-six (36) months or such shorter period as may be recommended by the battery manufacturer.  
  
Notwithstanding the foregoing, if the CAISO Approved Meter battery fails, Seller shall replace such battery within two (2) days after becoming aware of its failure.
  - (iv) Seller shall use certified test and calibration technicians to perform any work associated with the CAISO Approved Meter.
  - (v) Seller shall inform SCE of test and calibration dates, provide SCE with access to observe and witness such testing and calibration, and provide SCE certified results of tests and calibrations within thirty (30) days after completion.
- (e) SCADA and Telemetry System.

All communication, metering, telemetry, and associated generation operation equipment will be centralized into the Generating Facility's SCADA. Seller shall configure the SCADA so that SCE may access it via the GMS from the GOC. Seller shall link the systems via an approved SCE communication network, utilizing existing industry standard network protocol, as approved by SCE. The connection will be bidirectional in nature and used by the Parties to

*The contents of this document are subject to restrictions on disclosure as set forth herein.*

exchange all data points to and from the GOC. Seller shall be responsible for the costs of installing, configuring, maintaining and operating the SCADA and internal site links for the Generating Facility.

Seller shall be responsible for designing, furnishing, installing, operating, maintaining and testing a real time Telemetry System capable of interconnecting the GMS, the CAISO-Approved Meter(s) and the Generating Facility's control system with the CAISO's Energy Communication Network.

The Telemetry System shall be designed in accordance with the CAISO monitoring and communication requirements and must be capable of:

- (i) Reporting data from each CAISO-Approved Meter;
- (ii) Providing the status of key control points from the Generating Facility's control system;
- (iii) Routing generating unit set points to the Generating Facility's control system; and
- (iv) Communicating availability of the Generating Facility pursuant to Section 3.08(g).

The Telemetry System must include a data processing gateway, internet connection, interconnecting cabling and all service agreements required for accessing the CAISO's Energy Communications Network.

The above mentioned connections and data transfer must be included in the systems engineering tasks as a part of the construction of the Generating Facility, and must be fully functional sixty (60) days before Initial Synchronization.

(f) Meteorological Station(s) and Reporting Requirements.

Seller, at its own expense, shall install and maintain one (1) or more stand-alone meteorological stations at the Generating Facility in accordance with Exhibit T to monitor and report weather data to both the CAISO and the existing SCE weather station data collection system.

The station(s) must be installed at least sixty (60) days before Initial Synchronization.

The station(s) must be equipped with the Meteorological Equipment, as may be modified by Seller at SCE's direction from time to time to reflect the CAISO's PIRP protocol and the requirements of Exhibit M.

The station(s) must be designed to collect and record data in accordance with CAISO's PIRP protocols and the requirements of Exhibit M.

Data reports must be formatted in a manner consistent with the CAISO requirements published on the CAISO internet website.

Telemetry equipment must be designed to function in accordance with CAISO's PIRP protocols.

The station(s) must be equipped to measure and record the minimum data required by the CAISO, in the manner specified by the CAISO.

Seller shall submit to SCE for review and approval as to compatibility with SCE's weather collection system, Seller's technical specifications for the meteorological station(s) in conjunction with the site plan showing the location of the station(s), Photovoltaic Modules, Current Inverters, and other prominent features, as applicable. If Seller makes a change to the Site Plan or the Generating Facility that may impact the location or required specifications for the meteorological station(s), Seller must re-submit Seller's technical specifications for the meteorological station(s) for SCE's review and approval, and SCE shall have ten (10) Business Days to approve such change in specifications in writing.

(g) Real-Time Communication of Availability.

- (i) Sixty (60) days prior to Initial Synchronization, Seller shall install a telecommunication system and demonstrate to SCE's reasonable satisfaction that the system interfaces with the Web Client and the GMS to provide SCE with Seller's Real-Time Availability.
- (ii) Seller shall maintain the telecommunications path, the hardware, and software to provide quality data to SCE throughout the Delivery Term.
- (iii) Upon Notice from SCE, Seller shall repair or have corrected as soon as commercially reasonable, but in no event later than five (5) days of receipt of such Notice of any:
  - (1) Inoperable telecommunications path;
  - (2) Inoperable software; or
  - (3) Faulty instrumentation.
- (iv) Seller shall submit an Actual Availability Report pursuant to Section 3.24 for any month in which Seller's telecommunications system was not available or did not provide quality data for longer than twenty-four (24) continuous hours.

3.09 Site Location and Control.

- (a) This Agreement is Site specific as set forth in Section 1.01(b) and Exhibit B-1. Seller may change the Site only upon SCE's prior written consent, which consent is in SCE's sole discretion. However, Seller may change the layout of the arrays within the Site at any time up to one hundred twenty days (120) prior to Initial Synchronization, so long as within thirty (30) days of the date the layout was changed (i) Seller provides SCE with

*The contents of this document are subject to restrictions on disclosure as set forth herein.*



Notice and an updated Exhibit B-1 showing the new layout, (ii) Seller provides SCE with revised specifications as required under Sections 3.11(d); and (iii) Seller provides SCE with revised meteorological specifications as required under Section 3.08(f) and SCE provides its approval as described in Section 3.08(f).

- (b) Seller shall have Site Control by start of construction and throughout the Delivery Term.
- (c) Seller shall provide SCE with prompt Notice of any change in the status of Seller's Site Control.
- (d) Seller shall provide SCE with Notice of the status of its Site Control before commencing construction of the Generating Facility.

### 3.10 Change in Structure, Ownership or Financing.

Seller shall provide Notice to SCE within five (5) Business Days after an actual or pending change in the status of any of the following:

- (a) Seller's exact and complete name, form of organization and state of incorporation or organization, or address of Seller's principal place of business;
- (b) Seller's ultimate parent, including Seller's members, general partners, or joint venturers, Seller's chief executive officer or equivalent thereof, Seller's Guarantor, as applicable;
- (c) Seller's, Seller's Guarantor's or Seller's Letter of Credit issuer's Moody's, Fitch and S&P's senior unsecured debt rating or, if such entities do not have a senior unsecured debt rating, then Seller's, Seller's Guarantor's or Seller's Letter of Credit issuer's corporate credit rating or long term issuer rating, if any;
- (d) Seller's short-term, mid-term and long-term ownership structure of the Generating Facility; and
- (e) Seller's construction-period financing and Operating-period financing, including the sources of equity investments and debt financings.

No Notice provided pursuant to this Section 3.10 constitutes or substitutes for any consent required pursuant to Sections 10.04 or 10.05.

### 3.11 Design.

At no cost to SCE, Seller shall be responsible for:

- (a) Designing and constructing the Generating Facility;
- (b) Using commercially reasonable efforts to acquire all Permits;
- (c) Providing to SCE, at least thirty (30) days before the anticipated Initial Synchronization Date, the following Generating Facility information:

*The contents of this document are subject to restrictions on disclosure as set forth herein.*

- (i) Site plan drawings for the Generating Facility;
  - (ii) Electrical one-line diagrams;
  - (iii) Control and data-acquisition details and configuration documents;
  - (iv) Major electrical equipment specifications;
  - (v) General arrangement drawings;
  - (vi) Longitude and latitude of the Site;
  - (vii) Artist renderings of the Site, if any;
  - (viii) Aerial photographs of the Site, if any;
  - (ix) Photovoltaic Module specification;
  - (x) Current Inverter specifications;
  - (xi) Solar energy collection grid diagrams; and
- (d) Providing SCE advance Notice at the earliest practicable time of any proposed changes in the Generating Facility, but in no event less than thirty (30) days before the changes are to be made, which Notice must include the information set forth in Section 3.11(c), along with all specifications and drawings pertaining to any such changes and any changes to Exhibit B-1.

### 3.12 Operation and Record Keeping.

- (a) Seller shall Operate the Generating Facility in accordance with Prudent Electrical Practices.
- (b) Seller shall comply with Operating orders in compliance with the CAISO Tariff.
- (c) On or prior to Initial Synchronization:
  - (i) SCE shall have obtained or waived CPUC Approval;
  - (ii) Seller shall obtain CEC Pre-Certification;
  - (iii) Seller shall take all steps necessary to ensure that SCE becomes authorized by the CAISO to Schedule the electric energy produced by the Generating Facility with the CAISO;
  - (iv) SCE shall have been authorized by the CAISO to Schedule the electric energy produced by the Generating Facility with the CAISO;
  - (v) Seller shall demonstrate to SCE's reasonable satisfaction that Seller has executed all necessary Transmission Provider and CAISO agreements;

- (vi) Seller shall provide to SCE the LF used by the Transmission Provider in the administration of the transmission service agreement for the Generating Facility, if applicable;
  - (vii) Seller shall be Forecasting to SCE in accordance with Exhibit D;
  - (viii) Seller shall commence delivering electric energy to SCE at the Delivery Point;
  - (ix) Seller shall have complied with all of Seller's obligations required on, before or as of Initial Synchronization in accordance with Section 3.08;
  - (x) Seller shall have registered with the NERC as the Generating Facility's Generator Owner and Generator Operator if Seller is required to be a registered entity pursuant to the NERC Reliability Standards; and
  - (xi) Seller shall have furnished to SCE all insurance documents required under Section 10.11.
- (d) Seller shall keep a daily operations log for the Generating Facility that shall include the following information:
- (i) Availability of the Inverter Block Units and associated Current Inverters;
  - (ii) Circuit breaker trip operations;
  - (iii) Any significant events related to the Operation of the Generating Facility;
  - (iv) Real and reactive power and energy production;
  - (v) Changes in Operating status;
  - (vi) Protective apparatus operations;
  - (vii) Any unusual conditions found during inspections;
  - (viii) Electric energy production, fuel consumption and efficiency (if applicable); and
  - (ix) Status and settings of generator controls including automatic voltage regulator and power system stabilizer.
- Seller shall maintain complete records of the Generating Facility's plane of array insolation, other pertinent meteorological conditions and operational status of each Inverter Block Unit.
- (e) Seller shall keep a maintenance log for the Generating Facility that shall include information on maintenance (both breakdown and preventative) performed, outages, inspections, manufacturer recommended services and

replacement, electrical characteristics of the generators, control settings or adjustments of equipment and protective devices.

Seller shall maintain documentation of all procedures applicable to the testing and maintenance of the Generating Facility protective devices as necessary to comply with NERC Reliability Standards applicable to protection systems for large electric generators, if Seller is required to be a registered entity pursuant to the NERC Reliability Standards.

Such information in (d) and (e) above shall be provided or made available to SCE within twenty (20) days after any Notice.

- (f) Seller shall promptly curtail the production of the Generating Facility:
- (i) Upon Notice from SCE that Seller has been instructed by the CAISO or Transmission Provider to curtail energy deliveries;
  - (ii) Upon Notice that Seller has been given curtailment order or similar instruction in order to respond to an Emergency;
  - (iii) If no Schedule was awarded in either the Day-Ahead Market or the Real-Time Market; or
  - (iv) If SCE issues an OSGC Order or RTOSGC Order.

If, as of the last day of the Original Term, there is Banked Curtailed Energy, and SCE has provided the Curtailed Return Term Notice in accordance with Section 1.06(b), then Seller shall deliver Product to SCE at the Delivery Point throughout the Curtailed Return Term.

- (g) Information maintained pursuant to this Section 3.12 shall be kept by Seller throughout the Delivery Term and shall be provided or made available to SCE within twenty (20) days after any Notice.
- (h) Seller must be interfaced with SCE's Generation Management System and be responsive to 5-minute Dispatch Instruction and other applicable Tariff rules in order to exercise the rights set forth in Section 4.02(c).

### 3.13 Obtaining Scheduling Coordinator Services.

Seller shall comply with all applicable CAISO Tariff procedures, protocol, rules and testing as necessary for SCE to submit Bids for the electric energy produced by the Generating Facility.

- (a) Designating SCE as Scheduling Coordinator.
- (i) At least sixty (60) days prior to Initial Synchronization, Seller shall take all actions and execute and deliver to SCE all documents necessary to authorize or designate SCE as the Scheduling Coordinator throughout the Delivery Term of this Agreement.

- (ii) Throughout the Delivery Term, Seller shall not authorize or designate any other party to act as Scheduling Coordinator, nor shall Seller perform, for its own benefit, the duties of Scheduling Coordinator.

(b) Replacement of SCE as Scheduling Coordinator.

At least forty-five (45) days before the end of the Term, or as soon as practicable before the date of any termination of this Agreement before the end of the Term, Seller shall take all actions necessary to terminate the designation of SCE as Seller's Scheduling Coordinator as of hour ending 24:00 on the last day of the Term. These actions include the following:

- (i) Seller shall submit to the CAISO a designation of a new Scheduling Coordinator for Seller to replace SCE;
- (ii) Seller shall cause the newly designated Scheduling Coordinator to submit a letter to the CAISO accepting the designation; and
- (iii) Seller shall inform SCE of the last date on which SCE will be Seller's Scheduling Coordinator. SCE must consent to any date other than the last day of the Term, such consent not to be unreasonably withheld.

3.14 Installation of Generating Facility in Increments.

Seller will in good faith endeavor to install the entire Contract Capacity, and will install the Generating Facility in increments, beginning before Initial Synchronization and ending no later than the Commercial Operation Date.

During the Startup Period Seller shall provide SCE, by no later than the last Business Day of the month preceding the month of the expected Initial Synchronization Date and by no later than the last Business Day of every month thereafter, Seller's Notice of Planned Installation.

Beginning in the month following the month of the Initial Synchronization Date, no later than the third (3rd) Business Day of every month during the Startup Period, Seller shall provide SCE with a Notice of Completed Installation describing (with reference to Exhibit B-1) the proportion of the Contract Capacity installed as of the end of the immediately prior month and specifying in kilowatts the amount of Generating Facility Capacity installed.

3.15 Forecasting.

Seller shall Forecast in accordance with the provisions of Exhibit D.

Seller shall use commercially reasonable efforts to Operate the Generating Facility so that the available capacity from the Generating Facility conforms with Forecasts provided in accordance with Exhibit D.

3.16 Scheduled Outages.

- (a) Commencing at least sixty (60) days before Initial Synchronization and throughout the Delivery Term, Seller shall, no later than January 1, April 1,

*The contents of this document are subject to restrictions on disclosure as set forth herein.*

July 1 and October 1 of each year, submit to SCE, using the Web Client, Seller's schedule of proposed planned outages ("Outage Schedule") for the subsequent twenty-four month period.

- (b) Seller shall provide the following information for each proposed planned outage:
  - (i) Start date and time;
  - (ii) End date and time; and
  - (iii) Capacity online, in MW, during the planned outage.
- (c) Within twenty (20) Business Days after SCE's receipt of an Outage Schedule, SCE shall notify Seller in writing of any reasonable request for changes to the Outage Schedule, and Seller shall, consistent with Prudent Electrical Practices, accommodate SCE's requests regarding the timing of any planned outage.
- (d) Seller shall cooperate with SCE to arrange and coordinate all Outage Schedules with the CAISO.
- (e) If a condition occurs at the Generating Facility which causes Seller to revise its planned outages, Seller shall promptly provide Notice to SCE, using the Web Client, of such change (including an estimate of the length of such planned outage) as required in the CAISO Tariff after the condition causing the change becomes known to Seller.
- (f) Seller shall promptly prepare and provide to SCE upon request, using the Web Client, all reports of actual or forecasted outages that SCE may reasonably require for the purpose of enabling SCE to comply with Section 761.3 of the California Public Utilities Code or any Applicable Law mandating the reporting by investor owned utilities of expected or experienced outages by electric energy generating facilities under contract to supply electric energy.

### 3.17 Progress Reporting Toward Meeting Milestone Schedule.

Seller shall use commercially reasonable efforts to meet the Milestone Schedule and avoid or minimize any delays in meeting this schedule. Seller shall provide SCE with a written report of Seller's progress toward meeting the Milestone Schedule using the procedures set forth in Exhibit H, (i) quarterly, between the Effective Date and the date that Seller receives its Construction Permits, and monthly thereafter; or (ii) upon SCE's reasonable request.

Seller shall include in such report a list of all letters, notices, applications, approvals, authorizations, filings, permits and licenses relating to any Transmission Provider, Governmental Authority or the CAISO and shall provide any such documents as may be reasonably requested on Notice from SCE.

In addition, Seller shall advise SCE as soon as reasonably practicable of any problems or issues of which Seller is aware which may materially impact Seller's ability to meet the Milestone Schedule.

3.18 Provision of Information.

Seller shall promptly provide to SCE copies of:

- (a) All agreements with providers of distribution, transmission or interconnection services for the Generating Facility and all amendments thereto;
- (b) All applications and approvals or disapprovals relating to CEC Pre-Certification, CEC Certification, CEC Verification, any Permit, and PIRP;
- (c) All draft, preliminary, final and revised copies of reports, studies and analyses furnished by the CAISO or any Transmission Provider, and any correspondence related thereto, concerning the interconnection of the Generating Facility to the Transmission Provider's electric system or the transmission of electric energy on the Transmission Provider's electric system;
- (d) All notifications of adjustments in the LF used by the Transmission Provider in the administration of the transmission service agreement for the Generating Facility within thirty (30) days of receiving such notification from the Transmission Provider;
- (e) All Solar Resource Evaluation Reports, and any revisions thereto, for the time period beginning on the Effective Date and ending on the last day of the first Term Year;
- (f) Any reports, studies, or assessments of the Generating Facility prepared for Seller by an independent engineer;
- (g) All Generating Facility and metering information as may be requested by SCE, including the following, at least sixty (60) days before Initial Synchronization:

For each CAISO Approved Meter:

- (1) Generating Station/Unit ID;
- (2) CAISO Resource ID;
- (3) CAISO Approved Meter Device ID;
- (4) Password;
- (5) Data path (network (ECN) or modem);
- (6) If modem, phone number;
- (7) Copy of meter certification;
- (8) List of any CAISO metering exemptions (if any); and

*The contents of this document are subject to restrictions on disclosure as set forth herein.*

- (9) Description of any compensation calculations such as transformer losses and line losses.

For the Generating Facility:

- (1) Utility transmission/distribution one line diagram;
  - (2) Physical location, address or descriptive identification;
  - (3) Latitude and longitude of centroid of Generating Facility and Meteorological Equipment;
  - (4) Telephone number on site;
  - (5) Telephone number of control room;
  - (6) Telephone number for operational issues; and
  - (7) Telephone number for administrative issues.
- (h) The names of the Interconnection Point and the Delivery Point within thirty (30) days after Seller's receipt of such information from the Transmission Provider or CAISO, as applicable;
  - (i) Any updated reports, specifications, exhibits or other documentation as SCE may reasonably request in connection with a change in the Generating Facility or the Site.

### 3.19 SCE's Access Rights.

Seller hereby grants SCE the right of ingress and egress to examine the Site and Generating Facility for any purpose reasonably connected with this Agreement or the exercise of any and all rights of SCE under Applicable Law or SCE's tariff schedules and rules on file with the CPUC. SCE shall comply with all applicable safety and security rules for the Site that have been provided to it by Seller prior to the examination, in writing or in a safety or security training video, *provided*, if any of these rules conflict with SCE's internal safety policies and procedures, the Parties shall meet and confer to resolve the conflict. For purposes of this Section 3.19, a "conflict" between safety policies and procedures will only be deemed to arise where it is not possible for SCE to comply with Seller's applicable safety and security rules while also complying with SCE internal safety policies and procedures.

### 3.20 Obtaining and Maintaining CEC Certification, and CEC Verification.

Seller shall take all necessary steps, including making or supporting timely filings with the CEC, to obtain and maintain CEC Pre-Certification and, subject to Section 10.02(b), (c) and (d), CEC Certification and CEC Verification throughout the Delivery Term.



### 3.21 Notice of Cessation or Termination of Service Agreements.

Seller shall provide Notice to SCE within three (3) Business Days after termination of, or cessation of service under, any agreement necessary to deliver Product to SCE at the Delivery Point or to meter the Metered Amounts.

### 3.22 Payments and Invoicing.

Throughout the Delivery Term, Seller shall comply with its obligations set forth in Exhibit E.

### 3.23 Lost Output Report.

#### (a) Monthly Report; SCE Review.

Commencing on the Commercial Operation Date and continuing throughout the Term, Seller shall calculate Lost Output and prepare and provide to SCE a Lost Output Report by the tenth (10th) Business Day of each month in accordance with Exhibit M.

SCE will have thirty (30) days after receipt of Seller's monthly Lost Output Report to review such report.

Upon SCE's request, Seller shall promptly provide to SCE any additional data and supporting documentation necessary for SCE to audit and verify any matters in the Lost Output Report.

#### (b) Disputes of Lost Output.

If SCE disputes Seller's Lost Output calculation, SCE shall provide Notice to Seller within thirty (30) days after receipt of Seller's Lost Output Report and include SCE's calculations and other data supporting its position.

The Parties shall negotiate in good faith to resolve any dispute.

If the Parties are unable to resolve a dispute within thirty (30) days after SCE's giving the dispute Notice, either Party may submit the dispute to mediation and arbitration as provided in Article Twelve.

Seller will have no right to claim any Lost Output for any month that was not identified in the original Lost Output Report for that month; *provided*, Seller may supplement the amount of Lost Output claimed ("Supplemental Lost Output") for the month with a supplemental Lost Output Report ("Supplemental Lost Output Report") only if Seller can demonstrate that Seller neither knew nor could have known through the exercise of reasonable diligence about the Supplemental Lost Output within the foregoing thirty (30) day period and Seller provides the Supplemental Lost Output Report within ten (10) Business Days after learning the facts which provide the basis for the Supplemental Lost Output claim.

(c) Product Replacement Damage Amount Calculation.

The Lost Output amount that will be used by SCE in the Product Replacement Damage Amount calculation set forth in Exhibit F will be the amount calculated pursuant to Exhibit M or otherwise resolved pursuant to Section 3.23(b).

3.24 Actual Availability Report.

- (a) Throughout the Delivery Term Seller shall prepare and provide to SCE a report with the Settlement Interval Actual Available Capacity of the Generating Facility (an “Actual Availability Report”) for each month.

This report must be in the form set forth in Exhibit S and must be delivered to SCE no later than the seventh (7th) Business Day following the end of the month which is the subject of the Actual Availability Report.

- (b) Upon SCE’s request, Seller shall promptly provide to SCE any additional data and supporting documentation necessary for SCE to audit and verify any matters set forth in the Actual Availability Report.

3.25 Seller’s Provision of Historic Solar Data.

- (a) Seller shall provide to SCE a minimum of one (1) year of recorded meteorological data from the Site not later than one hundred and twenty (120) days before Initial Synchronization.

Seller may provide data from additional years if any such data is available.

- (b) Data Parameters.

For each equipment station that is installed, Seller shall provide the following data to the extent such data has been recorded:

- (i) Total global irradiance;
- (ii) Wind direction;
- (iii) Wind speed;
- (iv) Air temperature;
- (v) Barometric pressure;
- (vi) Relative humidity;
- (vii) Elevation of the station; and
- (viii) Latitude and longitude of the station.

- (c) Format of Data.

Seller shall provide the data:

- (i) In the format to be specified by SCE; and

- (ii) In the interval in which such data was recorded.

### 3.26 NERC Electric System Reliability Standards.

Throughout the Delivery Term:

- (a) Seller shall be responsible for complying with any NERC Reliability Standards applicable to the Generating Facility, including registration with NERC as the Generator Operator for the Generating Facility or other applicable category under the NERC Reliability Standards and implementation of all applicable processes and procedures required by NERC or WECC for compliance with the NERC Reliability Standards; and
- (b) As between Seller and SCE, Seller shall be liable for all penalties assessed by NERC (through WECC or otherwise) for violations of the NERC Reliability Standards by the Generating Facility or Seller, as Generator Operator or other applicable category.

However, if Seller learns that NERC (through WECC or otherwise) is considering or intends to assess Seller with a penalty that Seller believes is attributable to SCE's actions or inactions as SC as described in the document entitled "NERC Reliability Standards - Responsibilities of the Generator Operator, Scheduling Coordinator, CAISO, and Reliability Coordinator" on the CAISO website at <http://www.caiso.com/2776/2776e59021220.html>, under Generator Reliability Communication Protocol or other successor description or document in effect at the time of the potential assessment, Seller shall provide SCE with sufficient notice to allow SCE to take part in administrative processes, discussions or settlement negotiations with NERC, WECC or other entity arising from or related to the alleged violation or possible penalty. If the penalty is nonetheless assessed in spite of SCE's participation in the processes, discussions or settlement negotiations, or SCE waives its right to take part in the processes, discussion or settlement negotiations, or Seller gives SCE advance Notice of Seller's mitigation plan and Seller and SCE mutually agree that Seller, or Seller and SCE (at SCE's sole discretion), shall implement the mitigation plan, then SCE shall reimburse Seller for the penalty or the agreed upon mitigation costs to the extent that:

- (i) The sole cause of Seller's violation and the potential penalty was SCE's actions or inactions as SC as described on the CAISO website at <http://www.caiso.com/2776/2776e59021220.html>, under Generator Reliability Communication Protocol or other successor description or document in effect at the time of the violation, and Seller was not able, despite its reasonable efforts, to avoid the effect of SCE's actions or inactions as SC; and
- (ii) Seller can establish to SCE's reasonable satisfaction that the penalty was actually assessed against Seller by NERC or WECC and paid by Seller to NERC or Seller actually incurred reasonable mitigation costs consistent with the mutually agreed upon mitigation plan; and

*The contents of this document are subject to restrictions on disclosure as set forth herein.*

- (iii) If Seller seeks reimbursement for mitigation costs, such costs do not exceed the lesser of the agreed upon costs under the agreed upon mitigation plan or the possible penalty.

SCE's participation in the administrative process, discussions or settlement negotiations shall not preclude Seller from disputing any violation or penalty, whether assessed or proposed, against Seller; *provided, however*, that Seller shall be solely responsible for any incremental increase in the amount of an assessed penalty where such increase is solely the result of Seller's conduct in disputing any violation or penalty.

### 3.27 Application of Prevailing Wage.

To the extent applicable, Seller shall comply with the prevailing wage requirements of Public Utilities Code Section 399.14, subdivision (h).

---

\*\*\* *End of ARTICLE THREE* \*\*\*

**ARTICLE FOUR. SCE's OBLIGATIONS****4.01 Obligation to Pay and Invoice.**

- (a) SCE shall provide information to Seller regarding CAISO Revenues, CAISO Costs, CAISO Sanctions, and SCE Penalties and shall pay Seller, all in accordance with Exhibit E.
- (b) Throughout the Delivery Term, SCE shall purchase Product generated by the Generating Facility and delivered at the Delivery Point in accordance with this Agreement, the CAISO Tariff Protocols and Applicable Law, *provided*, subject to Section 4.02, SCE has no obligation to purchase from Seller any Product that is not or cannot be delivered to the Delivery Point as a result of any circumstance, including:
  - (i) An outage of the Generating Facility;
  - (ii) A Force Majeure under Article Five; or
  - (iii) A reduction or curtailment of deliveries in accordance with Section 3.12(f).
- (c) SCE will not be obligated to pay Seller for any Product that Seller delivers in violation of Section 3.12(f), including but not limited to any energy Seller delivers in excess of the amount specified in any OSGC Order or RTOSGC Order, and Seller shall pay all CAISO Sanctions and CAISO Costs, and SCE shall retain all CAISO Revenues, associated with such Product.

**4.02 Obligations Under MRTU or Equivalent Successor Market.**

- (a) If SCE Bids all or a portion of the Forecast-Derived Energy into the Day-Ahead Market and the CAISO awards a Schedule as a result of that Bid:
  - (i) subject to Section 4.02(a)(ii), SCE shall pay Seller for the Metered Amounts in accordance with Exhibit E; and
  - (ii) SCE shall have the right, but not the obligation, to order Seller to curtail the delivery of energy (an "Over-Schedule Generation Curtailment Order" or "OSGC Order") in excess of a Schedule awarded pursuant to this Section 4.02(a) (the "Over-Schedule Generation Curtailment Quantity" or "OSGC Quantity"). SCE shall pay Seller the Product Price, as adjusted by the Product Payment Allocation Factor, for the OSGC Quantity Seller would have been able to deliver but for the fact that SCE issued an OSGC Order. (The amount of energy that could have been delivered will be determined in accordance with Section 3.23 (Lost Output) and Exhibit M, "Sellers Estimate of Lost Output".) The OSGC Quantity is not Curtailed Product.

*The contents of this document are subject to restrictions on disclosure as set forth herein.*

- (b) If no Schedule is awarded for the Forecast-Derived Energy in the Day-Ahead Market, (unless a Schedule is awarded in the Real-Time Market in response to a Bid under Section 4.02(c) or Section 4.02(d)) then, so long as Seller's Actual Availability establishes that the Generating Facility would have been able to deliver but for the fact a Schedule was not awarded (or with respect to any RTOSGC Quantity):
  - (i) For any non-On-Peak hours (as set forth in Exhibit K), if the Day-Ahead Price is zero dollars (\$0) or greater than zero dollars (\$0) (a positive price), then SCE will pay Seller the Product Price, as adjusted by the Product Payment Allocation Factor, for the Curtailed Product; or
  - (ii) For any non-On-Peak hours (as set forth in Exhibit K), if the Day-Ahead Price is less than zero dollars (\$0) (a negative price), then:
    - (1) if the total amount of Curtailed Product in a Term Year is less than the Curtailment Cap, SCE shall have no payment obligation to Seller for Curtailed Product in that Term Year; or
    - (2) if the total amount of Curtailed Product in a Term Year is greater than the Curtailment Cap, SCE will pay Seller the Product Price, as adjusted by the Product Payment Allocation Factor, for the amount of Curtailed Product greater than the Curtailment Cap in that Term Year. The amount of Curtailed Product paid for by SCE under this Section 4.02(b)(ii)(2) will be included in Banked Curtailed Energy.
  - (iii) For any On-Peak hours (as set forth in Exhibit K), SCE will pay Seller the Product Price, as adjusted by the Product Payment Allocation Factor, for the amount of such Curtailed Product.
    - (1) If the Day-Ahead Price is zero dollars (\$0) or greater than zero dollars (\$0) (a positive price), the amount of Curtailed Product paid for by SCE under this Section 4.02(b)(iii) will not apply toward the Curtailment Cap, and will not be included in Banked Curtailed Energy; or
    - (2) If the Day-Ahead Price is less than zero dollars (\$0) (a negative price), the amount of Curtailed Product paid for by SCE under this Section 4.02(b)(iii) will not apply toward the Curtailment Cap, but will be included in Banked Curtailed Energy.
- (c) Seller may instruct SCE to submit a Bid in the Real-Time Market for the Unawarded Energy; *provided*,
  - (i) Seller's instructions must be submitted prior to 6:00 p.m. PPT on the day before the operating day, and

- (ii) such instructions will specify for each hour of the applicable operating day either:
  - (1) a single price in dollars per MWh for each hour, or
  - (2) that SCE shall Bid the Unawarded Energy as Price Taker.

If a Schedule is awarded by CAISO for that Bid, then Seller shall generate and deliver energy to the Delivery Point and:

- (iii) if the Real-Time Price for the energy delivered under this Section 4.02(c) is zero dollars (\$0) or greater than zero dollars (\$0) (a positive price), then SCE shall pay Seller for the Metered Amounts in accordance with Exhibit E; or
  - (iv) if the Real-Time Price for the energy delivered under this Section 4.02(c) is less than zero dollars (\$0) (a negative price), then SCE shall pay Seller for the Metered Amounts in accordance with Exhibit E and Seller shall pay any CAISO Costs associated with that negative price.
- (d) Notwithstanding an instruction from Seller pursuant to Section 4.02(c) to Bid the Unawarded Energy in the Real-Time Market, SCE shall have the right to Bid the Unawarded Energy at a price lower than the price specified by Seller pursuant to Section 4.02(c)(ii)(1). If Seller does not instruct SCE to Bid the Unawarded Energy in accordance with Section 4.02(c), then SCE may Bid all or a portion of the Unawarded Energy in the Real-Time Market. If a Bid submitted by SCE pursuant to the conditions set forth in either of the two preceding sentences is awarded a Schedule:
- (i) Seller shall generate and deliver energy to SCE at the Delivery Point. SCE shall, subject to Section 4.02(d)(ii), pay Seller for the Metered Amounts in accordance with Exhibit E, and SCE shall pay any CAISO Costs associated with the quantity of energy that was Scheduled and delivered under this Section 4.02(d); and
  - (ii) SCE shall have the right, but not the obligation, to order Seller to curtail the delivery of energy (a “Real-Time Over-Schedule Generation Curtailment Order” or “RTOSGC Order”) in excess of a Schedule awarded pursuant to this Section 4.02(d) (the “Real-Time Over-Schedule Generation Curtailment Quantity” or “RTOSGC Quantity”). The RTOSGC Quantity is Curtailed Product, and SCE shall pay Seller for such Curtailed Product as set forth in Section 4.02(b).

#### 4.03 SCE’s Check Meter.

- (a) Providing Access to Seller.

Before Initial Synchronization, SCE shall provide to Seller remote access to the Check Meter through a website as specified by SCE. SCE may change the website and protocols from time to time.

(b) Testing of Check Meter.

SCE shall test and recalibrate the Check Meter at least once every Term Year. The Check Meter will be locked or sealed, and the lock or seal will be broken, only by a SCE representative. Seller has the right to be present whenever such lock or seal is broken. SCE shall replace the Check Meter battery at least once every 36 months; *provided*, if the Check Meter battery fails, SCE shall promptly replace such battery.

(c) Use of Check Meter for Back-Up Purposes.

(i) SCE shall routinely compare the Check Meter data to the CAISO Approved Meter data after adjusting the Check Meter for any compensation introduced by the CAISO into the CAISO Approved Meter.

(ii) If the deviation between the CAISO Approved Meter data and the Check Meter data for any comparison is greater than 0.3%, SCE shall provide Notice to Seller of such deviation and the Parties will mutually arrange for a meter check or recertification of the Check Meter or CAISO Approved Meter, as applicable.

(iii) SCE will bear its own costs for any meter check or recertification of the Check Meter.

(d) Testing procedures and standards for the Check Meter will be the same as for a comparable SCE-owned revenue-grade meter. Seller has the right to have representatives present during all such tests.

4.04 Scheduling Coordinator.

Commencing on Initial Synchronization, SCE shall act as Seller's Scheduling Coordinator and carry out all duties as Scheduling Coordinator in accordance with CAISO Tariff protocols.

4.05 Termination of Scheduling Coordinator.

SCE shall submit a letter to the CAISO identifying the date on which SCE resigns as Seller's Scheduling Coordinator on the first to occur of the following:

(a) Thirty (30) days before the end of the Term; *provided*, the effective date of resignation provided by SCE to the CAISO shall be the last day of the end of the Term, so long as there is no Event of Default or Potential Event of Default with respect to Seller;

(b) The date of any Notice from Seller of suspension of its performance pursuant to Section 6.02; or

*The contents of this document are subject to restrictions on disclosure as set forth herein.*



- (c) The date of any early termination of this Agreement.

#### 4.06 Exclusive Rights to Product and Cost Responsibility.

- (a) SCE has the exclusive right, at any time or from time to time throughout the Delivery Term, to sell, assign, convey, transfer, allocate, designate, award, report or otherwise provide any and all such Green Attributes, Capacity Attributes or Resource Adequacy Benefits to third parties; *provided*, no such action constitutes a transfer of, or a release of SCE of, its obligations under this Agreement.
- (b) Subject to Seller's obligations under this Agreement, including Sections 3.01, 3.02, 3.08, 3.12 and 3.20, SCE shall be responsible for any costs arising from or directly related to SCE's accounting for or otherwise claiming Green Attributes, Capacity Attributes and Resource Adequacy Benefits.

#### 4.07 Interest Payments on Cash Deposits.

- (a) SCE shall make monthly Simple Interest Payments, calculated using the Federal Funds Effective Rate, to Seller on cash amounts posted for the:
  - (i) Development Security; and
  - (ii) Performance Assurance.
- (b) Upon receipt of a monthly invoice (provided by Seller to SCE's Manager of Credit and Collateral as set forth in Exhibit C) that sets forth the calculation of the Simple Interest Payment amount due, SCE shall make payment thereof by the third (3rd) Local Business Day of the first month after the last month to which the invoice relates so long as such date is after the day on which such invoice is received; *provided*,
  - (i) No Event of Default has occurred and is continuing with respect to Seller; and
  - (ii) No Early Termination Date for which any unsatisfied payment obligation of Seller exists, has occurred or has been designated as the result of an Event of Default by Seller.
- (c) On or after the occurrence of an Event of Default by Seller or an Early Termination Date as a result of an Event of Default by Seller, SCE will retain any such Simple Interest Payment amount as an additional Development Security amount or a Performance Assurance amount hereunder until:
  - (i) In the case of an Early Termination Date, the obligations of Seller under this Agreement have been satisfied; or
  - (ii) In the case of an Event of Default, for so long as such Event of Default is continuing.

---

\*\*\* End of ARTICLE FOUR \*\*\*

*The contents of this document are subject to restrictions on disclosure as set forth herein.*

## ARTICLE FIVE. FORCE MAJEURE

### 5.01 No Default for Force Majeure.

Neither Party will be considered to be in default in the performance of any of its obligations set forth in this Agreement (except for obligations to pay money) when and to the extent failure of performance is caused by Force Majeure.

### 5.02 Requirements Applicable to the Claiming Party.

If a Party, because of Force Majeure, is rendered wholly or partly unable to perform its obligations when due under this Agreement, that Party (the “Claiming Party”), will be excused from whatever performance is affected by the Force Majeure to the extent so affected, *provided*, the Claiming Party must have complied with (a) and (b) directly below.

In order to be excused from its performance obligations hereunder by reason of Force Majeure:

- (a) The Claiming Party must give the other Party Notice describing the particulars of the occurrence within fourteen (14) days after the earlier of:
  - (i) The initial occurrence of the claimed Force Majeure; or
  - (ii) The first day that the Claiming Party knew or should have known that the claimed Force Majeure could or was reasonably likely to, in whole or in part, delay the Claiming Party’s performance under this Agreement, cause the Claiming Party to be unable to perform its obligations, or prevent the Claiming Party from complying with or satisfying the conditions of this Agreement; and
- (b) The Claiming Party must provide timely evidence reasonably sufficient to establish that the occurrence constitutes Force Majeure as defined in this Agreement.

The suspension of the Claiming Party’s performance due to Force Majeure will be of no greater scope and of no longer duration than is required by the Force Majeure.

In addition, the Claiming Party shall use commercially reasonable and diligent efforts to remedy its inability to perform.

This Section does not require the settlement of any strike, walkout, lockout or other labor dispute on terms which, in the sole judgment of the Claiming Party, are contrary to its interest. It is understood and agreed that the settlement of strikes, walkouts, lockouts or other labor disputes will be at the sole discretion of the Claiming Party.

When the Claiming Party is able to resume performance of its obligations under this Agreement, the Claiming Party shall give the other Party prompt Notice to that effect.

## 5.03 Commercial Operation Deadline Extension.

If the Commercial Operation Date does not occur on or before the Commercial Operation Deadline as the result of a Force Majeure occurring before the Commercial Operation Deadline, then the Commercial Operation Deadline will, subject to Sections 1.04 and 5.05 and Seller's compliance with its obligations as the Claiming Party under Section 5.02, be extended on a day-for-day basis for the duration of the Force Majeure.

## 5.04 Firm Operation Date Extension.

If Force Majeure occurs at any time after commencement of the Term, but before the Firm Operation Date, which prevents Seller from demonstrating the Contract Capacity as provided in Sections 3.06(e) or 3.06(f), then the Firm Operation Date will, subject to Seller's compliance with its obligations as the Claiming Party under Sections 5.02 and 5.05, be extended on a day-for-day basis for the duration of the Force Majeure.

## 5.05 Termination.

Either Party may terminate this Agreement on Notice, which will be effective five (5) Business Days after such Notice is provided, if:

- (a) except to the extent addressed in subsections (b) and (c) below as separate events of Force Majeure, an event of Force Majeure extends for more than three hundred sixty-five (365) consecutive days which materially and adversely affects the operations of the Claiming Party; *provided, however*, if the Generating Facility suffers an event constituting a Force Majeure which materially and adversely affects the operations of the Generating Facility, and Seller has not, in SCE's reasonable opinion, been able to repair the Generating Facility within three hundred sixty-five (365) days in spite of diligent, good faith efforts, then Seller may have an additional period of time as determined by SCE in consultation with a Licensed Professional Engineer, but in no event longer than 180 days, to complete the repairs to the Generating Facility; or
- (b) the Generating Facility is destroyed or rendered inoperable by a Force Majeure caused by a catastrophic natural disaster and a Licensed Professional Engineer determines in writing that the Generating Facility cannot be repaired or replaced within an aggregate period of twenty-four (24) months after the first day of the catastrophic natural disaster;
- (c) an event of Force Majeure for which SCE is the claiming Party extends for more than six months and the Force Majeure has prevented SCE from complying with its obligations as Schedule Coordinator under this Agreement for such six (6) month period; or

*The contents of this document are subject to restrictions on disclosure as set forth herein.*

- (d) an event of Force Majeure claimed by Seller pursuant to this Article Five extends the Commercial Operation Deadline beyond April 29, 2020.

No later than forty-five (45) days after Seller provides SCE with Notice of Force Majeure pursuant to Section 5.05(a) and (b) above, Seller shall provide SCE with a list of potential Licensed Professional Engineers for SCE's review and approval.

Seller shall reimburse SCE for the cost of the Licensed Professional Engineer.

---

\*\*\* End of ARTICLE FIVE \*\*\*

## ARTICLE SIX. EVENTS OF DEFAULT; REMEDIES

### 6.01 Events of Default.

An “Event of Default” means, with respect to a Party (a “Defaulting Party”), the occurrence of any of the following:

- (a) With respect to either Party:
  - (i) Any representation or warranty made by such Party herein is false or misleading in any material respect when made or when deemed made or repeated if the representation or warranty is continuing in nature, *provided*, if:
    - (1) The misrepresentation or breach of warranty is capable of a cure, an Event of Default will be deemed to occur if the misrepresentation or breach of warranty is not remedied within five (5) Business Days after Notice; or
    - (2) The misrepresentation or breach of warranty is not capable of a cure, but the non-breaching Party’s damages resulting from the inaccuracy can reasonably be ascertained, an Event of Default will be deemed to occur if the payment of such damages is not made within ten (10) Business Days after a Notice of these damages is provided by the non-breaching Party to the breaching Party;
  - (ii) Except for an obligation to make payment when due, the failure to perform any material covenant or obligation set forth in this Agreement (except to the extent constituting a separate Event of Default specified below or to the extent excused by a Force Majeure) if this failure is not remedied within thirty (30) days after Notice of the failure, which Notice sets forth in reasonable detail the nature of the failure; *provided*, if the failure is not reasonably capable of being cured within the thirty (30) day cure period specified above, the Party will have such additional time (not exceeding an additional one hundred twenty (120) days) as is reasonably necessary to cure the failure, so long as the Party promptly commences and diligently pursues the cure;
  - (iii) A Party fails to make when due any payment required under this Agreement and this failure is not cured within five (5) Business Days after Notice of the failure;
  - (iv) A Party becomes Bankrupt; or
  - (v) A Party consolidates or amalgamates with, or merges with or into, or transfers all or substantially all of its assets to, another entity and, at the time of such consolidation, amalgamation, merger or transfer, the resulting, surviving or transferee entity fails to assume all the

*The contents of this document are subject to restrictions on disclosure as set forth herein.*

obligations of that Party under this Agreement either by operation of law or pursuant to an agreement reasonably satisfactory to the other Party;

- (b) With respect to Seller's Guarantor (each event listed below to be deemed an Event of Default with respect to Seller):
- (i) If any representation or warranty made by Guarantor in connection with this Agreement is false or misleading in any material respect when made or when deemed made or repeated if the misrepresentation or breach of warranty is continuing in nature and the misrepresentation or breach of warranty is not remedied within five (5) Business Days after Notice;
  - (ii) The failure of Guarantor to make any payment required or to perform any other material covenant or obligation in any guaranty made in connection with this Agreement and the failure is not cured within three (3) Business Days after Notice;
  - (iii) Guarantor fails to satisfy the creditworthiness and collateral requirements in Article Eight and the failure is not cured within three (3) Business Days after Notice of the failure;
  - (iv) Guarantor becomes Bankrupt;
  - (v) The failure of a Guaranty Agreement to be in full force and effect for purposes of this Agreement (other than in accordance with its terms);
  - (vi) Guarantor repudiates, disaffirms, disclaims, or rejects, in whole or in part, or challenges the validity of any Guaranty Agreement;
  - (vii) The occurrence and continuation of a default, event of default or other similar condition or event under one or more agreements or instruments, individually or collectively, relating to indebtedness for borrowed money in the aggregate amount of not less than the Cross Default Amount, which results in such indebtedness becoming, or becoming capable at such time of being declared, immediately due and payable; or
  - (viii) The occurrence and continuation of a default in making on the due date therefore one or more payments, individually or collectively, in an aggregate amount of not less than the applicable Cross Default Amount;

*provided*, Seller may cure a Guarantor default under Sections 6.01(b)(v) or (vi) by satisfying both of the following conditions:

- (A) providing SCE, within three (3) Business Days after the default, with replacement Performance Assurance acceptable to SCE and meeting

the requirements of Article Eight in the form of Letter of Credit or cash deposit; and

- (B) paying SCE, within three (3) Business Days after the earlier of Notice to Seller of the default or the date that Seller otherwise knew of the default, any outstanding amounts owed to SCE as of the date of the default.
- (c) With respect to Seller:
  - (i) Seller fails to post and maintain the Development Security pursuant to Section 3.06(a), 3.06(b) and 3.06(d)(ii);
  - (ii) Except as permitted in Sections 10.04 and 10.05, Seller does not own the Generating Facility or have control of the Generating Facility through a Lease;
  - (iii) Seller does not have Site Control in accordance with Section 3.09 and Seller has not cured this failure within sixty (60) days after the occurrence of the event which results in the failure;
  - (iv) The sum of Qualified Amounts plus Lost Output in any consecutive six (6) month period is not at least ten percent (10%) of the Expected Annual Net Energy Production, and Seller fails to demonstrate to SCE's reasonable satisfaction, within ten (10) Business Days after Notice from SCE, a legitimate reason for the failure to meet the ten percent (10%) minimum;
  - (v) Seller intentionally or knowingly Forecasts or delivers, or attempts to Forecast or deliver, at the Delivery Point for sale under this Agreement electric energy that was not in fact generated by the Generating Facility;
  - (vi) Seller installs generating capacity in excess of the Contract Capacity and attempts to sell the output of such excess capacity to SCE or any party, and this generating capacity is not removed within five (5) Business Days after Notice from SCE;
  - (vii) Seller removes from the Site equipment upon which the Contract Capacity has been based, except for the purposes of replacement, refurbishment, repair or maintenance, and the equipment is not returned within five (5) Business Days after Notice from SCE;
  - (viii) The Generating Facility consists of an ERR type(s) different than that specified in Section 1.01(g);
  - (ix) Except where there has been a change in law that would affect Seller's status as an ERR, and Seller has made commercially reasonable efforts in accordance with Sections 10.02(b) and 10.02(d) to comply with the change in law, the Generating Facility fails to qualify as an ERR;

*The contents of this document are subject to restrictions on disclosure as set forth herein.*

- (x) Except where there has been a change in law that would affect the eligibility of electric energy to qualify as renewable energy for the purposes of the RPS Legislation and Seller has made commercially reasonable efforts in accordance with Sections 10.02(c) and 10.02(d) to comply with the change in law, any electric energy from the Generating Facility and sold or to be sold to SCE hereunder fails to qualify as eligible renewable energy for purposes of the RPS Legislation;
- (xi) The Commercial Operation Date does not occur within the timeframes set forth in Section 1.04 and this failure is not cured within five (5) Business Days after Notice from SCE;
- (xii) A termination of, or cessation of service under, any agreement necessary for Seller:
  - (1) To interconnect the Generating Facility to the Transmission Provider's electric system;
  - (2) To transmit the electric energy on the Transmission Provider's electric system; or
  - (3) To comply with the CAISO Tariff;and the affected agreement is not amended, reinstated or replaced by an agreement providing comparable services, or the cessation of service under the affected agreement is not permanently ended, within 120 days after such termination of, or cessation of service under, the affected agreement.
- (xiii) Seller fails to take any actions necessary to dedicate, convey or effectuate the use of any and all Green Attributes, Capacity Attributes and Resource Adequacy Benefits for SCE's sole benefit as specified in Section 3.01, subject to Section 10.02 (with respect to Green Attributes);
- (xiv) Except for Credit and Collateral Requirements in Article Eight for which there is a separate Event of Default specified in this Section 6.01, Seller fails to satisfy the Credit and Collateral Requirements in Article Eight and the failure is not cured within five (5) Business Days after Notice of the failure;
- (xv) Except as otherwise provided in a Collateral Assignment Agreement, the occurrence and continuation of a default, event of default or other similar condition or event under one or more agreements or instruments relating to indebtedness for borrowed money ("Indebtedness Agreements"), which is not cured within the cure period, if any, provided for in the Indebtedness Agreements and which

*The contents of this document are subject to restrictions on disclosure as set forth herein.*



results in the indebtedness becoming, or becoming capable at such time of being declared, immediately due and payable;

- (xvi) The stock, equity ownership interest in Seller or assets of Seller has been pledged or assigned as collateral or otherwise to any party other than Lender; or
  - (xvii) Seller surrenders, transfers or assigns the Interconnection Queue Position without the written consent of SCE.
- (d) With respect to SCE:
- (i) SCE breaches its obligations as Scheduling Coordinator under this Agreement and the breach is not cured within ten (10) Business Days of Notice of the breach, *provided*, if in the reasonable opinion of the non-defaulting Party, the Defaulting Party cannot reasonably cure the default within ten (10) Business Days despite a diligent, good faith effort to do so, then the Defaulting Party shall have a longer cure period to be reasonably established by the non-defaulting Party in good faith, but which shall not exceed ninety (90) days.

#### 6.02 Early Termination.

If an Event of Default shall have occurred, there will be no opportunity for cure except as specified in Section 6.01 or pursuant to a Collateral Assignment Agreement agreed upon by SCE, Seller and Lender in accordance with Section 10.05.

The Party taking the default (the “Non-Defaulting Party”) has the right:

- (a) To designate by Notice, which will be effective five (5) Business Days after the Notice is given, a day, no later than twenty (20) calendar days after the Notice is effective, for the early termination of this Agreement (an “Early Termination Date”); and
- (b) To pursue all remedies available at law or in equity against the Defaulting Party (including monetary damages), except to the extent that such remedies are limited by the terms of this Agreement.

Upon the effective designation of an Early Termination Date, the Non-Defaulting Party will have the right to immediately suspend performance under this Agreement, including performance under Section 3.01(e) but excluding the obligation to post and maintain Development Security and Performance Assurance in accordance with Section 3.06 or Article Eight.

#### 6.03 Termination Payment.

As soon as practicable after an Early Termination Date is declared, the Non-Defaulting Party shall provide Notice to the Defaulting Party of the Termination Payment.

The Notice must include a written statement setting forth, in reasonable detail, the calculation of such Termination Payment including the Forward Settlement Amount, together with appropriate supporting documentation, except that, consistent with Section 3.06(d), when an Early Termination Date is declared on the basis of an Event of Default under Section 6.01(c)(xi), the Forward Settlement Amount will be limited to the Development Security and the Milestone Amount (if any).

If the Termination Payment is positive, the Defaulting Party shall pay such amount to the Non-Defaulting Party within ten (10) Business Days after the Notice is provided. If the Termination Payment is negative (*i.e.*, the Non-Defaulting Party owes the Defaulting Party more than the Defaulting Party owes the Non-Defaulting Party), then the Non-Defaulting Party shall pay such amount to the Defaulting Party within thirty (30) days after the Notice is provided.

The Parties shall negotiate in good faith to resolve any disputes regarding the calculation of the Termination Payment. Any disputes which the Parties are unable to resolve through negotiation may be submitted for resolution through mediation and arbitration as provided in Article Twelve.

---

\*\*\* End of ARTICLE SIX \*\*\*

**ARTICLE SEVEN. LIMITATIONS OF LIABILITIES**

EXCEPT AS SET FORTH HEREIN, THERE ARE NO WARRANTIES BY EITHER PARTY UNDER THIS AGREEMENT, INCLUDING ANY WARRANTY OF MERCHANTABILITY OR FITNESS FOR A PARTICULAR PURPOSE, AND ANY AND ALL IMPLIED WARRANTIES ARE DISCLAIMED. THE PARTIES CONFIRM THAT THE EXPRESS REMEDIES AND MEASURES OF DAMAGES PROVIDED IN THIS AGREEMENT SATISFY THE ESSENTIAL PURPOSES HEREOF.

FOR BREACH OF ANY PROVISION FOR WHICH AN EXPRESS REMEDY OR MEASURE OF DAMAGES IS PROVIDED, SUCH EXPRESS REMEDY OR MEASURE OF DAMAGES WILL BE THE SOLE AND EXCLUSIVE REMEDY, THE OBLIGOR'S LIABILITY WILL BE LIMITED AS SET FORTH IN SUCH PROVISION AND ALL OTHER REMEDIES OR DAMAGES AT LAW OR IN EQUITY ARE WAIVED, UNLESS THE PROVISION IN QUESTION PROVIDES THAT THE EXPRESS REMEDIES ARE IN ADDITION TO OTHER REMEDIES THAT MAY BE AVAILABLE.

SUBJECT TO SECTION 12.04, IF NO REMEDY OR MEASURE OF DAMAGES IS EXPRESSLY PROVIDED HEREIN, THE OBLIGOR'S LIABILITY WILL BE LIMITED TO DIRECT ACTUAL DAMAGES ONLY, SUCH DIRECT ACTUAL DAMAGES WILL BE THE SOLE AND EXCLUSIVE REMEDY AND ALL OTHER REMEDIES OR DAMAGES AT LAW OR IN EQUITY ARE WAIVED.

WITH RESPECT TO SELLER, DIRECT DAMAGES INCLUDE THE VALUE OF ANY FEDERAL INVESTMENT TAX CREDITS, DETERMINED ON AN AFTER-TAX BASIS, THAT ARE LOST BY SELLER DUE TO AN EVENT OF DEFAULT BY SCE WHERE SELLER PROVIDED NOTICE OF EARLY TERMINATION TO SCE IN ACCORDANCE WITH SECTION 6.02(a) AND SELLER HAS NOT BEEN ABLE TO MITIGATE THAT LOSS AFTER USE OF REASONABLE EFFORTS. WITH RESPECT TO SCE, DIRECT DAMAGES INCLUDE THE VALUE OF GREEN ATTRIBUTES, CAPACITY ATTRIBUTES, RESOURCE ADEQUACY BENEFITS AND BANKED CURTAILED ENERGY.

UNLESS EXPRESSLY PROVIDED IN THIS AGREEMENT, INCLUDING WITHOUT LIMITATION THE PROVISIONS OF SECTION 10.03 (INDEMNITY), NEITHER PARTY WILL BE LIABLE FOR CONSEQUENTIAL, INCIDENTAL, PUNITIVE, EXEMPLARY OR INDIRECT DAMAGES, LOST PROFITS OR OTHER BUSINESS INTERRUPTION DAMAGES, BY STATUTE, IN TORT OR CONTRACT, UNDER ANY INDEMNITY PROVISION OR OTHERWISE.

IT IS THE INTENT OF THE PARTIES THAT THE LIMITATIONS HEREIN IMPOSED ON REMEDIES AND THE MEASURE OF DAMAGES BE WITHOUT REGARD TO THE CAUSE OR CAUSES RELATED THERETO, INCLUDING THE NEGLIGENCE OF ANY PARTY, WHETHER SUCH NEGLIGENCE BE SOLE, JOINT OR CONCURRENT, OR ACTIVE OR PASSIVE.

TO THE EXTENT ANY DAMAGES REQUIRED TO BE PAID HEREUNDER ARE LIQUIDATED, THE PARTIES ACKNOWLEDGE THAT THE DAMAGES ARE DIFFICULT OR IMPOSSIBLE TO DETERMINE, OR OTHERWISE OBTAINING AN ADEQUATE REMEDY IS INCONVENIENT AND THE DAMAGES CALCULATED HEREUNDER CONSTITUTE A REASONABLE APPROXIMATION OF THE HARM OR LOSS.

NOTHING IN THIS ARTICLE PREVENTS, OR IS INTENDED TO PREVENT SCE FROM PROCEEDING AGAINST OR EXERCISING ITS RIGHTS WITH RESPECT TO ANY DEVELOPMENT SECURITY, OR PERFORMANCE ASSURANCE.

---

\*\*\* End of ARTICLE SEVEN \*\*\*

**ARTICLE EIGHT. CREDIT AND COLLATERAL REQUIREMENTS****8.01 Financial Information.**

- (a) If requested by one Party, the other Party shall deliver the following financial statements, which in all cases must be for the most recent accounting period and prepared in accordance with GAAP:
  - (i) Within one hundred twenty (120) days following the end of each fiscal year, a copy of its and its Guarantor's, if any, annual report containing audited consolidated financial statements (income statement, balance sheet, statement of cash flows and statement of retained earnings and all accompanying notes) for such fiscal year, setting forth in each case in comparative form the figures for the previous year; and
  - (ii) Within sixty (60) days after the end of each of its first three fiscal quarters of each fiscal year, a copy of its and its Guarantor's, if any, quarterly report containing consolidated financial statements (income statement, balance sheet, statement of cash flows and statement of retained earnings and all accompanying notes) for such fiscal quarter and the portion of the fiscal year through the end of such quarter, setting forth in each case in comparative form the figures for the previous year.
- (b) In each case, the financial statements specified in Sections 8.01(a)(i) and 8.01(a)(ii) above must be:
  - (i) Certified in accordance with all applicable laws and regulations, including all applicable SEC rules and regulations, if such Party or its Guarantor is an SEC reporting company; or
  - (ii) Certified by a Responsible Officer as being fairly stated in all material respects (subject to normal year end audit adjustments) if such Party or its Guarantor is not an SEC reporting company.
- (c) For purposes of the requirement set forth in Section 8.01(a):
  - (i) If a Party or its Guarantor's financial statements are publicly available electronically on the website of that Party, its Guarantor or the SEC, then the Party shall be deemed to have met the requirements of Section 8.01(a); and
  - (ii) Should any such financial statements not be available on a timely basis due to a delay in preparation or certification, that delay will not be an Event of Default so long as the producing party diligently pursues the preparation, certification and delivery of the statements.

## 8.02 Performance Assurance.

### (a) Posting Performance Assurance.

On or before the Commercial Operation Date, Seller shall post Performance Assurance with SCE.

The Performance Assurance Amount due to SCE by Seller will be as set forth in Section 1.08.

The Performance Assurance Amount shall be posted to SCE and maintained at all times during the Term and thereafter until such time as Seller has satisfied all monetary obligations which survive any termination of this Agreement, not to exceed one year following the end of the Term.

The Performance Assurance Amount must be either in the form of cash or Letter of Credit acceptable to SCE, *provided*, on the commencement of the Term, if Seller has posted the Development Security in the form of cash or a Letter of Credit and SCE has not either returned the Development Security to Seller or given Seller Notice, pursuant to Exhibit L, of its determination regarding the disposition of the Development Security by such date, then Seller may withhold the portion of the Performance Assurance Amount equal to the Development Security or any portion thereof held by SCE at that time until three (3) Business Days following the later of Seller's receipt or forfeiture of the Development Security or any portion thereof pursuant to Section 3.06 and Exhibit L, after which Seller shall be obligated to post the full Performance Assurance Amount.

In *lieu* of cash or a Letter of Credit, SCE may accept a Guaranty Agreement, in accordance with Section 8.02(c), from a Guarantor acceptable to SCE, to satisfy Seller's Performance Assurance obligation.

### (b) Letters of Credit.

Performance Assurance or Development Security provided in the form of a Letter of Credit must be subject to the following provisions:

- (i) Each Letter of Credit must be maintained for the benefit of SCE;
- (ii) Seller shall:
  - (1) Renew or cause the renewal of each outstanding Letter of Credit on a timely basis as provided in the relevant Letter of Credit;
  - (2) If the bank that issued an outstanding Letter of Credit has indicated its intent not to renew such Letter of Credit, provide alternative Performance Assurance or Development Security acceptable to SCE at least twenty (20) Business Days before the expiration of the outstanding Letter of Credit; and

- (3) If the bank issuing a Letter of Credit fails to honor SCE's properly documented request to draw on an outstanding Letter of Credit, provide alternative Performance Assurance or Development Security acceptable to SCE within three (3) Business Days after such refusal;
- (iii) Upon the occurrence of a Letter of Credit Default, Seller shall provide to SCE either a substitute Letter of Credit or alternative Performance Assurance or Development Security acceptable to SCE, in each case on or before the first Business Day after the occurrence thereof. Upon the occurrence of Letter of Credit Derating, Seller shall provide to SCE either a substitute Letter of Credit or alternative Performance Assurance or Development Security acceptable to SCE, in each case on or before the fifth (5th) Business Day after the occurrence of the Letter of Credit Derating;
- (iv) Upon, or at any time after, the occurrence and continuation of an Event of Default by Seller, or if an Early Termination Date has occurred or been designated as a result of an Event of Default by Seller for which there exist any unsatisfied payment obligations, then SCE may draw on any undrawn portion of any outstanding Letter of Credit upon submission to the bank issuing such Letter of Credit of one or more certificates specifying that such Event of Default or Early Termination Date has occurred and is continuing.

In addition, SCE will have the right to draw on the Letter of Credit for any of the following reasons:

- (1) The Letter of Credit will expire in fewer than twenty (20) Local Business Days and Seller has not provided SCE alternative Performance Assurance or Development Security acceptable to SCE.
- (2) The Seller or the issuer of the Letter of Credit has provided written notice to SCE of either Seller's or the issuer's intent not to renew the Letter of Credit following the present Expiration Date thereof ("Notice of Non-Renewal"), and Seller has failed to provide SCE with a replacement letter of credit satisfactory to SCE in its sole discretion within thirty (30) days following the date of the Notice of Non-Renewal.
- (3) SCE has not been paid any or all of Seller's payment obligations due and payable under the Agreement.

Cash proceeds received by SCE from drawing upon the Letter of Credit pursuant to this Section 8.02(b)(iv)(except item (3) above for payment obligations due and payable) will be deemed Performance Assurance or Development Security (as applicable) as security for

Seller's obligations to SCE and SCE will have the rights and remedies set forth in Section 8.03 with respect to such cash proceeds.

Notwithstanding SCE's receipt of cash proceeds of a drawing under the Letter of Credit, Seller shall remain liable for any:

- (1) Failure to provide or maintain sufficient Performance Assurance or Development Security (including failure to replenish a Letter of Credit to the full Performance Assurance Amount or Development Security in the event that SCE draws against the Letter of Credit for any reason other than to satisfy a Termination Payment); or
  - (2) Any amounts owing to SCE and remaining unpaid after the application of the amounts so drawn by SCE; and
  - (v) In all cases, the costs and expenses of establishing, renewing, replenishing, substituting, canceling, and increasing the amount of any and all Letters of Credit will be borne by Seller.
- (c) Guaranty Agreement.

Any Guaranty Agreement must be in the form of Exhibit I executed by the Guarantor or other party acceptable to SCE meeting the Credit Rating requirements for the Guarantor set forth immediately below. The Guarantor shall maintain a Credit Rating of at least:

- (i) "BBB-" from S&P or Fitch and "Baa3" from Moody's, if it is rated by S&P and Moody's or Fitch and Moody's; or
- (ii) "BBB-" from S&P or Fitch or "Baa3" from Moody's if it is rated by only one of S&P, Moody's or Fitch.

If at any time the Guarantor fails to maintain such Credit Ratings, Seller shall provide to SCE Performance Assurance in the form of cash or a Letter of Credit, or a replacement Guaranty Agreement from a party acceptable to SCE, within five (5) Business Days.

### 8.03 First Priority Security Interest in Cash or Cash Equivalent Collateral.

To secure its obligations under this Agreement, and until released as provided herein, Seller hereby grants to SCE a present and continuing first-priority security interest ("Security Interest") in, and lien on (and right to net against), and assignment of the Development Security, Performance Assurance, Milestone Amount (if any), any other cash collateral and cash equivalent collateral posted pursuant to Sections 3.06 and 8.02 and any and all interest thereon or proceeds resulting therefrom or from the liquidation thereof, whether now or hereafter held by, on behalf of, or for the benefit of SCE, and Seller agrees to take all action as SCE reasonably requires in order to perfect SCE's Security Interest in, and lien on (and right to net against), such collateral and any and all proceeds resulting therefrom or from the liquidation thereof.

*The contents of this document are subject to restrictions on disclosure as set forth herein.*



Upon or any time after the occurrence of, and during the continuation of, an Event of Default caused by Seller, an Early Termination Date resulting from an Event of Default caused by Seller, or an occasion provided for in this Agreement where SCE is authorized to retain all or a portion of the Performance Assurance or Development Security, SCE may do any one or more of the following:

- (a) Exercise any of its rights and remedies with respect to the Development Security, Milestone Amount and Performance Assurance, including any such rights and remedies under law then in effect;
- (b) Draw on any outstanding Letter of Credit issued for its benefit; and
- (c) Liquidate all Development Security or Performance Assurance (as applicable) then held by or for the benefit of SCE free from any claim or right of any nature whatsoever of Seller, including any equity or right of purchase or redemption by Seller.

SCE shall apply the proceeds of the collateral realized upon the exercise of any such rights or remedies to reduce Seller's obligations under this Agreement (Seller remains liable for any amounts owing to SCE after such application), subject to SCE's obligation to return any surplus proceeds remaining after these obligations are satisfied in full.

#### 8.04 Credit and Collateral Covenants.

- (a) Seller shall, from time to time as requested by SCE, execute, acknowledge, record, register, deliver and file all such notices, statements, instruments and other documents as may be necessary or advisable to render fully valid and enforceable under all Applicable Laws the rights, liens and priorities of SCE with respect to the Security Interest provided for herein and therein.
- (b) Seller may not cause or permit the stock, equity ownership interest in Seller or assets of Seller to be pledged or assigned as collateral or otherwise to any party other than Lender.
- (c) Seller may not create, incur, issue, assume, guarantee or otherwise become directly or indirectly liable for, contingently or otherwise, any Seller's Debt, or issue any Disqualified Stock, in each case, other than Seller's Debt incurred, issued, assumed or guaranteed, or Disqualified Stock issued, in connection with the funding of the development, construction or Operation of the Generating Facility.
- (d) Other than to a Lender, Seller may not create, incur, assume or suffer to be created by it or any subcontractor, employee, laborer, materialman, other supplier of goods or services or any other person, any lien on Seller's interest (or any part thereof) in this Agreement, the Site or the Generating Facility, other than a lien to secure payment that will be discharged in the normal course of constructing, operating or maintaining the Generating Facility.

*The contents of this document are subject to restrictions on disclosure as set forth herein.*

Seller will, within fifteen (15) days of notice of a lien, promptly remove (i) by paying or discharging, (ii) causing its contractors to promptly pay and discharge, and discharge of record, (iii) reaching a settlement regarding; or (iv) furnishing a release bond or deposit under Applicable Law for, any such lien for labor, materials, supplies or other obligations upon Seller's interest in the Site, the Generating Facility, or any part thereof or interest therein, unless Seller is disputing any such lien in good faith and only for so long as it does not create an imminent risk of a sale or transfer of the Generating Facility or a material part thereof.

Seller shall promptly notify SCE of any attachment or imposition of any lien against Seller's interest (or any part thereof) in the Site, the Generating Facility, or any part thereof or interest therein.

- (e) Seller may not hold any material assets, become liable for any material obligations or engage in any material business activities other than the development, construction and Operation of the Generating Facility.
- (f) Seller may not own, form or acquire, or otherwise conduct any of its activities through, any direct or indirect subsidiary.
- (g) During any period during which Seller is a Defaulting Party, Seller may not:
  - (i) Declare or pay any dividend, or make any other distribution or payment, on account of any equity interest in Seller; or
  - (ii) Otherwise make any distribution or payment to any Affiliate of Seller.

#### 8.05 Commercial Code Waiver.

This Agreement sets forth the entirety of the agreement of the Parties regarding credit, collateral and adequate assurances. Except as expressly set forth in Article Eight of this Agreement, neither Party:

- (a) Has or will have any obligation to post margin, provide letters of credit, pay deposits, make any other prepayments or provide any other financial assurances, in any form whatsoever; or
- (b) Will have reasonable grounds for insecurity with respect to the creditworthiness of a Party that is complying with the relevant provisions of Article Eight of this Agreement;

and all implied rights relating to financial assurances arising from Section 2609 of the California Commercial Code or case law applying similar doctrines, are hereby waived.

#### 8.06 Substitution of Performance Assurance.

So long as there is no Event of Default as to Seller, Performance Assurance may be substituted:

- (a) Once every two (2) years during the Term upon thirty (30) days prior written Notice to SCE; or
- (b) As part of a Change of Control (concurrently with the Change of Control when it results in a new Seller or the same Seller with a new name; otherwise, upon written Notice given within sixty (60) days of the Change of Control); or
- (c) At any time when Seller is replacing a Guaranty Agreement with a Letter of Credit or cash deposit or a combination of both Letter of Credit and cash deposit;

*Provided however*, if a Potential Event of Default has occurred, any substitution of Performance Assurance under this Section 8.06 must take place within the cure periods, if any, set forth in Section 6.01.

With respect to 8.06(a) and (b) above, Seller may replace one form of Performance Assurance with (i) another form of Performance Assurance; or (ii) a combination of both forms of Performance Assurance.

Any replacement Performance Assurance under this Section 8.06 is subject to SCE's prior approval and all requirements of this Agreement.

---

\*\*\* *End of ARTICLE EIGHT* \*\*\*

**ARTICLE NINE. GOVERNMENTAL CHARGES****9.01 Cooperation to Minimize Tax Liabilities.**

Each Party shall use reasonable efforts to implement the provisions of and to administer this Agreement in accordance with the intent of the Parties to minimize all taxes, so long as neither Party is materially adversely affected by such efforts.

**9.02 Governmental Charges.**

Seller shall pay or cause to be paid all taxes imposed by any Governmental Authority (“Governmental Charges”) on or with respect to the Metered Amounts (and any contract associated with the Metered Amounts) arising before the Delivery Point, including ad valorem taxes and other taxes attributable to the Generating Facility, land, land rights or interests in land for the Generating Facility.

SCE shall pay or cause to be paid all Governmental Charges on or with respect to the Metered Amounts at and from the Delivery Point. If Seller is required by law or regulation to remit or pay Governmental Charges which are SCE’s responsibility hereunder, SCE shall promptly reimburse Seller for such Governmental Charges.

If SCE is required by law or regulation to remit or pay Governmental Charges which are Seller’s responsibility hereunder, SCE may deduct such amounts from monthly Product Payments to Seller made pursuant to Exhibit E.

If SCE elects not to deduct such amounts from Seller’s monthly Product Payments, Seller shall promptly reimburse SCE for such amounts upon SCE’s Payment Invoice request. Nothing shall obligate or cause a Party to pay or be liable to pay any Governmental Charges for which that Party is exempt under the law.

**9.03 Providing Information to Taxing Authorities.**

Seller or SCE, as necessary, shall provide information concerning the Generating Facility to any requesting taxing authority.

---

\*\*\* End of ARTICLE NINE \*\*\*

**ARTICLE TEN. MISCELLANEOUS****10.01 Representations and Warranties.**

On the Effective Date, each Party represents and warrants to the other Party that:

- (a) It is duly organized, validly existing and in good standing under the laws of the jurisdiction of its formation;
- (b) Except for CPUC Approval in the case of SCE, and all Permits in the case of Seller, it has or will timely acquire all regulatory authorizations necessary for it to legally perform its obligations under this Agreement;
- (c) The execution, delivery and performance of this Agreement are within its powers, have been duly authorized by all necessary action and do not violate any of the terms and conditions in its governing documents, any contracts to which it is a party or any law, rule, regulation, order or the like applicable to it;
- (d) This Agreement constitutes a legally valid and binding obligation enforceable against it in accordance with its terms, subject to any Equitable Defenses;
- (e) There is not pending, or to its knowledge, threatened against it or, in the case of Seller, any of its Affiliates, any legal proceedings that could materially adversely affect its ability to perform under this Agreement;
- (f) No Event of Default with respect to it has occurred and is continuing and no such event or circumstance would occur as a result of its entering into or performing its obligations under this Agreement;
- (g) It is acting for its own account and its decision to enter into this Agreement is based upon its own judgment, not in reliance upon the advice or recommendations of the other Party and it is capable of assessing the merits of and understanding, and understands and accepts the terms, conditions and risks of this Agreement.
- (h) It has not relied upon any promises, representations, statements or information of any kind whatsoever that are not contained in this Agreement in deciding to enter into this Agreement; and
- (i) It has entered into this Agreement in connection with the conduct of its business and it has the capacity or ability to make or take delivery of the Product as contemplated in this Agreement.

**10.02 Additional Seller Representations, Warranties and Covenants.**

- (a) Seller hereby represents, warrants and covenants to SCE that throughout the Delivery Term:
  - (i) Seller shall own and Operate the Generating Facility;

*The contents of this document are subject to restrictions on disclosure as set forth herein.*

- (ii) Seller shall deliver to SCE the Product free and clear of all liens, security interests, claims and encumbrances or any interest therein or thereto by any person;
  - (iii) Seller shall hold the rights to all Green Attributes, Capacity Attributes and Resource Adequacy Benefits, which Seller has conveyed and has committed to convey to SCE hereunder;
  - (iv) Seller shall obtain, maintain and remain in compliance with all Permits, interconnection agreements and transmission rights necessary to Operate the Generating Facility and to deliver electric energy from the Generating Facility to the Delivery Point;
  - (v) Subject to Sections 10.02(b), 10.02(c) and 10.02(d), Seller shall take all actions necessary for the Project to qualify and be certified by the CEC as an ERR; and
  - (vi) Subject to Sections 10.02(b), 10.02(c) and 10.02(d), Seller shall take all actions necessary for the Product delivered to SCE to qualify under the requirements of the California Renewables Portfolio Standard.
- (b) Seller, and, if applicable, its successors, represents and warrants that throughout the Delivery Term of this Agreement that:
- (i) The Project qualifies and is certified by the CEC as an Eligible Renewable Energy Resource (“ERR”) as such term is defined in Public Utilities Code Section 399.12 or Section 399.16; and
  - (ii) The Project’s output delivered to Buyer qualifies under the requirements of the California Renewables Portfolio Standard.

To the extent a change in law occurs after execution of this Agreement that causes this representation and warranty to be materially false or misleading, it shall not be an Event of Default if Seller has used commercially reasonable efforts to comply with such change in law.

- (c) Seller and, if applicable, its successors, represents and warrants that throughout the Delivery Term of this Agreement the renewable energy credits transferred to Buyer conform to the definition and attributes required for compliance with the California Renewables Portfolio Standard, as set forth in California Public Utilities Commission Decision 08-08-028, and as may be modified by subsequent decision of the California Public Utilities Commission or by subsequent legislation. To the extent a change in law occurs after execution of this Agreement that causes this representation and warranty to be materially false or misleading, it shall not be an Event of Default if Seller has used commercially reasonable efforts to comply with such change in law.

- (d) The term “commercially reasonable efforts” as used in Section 10.02(b), 10.02(c) and Section 3.03 means efforts consistent with and subject to the Compliance Expenditure Cap.
- (e) Seller warrants that all necessary steps to allow the renewable energy credits transferred to Buyer to be tracked in the Western Renewable Energy Generation Information System will be taken prior to the first delivery under the contract.
- (f) Seller hereby represents and warrants that, as of the Effective Date, it has no knowledge of any plans by the Transmission Provider to seek to construct a transmission or distribution line through or on the Site.
- (g) Seller covenants that neither Seller nor its Affiliates shall construct another generating facility on the Site or interconnect another generating facility on the generation-tie line that will be used by the Generating Facility under this Agreement, except as permitted in Section 2.06(b) or with the written consent of SCE. If Seller becomes aware of public information that a third party has applied to interconnect, or the Transmission Provider intends to interconnect, another generating facility on the same generation-tie line as the one that will be used by the Generating Facility, Seller shall immediately direct SCE to such public information.

### 10.03 Indemnity.

(a) SCE’s Indemnification Obligations.

In addition to any other indemnification obligations SCE may have elsewhere in this Agreement, which are hereby incorporated in this Section 10.03(a), SCE releases, and shall indemnify, defend and hold harmless Seller, and Seller’s directors, officers, employees, agents, assigns, and successors in interest, from and against any and all loss, liability, damage, claim, cost, charge, demand, fine, penalty or expense of any kind or nature (including attorneys’ fees (including cost of in-house counsel) and other costs of litigation, arbitration and mediation, and in the case of third-party claims only, indirect and consequential loss or damage), arising out of or in connection with:

- (i) any breach made by SCE of its representations and warranties in Section 10.01; and
- (ii) so long as Seller has fully complied with the Generator Operator Obligations and Generator Owner Obligations, any NERC Standards Non-Compliance Penalties which are solely due to SCE’s negligence in performing its role as Seller’s Scheduling Coordinator throughout the Delivery Term, subject to limitations set forth in Section 3.26.

This indemnity applies notwithstanding Seller’s active or passive negligence. However, Seller will not be indemnified hereunder for its loss, liability,

*The contents of this document are subject to restrictions on disclosure as set forth herein.*

damage, claim, cost, charge, demand or expense to the extent caused by its gross negligence or willful misconduct.

(b) Seller's Indemnification Obligations.

In addition to any other indemnification obligations Seller may have elsewhere in this Agreement, which are hereby incorporated in this Section, Seller releases, and shall indemnify, defend and hold harmless SCE, and SCE's directors, officers, employees, agents, assigns, and successors in interest, from and against any and all loss, liability, damage, claim, cost, charge, demand, penalty, fine or expense of any kind or nature (including attorneys' fees (including cost of in-house counsel) and other costs of litigation, arbitration or mediation, and in the case of third-party claims only, including claims arising from a breach of Section 10.02(b), indirect or consequential loss or damage), arising out of or in connection with:

- (i) any breach made by Seller of its representations and warranties in Sections 10.01 and 10.02;
- (ii) Seller's failure to fulfill its obligations regarding Resource Adequacy Benefits as set forth in Sections 3.01 and 3.02;
- (iii) NERC Standards Non-Compliance Penalties or an attempt by any Governmental Authority, person or entity to assess such NERC Standards Non-Compliance Penalties against SCE, except to the extent solely due to SCE's negligence in performing its role as Seller's Scheduling Coordinator throughout the Delivery Term;
- (iv) injury or death to persons, including SCE employees, and physical damage to property, including SCE property, where the damage arises out of, is related to, or is in connection with, Seller's obligations or performance under this Agreement;
- (v) injury or death to any person or damage to any property, including the personnel or property of SCE, to the extent that SCE would have been protected had Seller complied with all of the provisions of Section 10.11; *provided*, the inclusion of this Section 10.03(b)(v) is not intended to create any express or implied right in Seller to elect not to provide the insurance required under Section 10.11;
- (vi) any breach by Seller of the covenants set forth in Section 2.06(b).

This indemnity applies notwithstanding SCE's active or passive negligence. However, SCE will not be indemnified under Section 10.03(b)(i) through Section 10.03(b)(iv) for its loss, liability, damage, claim, cost, charge, demand or expense to the extent caused by its gross negligence or willful misconduct.



(c) Mutual Indemnification.

Each Party shall indemnify, defend and hold harmless the other Party and the other Party's directors, officers, employees, and agents, assigns, and successors in interest, from and against any and all loss, liability, damage, claim, cost, charge, demand, fine, penalty or expense of any kind or nature (including direct, indirect, or consequential loss, damage, claim, cost, charge, demand, or expense, including attorneys' fees (including costs of in-house counsel) and other costs of litigation, arbitration or mediation), arising out of or in connection with a Party's failure to pay any Governmental Charges for which such Party is responsible under Article Nine.

(d) Indemnification Claims.

All claims for indemnification by a Party entitled to be indemnified under this Agreement (an "Indemnified Party") by the other Party (the "Indemnitor") will be asserted and resolved as follows:

- (1) If a claim or demand for which an Indemnified Party may claim indemnity is asserted against or sought to be collected from an Indemnified Party by a third party, the Indemnified Party shall as promptly as practicable give Notice to the Indemnitor; *provided*, failure to provide this Notice will relieve Indemnitor only to the extent that the failure actually prejudices Indemnitor.
- (2) Indemnitor will have the right to control the defense and settlement of any claims in a manner not adverse to Indemnified Party but cannot admit any liability or enter into any settlement without Indemnified Party's approval.
- (3) Indemnified Party may employ counsel at its own expense with respect to any claims or demands asserted or sought to be collected against it; *provided*, if counsel is employed due to a conflict of interest or because Indemnitor does not assume control of the defense, Indemnitor will bear the expense of this counsel.

(e) Survival of Indemnification Rights and Obligations.

All indemnity rights and obligations survive the termination of this Agreement for twelve (12) months.

10.04 Assignment.

- (a) Except as provided in Section 10.05, neither Party can assign this Agreement or its rights hereunder without the prior written consent of the other Party, which consent shall not be unreasonably withheld.
- (b) Any direct or indirect Change of Control of Seller, except to a Permitted Transferee, (whether voluntary or by operation of law) will be deemed an

assignment and will require the prior written consent of SCE, which consent shall not be unreasonably withheld.

## 10.05 Consent to Collateral Assignment.

Subject to the provisions of this Section 10.05, Seller has the right to assign this Agreement as collateral for any financing or refinancing of the Generating Facility.

In connection with any financing or refinancing of the Generating Facility by Seller, SCE shall in good faith work with Seller and Lender to enter into a consent to collateral assignment of this Agreement (“Collateral Assignment Agreement”).

The Collateral Assignment Agreement must be in form and substance agreed to by SCE, Seller and Lender, including, among others, the following provisions (or such other substantially similar provisions as agreed to in writing by and between SCE, Seller and Lender):

- (a) SCE shall give Notice of an Event of Default by Seller, to the person(s) to be specified by Lender in the Collateral Assignment Agreement, before exercising its right to terminate this Agreement as a result of such Event of Default;
- (b) Following an Event of Default by Seller under this Agreement, SCE may require Seller or Lender to provide to SCE a report concerning:
  - (i) The status of efforts by Seller or Lender to develop a plan to cure the Event of Default;
  - (ii) Impediments to the cure plan or its development;
  - (iii) If a cure plan has been adopted, the status of the cure plan’s implementation (including any modifications to the plan as well as the expected timeframe within which any cure is expected to be implemented); and
  - (iv) Any other information which SCE may reasonably require related to the development, implementation and timetable of the cure plan.

Seller or Lender must provide the report to SCE within ten (10) Business Days after Notice from SCE requesting the report. SCE will have no further right to require the report with respect to a particular Event of Default after that Event of Default has been cured;

- (c) Lender will have the right to cure an Event of Default on behalf of Seller, only if Lender sends a written notice to SCE before the end of any cure period indicating Lender’s intention to cure. Lender must remedy or cure the Event of Default within the cure period under this Agreement; *provided*, such cure period may, in SCE’s sole discretion, be extended by no more than an additional one hundred eighty (180) days;

- (d) Lender will have the right to consent before any termination of this Agreement which does not arise out of an Event of Default;
- (e) Lender will receive prior Notice of and the right to approve material amendments to this Agreement, which approval will not be unreasonably withheld, delayed or conditioned;
- (f) If Lender, directly or indirectly, takes possession of, or title to the Generating Facility (including possession by a receiver or title by foreclosure or deed in lieu of foreclosure), Lender must assume all of Seller's obligations arising under this Agreement and all related agreements (subject to such limits on liability as are mutually agreed to by Seller, SCE and Lender as set forth in the Collateral Assignment Agreement);

provided that, Lender will have no personal liability for any monetary obligations of Seller under this Agreement which are due and owing to SCE as of the assumption date; provided, however, that before such assumption, if SCE advises Lender that SCE will require that Lender cure (or cause to be cured) any Event of Default existing as of the possession date in order to avoid the exercise by SCE (in its sole discretion) of SCE's right to terminate this Agreement with respect to such Event of Default, then Lender at its option, and in its sole discretion, may elect to either:

- (i) Cause such Event of Default to be cured, or
  - (ii) Not assume this Agreement;
- (g) If Lender elects to sell or transfer the Generating Facility (after Lender directly or indirectly, takes possession of, or title to the Generating Facility), or sale of the Generating Facility occurs through the actions of Lender (for example, a foreclosure sale where a third party is the buyer, or otherwise), then Lender must cause the transferee or buyer to assume all of Seller's obligations arising under this Agreement and all related agreements as a condition of the sale or transfer.

Such sale or transfer may be made only to an entity with financial qualifications (including collateral support and any other additional security as may be required by SCE) and Operating experience meeting the requirements set forth in the definition of Permitted Transferee as determined by SCE in its sole discretion; and

- (h) If this Agreement is rejected in Seller's Bankruptcy or otherwise terminated in connection therewith and if Lender or its designee, directly or indirectly, takes possession of, or title to, the Generating Facility (including possession by a receiver or title by foreclosure or deed in lieu of foreclosure), Lender must itself or must cause its designee to promptly enter into a new agreement with SCE having substantially the same terms as this Agreement.

## 10.06 Abandonment.

Seller may not relinquish its possession and control of the Generating Facility without the prior written consent of SCE except under circumstances provided for in Sections 10.04 and 10.05.

For purposes of this Section 10.06, Seller will have been deemed to relinquish possession of the Generating Facility if, with respect to any time prior to the Commercial Operation Date, Seller has ceased work on the Generating Facility (such as design, permitting, development, construction) for a consecutive one hundred and eighty (180) day period or, with respect to any time as of and after the Commercial Operation Date, the Generating Facility has ceased production and delivery of the Product for a consecutive sixty (60) day period and such cessation is not a result of an event of Force Majeure.

## 10.07 Governing Law.

THIS AGREEMENT AND THE RIGHTS AND DUTIES OF THE PARTIES HEREUNDER SHALL BE GOVERNED BY AND CONSTRUED, ENFORCED AND PERFORMED IN ACCORDANCE WITH THE LAWS OF THE STATE OF CALIFORNIA, WITHOUT REGARD TO PRINCIPLES OF CONFLICTS OF LAW. TO THE EXTENT ENFORCEABLE AT SUCH TIME, EACH PARTY WAIVES ITS RESPECTIVE RIGHT TO ANY JURY TRIAL WITH RESPECT TO ANY LITIGATION ARISING UNDER OR IN CONNECTION WITH THIS AGREEMENT.

## 10.08 Notices.

All notices, requests, invoices, statements or payments must be made as specified in Exhibit C.

Notices (other than Forecasts, scheduling requests and curtailment (or equivalent) requests) must, unless otherwise specified herein, be in writing and may be delivered by hand delivery, first class United States mail, overnight courier service or facsimile. Notices of curtailment (or equivalent orders) may be oral or written and must be made in accordance with accepted industry practices for such notices.

Notice provided in accordance with this Section 10.08 will be deemed given as follows:

- (a) Notice by facsimile or hand delivery will be deemed given at the close of business on the day actually received, if received during business hours on a Business Day, and otherwise will be deemed given at the close of business on the next Business Day;
- (b) Notice by overnight United States mail or courier service will be deemed given on the next Business Day after such Notice was sent out;
- (c) Notice by first class United States mail will be deemed given two (2) Business Days after the postmarked date;

*The contents of this document are subject to restrictions on disclosure as set forth herein.*

- (d) Notice of curtailment will be deemed given on the date and time made by SCE and will be effective immediately.

Notices will be effective on the date deemed given, unless a different date for the Notice to go into effect is stated in another section of this Agreement.

A Party may change its designated representatives, addresses and other contact information by providing Notice of same in accordance herewith.

All Notices, requests, invoices, statements or payments for this Generating Facility must reference the RAP ID.

#### 10.09 General.

- (a) This Agreement constitutes the entire agreement between the Parties relating to its subject matter.
- (b) This Agreement will be considered for all purposes as prepared through the joint efforts of the Parties and may not be construed against one Party or the other as a result of the preparation, substitution, submission or other event of negotiation, drafting or execution hereof.
- (c) Except to the extent provided for herein, no amendment or modification to this Agreement will be enforceable unless reduced to a writing signed by all Parties.
- (d) This Agreement does not impart any rights enforceable by any third party (other than a permitted successor or assignee bound to this Agreement).
- (e) Waiver by a Party of any default by the other Party may not be construed as a waiver of any other default.
- (f) The term “including” when used in this Agreement is by way of example only and may not be considered in any way to be in limitation.
- (g) The word “or” when used in this Agreement includes the meaning “and/or” unless the context unambiguously dictates otherwise.
- (h) The headings used in this Agreement are for convenience and reference purposes only. Words having well-known technical or industry meanings have these meanings unless otherwise specifically defined in this Agreement.
- (i) Where days are not specifically designated as Business Days, they will be considered as calendar days.
- (j) This Agreement is binding on each Party’s successors and permitted assigns.
- (k) No provision of this Agreement is intended to contradict or supersede any applicable agreement covering transmission, distribution, metering, scheduling or interconnection. In the event of an apparent contradiction between this Agreement and any such agreement, the applicable agreement controls.

*The contents of this document are subject to restrictions on disclosure as set forth herein.*

- (l) Whenever this Agreement specifically refers to any law, tariff, government department or agency, regional reliability council, Transmission Provider, or credit rating agency, the Parties hereby agree that the reference also refers to any successor to such law, tariff or organization.
- (m) SCE has assigned a RAP ID number to this Agreement for tracking purposes only.
- (n) SCE's obligation to take and pay for electric energy produced by the Generating Facility, together with Green Attributes, Resource Adequacy Benefits and Capacity Attributes associated therewith, will not be affected by any change to or elimination of the RPS Legislation.
- (o) The Parties acknowledge and agree that this Agreement and the transactions contemplated by this Agreement constitute a "forward contract" within the meaning of the Bankruptcy Code and that SCE and Seller are each "forward contract merchants" within the meaning of the Bankruptcy Code.
- (p) This Agreement may be executed in one or more counterparts, each of which will be deemed to be an original of this Agreement and all of which, when taken together, will be deemed to constitute one and the same agreement. The exchange of copies of this Agreement and of signature pages by facsimile transmission, Portable Document Format (i.e., PDF) or by other electronic means constitutes effective execution and delivery of this Agreement as to the Parties and may be used in lieu of the original Agreement for all purposes.
- (q) Each Party shall act in good faith in its performance under this Agreement.
- (r) All dollar amounts set forth in this Agreement are in U.S. dollars.

## 10.10 Confidentiality.

- (a) Terms and Conditions of this Agreement.

Neither Party shall disclose Confidential Information to a third party, other than:

- (i) To such Party's employees, Lenders, counsel, accountants, advisors or investors, in each case who have a need to know such information and have agreed to keep such terms confidential;
- (ii) To potential Lenders with the consent of SCE, which consent will not be unreasonably withheld; *provided*, disclosure:
  - (1) Of cash flow, other financial projections and a brief description of other relevant material terms and conditions of this Agreement, the form and content of which shall be subject to SCE's approval in its sole discretion, to any potential Lender in connection with a potential loan or tax equity investment; or

- (2) Of Confidential Information to potential Lenders with whom Seller has negotiated (but not necessarily executed) a term sheet, letter of intent or other similar written mutual understanding,
- does not require SCE's consent, and *provided further* that, in each case such potential Lender has a need to know this information and has agreed to keep such terms confidential;
- (iii) By SCE, to SCE's Procurement Review Group, as defined in CPUC Decision 02-08-071, subject to any confidentiality agreements or laws, regulations or regulatory decisions concerning confidentiality which are applicable to SCE's Procurement Review Group;
- (iv) By SCE, to the CPUC under seal for purposes of review subject to SCE making reasonable efforts to obtain confidentiality protection from the CPUC under Section 583 of the California Public Utilities Code or other statute, order or rule offering comparable confidentiality protection;
- (v) To the CAISO or as otherwise may reasonably be required in order to participate in any auction, market or other process pertaining to the allocation of priorities or rights related to the transmission of electric energy sold or to be sold to SCE hereunder;
- (vi) In order to comply with any Applicable Law or any exchange, control area or CAISO rule, or order issued by a court or entity with competent jurisdiction over the Party making a disclosure of Confidential Information (the "Disclosing Party"), other than to those entities set forth in Section 10.10(a)(vii);
- (vii) In order to comply with any applicable regulation, rule, or order of the CPUC, CEC, FERC, any court, administrative agency, legislative body or other tribunal, or any mandatory discovery or data request of a party to any proceeding pending before any of the foregoing;
- (viii) To any governmental body, the CPUC, the CAISO or any local control area or regional authority having jurisdiction in order to support SCE's resource adequacy requirement showings, if applicable; *provided*, SCE shall, to the extent reasonable, use reasonable efforts to limit the ability of any such applicable governmental body, CAISO, local control area or regional authority to further disclose such information;
- (ix) As may reasonably be required to participate in the WREGIS or other process recognized under Applicable Laws for the registration, transfer or ownership of Green Attributes associated with the Generating Facility;
- (x) To representatives of a Party's credit ratings agencies:

*The contents of this document are subject to restrictions on disclosure as set forth herein.*

- (1) Who have a need to review the terms and conditions of this Agreement for the purpose of assisting the Party in evaluating this Agreement for credit rating purposes and have agreed to keep this information confidential; or
- (2) With respect to the potential impact of this Agreement on the Party's financial reporting obligations;
- (xi) Disclosure of terms specified in and pursuant to Section 10.10(c);
- (xii) In connection with discovery requests or orders pertaining to the non-public terms of this Agreement as referenced in Sections 10.10(a)(vi) and 10.10(a)(vii) ("Disclosure Order") each Party shall, to the extent practicable, use reasonable efforts to:
  - (1) Notify the other Party before disclosing the Confidential Information; and
  - (2) Prevent or limit such disclosure.

After using such reasonable efforts, the Disclosing Party will not be:

- (3) Prohibited from complying with a Disclosure Order; or
- (4) Liable to the other Party for monetary or other damages incurred in connection with the disclosure of the Confidential Information.

Except as provided in the preceding sentence, the Parties are entitled to all remedies available at law or in equity to enforce, or seek relief in connection with this confidentiality obligation.

- (xiii) To the applicable Governmental Authority in connection with an application for Federal Investment Tax Credits or other government financial incentives, but in each case, (i) only such information as may be reasonably required for evaluating the project in order to grant the financial incentive and (ii) only to those individuals who have a need to know such information to evaluate the Project in order to grant such financial incentive, *provided*, in the event of any request for disclosure pursuant to the Freedom of Information Act (5 U.S.C. § 552) as amended from time to time, or similar applicable laws, Seller shall, in a timely manner, take all reasonable actions to protect the confidentiality of the Confidential Information, including demonstrating to the requesting party or applicable Governmental Authority why the Confidential Information should remain confidential.



(b) Non-Disclosure Agreement.

(i) The Non-Disclosure Agreement between the Parties attached hereto as Exhibit J is incorporated herein (the “Non-Disclosure Agreement”), and the termination date of that agreement is modified such that it will terminate on the later of:

- (1) The termination of the Non-Disclosure Agreement; or
- (2) One year after the date of termination of this Agreement.

Information provided by the Parties pursuant to this Agreement will be subject to the Non-Disclosure Agreement, or to any other agreement that the Parties negotiate to provide reasonable protection for their confidential business information or trade secrets.

(ii) Notwithstanding Section 6 of the Non-Disclosure Agreement, the term “Confidential Information” as used in the Non-Disclosure Agreement (and incorporated herein) shall be deemed to include (in addition to the information described in the Non-Disclosure Agreement) this Agreement and all oral or written communications exchanged between the Parties pursuant to this Agreement, except for communications and information described in Section 4 of the Non-Disclosure Agreement.

(iii) Confidential Information may only be used for the purposes set forth under the Non-Disclosure Agreement and for the purpose of implementing and enforcing this Agreement.

(c) RPS Confidentiality.

Notwithstanding Section 10.10(a), at any time on or after the Effective Date, either Party shall be permitted to disclose the following terms with respect to this Agreement:

- (i) Party names;
- (ii) ERR type;
- (iii) Term;
- (iv) Generating Facility location;
- (v) Contract Capacity;
- (vi) Forecasted Commercial Operation Date;
- (vii) Delivery Point; and
- (viii) Generating Facility’s expected energy deliveries.

## 10.11 Insurance.

(a) Starting on the Effective Date until the end of the Term and for such additional periods as may be specified below, Seller shall, at its own expense, provide and maintain in effect the insurance policies and minimum limits of coverage specified below, and such additional coverage as may be required by applicable law, with insurance companies which are authorized to do business in the state in which the services are to be performed and which have an A.M. Best's Insurance Rating of not less than A-:VII. The minimum insurance requirements specified herein do not in any way limit or relieve Seller of any obligation assumed elsewhere in this Agreement, including, but not limited to, Seller's defense and indemnity obligations.

(i) Workers' Compensation Insurance with the statutory limits required by the state having jurisdiction over Seller's employees;

(ii) Employer's Liability Insurance with limits of not less than:

(1) Bodily injury by accident – One Million dollars (\$1,000,000) each accident

(2) Bodily injury by disease – One Million dollars (\$1,000,000) policy limit

(3) Bodily injury by disease – One Million dollars (\$1,000,000) each employee

(iii) Commercial General Liability Insurance, (which, except with the prior written consent of SCE and subject to subsections (1) and (2) below, shall be written on an "occurrence," not a "claims-made" basis), covering all operations by or on behalf of Seller arising out of or connected with this Agreement, including coverage for bodily injury, broad form property damage, personal and advertising injury, products/completed operations, and contractual liability. Such insurance shall bear a combined single limit per occurrence and annual aggregate of not less than one million dollars (\$1,000,000), exclusive of defense costs, for all coverages. Such insurance shall contain standard cross-liability and severability of interest provisions.

If Seller elects, with SCE's written concurrence, to use a "claims made" form of Commercial General Liability Insurance, then the following additional requirements apply:

(1) The retroactive date of the policy must be prior to the Effective Date; and

(2) Either the coverage must be maintained for a period of not less than four (4) years after the Agreement terminates, or the policy must provide for a supplemental extended reporting

period of not less than four (4) years after the Agreement terminates.

- (iv) Commercial Automobile Liability Insurance covering bodily injury and property damage with a combined single limit of not less than One Million dollars (\$1,000,000) per occurrence. Such insurance shall cover liability arising out of Seller's use of all owned (if any), non-owned and hired automobiles in the performance of the Agreement.
  - (v) Umbrella/Excess Liability Insurance, written on an "occurrence," not a "claims-made" basis, providing coverage excess of the underlying Employer's Liability, Commercial General Liability, and Commercial Automobile Liability insurance, on terms at least as broad as the underlying coverage, with limits of not less than Ten Million Dollars (\$10,000,000) per occurrence and in the annual aggregate. The insurance requirements of this Section 10.11 can be provided by any combination of Seller's primary and excess liability policies.
- (b) The insurance required above shall apply as primary insurance to, without a right of contribution from, any other insurance maintained by or afforded to SCE, its subsidiaries and affiliates, and their respective officers, directors, shareholders, agents, and employees, regardless of any conflicting provision in Seller's policies to the contrary. To the extent permitted by law, Seller and its insurers shall be required to waive all rights of recovery from or subrogation against SCE, its subsidiaries and affiliates, and their respective officers, directors, shareholders, agents, employees and insurers. The Commercial General Liability and Umbrella/Excess Liability insurance required above shall name SCE, its subsidiaries and affiliates, and their respective officers, directors, shareholders, agents and employees, as additional insureds for liability arising out of Seller's construction, ownership or Operation of the Generating Facility.
- (c) At the time this Agreement is executed, or within a reasonable time thereafter, and within a reasonable time after coverage is renewed or replaced, Seller shall furnish to SCE certificates of insurance evidencing the coverage required above, written on forms and with deductibles reasonably acceptable to SCE. All deductibles, co-insurance and self-insured retentions applicable to the insurance above shall be paid by Seller. All certificates of insurance shall note that the insurers issuing coverage shall endeavor to provide SCE with at least thirty (30) days' prior written notice in the event of cancellation of coverage. SCE's receipt of certificates that do not comply with the requirements stated herein, or Seller's failure to provide certificates, shall not limit or relieve Seller of the duties and responsibility of maintaining insurance in compliance with the requirements in this Section 10.11 and shall not constitute a waiver of any of the requirements in this Section 10.11.

*The contents of this document are subject to restrictions on disclosure as set forth herein.*

- (d) If Seller fails to comply with any of the provisions of this Section 10.11, Seller, among other things and without restricting SCE's remedies under the law or otherwise, shall, at its own cost and expense, act as an insurer and provide insurance in accordance with the terms and conditions above. With respect to the required Commercial General Liability, Umbrella/Excess Liability and Commercial Automobile Liability insurance, Seller shall provide a current, full and complete defense to SCE, its subsidiaries and affiliates, and their respective officers, directors, shareholders, agents, employees, assigns, and successors in interest, in response to a third party claim in the same manner that an insurer would have, had the insurance been maintained in accordance with the terms and conditions set forth above.

10.12 Nondedication.

Notwithstanding any other provisions of this Agreement, neither Party dedicates any of the rights that are or may be derived from this Agreement or any part of its facilities involved in the performance of this Agreement to the public or to the service provided under this Agreement, and this service shall cease upon termination of this Agreement.

10.13 Mobile Sierra.

Absent the agreement of all Parties to the proposed change, the standard of review for changes to any rate, charge, classification, term or condition of this Agreement, whether proposed by a Party (to the extent that any waiver in the paragraph below is unenforceable or ineffective as to such Party), a non-party or FERC acting sua sponte, shall be the 'public interest' standard of review set forth in *United Gas Pipe Line Co. v. Mobile Gas Service Corp.*, 350 U.S. 332 (1956) and *Federal Power Commission v. Sierra Pacific Power Co.*, 350 U.S. 348 (1956) (the 'Mobile Sierra' doctrine).

Notwithstanding any provision of this Agreement, and absent the prior written agreement of the Parties, each Party, to the fullest extent permitted by Applicable Laws, for itself and its respective successors and assigns, hereby also expressly and irrevocably waives any rights it can or may have, now or in the future, whether under Sections 205, 206, or 306 of the Federal Power Act or otherwise, to seek to obtain from FERC by any means, directly or indirectly (through complaint, investigation, supporting a third party seeking to obtain or otherwise), and each hereby covenants and agrees not at any time to seek to so obtain, an order from FERC changing any Section of this Agreement specifying any rate or other material economic terms and conditions agreed to by the Parties.

10.14 Simple Interest Payments.

Except as specifically provided in this Agreement, any outstanding and past due amounts owing and unpaid by either Party under the terms of this Agreement will be eligible to receive a Simple Interest Payment calculated using the Interest Rate for the number of days between the date due and the date paid.

## 10.15 Payments.

Payments to be made under this Agreement must be made by wire transfer.

## 10.16 Seller Ownership and Control of Generating Facility.

Seller agrees, that, in accordance with FERC Order No. 697, upon request of SCE, Seller shall submit a letter of concurrence in support of any affirmative statement by SCE that the contractual arrangement set forth in this Agreement does not transfer “ownership or control of generation capacity” from Seller to SCE as the term “ownership or control of generation capacity” is used in 18 CFR Section 35.42. Seller also agrees that it will not, in filings, if any, made subject to FERC Order Nos. 652 and 697, claim that the contractual arrangement set forth in this Agreement conveys ownership or control of generation capacity from Seller to SCE.

## 10.17 Required Material.

Seller acknowledges and agrees that, notwithstanding anything to the contrary set forth herein, any review, approval, request, or requirement of any Required Material shall mean only that such Required Material is acceptable to SCE solely for SCE’s internal purposes and benefit, and will not in any way be construed to mean that such Required Material is accurate, suitable for its intended purpose, in compliance with any Applicable Law or other requirement, or endorsed for the benefit of any other party, including Seller. Further, Seller acknowledges and agrees that SCE shall have no liability to Seller or any other third party with respect to any Required Material so reviewed, approved, requested or required by SCE or on SCE’s behalf.

---

\*\*\* End of ARTICLE TEN \*\*\*

## **ARTICLE ELEVEN. CHANGE IN ELECTRIC MARKET DESIGN**

If a Change in CAISO Tariff renders this Agreement or any terms herein incapable of being performed or administered, then either Party, on Notice, may request the other Party to enter into negotiations to make the minimum changes to this Agreement necessary to make this Agreement capable of being performed and administered, while attempting to preserve to the maximum extent possible the benefits, burdens and obligations set forth in this Agreement as of the Effective Date.

Upon receipt of a Notice requesting negotiations, the Parties shall negotiate in good faith.

If the Parties are unable, within sixty (60) days after the sending of the Notice requesting negotiations, either to agree upon changes to this Agreement or to resolve issues relating to changes to this Agreement, then either Party may submit issues pertaining to changes to this Agreement to mediation and arbitration as provided in Article Twelve.

A change in cost will not in itself be deemed to render this Agreement or any terms therein incapable of being performed or administered, or constitute, or form the basis of, a Force Majeure Event.

---

\*\*\* *End of ARTICLE ELEVEN* \*\*\*

**ARTICLE TWELVE. MEDIATION AND ARBITRATION****12.01 Dispute Resolution.**

Other than requests for provisional relief under Section 12.04, any and all Disputes which the Parties have been unable to resolve by informal methods after undertaking a good faith effort to do so, must first be submitted to mediation under the procedures described in Section 12.02 below, and if the matter is not resolved through mediation, *then* for final and binding arbitration under the procedures described in Section 12.03 below; *provided*, if a Party receiving Notice of mediation in accordance with Section 12.02 does not respond to the Notice within forty-five (45) days of its receipt, the other Party may immediately pursue arbitration in accordance with Section 12.03.

The Parties waive any right to a jury and agree that there will be no interlocutory appellate relief (such as writs) available.

**12.02 Mediation.**

Either Party may initiate mediation by providing Notice to the other Party in accordance with Section 10.08 of a written request for mediation, setting forth a description of the Dispute and the relief requested.

The Parties will cooperate with one another in selecting the mediator (“Mediator”) from the panel of neutrals from Judicial Arbitration and Mediation Services, Inc. (“JAMS”), its successor, or any other mutually acceptable non-JAMS Mediator, and in scheduling the time and place of the mediation.

Such selection and scheduling will be completed within forty-five (45) days after Notice of the request for mediation.

Unless otherwise agreed to by the Parties, the mediation will not be scheduled for a date that is greater than one hundred twenty (120) days from the date of Notice of the request for mediation.

The Parties covenant that they will participate in the mediation in good faith, and that they will share equally in its costs (other than each Party’s individual attorneys’ fees and costs related to the Party’s participation in the mediation, which fees and costs will be borne by such Party).

All offers, promises, conduct and statements, whether oral or written, made in connection with or during the mediation by either of the Parties, their agents, representatives, employees, experts and attorneys, and by the Mediator or any of the Mediator’s agents, representatives and employees, will not be subject to discovery and will be confidential, privileged and inadmissible for any purpose, including impeachment, in any arbitration or other proceeding between or involving the Parties, or either of them, *provided*, evidence that is otherwise admissible or discoverable will not be rendered inadmissible or non-discoverable as a result of its use in the mediation.

**12.03 Arbitration.**

Either Party may initiate binding arbitration with respect to the matters first submitted to mediation by providing Notice in accordance with Section 10.08 of a demand for binding arbitration before a single, neutral arbitrator (the "Arbitrator") at any time following the unsuccessful conclusion of the mediation provided for in Section 12.02, above.

The Parties will cooperate with one another in selecting the Arbitrator within sixty (60) days after Notice of the demand for arbitration and will further cooperate in scheduling the arbitration to commence no later than one hundred eighty (180) days from the date of Notice of the demand.

If, notwithstanding their good faith efforts, the Parties are unable to agree upon a mutually-acceptable Arbitrator, the Arbitrator will be appointed as provided for in California Code of Civil Procedure Section 1281.6.

To be qualified as an Arbitrator, each candidate must be a retired judge of a trial court of any state or federal court, or retired justice of any appellate or supreme court.

Unless otherwise agreed to by the Parties, the individual acting as the Mediator will be disqualified from serving as the Arbitrator in the dispute, although the Arbitrator may be another member of the JAMS panel of neutrals or such other panel of neutrals from which the Parties have agreed to select the Mediator.

Upon Notice of a Party's demand for binding arbitration, such Dispute submitted to arbitration, including the determination of the scope or applicability of this agreement to arbitrate, will be determined by binding arbitration before the Arbitrator, in accordance with the laws of the State of California, without regard to principles of conflicts of laws.

Except as provided for herein, the arbitration will be conducted by the Arbitrator in accordance with the rules and procedures for arbitration of complex business disputes for the organization with which the Arbitrator is associated.

Absent the existence of such rules and procedures, the arbitration will be conducted in accordance with the California Arbitration Act, California Code of Civil Procedure Section 1280 *et seq.* and California procedural law (including the Code of Civil Procedure, Civil Code, Evidence Code and Rules of Court, but excluding local rules).

Notwithstanding the rules and procedures that would otherwise apply to the arbitration, and unless the Parties agree to a different arrangement, the place of the arbitration will be in Los Angeles County, California.

Also notwithstanding the rules and procedures that would otherwise apply to the arbitration, and unless the Parties agree to a different arrangement, discovery will be limited as follows:

- (a) Before discovery commences, the Parties shall exchange an initial disclosure of all documents and percipient witnesses which they intend to rely upon or



- use at any arbitration proceeding (except for documents and witnesses to be used solely for impeachment);
- (b) The initial disclosure will occur within thirty (30) days after the initial conference with the Arbitrator or at such time as the Arbitrator may order;
  - (c) Discovery may commence at any time after the Parties' initial disclosure;
  - (d) The Parties will not be permitted to propound any interrogatories or requests for admissions;
  - (e) Discovery will be limited to twenty-five (25) document requests (with no subparts), three (3) lay witness depositions, and three (3) expert witness depositions (unless the Arbitrator holds otherwise following a showing by the Party seeking the additional documents or depositions that the documents or depositions are critical for a fair resolution of the Dispute or that a Party has improperly withheld documents);
  - (f) Each Party is allowed a maximum of three (3) expert witnesses, excluding rebuttal experts;
  - (g) Within sixty (60) days after the initial disclosure, or at such other time as the Arbitrator may order, the Parties shall exchange a list of all experts upon which they intend to rely at the arbitration proceeding;
  - (h) Within thirty (30) days after the initial expert disclosure, the Parties may designate a maximum of two (2) rebuttal experts;
  - (i) Unless the Parties agree otherwise, all direct testimony will be in form of affidavits or declarations under penalty of perjury; and
  - (j) Each Party shall make available for cross examination at the arbitration hearing its witnesses whose direct testimony has been so submitted.

Subject to Article Seven, the Arbitrator will have the authority to grant any form of equitable or legal relief a Party might recover in a court action. The Parties acknowledge and agree that irreparable damage would occur if certain provisions of this Agreement are not performed in accordance with the terms of the Agreement, that money damages would not be a sufficient remedy for any breach of these provisions of this Agreement, and that the Parties shall be entitled, without the requirement of posting a bond or other security, to specific performance and injunctive or other equitable relief as a remedy for a breach of Section 2.06(b), 3.01, 3.02, 3.06(i), 3.09 or 10.10 of this Agreement.

Judgment on the award may be entered in any court having jurisdiction.

The Arbitrator must, in any award, allocate all of the costs of the binding arbitration (other than each Party's individual attorneys' fees and costs related to the Party's participation in the arbitration, which fees and costs will be borne by such Party),

including the fees of the Arbitrator and any expert witnesses, against the Party who did not prevail.

Until such award is made, however, the Parties will share equally in paying the costs of the arbitration.

#### 12.04 Provisional Relief.

The Parties acknowledge and agree that irreparable damage would occur if certain provisions of this Agreement are not performed in accordance with the terms of this Agreement, that money damages would not be a sufficient remedy for any breach of these provisions of this Agreement, and that the Parties shall be entitled, without the requirement of posting a bond or other security, to seek a preliminary injunction, temporary restraining order, or other provisional relief as a remedy for a breach of Section 2.06(b), 3.01, 3.02, 3.06(i), 3.09 or 10.10 of this Agreement in any court of competent jurisdiction, notwithstanding the obligation to submit all other disputes (including all claims for monetary damages under this Agreement) to arbitration pursuant to Section 12.01. The Parties further acknowledge and agree that the results of the arbitration may be rendered ineffectual without the provisional relief.

Such a request for provisional relief does not waive a Party's right to seek other remedies for the breach of the provisions specified above in accordance with Section 12.01, notwithstanding any prohibition against claim-splitting or other similar doctrine. The other remedies that may be sought include specific performance and injunctive or other equitable relief, plus any other remedy specified in this Agreement for the breach of the provision, or if the Agreement does not specify a remedy for the breach, all other remedies available at law or equity to the Parties for the breach.

---

\*\*\* *End of ARTICLE TWELVE* \*\*\*

In WITNESS WHEREOF, the Parties have caused this Agreement to be duly executed as of the Effective Date first written:

**SOLAR STAR CALIFORNIA XX,  
LLC,**

**SOUTHERN CALIFORNIA EDISON  
COMPANY,**

a Delaware limited liability company.

a California corporation.

By: SunPower Corporation, Systems

By:

its sole member



Jean Wilson

Marc L. Ulrich

*Senior Vice President and General  
Manager*

*Vice President of  
Renewable and Alternative Power*

Date: Jan. 3, 2011

Date: Jan. 5, 2011

## EXHIBITS

**EXHIBIT A***Definitions*

The following terms shall have the following meaning for purposes of this Agreement.

1. “AC” means alternating current.
2. “Accepted Compliance Costs” has the meaning set forth in Section 1.10(a).
3. “Actual Authorized Capacity” means the quantity of capacity that Seller has authority to develop and construct under the Construction Permits pursuant to the Reduced Capacity Authority to Construct.
4. “Actual Availability” means the available capacity for each hour of the applicable month as set forth in Exhibit S in the Actual Availability Report.
5. “Actual Availability Report” means a report to be prepared by Seller in the form of Exhibit S containing the information described in Section 3.24.
6. “Additional Capacity” means any capacity in excess of the quantity of Contract Capacity specified in Section 1.01(h) and Unincluded Capacity.
7. “Affiliate” means, with respect to a Party, any entity that, directly or indirectly, through one or more intermediaries, controls, or is controlled by, or is under common control with that Party.
8. “Agreement” has the meaning set forth in the Preamble.
9. “Annual Energy Yield Factor” means the annual AC energy in kWh that is expected to be delivered to SCE per installed peak DC power in kW<sub>PDC</sub> of Photovoltaic Modules.
10. “Applicable Laws” means all constitutions, treaties, laws, ordinances, rules, regulations, interpretations, permits, judgments, decrees, injunctions, writs and orders of any Governmental Authority that apply to either or both of the Parties, the Generating Facility or the terms of this Agreement.
11. “Arbitrator” has the meaning set forth in Article Twelve.
12. “Availability Incentive Payments” has the meaning set forth in the CAISO Tariff.
13. “Availability Standards” has the meaning set forth in the CAISO Tariff.
14. “Availability Workbook” has the meaning set forth in Exhibit S.
15. “Banked Curtailed Energy” means the sum of the cumulative quantity in any Term Year of Curtailed Product (i) that exceeds the Curtailment Cap for any Term Year and (ii) for which SCE paid the Product Price.
16. “Bankrupt” means with respect to any entity, such entity:

*The contents of this document are subject to restrictions on disclosure as set forth herein.*

- (a) Files a petition or otherwise commences, authorizes or acquiesces in the commencement of a proceeding or cause of action under any bankruptcy, insolvency, reorganization or similar law, or has any such petition filed or commenced against it and the petition commenced against it is not dismissed within thirty (30) days of filing;
  - (b) Makes an assignment or any general arrangement for the benefit of creditors;
  - (c) Otherwise becomes bankrupt or insolvent (however evidenced);
  - (d) Has a liquidator, administrator, receiver, trustee, conservator or similar official appointed with respect to such entity or any substantial portion of its property or assets; or
  - (e) Is generally unable to pay its debts as they fall due.
17. “Bankruptcy Code” means the United States Bankruptcy Code (11 U.S.C. §101 *et seq.*), as amended, and any successor statute.
18. “Bid” has the meaning as set forth in the CAISO Tariff.
19. “Business Day” means any day except a Saturday, Sunday, a Federal Reserve Bank holiday, or the Friday following Thanksgiving. A Business Day begins at 8:00 a.m. and end at 5:00 p.m. local time for the Party sending the Notice or payment or performing a specified action.
20. “Buyer” means Southern California Edison Company.
21. “CAISO” means the California Independent System Operator Corporation or successor entity.
22. “CAISO Approved Meter” means a CAISO approved revenue quality meter or meters, CAISO approved data processing gateway or remote intelligence gateway, telemetering equipment and data acquisition services sufficient for monitoring, recording and reporting, in real time, all electric energy produced by the Generating Facility less Station Use.
23. “CAISO Controlled Grid” has the meaning as set forth in the CAISO Tariff.
24. “CAISO Costs” means the debits, costs, penalties and interest that are directly assigned by the CAISO to the CAISO Resource ID for the Generating Facility for, or attributable to, Scheduling or deliveries from the Generating Facility under this Agreement in each applicable Settlement Interval.
25. “CAISO Declared Over-Generation Condition” means a CAISO declared condition on the CAISO Controlled Grid where the sum of the desired generation output of all of the Scheduling Coordinators in the Control Area, absent mitigation, would be greater than the system load.
26. “CAISO Forecasted Over-Generation Condition” means a CAISO forecasted condition on the CAISO Controlled Grid where the sum of the desired generation

- output of all of the Scheduling Coordinators in the Control Area, absent mitigation, would be greater than the system load.
27. “CAISO Markets” has the meaning as set forth in the CAISO Tariff.
  28. “CAISO Resource ID” means the number or name assigned by the CAISO to the CAISO Approved Meter.
  29. “CAISO Revenues” means the credits and other payments incurred or received by SCE as a result of energy from the Generating Facility delivered to any CAISO administered market by Seller, including costs and revenues associated with CAISO dispatches, for each applicable Settlement Interval.
  30. “CAISO Sanctions” means any sanctions directly assigned by the CAISO to the CAISO Resource ID for the Generating Facility or attributable to, Scheduling or deliveries from the Generating Facility under this Agreement for each applicable Settlement Interval.
  31. “CAISO Tariff” means the California Independent System Operator Corporation Operating Agreement and Tariff, including the rules, protocols, procedures and standards attached thereto, as the same may be amended or modified from time-to-time and approved by FERC.
  32. “Calculation Period” means the twenty-four (24) month period immediately preceding the end of a Term Year.
  33. “California Renewables Portfolio Standard” means the California Public Utilities Code Section 399.11, *et seq.*
  34. “Capacity Attributes” means any and all current or future defined characteristics, certificates, tags, credits, ancillary service attributes, or accounting constructs, howsoever entitled, including any accounting construct counted toward any resource adequacy requirements, attributed to or associated with the Generating Facility or any unit of generating capacity of the Generating Facility throughout the Delivery Term.
  35. “Capacity Permit Reduction Notice” has the meaning set forth in Section 1.01(h)(i).
  36. “Capacity Permit Reduction Quantity” means the difference between the Contract Capacity of 276 MW and the Permit Adjusted Contract Capacity specified in the Capacity Permit Reduction Notice.
  37. “CEC” means the California Energy Commission.
  38. “CEC Certification” means certification by the CEC that the Generating Facility is an ERR for purposes of the RPS Legislation and that all electric energy produced by the Generating Facility qualifies as generation from an ERR for purposes of the RPS Legislation.
  39. “CEC Pre-Certification” means provisional certification of the proposed Generating Facility as an ERR by the CEC upon submission by a facility of a complete CEC-RPS-1B application and required supplemental information.

*The contents of this document are subject to restrictions on disclosure as set forth herein.*

40. “CEC Verification” means verification by the CEC based on ongoing reporting by Seller that the Generating Facility is an ERR for purposes of the RPS Legislation and that all electric energy produced by the Generating Facility qualifies as generation from an ERR for purposes of the RPS Legislation.
41. “CFR” means the Code of Federal Regulations, as may be amended from time to time.
42. “Change in CAISO Tariff” means that, other than (i) the Availability Standards program of Section 40.9 of the CAISO Tariff or (ii) changes related to the Market Redesign and Technology Update that became effective on or before the Effective Date, the CAISO Tariff has been changed and such change has a material adverse impact on either Party, or the CAISO has been dissolved or replaced and any successor to the CAISO operates under rules, protocols, procedures or standards that differ in a material respect from the CAISO Tariff, after the Effective Date.
43. “Change of Control” with respect to Seller, means any direct or indirect change of control of Seller (whether voluntary or by operation of law) or the Parent Company of Seller holding a direct or indirect equity, partnership, membership or ownership interest in Seller or Parent Company of Seller if such interest constitutes more than twenty percent (20%) of the ownership interests of Seller or Parent Company of Seller, or a merger, consolidation or reorganization of Seller or Parent Company of Seller.

For purposes of this definition of Change of Control, “Parent Company” means the entity that is in the same position or closest to the position of SunPower Corporation Systems as of the Effective Date of this Agreement, in terms of decision making control, financial structure and financial strength. Accordingly, as of the Effective Date, SunPower Corporation Systems, a wholly owned subsidiary of SunPower Corporation, is Seller’s Parent Company.

44. “Check Meter” means the SCE revenue-quality meter section(s) or meter(s), which SCE may require at its discretion, as set forth in Section 3.08(b), and which will include those devices normally supplied by SCE or Seller under the applicable utility electric service requirements.
45. “Claiming Party” has the meaning set forth in Section 5.02.
46. “Collateral Assignment Agreement” has the meaning set forth in Section 10.05.
47. “Commercial Operation” is the status of the Generating Facility upon Seller’s satisfaction of all of the conditions set forth in Section 2.03(b) and as of the Commercial Operation Date.
48. “Commercial Operation Date” has the meaning set forth in Section 2.03(b).
49. “Commercial Operation Deadline” has the meaning set forth in Section 1.04.
50. “Compliance Actions” has the meaning set forth in Section 1.10(a).

*The contents of this document are subject to restrictions on disclosure as set forth herein.*



51. “Compliance Expenditure Cap” means the dollar amount set forth in Section 1.10(a).
52. “Confidential Information” has the meaning set forth in Section 10.10(b)(ii).
53. “Construction Permits” means the conditional use permit and authority to construct or any other permit required to grant Seller the authority to develop and construct the Generating Facility consistent with applicable environmental rules and regulations. Construction Permits do not include permits for work that cannot be or typically is not commenced until construction of the Generating Facility is complete or nearly complete, such as permits for grading or paving roads or to address water run-off at the Site.
54. “Contract Capacity” means the electric energy generating capacity, set forth in Section 1.01(h), that Seller commits to install at the Site.
55. “Control Area” means the electric power system (or combination of electric power systems) under the operational control of the CAISO or any other electric power system under the operational control of another organization vested with authority comparable to that of the CAISO.
56. “Costs” means, with respect to the Non-Defaulting Party, brokerage fees, commissions, legal expenses and other similar third party transaction costs and expenses reasonably incurred by that Party in entering into any new arrangement which replaces this Agreement.
57. “CPUC” means the California Public Utilities Commission.
58. “CPUC Approval” means a final and non-appealable order of the CPUC, without conditions or modifications unacceptable to the Parties, or either of them, which contains the following terms:
- (a) Approves this Agreement in its entirety, including payments to be made by the Buyer, subject to CPUC review of the Buyer’s administration of the Agreement; and
  - (b) Finds that any procurement pursuant to this Agreement is procurement from an eligible renewable energy resource for purposes of determining Buyer’s compliance with any obligation that it may have to procure eligible renewable energy resources pursuant to the California Renewables Portfolio Standard (Public Utilities Code Section 399.11 *et seq.*), Decision 03-06-071, or other applicable law.
- CPUC Approval will be deemed to have occurred on the date that a CPUC decision containing such findings becomes final and non-appealable.
59. “Credit Rating” means with respect to any entity, on the relevant date of determination, the respective ratings then assigned to such entity’s unsecured, senior long-term debt or deposit obligations (not supported by third party credit enhancement) by S&P, Fitch or Moody’s. If no rating is assigned to such entity’s unsecured, senior long-term debt or deposit obligation by S&P, Fitch or Moody’s,

- then “Credit Rating” means the general corporate credit rating or long-term issuer rating assigned by the other two ratings agencies.
60. “Cross Default Amount” means the dollar amount set forth in Section 1.09(c).
61. “Current Inverters” means devices used to convert DC electric energy to AC electric energy.
62. “Curtailed Product” means energy that could have been delivered to the Delivery Point by Seller during the Delivery Term but which did not receive a Schedule in the CAISO Day-Ahead Market plus Real-Time Over-Schedule Generation Curtailment Quantity, and which Seller did not deliver to SCE. The amount of energy that could have been delivered will be determined in accordance with Section 3.23 and Exhibit M, “Sellers Estimate of Lost Output”.
63. “Curtailed Product Payment” means the sum of all payments for Curtailed Product plus payments for OSGC Quantity, as set forth in Section 4.02.
64. “Curtailed Return Term” has the meaning set forth in Section 1.06(b)(ii).
65. “Curtailed Return Term Notice” has the meaning set forth in Section 1.06(b).
66. “Curtailment Cap” is the yearly quantity (Term Year), in MWh, set forth in Section 1.10(b).
67. “Daily Delay Liquidated Damages” has the meaning set forth in Section 3.06(c).
68. “Day-Ahead” has the meaning set forth in the CAISO Tariff.
69. “Day-Ahead Market” has the meaning set forth in the CAISO Tariff.
70. “Day-Ahead Price” means the CAISO Day-Ahead Market Locational Marginal Price in each applicable Settlement Interval for electric energy (including the energy, congestion and losses components) at the Generating Facility’s PNode (as published by the CAISO) which is the pricing point used by the CAISO for settlements of this Generating Facility.
71. “DC” means direct current.
72. “DC Collection System” means the DC equipment, cables, components, devices and materials that interconnect the Photovoltaic Modules with the Current Inverters.
73. “Defaulting Party” has the meaning set forth in Section 6.01.
74. “Delivery Point” means the point of delivery of Product to the CAISO-Controlled Grid, as specified in Section 1.01(f) and set forth in the single-line diagram of the CAISO-Controlled Grid interconnection attached hereto as Exhibit B-2.
75. “Delivery Term” means the period beginning with Initial Synchronization and continuing throughout the end of the Term.
76. “Demonstrated Contract Capacity” has the meaning set forth in Exhibit L.
77. “Development Security” has the meaning set forth in Section 3.06(a).

*The contents of this document are subject to restrictions on disclosure as set forth herein.*

78. “Disclosing Party” has the meaning set forth in Section 10.10(a)(vi).
79. “Disclosure Order” has the meaning set forth in Section 10.10(a)(xii).
80. “Dispatch Instruction” has the meaning set forth in the CAISO Tariff.
81. “Dispute” means any and all disputes, claims or controversies arising out of, relating to, concerning or pertaining to the terms of this Agreement, or to either Party’s performance or failure of performance under this Agreement.
82. “Disqualified Stock” means any capital stock that, by its terms (or by the terms of any security into which such stock is convertible, or for which such stock is exchangeable, in each case at the option of the holder of the capital stock), or upon the happening of any event, matures or is mandatorily redeemable, pursuant to a sinking fund obligation or otherwise, or is redeemable at the option of the holder of the capital stock, in whole or in part, on or before the date that is ninety-one (91) days after the expiration of the Term of this Agreement.
83. “Early Termination Date” has the meaning set forth in Section 6.02(a).
84. “Effective Date” has the meaning set forth in the Preamble.
85. “Emergency” means:
- (a) An actual or imminent condition or situation which jeopardizes the integrity of Transmission Provider’s electric system or the integrity of any other systems to which the Transmission Provider’s electric system is connected, as determined by the Transmission Provider in its reasonable discretion, or any condition so defined and declared by the CAISO; or
  - (b) An emergency condition as defined under an interconnection agreement and any abnormal interconnection or system condition that requires automatic or immediate manual action to prevent or limit loss of load or generation supply, that could adversely affect the reliability of the Transmission Provider’s electric system or generation supply, that could adversely affect the reliability of any interconnected system, or that could otherwise pose a threat to public safety.
86. “Energy Communication Network” means the CAISO infrastructure network (data highway) used by all CAISO participants to exchange data to and from resources and CAISO.
87. “Energy Deviations” means the absolute value of the difference, in kWh, in any Settlement Interval between:
- (a) Forecast-Derived Energy; and
  - (b) Metered Amounts plus Curtailed Product plus OSGC Quantity.
88. “Equitable Defense” means any bankruptcy, insolvency, reorganization or other laws affecting creditors’ rights generally, and with regard to equitable remedies, the

- discretion of the court before which proceedings to obtain equitable remedies may be pending.
89. “ERR” has the meaning set forth in Section 10.02(b)(i).
90. “Event of Default” has the meaning set forth in Section 6.01.
91. “Event of Deficient Energy Deliveries” means any instance in which Seller fails to meet Seller’s Energy Delivery Obligation as determined in accordance with Section 3.07(a)(ii), which failure results in Seller’s obligation to pay the applicable Product Replacement Damage Amount.
92. “Expected Annual Net Energy Production” means the Generating Facility’s expected annual Qualified Amounts, as calculated in accordance with Section 1.01(i).
93. “Federal Funds Effective Rate” means the annual interest rate posted opposite the caption “Federal Funds (effective)” as set forth in the weekly statistical release as H.15(519), or any successor publication, published by the Board of Governors of the Federal Reserve System.
94. “Federal Investment Tax Credit” means investment tax credit under Section 48 of the Internal Revenue Code as in effect from time-to-time throughout the Delivery Term or any successor or other provision providing for a federal tax credit determined by reference to capital investment in equipment used to produce renewable electric energy from solar energy resources for which Seller, as the owner of the Generating Facility, is eligible.
95. “Federal Cash Grant” means a cash grant in *lieu* of investment tax credit under Section 48 of the Internal Revenue Code as in effect from time-to-time throughout the Delivery Term or any successor provision providing for a cash grant in *lieu* of a federal investment tax credit determined by reference to capital investment in equipment used to produce renewable electric energy from solar energy resources for which Seller, as the owner of the Generating Facility, is eligible.
96. “Federal Tax Credit Legislation” means validly enacted federal legislation extending the applicability and rate of the investment tax credit (26 U.S.C. § 48) to owners of generating facilities that use solar energy to produce electric energy that are placed in service on or before the Commercial Operation Deadline, on terms no less favorable to owners of solar energy generating facilities than those available with respect to such facilities placed in service on or before January 1, 2017 pursuant to the law governing Investment Tax Credits as in effect on the Effective Date.
97. “FERC” means the Federal Energy Regulatory Commission.
98. “Firm Operation Date” has the meaning set forth in Section 1.05.
99. “Fitch” means Fitch Ratings Ltd. or its successor.
100. “Force Majeure” means any occurrence that was not anticipated as of the Effective Date that:

- (a) In whole or in part:
  - i) Delays a Party's performance under this Agreement;
  - ii) Causes a Party to be unable to perform its obligations; or
  - iii) Prevents a Party from complying with or satisfying the conditions of this Agreement;
- (b) Is not within the control of that Party; and
- (c) The Party has been unable to overcome by the exercise of due diligence, including an act of God, flood, drought, earthquake, storm, fire, pestilence, lightning, volcanic eruption and other natural catastrophes, epidemic, war, riot, civil disturbance or disobedience, terrorism, sabotage, strike or labor dispute, or actions or inactions of any Governmental Authority (including a change in Applicable Laws but excluding Seller's compliance obligations as set forth in Section 3.20), or curtailment or reduction in deliveries at the direction of a Transmission Provider or the CAISO (except as set forth below).

Force Majeure does not include:

- (d) The lack of wind, sun or other fuel source of an inherently intermittent nature, except to the extent caused by an event that otherwise qualifies as a Force Majeure under (a), (b) and (c) of this definition;
  - (e) Reductions in generation from the Generating Facility resulting from ordinary wear and tear, deferred maintenance or Operator error; or
  - (f) Curtailment or reduction in deliveries at the direction of a Transmission Provider or the CAISO when the basis of the curtailment or reduction in deliveries ordered by a Transmission Provider or the CAISO is congestion arising in the ordinary course of operations of the Transmission Provider's system or the CAISO Controlled Grid, including congestion caused by outages or capacity reductions for maintenance, construction or repair.
101. "Forecast" means an hourly available capacity forecast which will be the sum of the continuous electrical output ratings for Current Inverters (in MWs) in the Generating Facility that are operational, submitted in accordance with Exhibit D.
102. "Forecast-Derived Energy" means the amount of energy in MWh expected to be generated by the Generating Facility, as determined by SCE based upon the Forecast provided by Seller in accordance with this Agreement, and as may be adjusted for any additional energy that is available pursuant to an updated Forecast submitted in accordance with Exhibit D.
103. "Forecasted Commercial Operation Date" means the date Seller anticipates, as of the Effective Date, will be the Commercial Operation Date, as set forth in Section 1.03.

104. “Forecasted Initial Synchronization Date” means the date Seller anticipates, as of the Effective Date, will be the date for Initial Synchronization, as set forth in Section 1.02.

105. “Forecasting” means the action of Seller in preparing and submitting the Forecasts to SCE.

106. “Forward Settlement Amount” means the Non-Defaulting Party’s Costs and Losses, on the one hand, netted against its Gains, on the other.

If the Non-Defaulting Party’s Costs and Losses exceed its Gains, then the Forward Settlement Amount shall be an amount owing to the Non-Defaulting Party.

If the Non-Defaulting Party’s Gains exceed its Costs and Losses, then the Forward Settlement Amount shall be zero dollars (\$0).

The Forward Settlement Amount does not include consequential, incidental, punitive, exemplary or indirect or business interruption damages.

107. “Full Capacity Deliverability Status” has the meaning set forth in the CAISO Tariff.

108. “GAAP” means accounting principles generally accepted in the United States of America.

109. “Gains” means, with respect to any Party, an amount equal to the present value of the economic benefit to it, if any (exclusive of Costs), resulting from the termination of this Agreement for the remaining Term of this Agreement, determined in a commercially reasonable manner.

Factors used in determining the economic benefit to a Party may include, without limitation, reference to information supplied by one or more third parties, which shall exclude Affiliates of the Non-Defaulting Party, including without limitation, quotations (either firm or indicative) of relevant rates, prices, yields, yield curves, volatilities, spreads or other relevant market data in the relevant markets, comparable transactions, forward price curves based on economic analysis of the relevant markets, settlement prices for comparable transactions at liquid trading hubs (e.g., NYMEX), all of which should be calculated for the remaining Term of this Agreement, and includes the value of Green Attributes, Capacity Attributes and Resource Adequacy Benefits.

Only if the Non-Defaulting Party is unable, after using commercially reasonable efforts, to obtain third party information to determine the gain of economic benefits, *then* the Non-Defaulting Party may use information available to it internally suitable for this purpose in accordance with prudent industry practices.

110. “Generating Facility” means Seller’s electric generating facility as more particularly described in Exhibit B-1 together with all materials, equipment systems, structures, features and improvements necessary to produce electric energy at the facility, excluding the Site, land rights and interests in land.

111. “Generating Facility Capacity” means the Generating Facility’s total rated electric alternating current energy generating capacity determined as the lesser of:
- (a) The sum of the Inverter Block Unit Capacities of all Inverter Blocks Units in the Generating Facility; or
  - (b) The continuous output power rating at the expected operating power factor of the step-up transformer that connects the Generating Facility to the Transmission Provider’s system.
112. “Generating Facility Energy Yield Curve” means a table used to estimate the Generating Facility’s Metered Amounts, in kWh, as a function of the recorded plane of array insolation, in kWh per square meter, at the Site as described in Exhibit M.
113. “Generation Management System” or “GMS” means the automated system or its successor employed by SCE real time operations to remotely monitor the Generating Facility.
114. “Generation Operations Center” or “GOC” means the location of SCE’s real time operations personnel.
115. “Generator Operator” means the entity that Operates the Generating Facility and performs the functions of supplying energy and interconnected operations services as described in the NERC Reliability Standards.
116. “Generator Operator Obligations” means the obligations of a Generator Operator as set forth in all applicable NERC Reliability Standards.
117. “Generator Owner” means an entity that owns the Generating Facility and has registered with NERC as the entity responsible for complying with those NERC Reliability Standards applicable to owners of generating units as set forth in the NERC Reliability Standards.
118. “Generator Owner Obligations” means the obligations of a Generator Owner as set forth in all applicable NERC Reliability Standards.
119. “Governmental Authority” means:
- (a) Any federal, state, local, municipal or other government;
  - (b) Any governmental, regulatory or administrative agency, commission, or other authority lawfully exercising or entitled to exercise any administrative, executive, judicial, legislative, police, regulatory or taxing authority or power; or
  - (c) Any court or governmental tribunal.
120. “Governmental Charges” has the meaning as set forth in Section 9.02.
121. “Green Attributes” means any and all credits, benefits, emissions reductions, offsets, and allowances, howsoever entitled, attributable to the generation from the Project,

and its avoided emission of pollutants. Green Attributes include but are not limited to Renewable Energy Credits, as well as:

- (1) Any avoided emission of pollutants to the air, soil or water such as sulfur oxides (SO<sub>x</sub>), nitrogen oxides (NO<sub>x</sub>), carbon monoxide (CO) and other pollutants;
- (2) Any avoided emissions of carbon dioxide (CO<sub>2</sub>), methane (CH<sub>4</sub>), nitrous oxide, hydrofluorocarbons, perfluorocarbons, sulfur hexafluoride and other greenhouse gases (GHGs) that have been determined by the United Nations Intergovernmental Panel on Climate Change, or otherwise by law, to contribute to the actual or potential threat of altering the Earth's climate by trapping heat in the atmosphere;<sup>1</sup>
- (3) The reporting rights to these avoided emissions, such as Green Tag Reporting Rights.

Green Tag Reporting Rights are the right of a Green Tag Purchaser to report the ownership of accumulated Green Tags in compliance with federal or state law, if applicable, and to a federal or state agency or any other party at the Green Tag Purchaser's discretion, and include without limitation those Green Tag Reporting Rights accruing under Section 1605(b) of The Energy Policy Act of 1992 and any present or future federal, state, or local law, regulation or bill, and international or foreign emissions trading program. Green Tags are accumulated on a MWh basis and one Green Tag represents the Green Attributes associated with one (1) MWh of energy.

Green Attributes do not include:

- (i) Any energy, capacity, reliability or other power attributes from the Project,
- (ii) Production tax credits associated with the construction or operation of the Project and other financial incentives in the form of credits, reductions, or allowances associated with the Project that are applicable to a state or federal income taxation obligation,
- (iii) Fuel-related subsidies or "tipping fees" that may be paid to Seller to accept certain fuels, or local subsidies received by the generator for the destruction of particular preexisting pollutants or the promotion of local environmental benefits, or
- (iv) Emission reduction credits encumbered or used by the Project for compliance with local, state, or federal operating and/or air quality permits.

---

<sup>1</sup> Avoided emissions may or may not have any value for GHG compliance purposes. Although avoided emissions are included in the list of Green Attributes, this inclusion does not create any right to use those avoided emissions to comply with any GHG regulatory program.



- If the Project is a biomass or biogas facility and Seller receives any tradable Green Attributes based on the greenhouse gas reduction benefits or other emission offsets attributed to its fuel usage, it shall provide Buyer with sufficient Green Attributes to ensure that there are zero net emissions associated with the production of electricity from the Project.
122. “Green Market Price” means the market price for energy and Green Attributes from an ERR.
  123. “Guarantor” means the business entity identified in Section 1.09 and acceptable to SCE.
  124. “Guaranty Agreement” means, if a Guarantor has been identified by Seller and accepted by SCE, the guaranty agreement from the Guarantor in the form attached hereto as Exhibit I.
  125. “Increment” means an Inverter Block Unit.
  126. “Indebtedness Agreements” has the meaning set forth in Section 6.01(c)(xv).
  127. “Indemnified Party” has the meaning set forth in Section 10.03(d).
  128. “Indemnitor” has the meaning set forth in Section 10.03(d).
  129. “Initial Synchronization” means the first generating unit of the Generating Facility is operating in parallel with Seller’s Transmission Provider and the first kWh of electric energy is measured by the CAISO Approved Meter or Check Meter.
  130. “Initial Synchronization Date” means the date upon which Initial Synchronization occurs.
  131. “Installed DC Rating” means, at any time, the sum of the Photovoltaic Module DC Ratings for all Photovoltaic Modules actually installed at the Site and verified by SCE pursuant to Exhibit L, expressed in kW<sub>PDC</sub>.
  132. “Interconnection Point” means the location set forth in Section 1.01(e) where the Generating Facility first interconnects with the existing electrical transmission or distribution system, as reported on the Generating Facility’s application for interconnection with the Transmission Provider’s electric system, and as may be more specifically described in the LGIA.
  133. “Interconnection Queue Position” is the order of Seller’s valid request for interconnection relative to all other valid interconnection requests, as specified in Section 1.11.
  134. “Interconnection Study” means any of the studies defined in the CAISO’s Tariff or any Transmission Provider’s tariff that reflect methodology and costs to interconnect the Generating Facility to the Transmission Provider’s electric grid.
  135. “Interest Rate” means, for any date:

- (a) The per annum rate of interest equal to the “Prime Rate” published in *The Wall Street Journal* under “Money Rates” or such date (or if not published on such date on the most recent preceding day on which published); plus
  - (b) Two percentage points (2%);
- provided*, in no event may the Interest Rate exceed the maximum interest rate permitted by Applicable Laws.
136. “Inverter Block Unit” means each Current Inverter installed on the Site as part of the Generating Facility, along with the associated DC Collection Systems and Photovoltaic Modules connected to such Current Inverter.
137. “Inverter Block Unit Capacity” means, with respect to each Inverter Block Unit, the total rated electric alternating current energy generating capacity of such Inverter Block Unit, determined as the lesser of:
- (a) The manufacturer’s output rating of the Current Inverter(s) included in such Inverter Block Unit, consistent with Prudent Electrical Practices and accepted industry standards, as indicated on the nameplate physically attached to such Current Inverter(s);
  - (b) The sum of the manufacturer’s nameplate ratings of all Photovoltaic Modules included in such Inverter Block Unit, consistent with Prudent Electrical Practices and accepted industry standards, as indicated on the nameplates physically attached to such individual Photovoltaic Modules; or
  - (c) The continuous power output rating at the expected operating power factor of the Inverter Block Unit’s medium voltage transformer.
138. “JAMS” has the meaning set forth in Article Twelve.
139. “kW” means a kilowatt of electric energy generating capacity.
140. “kWh” means a kilowatt-hour of electric energy.
141. “kW<sub>PDC</sub>” means peak DC power.
142. “Lease” means one or more agreements whereby Seller leases the real property of the Site described in Section 1.01(b) from a third party, the term of which lease begins on or before the commencement of construction of the Generating Facility and extends at least through the last day of the Term.
143. “Lender” means any financial institutions or successors in interest or assignees that provide(s) development, bridge, construction, permanent debt or tax equity financing or refinancing for the Generating Facility to Seller.
144. “Letter of Credit” means an irrevocable, nontransferable standby letter of credit, substantially in the form of Exhibit N and acceptable to SCE, provided by Seller from an issuer acceptable to SCE that is either a U.S. commercial bank or a U.S. branch of a foreign bank with the bank having a Credit Rating of at least (a) “A-” from S&P and Fitch, and “A3” from Moody’s, if such entity is rated by all three ratings

- agencies; or (b) “A-” from S&P or Fitch, or “A3” from Moody’s, if such entity is rated by only one or two of the ratings agencies.
145. “Letter of Credit Default” means with respect to a Letter of Credit, the occurrence of any of the following events:
- (a) The issuer of the Letter of Credit fails to comply with or perform its obligations under such Letter of Credit;
  - (b) The issuer of the Letter of Credit disaffirms, disclaims, repudiates or rejects, in whole or in part, or challenges the validity of, the Letter of Credit;
  - (c) The Letter of Credit fails or ceases to be in full force and effect at any time;
  - (d) Seller fails to provide an extended or replacement Letter of Credit within twenty (20) Business Days before the Letter of Credit expires or terminates; or
  - (e) The issuer of the Letter of Credit becomes Bankrupt;
- provided*, no Letter of Credit Default will occur or be continuing in any event with respect to a Letter of Credit after the time such Letter of Credit is required to be canceled or returned to a Party in accordance with the terms of this Agreement.
146. “Letter of Credit Derating” means the issuer of a Letter of Credit fails to maintain a Credit Rating of at least “A-” by S&P and Fitch and “A3” by Moody’s,
147. “LF” means a number that is a representation for all net electric energy losses or avoided losses, as filed by the Transmission Provider at FERC or determined by the CAISO associated with the transmission of electric energy through the electric system from the high voltage side of the Generating Facility’s substation bus bar to the interface with the CAISO Controlled Grid.
148. “LGIA” means the interconnection agreement described and required in Section 2.02(b), as entered into by and between Seller and the applicable Transmission Provider.
149. “Licensed Professional Engineer” means a person proposed by Seller and acceptable to SCE in its reasonable judgment who (a) is employed by a nationally recognized independent third party engineering firm, (b) is licensed to practice engineering in the State of California, (c) has substantive training and at least five (5) years’ experience in the power industry specific to the technology of the Project, and (d) is licensed in an appropriate engineering discipline for the required certification being made.
150. “Local Business Day” means a Business Day on which commercial banks are open for business in relation to any:
- (a) Payment, in the place where the relevant account is located; and
  - (b) Notice or other communication, in the location specified in the address for notice provided by the recipient, except for the Friday immediately following the U.S. Thanksgiving holiday or a Federal Reserve Bank holiday.

151. “Locational Marginal Price” has the meaning set forth in the CAISO Tariff.
152. “Losses” means, with respect to any Party, an amount equal to the present value of the economic loss to it, if any (exclusive of Costs), resulting from termination of this Agreement for the remaining Term of this Agreement, determined in a commercially reasonable manner.

Factors used in determining economic loss to a Party may include, without limitation, reference to information supplied by one or more third parties, which shall exclude Affiliates of the Non-Defaulting Party, including without limitation, quotations (either firm or indicative) of relevant rates, prices, yields, yield curves, volatilities, spreads or other relevant market data in the relevant markets, comparable transactions, forward price curves based on economic analysis of the relevant markets, settlement prices for comparable transactions at liquid trading hubs (e.g., NYMEX), all of which should be calculated for the remaining Term of this Agreement and must include the value of Green Attributes, Capacity Attributes and Resource Adequacy Benefits and the value of all Banked Curtailed Energy for all Terms Years, or portions thereof, prior to termination of this Agreement.

Only if the Non-Defaulting Party is unable, after using commercially reasonable efforts, to obtain third party information to determine the loss of economic benefits, then the Non-Defaulting Party may use information available to it internally suitable for these purposes in accordance with prudent industry practices.

153. “Lost Output” means the reduction in Metered Amounts over the relevant measurement period that the Generating Facility was available to produce and could reasonably have been expected to deliver, based upon the calculation method set forth in Exhibit M, but was not delivered due to a Lost Output Event.
154. “Lost Output Event” means any of the following occurrences which cause Seller to be unable to deliver energy:
- (a) Force Majeure;
  - (b) An Event of Default where SCE is the Defaulting Party; or
  - (c) A curtailment or reduction of deliveries in accordance with Section 3.12(f) (including a curtailment that produces Curtailed Product) or as otherwise ordered or caused by the CAISO or the Transmission Provider (including without limitation a curtailment or reduction that does not constitute a Force Majeure as provided in subparagraph (f) of the definition of Force Majeure); or
  - (d) An Emergency, to the extent not already covered in item (c) above.
155. “Lost Output Report” means the monthly report of Lost Output in the form of the worksheet from the Lost Output Workbook prepared in accordance with the procedures set forth in Section 3.23 and Exhibit M.
156. “Lost Output Workbook” has the meaning set forth in Exhibit M.

*The contents of this document are subject to restrictions on disclosure as set forth herein.*

157. “Market Price Referent” means the market price referent applicable to this Agreement, as determined by the CPUC in accordance with Public Utilities Code Section 399.15(c).
158. “Material Permits” means all permits required for Commercial Operation of the Generating Facility, as set forth on Exhibits G-1 and G-2.
159. “Mediator” has the meaning set forth in Article Twelve.
160. “Meteorological Equipment” means the instruments and equipment that meet those specifications set forth in Exhibit T and are compatible with the requirements of Exhibit M, as such exhibits may be modified by SCE from time to time to reflect the CAISO’s PIRP protocol and the requirements of SCE.
161. “Metered Amounts” means the total quantity of electric energy produced by the Generating Facility and expressed in kWh, as recorded by the CAISO-Approved Meter(s), or Check Meter(s), as applicable, adjusted for losses to the Delivery Point.
162. “Milestone Amount” has the meaning set forth in Section 3.06(d)(ii).
163. “Milestone Schedule” means Seller’s schedule to develop the Generating Facility as set forth in Exhibit G-1, including any revisions thereto in accordance with this Agreement.
164. “Moody’s” means Moody’s Investor Services, Inc.
165. “MRTU” means the Market Redesign and Technology Upgrade first implemented by CAISO in April 2009.
166. “MW” means a megawatt (or 1,000 kilowatts) of electric energy generating capacity.
167. “MWh” means a megawatt-hour (or 1,000 kilowatt-hours) of electric energy.
168. “NERC” means the North American Electric Reliability Corporation.
169. “NERC Reliability Standards” means those reliability standards applicable to the Generating Facility, or to the Generator Owner or the Generator Operator with respect to the Generating Facility, that are adopted by NERC and approved by the applicable regulatory authorities and available on the NERC website.
170. “NERC Standards Non-Compliance Penalties” means any and all monetary fines, penalties, damages, interest or assessments by the NERC, CAISO, WECC, a Governmental Authority or any entity acting at the direction of a Governmental Authority arising from or relating to a failure to perform the obligations of Generator Operator or Generator Owner as set forth in the NERC Reliability Standards.
171. “No Fault Transmission Delay” means a delay in construction or installation of:
- 1) The transmission upgrades necessary to obtain Full Capacity Deliverability Status; or
  - 2) The 230/500 kV Whirlwind Substation that is to be built as part of SCE’s Tehachapi renewable transmission project associated with Solar Star California XX,

*The contents of this document are subject to restrictions on disclosure as set forth herein.*

- LLC for more than sixty (60) days beyond the furthest date for completion given in the LGIA.
172. “Non-Availability Charges” has the meaning set forth in the CAISO Tariff.
173. “Non-Defaulting Party” has the meaning set forth in Section 6.02.
174. “Non-Disclosure Agreement” has the meaning set forth in Section 10.10(b)(i).
175. “Notice” means notices, requests, statements or payments provided in accordance with Section 10.08 and Exhibit C.
176. “Notice of Non-Renewal” has the meaning set forth in Section 8.02(b)(iv).
177. “Notice of Completed Installation” means a Notice from Seller to SCE describing (with reference to Exhibit B-1) the portion of the Generating Facility Capacity installed as of the immediately prior month and specifying the Increment of Contract Capacity attributable to this portion of the Generating Facility.
178. “Notice of Planned Installation” means a Notice from Seller to SCE describing the portion of the Generating Facility Capacity that Seller plans to install during the next month and specifying the Increment of Contract Capacity attributable to this portion of the Generating Facility; *provided* that in the case of the first such Notice delivered hereunder pursuant to Section 3.14, such Notice shall describe the entire portion of the Generating Facility Seller plans to have installed through the end of the next month.
179. “OMAR” means the Operational Metering Analysis and Reporting System operated and maintained by the CAISO as the repository of settlement quality meter data or its successor.
180. “Operate,” “Operated”, “Operating” or “Operation” means to provide (or the provision of) all the operation, engineering, purchasing, repair, supervision, training, inspection, testing, protection, use, management, improvement, replacement, refurbishment, retirement, and maintenance activities associated with operating the Generating Facility in accordance with Prudent Electrical Practices.
181. “Original Term” has the meaning set forth in Section 1.06(a).
182. “Outage Schedule” has the meaning set forth in Section 3.16.
183. “Over-Schedule Generation Curtailment Order” or “OSGC Order” has the meaning set forth in Section 4.02(a)(ii).
184. “Over-Schedule Generation Curtailment Quantity” or “OSGC Quantity” has the meaning set forth in Section 4.02(a)(ii).
185. “Participating Intermittent Resource” means an intermittent resource generating facility that is certified, and remains certified, under PIRP as set forth in the CAISO Tariff.

186. “Participating Intermittent Resource Program” or “PIRP” means the CAISO’s intermittent resource program initially established pursuant to Amendment No. 42 of the CAISO Tariff in Docket No. ER02-922-000 or any successor program that SCE determines accomplishes a similar purpose.
187. “Party” or “Parties” have the meaning set forth in the Preamble.
188. “Payment Invoices” are invoices issued by Seller during the Startup Period and Delivery Term detailing amounts owed by SCE to Seller or by Seller to SCE for energy deliveries, CAISO Revenues, CAISO Costs, CAISO Sanctions, SCE Penalties and other charges and adjustments as may be owed by the Parties, in accordance with Exhibit E.
189. “Performance Assurance” means collateral (in the amount of the Performance Assurance Amount set forth in Section 1.08) for Seller’s performance under this Agreement in the form of cash, Letter(s) of Credit, or guaranty acceptable to SCE.
190. “Performance Assurance Amount” means the collateral amount for Performance Assurance set forth in Section 1.08.
191. “Performance Tolerance Band” has the meaning set forth in Exhibit Q.
192. “Permit Adjusted Contract Capacity” means the greater of 221 MW or the Actual Authorized Capacity, but in no event greater than 276 MW.
193. “Permit Approval” means approval by the relevant regulatory agencies of any Permit and shall be deemed obtained upon the issuance of such Permit, and shall not be invalidated by the pendency of an appeal or other post-issuance challenge to the issuance of the Permit.
194. “Permit Capacity Reduction Amount” has the meaning set forth in Section 3.06(h)(i).
195. “Permits” means all applications, approvals, authorizations, consents, filings, licenses, orders, permits or similar requirements imposed by any Governmental Authority, or the CAISO, in order to develop, construct, Operate, maintain, improve, refurbish and retire the Generating Facility or to Forecast or deliver the electric energy produced by the Generating Facility to SCE.
196. “Permitted Transferee” means any entity that:
  - (a) Has, or has a parent that has, a tangible net worth of not less than four hundred fifty million dollars (\$450,000,000.00)
  - (b) Has, or has a parent that has, a Credit Rating of at least BBB from either S&P or Fitch, or Baa2 from Moody’s; and
  - (c) Has:
    - i) at least five (5) years of experience in the operation and ownership of similar solar power generation facilities;

- ii) retained a reputable third party with at least five (5) years of experience in the operation of similar solar power generation facilities to operate and maintain the Generating Facility; or
  - iii) demonstrated to SCE's sole satisfaction that it has the ability to fully comply with all of Seller's obligations under the Agreement.
197. "Photovoltaic Module" means the individual module or component that produces DC electric energy from sun light.
198. "Photovoltaic Module DC Rating" means, for each Photovoltaic Module installed or to be installed at the Site the number (expressed in kW<sub>PDC</sub>) stated on the nameplate affixed thereto representing the manufacturer's maximum (at "peak" sunlight) DC power rating at the standard test condition ("P<sub>mp</sub>" or Power maximum at peak).
199. "PNode" has the meaning set forth in the CAISO Tariff.
200. "Potential Event of Default" means any event which, with the giving of Notice or the lapse of time or both, would constitute an Event of Default.
201. "Price Taker" has the meaning set forth in the CAISO Tariff.
202. "Product" has the meaning set forth in Section 1.01(d).
203. "Product Payment" means the monthly payment by SCE in accordance with Exhibit E for Product delivered to SCE throughout the Delivery Term in accordance with the terms of this Agreement.
204. "Product Payment Allocation Factor" has the meaning set forth in Exhibit K.
205. "Product Price" means the price set forth in Section 1.07.
206. "Product Replacement Damage Amount" has the meaning set forth in Section 3.07(b)(i).
207. "Project" means the Generating Facility.
208. "Prudent Electrical Practices" means those practices, methods and acts that would be implemented and followed by prudent operators of electric energy generating facilities in the Western United States, similar to the Generating Facility, during the relevant time period, which practices, methods and acts, in the exercise of prudent and responsible professional judgment in the light of the facts known at the time the decision was made, could reasonably have been expected to accomplish the desired result consistent with good business practices, reliability and safety.

Prudent Electrical Practices shall include, at a minimum, those professionally responsible practices, methods and acts described in the preceding sentence that comply with manufacturers' warranties, restrictions in this Agreement, and the requirements of Governmental Authorities, WECC standards, the CAISO and Applicable Laws.

Prudent Electrical Practices also includes taking reasonable steps to ensure that:

*The contents of this document are subject to restrictions on disclosure as set forth herein.*



- (a) Equipment, materials, resources, and supplies, including spare parts inventories, are available to meet the Generating Facility's needs;
  - (b) Sufficient Operating personnel are available at all times and are adequately experienced and trained and licensed as necessary to Operate the Generating Facility properly and efficiently, and are capable of responding to reasonably foreseeable emergency conditions at the Generating Facility and Emergencies whether caused by events on or off the Site;
  - (c) Preventive, routine, and non-routine maintenance and repairs are performed on a basis that ensures reliable, long term and safe Operation of the Generating Facility, and are performed by knowledgeable, trained, and experienced personnel utilizing proper equipment and tools;
  - (d) Appropriate monitoring and testing are performed to ensure equipment is functioning as designed;
  - (e) Equipment is not Operated in a reckless manner, in violation of manufacturer's guidelines or in a manner unsafe to workers, the general public, or the Transmission Provider's electric system or contrary to environmental laws, permits or regulations or without regard to defined limitations such as, flood conditions, safety inspection requirements, operating voltage, current, volt ampere reactive (VAR) loading, frequency, rotational speed, polarity, synchronization, and control system limits; and
  - (f) Equipment and components are designed and manufactured to meet or exceed the standard of durability that is generally used for electric energy generating facilities operating in the Western United States and will function properly over the full range of ambient temperature and weather conditions reasonably expected to occur at the Site and under both normal and emergency conditions.
209. "Qualified Amounts" means the Metered Amounts, expressed in kWh, that qualify as renewable power under the requirements of the California Renewables Portfolio Standard, *provided*, if a change in RPS Legislation occurring after the Effective Date is the sole cause of Metered Amounts no longer qualifying as renewable power under the requirements of the California Renewables Portfolio Standard, then Qualified Amounts shall mean Metered Amounts if Seller has used commercially reasonable efforts (consistent with and subject to the Compliance Expenditure Cap and the obligations under Section 1.10(a)) to comply with such change in law.
210. "RAP ID" means the contract identification number set forth on the title page to this Agreement.
211. "Real-Time Availability" means Seller's cumulative available capacity of the Generating Facility on a real-time basis.
212. "Real-Time Market" has the meaning set forth in the CAISO Tariff.

213. “Real-Time Over-Schedule Generation Curtailment Order” or “RTOSGC Order” has the meaning set forth in Section 4.02(d)(ii).
214. “Real-Time Over-Schedule Generation Curtailment Quantity” or “RTOSGC Quantity” has the meaning set forth in Section 4.02(d)(ii).
215. “Real-Time Price” means the CAISO Real-Time Market Locational Marginal Price for electric energy in each applicable Settlement Interval (including the energy, congestion and losses components) at the Generating Facility’s PNode (as published by the CAISO) which is the pricing point used by the CAISO for settlements of this Generating Facility.
216. “Reduced Capacity Authority to Construct” has the meaning set forth in Section 1.01(h)(i).
217. “Renewable Energy Credit” or “REC” has the meaning set forth in CPUC Decision D.08-08-028, as such definition may be modified by the CPUC or Applicable Law from time to time.
218. “Required Material” means any permit, license, application, certification, design, specification, program, agreement, instrument, equipment, device, mechanism, or any other item in connection with the Generating Facility to be reviewed or approved by SCE or on SCE’s behalf, or requested or required of Seller by SCE or on SCE’s behalf, under this Agreement.
219. “Resource Adequacy Benefits” means the rights and privileges attached to the Generating Facility that satisfy any entity’s resource adequacy obligations, as those obligations are set forth in any Resource Adequacy Rulings and shall include any local, zonal or otherwise locational attributes associated with the Generating Facility.
220. “Resource Adequacy Rulings” means CPUC Decisions 04-01-050, 04-10-035, 05-10-042, 06-06-064, 06-07-031 and any other CPUC ruling or decision, or any other resource adequacy laws, rules or regulations enacted, adopted or promulgated by any applicable Governmental Authority, as such CPUC decisions, rulings, laws, rules or regulations may be amended or modified from time-to-time throughout the Delivery Term.
221. “Responsible Officer” means the chief financial officer, treasurer or any assistant treasurer of a Party or its Guarantor or any employee of a Party or its Guarantor designated by any of the foregoing.
222. “Restricted Period” has the meaning set forth in Section 2.06(b).
223. “RPS Legislation” means the State of California Renewable Portfolio Standard Program, as codified at California Public Utilities Code Section 399.11, *et seq.*
224. “S&P” means the Standard & Poor’s Rating Group.
225. “SCADA” means Supervisory Control and Data Acquisition, as defined by the CAISO Tariff.

226. “SCE” has the meaning set forth in the Preamble.
227. “SCE Penalty” means the amount charged to Seller by SCE, in accordance with Exhibit Q, for hours in a calendar month when Seller does not accurately provide the Forecast information as set forth in Exhibit D.
228. “Schedule,” “Scheduled” or “Scheduling” means the action of SCE in submitting Bids to the CAISO and receiving all CAISO Markets results from the CAISO; *provided*, that with respect to any Settlement Interval, a CAISO Market result where the Generating Facility is instructed to deliver zero (0) MWh is not considered a “Schedule” for purposes of this Agreement.
229. “Scheduling Coordinator” or “SC” means an entity certified by the CAISO for the purposes of undertaking the functions specified by CAISO Tariff Section 2.2.6.
230. “SEC” means the Securities and Exchange Commission.
231. “Section 1603” means Section 1603 of Public Law 111- 5 (2009) (American Recovery and Reinvestment Act of 2009), as amended from time to time.
232. “Security Interest” has the meaning set forth in Section 8.03.
233. “Seller” has the meaning set forth in the Preamble.
234. “Seller’s Debt” means, without duplication, each of the following:
- (a) All indebtedness of Seller for borrowed money;
  - (b) All obligations of Seller for the deferred purchase price of property or services which purchase price is due more than six months after the date of placing such property in service or taking delivery or title thereto or the completion of such services (other than trade payables not overdue by more than ninety (90) days incurred in the ordinary course of Seller’s business);
  - (c) All obligations of Seller evidenced by notes, bonds, debentures, Disqualified Stock or other similar instruments;
  - (d) All obligations of Seller created or arising under any conditional sale or other title retention agreement with respect to property acquired by Seller (even though the rights and remedies of the seller or lender under such agreement in the event of default are limited to repossession or sale of such property);
  - (e) All monetary obligations of Seller under:
    - i) A lease of any property (whether real, personal or mixed) by Seller as lessee that, in conformity with GAAP, is accounted for as a capital lease on the balance sheet of Seller;
    - ii) A so-called synthetic, off-balance sheet or tax retention lease; or
    - iii) An agreement for the use or possession of property creating obligations which do not appear on the balance sheet of Seller but which, upon the insolvency or bankruptcy of Seller, would be

characterized as indebtedness of Seller (without regard to accounting treatment);

- (f) All obligations, contingent or otherwise, of Seller under acceptance, letter of guaranty, letter of credit or similar facilities;
- (g) All obligations of Seller with respect to any redeemable equity interests in Seller, including in the case of preferred stock at the greater of the voluntary or involuntary liquidation preference plus accrued and unpaid dividends;
- (h) All obligations of Seller with respect to any swaps, caps or collar agreements or similar arrangements to hedge against fluctuations in interest rates or currency exchange rates or the exchange of nominal interest obligations, either generally or under specific contingencies, in each case, valued at the aggregate net mark-to-market value;
- (i) All indebtedness of others referred to in clauses (a) through (h) above guaranteed by Seller, or in effect guaranteed by Seller through an agreement:
  - i) To pay or purchase such indebtedness or to advance or supply funds for the payment or purchase of such indebtedness;
  - ii) To purchase, sell or lease (as lessee or lessor) property, or to purchase or sell services, primarily for the purpose of enabling the debtor to make payment of the indebtedness or to assure the holder of such indebtedness against loss;
  - iii) To supply funds to or invest in the debtor (including any agreement to pay for property or services irrespective of whether such property is received or such services are rendered); or
  - iv) Otherwise to assure a creditor against loss; and
- (j) Without duplication of the foregoing, all indebtedness referred to in clauses (a) through (i) above secured by any lien on property (including accounts and contract rights) owned by Seller.

The outstanding amount of indebtedness as described above at any date will be the outstanding balance at such date of all unconditional obligations as described above and, with respect to contingent obligations as described above, the maximum liability upon the occurrence of the contingency giving rise to the obligation.

Notwithstanding the foregoing, the term “Seller’s Debt” as used herein does not include Seller’s obligations under this Agreement and the Lease (provided that such Lease does not constitute an obligation of Seller described in clause (e) of the first sentence of this definition).

235. “Seller’s Energy Delivery Obligation” has the meaning set forth in Section 3.07(a)(i).

236. “Settlement Interval” means any one of the six ten (10) minute time intervals beginning on any hour and ending on the next hour (e.g. 12:00 to 12:10, 12:10 to 12:20, etc.).
237. “Settlement Interval Actual Available Capacity” means the sum of the capacity, in MWs, of all Current Inverters of the Generating Facility that were available at the end of the Settlement Interval, as indicated by the Actual Availability Report.
238. “Simple Interest Payment” means a dollar amount calculated by multiplying the:
- (a) Dollar amount on which the Simple Interest Payment is based; times
  - (b) Federal Funds Effective Rate or Interest Rate, as applicable; times
  - (c) The result of dividing the number of days in the calculation period by 360.
239. “Site” means the real property on which the Generating Facility is, or will be located, as further described in Section 1.01(b) and Exhibit B-1.
240. “Site Control” means that Seller shall:
- (a) Own the Site;
  - (b) Be the lessee of the Site under a Lease;
  - (c) Be the holder of a right-of-way grant or similar instrument with respect to the Site; or
  - (d) Be the managing partner or other person or entity authorized to act in all matters relating to the control and Operation of the Site and the Generating Facility.
241. “Solar Resource Evaluation Report” means a final report concerning the electric energy producing potential of the Site prepared by an independent engineer that assesses the solar resource potential at the Site.
242. “Startup Period” means the period that begins at Initial Synchronization and ends at Commercial Operation Date.
243. “Station Use” means:
- (a) The electric energy produced by the Generating Facility that is used within the Generating Facility to power the lights, motors, control systems and other electrical loads that are necessary for Operation; and
  - (b) The electric energy produced by the Generating Facility that is consumed within the Generating Facility’s electric energy distribution system as losses.
244. “Supplemental Lost Output” has the meaning set forth in Section 3.23(b).
245. “Supplemental Lost Output Report” has the meaning set forth in Section 3.23(b).

246. “Telemetry System” means a system of electronic components that interconnects the CAISO, the Generating Facility, and the GMS in accordance with the CAISO’s requirements and other applicable requirements as set forth in Section 3.08(e).
247. “Term” means the term of this Agreement as set forth in Section 1.06.
248. “Term Year” means a twelve (12) month period beginning on the first day of the calendar month following the Firm Operation Date and each successive twelve (12) month period thereafter.
249. “Termination Payment” means the sum of all amounts owed by the Defaulting Party to the Non-Defaulting Party under this Agreement, less any amounts owed by the Non-Defaulting Party to the Defaulting Party determined as of the Early Termination Date.
250. “TOD Period(s)” means the time of delivery period(s) set forth in Exhibit K.
251. “TOD Period Product Payment” means a portion of a Product Payment based upon the time of delivery of Product and calculated in accordance with the formulas set forth in Exhibit E.
252. “Trading Day” has the meaning set forth in the CAISO Tariff.
253. “Transmission Provider” means any entity or entities responsible for the interconnection of the Generating Facility with a Control Area or transmitting the Metered Amounts on behalf of Seller from the Generating Facility to the Delivery Point.
254. “Unawarded Energy” is the Forecast-Derived Energy in any hour of the applicable Trading Day for which hour no Schedule has been awarded in the Day-Ahead Market.
255. “Unincluded Capacity” has the meaning set forth in Section 3.06(g)(ii).
256. “Web Client” means a web-based system approved by SCE.
257. “WECC” means the Western Electricity Coordinating Council, the regional reliability council for the Western United States, Northwestern Mexico and Southwestern Canada.
258. “WREGIS” means the Western Renewable Energy Generation Information System or successor entity.

---

\*\*\* End of EXHIBIT A \*\*\*

## **EXHIBIT B-1**

### *Generating Facility and Site Description*

#### 1. Generating Facility Description.

- a. Project Company: Solar Star California XX, LLC
- b. Technology Type: Solar Photovoltaic
- c. System size:
  - i. DC System Size: 350.064MWp (DC)
  - ii. AC Inverter Nameplate Capacity: 286MW (AC)
  - iii. AC System Size at Collection Point: 276MW (AC)
- d. Generating Facility Equipment, Systems, Control Systems and Features
  - i. 823,680 425W SunPower photovoltaic modules
  - ii. 1144 single-axis SunPower T0 tracker units made up of structural steel, drive motors, components (nuts, bolts, clamps, etc)
  - iii. DC Cabling and junction boxes
  - iv. 572 500kW Inverters on 276 equipment pads
  - v. 286 Transformers (step up to 34.5kV)
  - vi. AC Cabling
  - vii. Switchgear and substations
  - viii. Met stations
  - ix. 1 216 MVA Transformer (step up to 230kV)
  - x. 1 70 MVA Transformer (step up to 230kV)
  - xi. Data Acquisition System
  - xii. Interconnection Switching Station
- e. One-Line Diagram included in Exhibit B-2

*The contents of this document are subject to restrictions on disclosure as set forth herein.*

*RAP ID# 5413, Solar Star California XX*

- f. Site Plan Drawing (AVSP II – 276 MW’s Project T408 outlined in blue dashed lines).

---

*The contents of this document are subject to restrictions on disclosure as set forth herein.*



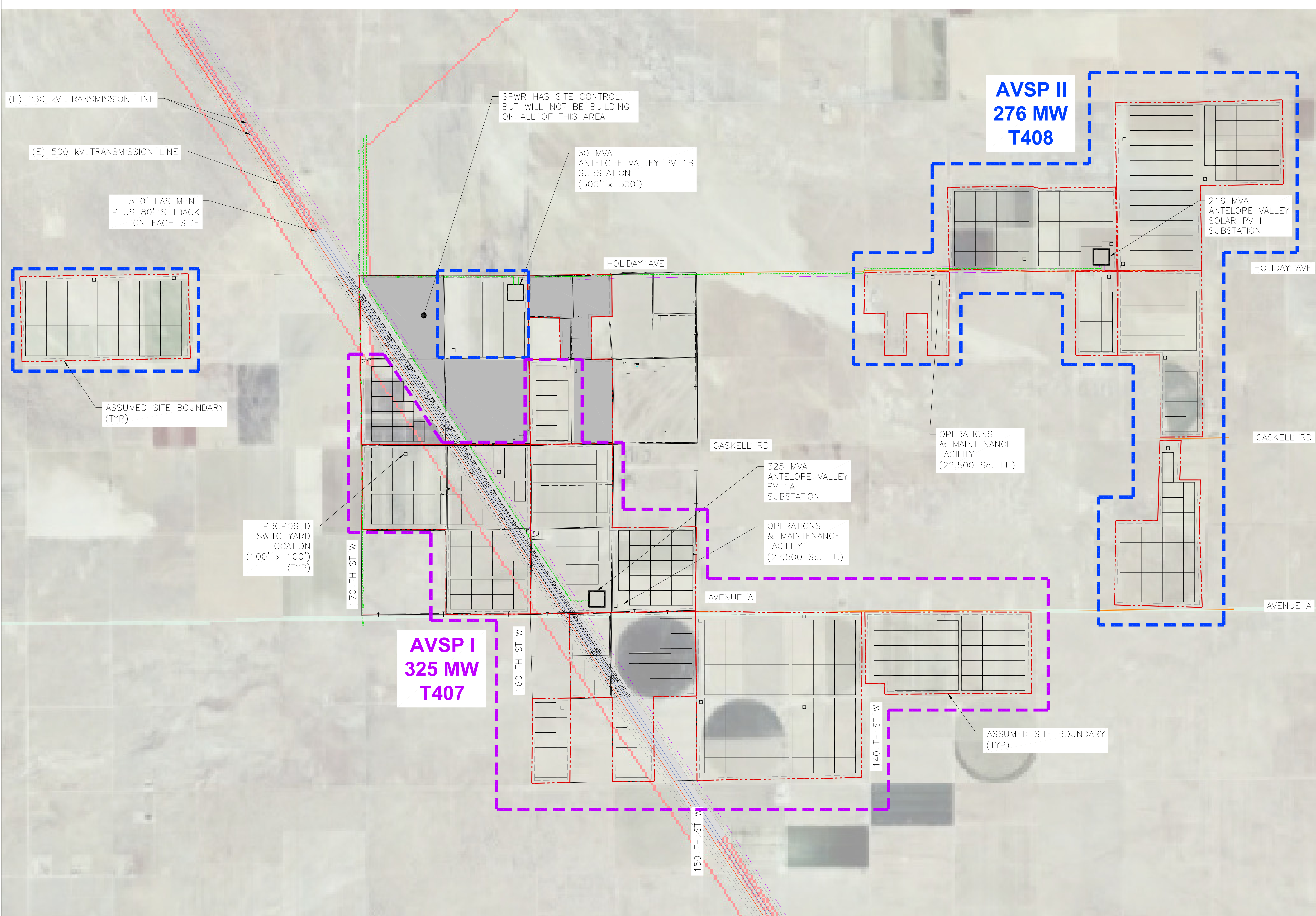

(E) 230 kV TRANSMISSION LINE

(E) 500 kV TRANSMISSION LINE

510' EASEMENT PLUS 80' SETBACK ON EACH SIDE

SPWR HAS SITE CONTROL, BUT WILL NOT BE BUILDING ON ALL OF THIS AREA

60 MVA ANTELOPE VALLEY PV 1B SUBSTATION (500' x 500')

**AVSP II  
276 MW  
T408**

216 MVA ANTELOPE VALLEY SOLAR PV II SUBSTATION

ASSUMED SITE BOUNDARY (TYP)

PROPOSED SWITCHYARD LOCATION (100' x 100') (TYP)

**AVSP I  
325 MW  
T407**

HOLIDAY AVE

HOLIDAY AVE

GASKELL RD

GASKELL RD

325 MVA ANTELOPE VALLEY PV 1A SUBSTATION

OPERATIONS & MAINTENANCE FACILITY (22,500 Sq. Ft.)

OPERATIONS & MAINTENANCE FACILITY (22,500 Sq. Ft.)

AVENUE A

AVENUE A

170 TH ST W

160 TH ST W

140 TH ST W

150 TH ST W

ASSUMED SITE BOUNDARY (TYP)

**PROPOSED AVSP I SYSTEM SPECIFICATIONS:**

397,800.00 kWp ≈ 325.00 MWac  
(936,000) HIGH EFF. (425W) MODULES  
10 MODULES/STRING, 93,600 STRINGS  
GCR=0.4  
AZIMUTH ANGLE: 0°

**PROPOSED AVSP II SYSTEM SPECIFICATIONS:**

337,824.00 kWp ≈ 276.00 MWac  
(794,880) HIGH EFF. (425W) MODULES  
10 MODULES/STRING, 79,488 STRINGS  
GCR=0.4  
AZIMUTH ANGLE: 0°



**1** ARRAY LAYOUT  
SCALE: 1"=1500'-0"

**NOTES:**

- 1. ARRAY SHOWN ON AERIAL IMAGE AND CUSTOMER PROVIDED PARCEL MAP

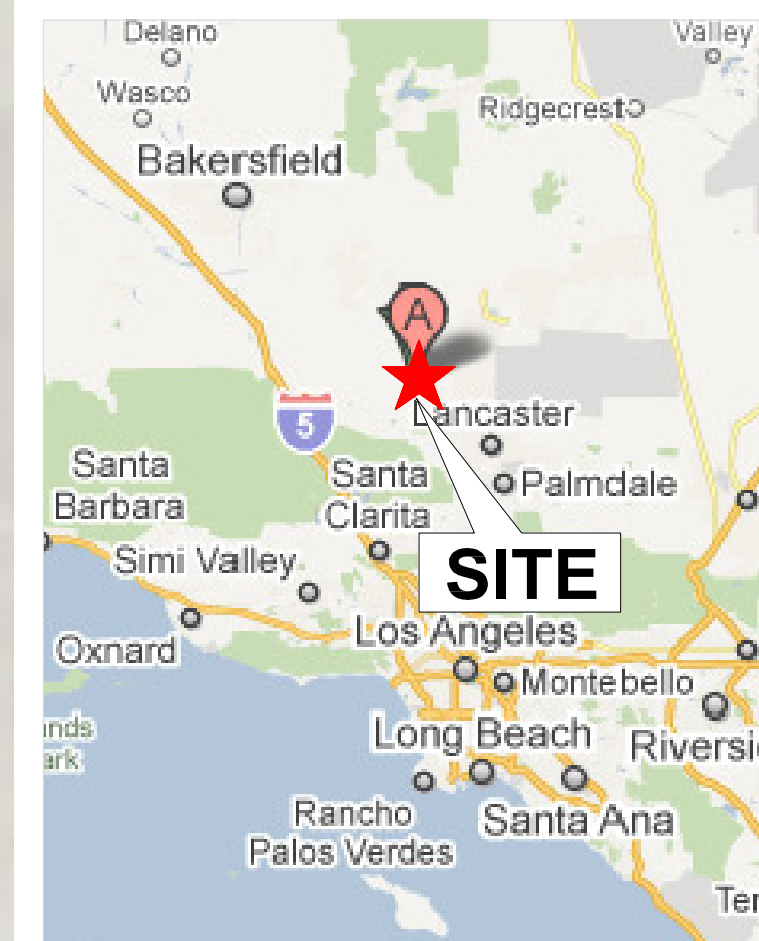

VICINITY MAP:

LATITUDE: 34.836461°

LONGITUDE: -118.427535°

**SUNPOWER**

1414 HARBOUR WAY SOUTH  
RICHMOND, CA 94804 USA  
(510) 540-0550

THIS DOCUMENT CONTAINS PROPRIETARY INFORMATION. REPRODUCTION, REPRODUCTION, REPRODUCTION, REPRODUCTION, REPRODUCTION IS STRICTLY PROHIBITED.

ENGINEER'S STAMP

ANTELOPE VALLEY  
SITE PLAN

EXHIBIT L  
ARRAY LAYOUT

REV	DESIGN #	DATE	DB	CB	DESCRIPTION
I	D-0010511	11-08-10	ZZ	JAC	SOLAR EXCLUSION ZONE-CUSTOMER
J	D-0010511.1	11-23-10	ZZ	-	PROPOSED 230 kV LINE EASEMENT
K	D-0011177	12-01-10	ZZ	JAC	NEW SITE PLAN AND BB'S
L	D-0011282	12-06-10	ZZ	JAC	TEXT MODIFICATIONS

OPPORTUNITY	003739
PROJECT	
DATE DRAWN	07/01/10
DRAWN BY	Z. ZORAN

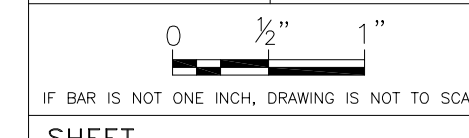

IF BAR IS NOT ONE INCH, DRAWING IS NOT TO SCALE

SHEET

1

2. Site Description.

a. Site

- i. Site is located in Kern County at 125<sup>th</sup> St W and Holiday Ave in Rosamond, CA, 93560

- ii. Site Map of the project as follows.

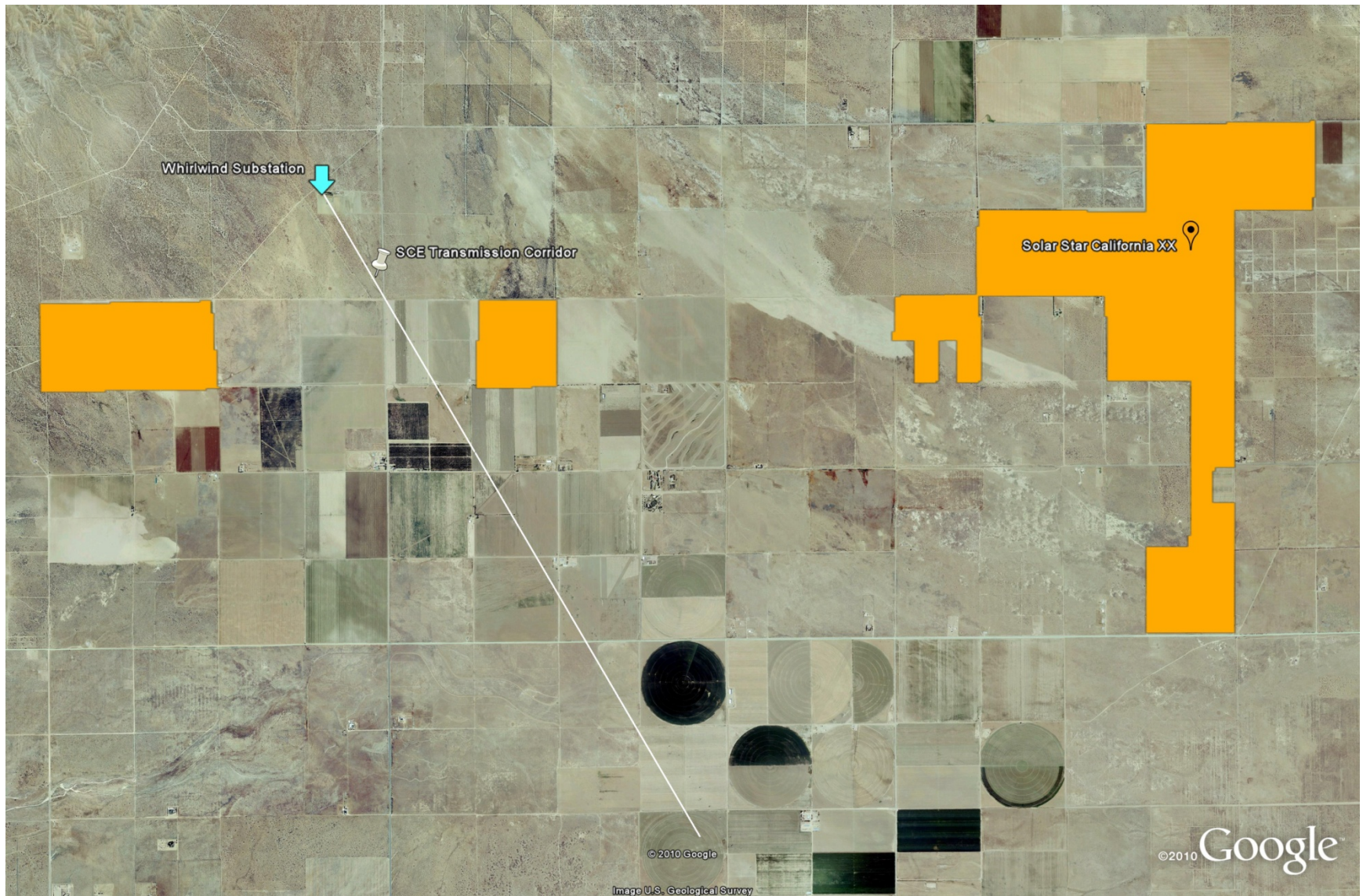

- b. Legal Description of Land as follows.

EXHIBIT A  
DESCRIPTION OF LAND

AVWS Kern County

THE LAND REFERRED TO HEREIN BELOW IS SITUATED IN THE UNINCORPORATED AREA, COUNTY OF KERN, STATE OF CALIFORNIA AND IS DESCRIBED AS FOLLOWS:

**PARCEL 1: APN 261-196-02 (PORTION)**

THE NORTH HALF OF THE NORTHWEST QUARTER OF SECTION 36, TOWNSHIP 9 NORTH, RANGE 15 WEST, MOUNT SAN BERNARDINO BASE AND MERIDIAN, AS PER THE OFFICIAL PLAT THEREOF.

EXCEPT 20% OF ALL OIL, MINERAL AND NATURAL GAS RIGHTS IN AND UNDER SAID LAND, AS RESERVED IN THE GRANT DEED FROM DANIEL WALTER KLEINHANS, JR., RECORDED NOVEMBER 21, 1957 IN BOOK 2871, PAGE 422 OF OFFICIAL RECORDS.

ALSO EXCEPTING AND RESERVING AN UNDIVIDED ONE-HALF OF ANY AND ALL GROUNDWATER RIGHTS ASSOCIATED WITH THE PROPERTY THAT MAY BE FINALLY DETERMINED OR ADJUDICATED IN THE COORDINATION PROCEEDING KNOWN AS THE "ANTELOPE VALLEY GROUNDWATER CASES", BEING JUDICIAL COUNCIL COORDINATION PROCEEDING NO. 4408(3), AS RESERVED IN DEED RECORDED NOVEMBER 5, 2007 AS INSTRUMENT NO. 0207220993 OF OFFICIAL RECORDS.

**PARCEL 2: APN 261-196-02 (PORTION)**

THE SOUTHEAST QUARTER OF THE NORTHEAST QUARTER OF SECTION 36, TOWNSHIP 9 NORTH, RANGE 15 WEST, MOUNT SAN BERNARDINO BASE AND MERIDIAN, AS PER THE OFFICIAL PLAT THEREOF.

EXCEPT 20% OF ALL OIL, MINERAL AND NATURAL GAS RIGHTS IN AND UNDER SAID LAND, AS RESERVED IN THE GRANT DEED FROM DANIEL WALTER KLEINHANS, JR., RECORDED NOVEMBER 21, 1957 IN BOOK 2871, PAGE 429 OF OFFICIAL RECORDS.

ALSO EXCEPTING AND RESERVING AN UNDIVIDED ONE-HALF OF ANY AND ALL GROUNDWATER RIGHTS ASSOCIATED WITH THE PROPERTY THAT MAY BE FINALLY DETERMINED OR ADJUDICATED IN THE COORDINATION PROCEEDING KNOWN AS THE "ANTELOPE VALLEY GROUNDWATER CASES", BEING JUDICIAL COUNCIL COORDINATION PROCEEDING NO. 4408(3), AS RESERVED IN DEED RECORDED NOVEMBER 5, 2007 AS INSTRUMENT NO. 0207220993 OF OFFICIAL RECORDS.

**PARCEL 3: APN 261-196-02 (PORTION)**

THE NORTH HALF OF THE NORTHEAST QUARTER OF SECTION 36, TOWNSHIP 9 NORTH, RANGE 15 WEST, MOUNT SAN BERNARDINO BASE AND MERIDIAN, AS PER THE OFFICIAL PLAT THEREOF.

EXCEPT 20% OF ALL OIL, MINERAL AND NATURAL GAS RIGHTS IN AND UNDER SAID LAND, AS RESERVED IN THE GRANT DEED FROM DANIEL WALTER KLEINHANS, JR., RECORDED NOVEMBER 21, 1957 IN BOOK 2871, PAGE 422 OF OFFICIAL RECORDS.

ALSO EXCEPTING AND RESERVING AN UNDIVIDED ONE-HALF OF ANY AND ALL GROUNDWATER RIGHTS ASSOCIATED WITH THE PROPERTY THAT MAY BE FINALLY DETERMINED OR ADJUDICATED IN THE COORDINATION PROCEEDING KNOWN AS THE "ANTELOPE VALLEY GROUNDWATER CASES", BEING JUDICIAL COUNCIL COORDINATION PROCEEDING NO. 4408(3), AS RESERVED IN DEED RECORDED NOVEMBER 5, 2007 AS INSTRUMENT NO. 0207220993 OF OFFICIAL RECORDS.

**PARCEL 4: APN 261-196-03**

THE SOUTH HALF OF THE NORTHWEST QUARTER AND THE SOUTHWEST QUARTER OF THE NORTHEAST QUARTER OF SECTION 36, TOWNSHIP 9 NORTH, RANGE 15 WEST, MOUNT SAN BERNARDINO BASE AND MERIDIAN, AS PER THE OFFICIAL PLAT THEREOF.

EXCEPT 20% OF ALL OIL, MINERAL AND NATURAL GAS RIGHTS IN AND UNDER SAID LAND, AS RESERVED IN THE GRANT DEED FROM DANIEL WALTER KLEINHANS, JR., RECORDED NOVEMBER 21, 1957 IN BOOK 2871, PAGE 429 OF OFFICIAL RECORDS.

ALSO EXCEPTING AND RESERVING AN UNDIVIDED ONE-HALF OF ANY AND ALL GROUNDWATER RIGHTS ASSOCIATED WITH THE PROPERTY THAT MAY BE FINALLY DETERMINED OR ADJUDICATED IN THE COORDINATION PROCEEDING KNOWN AS THE "ANTELOPE VALLEY GROUNDWATER CASES", BEING JUDICIAL COUNCIL COORDINATION PROCEEDING NO. 4408(3), AS RESERVED IN DEED RECORDED NOVEMBER 5, 2007 AS INSTRUMENT NO. 0207220993 OF OFFICIAL RECORDS.

**PARCEL 5: APN 359-041-18**

LOTS 1 AND 2 OF THE SOUTHWEST QUARTER OF FRACTIONAL SECTION 31, TOWNSHIP 9 NORTH, RANGE 14 WEST, MOUNT SAN BERNARDINO BASE AND MERIDIAN, AS PER THE OFFICIAL PLAT THEREOF.

EXCEPT THE SOUTH 30 FEET THEREOF.

ALSO EXCEPTING AND RESERVING AN UNDIVIDED ONE-HALF OF ANY AND ALL GROUNDWATER RIGHTS ASSOCIATED WITH THE PROPERTY THAT MAY BE FINALLY DETERMINED OR ADJUDICATED IN THE COORDINATION PROCEEDING KNOWN AS THE "ANTELOPE VALLEY GROUNDWATER CASES", BEING JUDICIAL COUNCIL COORDINATION PROCEEDING NO. 4408(3), AS RESERVED IN DEED RECORDED NOVEMBER 5, 2007 AS INSTRUMENT NO. 0207220993 OF OFFICIAL RECORDS.

**PARCEL 6: APN 261-196-04**

THE SOUTHEAST QUARTER OF SECTION 36, TOWNSHIP 9 NORTH, RANGE 15 WEST, MOUNT SAN BERNARDINO BASE AND MERIDIAN, AS PER THE OFFICIAL PLAT THEREOF.

EXCEPT 3/4THS OF ALL OIL, GAS AND OTHER HYDROCARBON SUBSTANCES IN AND UNDER SAID LAND AS RESERVED IN THE DEED FROM DANIEL WALTER KLEINHANS, JR. AND AGNES G. KLEINHANS, HUSBAND AND WIFE, RECORDED JULY 15, 1965 IN BOOK 3857, PAGE 713 OF OFFICIAL RECORDS.

ALSO EXCEPTING AND RESERVING AN UNDIVIDED ONE-HALF OF ANY AND ALL GROUNDWATER RIGHTS ASSOCIATED WITH THE PROPERTY THAT MAY BE FINALLY DETERMINED OR ADJUDICATED IN THE COORDINATION PROCEEDING KNOWN AS THE "ANTELOPE VALLEY GROUNDWATER CASES", BEING JUDICIAL COUNCIL COORDINATION PROCEEDING NO. 4408(3), AS RESERVED IN DEED RECORDED NOVEMBER 5, 2007 AS INSTRUMENT NO. 0207220993 OF OFFICIAL RECORDS.

**PARCEL 7: APN 359-041-11**

THE NORTHEAST QUARTER OF SECTION 30, TOWNSHIP 9 NORTH, RANGE 14 WEST, MOUNT SAN BERNARDINO BASE AND MERIDIAN, ACCORDING TO THE OFFICIAL PLAT OF SAID LAND APPROVED BY THE SURVEYOR GENERAL FEBRUARY 19, 1856.

EXCEPTING AND RESERVING AN UNDIVIDED ONE-HALF OF ANY AND ALL GROUNDWATER RIGHTS ASSOCIATED WITH THE PROPERTY THAT MAY BE FINALLY DETERMINED OR ADJUDICATED IN THE COORDINATION PROCEEDING KNOWN AS THE "ANTELOPE VALLEY GROUNDWATER CASES", BEING JUDICIAL COUNCIL COORDINATION PROCEEDING NO. 4408(3), AS RESERVED IN DEED RECORDED NOVEMBER 5, 2007

AS INSTRUMENT NO. 0207220993 OF OFFICIAL RECORDS.

**PARCEL 8: APN 359-041-12**

ALL OF THE SOUTHEAST QUARTER OF SECTION 30, TOWNSHIP 9 NORTH, RANGE 14 WEST, MOUNT SAN BERNARDINO BASE AND MERIDIAN, ACCORDING TO THE OFFICIAL PLAT THEREOF.

EXCEPTING AND RESERVING AN UNDIVIDED ONE-HALF OF ANY AND ALL GROUNDWATER RIGHTS ASSOCIATED WITH THE PROPERTY THAT MAY BE FINALLY DETERMINED OR ADJUDICATED IN THE COORDINATION PROCEEDING KNOWN AS THE "ANTELOPE VALLEY GROUNDWATER CASES", BEING JUDICIAL COUNCIL COORDINATION PROCEEDING NO. 4408(3), AS RESERVED IN DEED RECORDED NOVEMBER 5, 2007 AS INSTRUMENT NO. 0207220993 OF OFFICIAL RECORDS.

**PARCEL 9: APN 359-041-17**

THE NORTHWEST QUARTER OF SECTION 31, TOWNSHIP 9 NORTH, RANGE 14 WEST, MOUNT SAN BERNARDINO BASE AND MERIDIAN, ACCORDING TO THE OFFICIAL PLAT THEREOF.

EXCEPTING AND RESERVING AN UNDIVIDED ONE-HALF OF ANY AND ALL GROUNDWATER RIGHTS ASSOCIATED WITH THE PROPERTY THAT MAY BE FINALLY DETERMINED OR ADJUDICATED IN THE COORDINATION PROCEEDING KNOWN AS THE "ANTELOPE VALLEY GROUNDWATER CASES", BEING JUDICIAL COUNCIL COORDINATION PROCEEDING NO. 4408(3), AS RESERVED IN DEED RECORDED NOVEMBER 5, 2007 AS INSTRUMENT NO. 0207220993 OF OFFICIAL RECORDS.

**PARCEL 10:**

A NON-EXCLUSIVE EASEMENT AND RIGHT OF WAY OVER THE NORTHERLY 18 FEET OF THE NORTH HALF OF SECTION 32, TOWNSHIP 9 NORTH RANGE 14 WEST, MOUNT SAN BERNARDINO BASE AND MERIDIAN, ACCORDING TO THE OFFICIAL PLAT THEREOF, FOR THE SOLE PURPOSE OF CONSTRUCTING, OPERATING, MAINTAINING, AND IF NECESSARY, REPLACING, AN UNDERGROUND WATER PIPELINE AS GRANTED IN DEED RECORDED November 24, 1976, IN BOOK 4992 PAGE 712, OF OFFICIAL RECORDS.

**PARCEL 11: APN 261-196-11**

THE SOUTHEAST QUARTER OF SECTION 25, TOWNSHIP 9 NORTH, RANGE 15 WEST, MOUNT SAN BERNARDINO BASE AND MERIDIAN, ACCORDING TO THE OFFICIAL PLAT THEREOF.

EXCEPTING AND RESERVING AN UNDIVIDED ONE-HALF OF ANY AND ALL GROUNDWATER RIGHTS ASSOCIATED WITH THE PROPERTY THAT MAY BE FINALLY DETERMINED OR ADJUDICATED IN THE COORDINATION PROCEEDING KNOWN AS THE "ANTELOPE VALLEY GROUNDWATER CASES", BEING JUDICIAL COUNCIL COORDINATION PROCEEDING NO. 4408(3), AS RESERVED IN DEED RECORDED NOVEMBER 5, 2007 AS INSTRUMENT NO. 0207220993 OF OFFICIAL RECORDS.



AVWS Additional 320 acres

THE LAND REFERRED TO HEREIN BELOW IS SITUATED IN THE UNINCORPORATED AREA, COUNTY OF KERN, STATE OF CALIFORNIA AND IS DESCRIBED AS FOLLOWS:

THE NORTH HALF OF SECTION 25, TOWNSHIP 9 NORTH, RANGE 15 WEST, MOUNT SAN BERNARDINO BASE AND MERIDIAN, ACCORDING TO THE OFFICIAL PLAT THEREOF.

EXCEPTING AND RESERVING AN UNDIVIDED ONE-HALF OF ANY AND ALL GROUNDWATER RIGHTS ASSOCIATED WITH THE PROPERTY THAT MAY BE FINALLY DETERMINED OR ADJUDICATED IN THE COORDINATION PROCEEDING KNOWN AS THE "ANTELOPE VALLEY GROUNDWATER CASES", BEING JUDICIAL COUNCIL COORDINATION PROCEEDING NO. 4408(3), AS RESERVED IN DEED RECORDED NOVEMBER 5, 2007 AS INSTRUMENT NO. 0207220991 OF OFFICIAL RECORDS.

APN: 261-196-09

THE LAND REFERRED TO HEREIN BELOW IS SITUATED IN THE COUNTY OF KERN, STATE OF CALIFORNIA, AND IS DESCRIBED AS FOLLOWS:

**Parcel 1:**

THE EAST HALF OF THE SOUTHWEST QUARTER OF SECTION 30, TOWNSHIP 9 NORTH, RANGE 14 WEST, SAN BERNARDINO MERIDIAN, IN THE COUNTY OF KERN, STATE OF CALIFORNIA, ACCORDING TO THE OFFICIAL PLAT THEREOF.

EXCEPT AN UNDIVIDED 1/2 OF ALL OIL, GAS, PETROLEUM AND OTHER MINERALS WITHIN OR UNDERLYING SAID LAND, OR WHICH MAY BE PRODUCED AND SAVED THEREFROM AS RESERVED BY RUPERT R. SINGLETON, ET UX, IN DEED RECORDED MAY 27, 1957 IN BOOK 2793 PAGES 89, AND 90 OF OFFICIAL RECORDS.

BY DEED DATED MARCH 12, 1970 AND RECORDED MARCH 31, 1970 IN BOOK 4383 PAGE 65, OF OFFICIAL RECORDS, ETHEL J. SINGLETON, A WIDOW, QUITCLAIMED UNTO TONY A. CAFARO AND ANABELLA LEE CAFARO, HUSBAND AND WIFE AS JOINT TENANTS, ALL SURFACE RIGHTS OF ENTRY TO A DEPTH OF 500 FEET BELOW THE PRESENT SURFACE AS TO AN UNDIVIDED 1/2 INTEREST IN AND TO ALL OIL, GAS, PETROLEUM AND OTHER MINERALS WITHIN OR UNDERLYING SAID LAND, OR WHICH MAY BE PRODUCED AND SAVED THEREFROM AS RESERVED BY RUPERT R. SINGLETON, ET UX, IN DEEDS RECORDED MAY 27, 1957 IN BOOK 2793 PAGES 89 AND 90 OF OFFICIAL RECORDS.

**PARCEL 2:**

THE WEST HALF OF THE EAST HALF OF THE NORTHWEST QUARTER OF SECTION 30, TOWNSHIP 9 NORTH, RANGE 14 WEST, SAN BERNARDINO MERIDIAN, IN THE COUNTY OF KERN, STATE OF CALIFORNIA, ACCORDING TO THE OFFICIAL PLAT THEREOF.

SAID LAND IS SHOWN AS PARCELS 1 THROUGH 4 INCLUSIVE, OF PARCEL MAP NO. 5126, AS PER MAP RECORDED IN BOOK 25 PAGE 159 OF PARCEL MAPS, IN THE OFFICE THE COUNTY RECORDER OF SAID COUNTY.

APN: 359-041-20,21,22,23,13

**PARCEL 1:**

THE EAST HALF OF THE LOTS 1 AND 2 IN THE NORTHWEST QUARTER OF SECTION 6, TOWNSHIP 8 NORTH, RANGE 14 WEST, SAN BERNARDINO BASE AND MERIDIAN, IN THE COUNTY OF LOS ANGELES, STATE OF CALIFORNIA, ACCORDING TO THE OFFICIAL PLAT OF SAID LAND.

RESERVING AN UNDIVIDED ONE-HALF OF ANY AND ALL GROUNDWATER RIGHTS ASSOCIATED WITH THE PROPERTY THAT MAY BE FINALLY DETERMINED OR ADJUDICATED IN THE COORDINATION PROCEEDING KNOWN AS THE "ANTELOPE VALLEY GROUNDWATER CASES", BEING JUDICIAL COUNCIL COORDINATION PROCEEDING NO. 4408(3), AS RESERVED BY CRAIG A. VAN DAM AND MARTA L. VAN DAM, HUSBAND AND WIFE, AS JOINT TENANTS, IN DEED RECORDED NOVEMBER 5, 2007 AS INSTRUMENT NO. 07-2481684, OF OFFICIAL RECORDS.

**PARCEL 2:**

THE NORTHWEST QUARTER OF THE NORTHWEST QUARTER OF SECTION 30, TOWNSHIP 9 NORTH, RANGE 14 WEST, MOUNT SAN BERNARDINO BASE AND MERIDIAN, IN THE COUNTY OF KERN, STATE OF CALIFORNIA ACCORDING TO THE OFFICIAL PLAT THEREOF.

RESERVING AN UNDIVIDED ONE-HALF INTEREST OF ANY AND ALL GROUNDWATER RIGHTS ASSOCIATED WITH THE PROPERTY THAT MAY FULLY DETERMINED OR ADJUDICATED IN THE COORDINATION PROCEEDING KNOWN AS THE "ANTELOPE VALLEY GROUNDWATER CASES", BEING JUDICIAL COUNCIL COORDINATION PROCEEDING NO. 4408(3), AS RESERVED BY CRAIG A. VAN DAM AND MARTA L. VAN DAM, HUSBAND AND WIFE, AS JOINT TENANTS, IN DEED RECORDED NOVEMBER 5, 2007 AS INSTRUMENT NO. 07-220990, OF OFFICIAL RECORDS.

**END OF DESCRIPTION**

EXHIBIT A  
DESCRIPTION OF LAND

Grimmway

**LEGAL DESCRIPTION**

THE LAND REFERRED TO HEREIN BELOW IS SITUATED IN THE COUNTY OF KERN, STATE OF CALIFORNIA AND IS DESCRIBED AS FOLLOWS:

**PARCEL 1:** APNS: 359-011-01 THROUGH 24

PARCELS 1 THROUGH 24, INCLUSIVE, OF PARCEL MAP NO. 7981, IN THE UNINCORPORATED AREA OF THE COUNTY OF KERN, STATE OF CALIFORNIA, AS PER MAP FILED NOVEMBER 25, 1987 IN BOOK 35 PAGE 43 OF PARCEL MAPS, IN THE OFFICE OF THE COUNTY RECORDER OF SAID COUNTY.

EXCEPT THE WEST 30 FEET OF LOTS 1 (EXCEPT THE NORTH 1100 FEET THEREOF), 9, 17 AND 21 AS CONVEYED TO THE ANTELOPE VALLEY-EAST KERN WATER AGENCY IN THE DEEDS RECORDED OCTOBER 3, 1989 IN BOOK 6298 PAGES 1794, 1797 AND 1800 OF OFFICIAL RECORDS.

ALSO EXCEPT FROM SAID LAND WITHIN THE SOUTH HALF OF THE NORTHEAST QUARTER AND THE NORTHEAST QUARTER OF THE NORTHEAST QUARTER OF SECTION 22, TOWNSHIP 9 NORTH, RANGE 14 WEST, SAN BERNARDINO BASE AND MERIDIAN, 50% OF ALL OIL, GAS AND MINERAL RIGHTS, AS RESERVED BY OPAL ERNE, AN UNMARRIED WOMAN, IN DEED RECORDED MARCH 25, 1955 IN BOOK 2395 PAGE 514, OF OFFICIAL RECORDS.

AND ALSO EXCEPT FROM SAID LAND WITHIN THE NORTHWEST QUARTER OF THE NORTHEAST QUARTER OF SECTION 22, TOWNSHIP 9 NORTH, RANGE 14 WEST, SAN BERNARDINO BASE AND MERIDIAN, ALL OF THE OIL, GAS, GOLD, SILVER AND OTHER PRECIOUS METALS, MINERALS AND MINERAL SUBSTANCES IN AND UNDER AND THAT MAY BE PRODUCED FROM SAID LAND TOGETHER WITH THE RIGHT OF INGRESS AND EGRESS AT ALL TIMES FOR THE PURPOSE OF MINING, DRILLING AND EXPLORING SAID LANDS FOR ANY AND ALL OIL, GAS, MINERALS AND MINERAL SUBSTANCES AND REMOVING THE SAME THEREFROM, AS GRANTED TO INDUSTRIAL LESSORS, INC., A NEVADA CORPORATION, IN DEED RECORDED JULY 18, 1956 IN BOOK 2638 PAGE 89, OF OFFICIAL RECORDS.

**PARCEL 2:** APN: 359-020-50

PARCEL 2 OF PARCEL MAP WAIVER 17-98, AS SHOWN ON CERTIFICATE OF COMPLIANCE, RECORDED MARCH 3, 1999, AS INSTRUMENT NO. 0199030750, BEING THE SOUTHEAST QUARTER OF SECTION 21, TOWNSHIP 9 NORTH, RANGE 14 WEST, SAN BERNARDINO BASE AND MERIDIAN, IN THE UNINCORPORATED AREA, COUNTY OF KERN, STATE OF CALIFORNIA, AS SHOWN ON THE OFFICIAL PLAT THEREOF.

**PARCEL 3:** APNS: 359-174-01 THROUGH 12

PARCELS 1 THROUGH 12, INCLUSIVE, OF PARCEL MAP 8156, IN THE UNINCORPORATED AREA OF THE COUNTY OF KERN, STATE OF CALIFORNIA, AS PER MAP FILED DECEMBER 17, 1987 IN BOOK 35, PAGE 53 OF PARCEL MAPS, IN THE OFFICE OF THE COUNTY RECORDER OF SAID COUNTY.

EXCEPTING THEREFROM THE WEST 30 FEET OF PARCELS 3 AND 9, AS CONVEYED TO ANTELOPE VALLEY-EAST KERN WATER AGENCY BY DEED RECORDED October 3, 1989 IN BOOK 6298, PAGE 1792 OF OFFICIAL RECORDS.

ALSO EXCEPT ALL OIL, GAS, MINERALS AND OTHER HYDROCARBON SUBSTANCES WITHIN OR UNDERLYING SAID LAND, OR THAT MAY BE PRODUCED AND SAVED THEREFROM; PROVIDING, HOWEVER, THAT GRANTORS, THEIR SUCCESSORS AND ASSIGNS, SHALL NOT CONDUCT DRILLING OR OTHER OPERATIONS UPON THE SURFACE OF SAID LAND, BUT NOTHING HEREIN SHALL BE DEEMED TO PREVENT THE EXTRACTING OR CAPTURING OF SAID MINERALS BY DRILLING ON ADJACENT OR NEIGHBORING LAND AND/OR FROM CONDUCTING OPERATIONS UNDER SAID LAND AT A DEPTH OF 500 FEET BELOW THE SURFACE OF SAID LAND SO AS NOT TO DISTURB THE SURFACE THEREOF OR ANY IMPROVEMENTS THEREON, AS RESERVED BY ARMANDO IARUSSI AND EMMA VERA IARUSSI, HUSBAND AND WIFE, IN DEED RECORDED NOVEMBER 30, 1990 IN BOOK 6459, PAGE 1112 OF OFFICIAL RECORDS.

ALSO RESERVING TO EMMA VERA IARUSSI, TRUSTEE OF THE ARMANDO IARUSSI AND EMMA VERA IARUSSI FAMILY TRUST DATED MAY 8, 1991 ALL OIL, GAS, MINERALS AND OTHER HYDROCARBON SUBSTANCES WITHIN OR UNDERLYING SAID LAND, OR THAT MAY BE PRODUCED AND SAVED THEREFROM; PROVIDING,

EXHIBIT "A" (continued)

HOWEVER, THAT EMMA VERA IARUSSI, TRUSTEE OF THE ARMANDO IARUSSI AND EMMA VERA IARUSSI TRUST HER SUCCESSORS AND ASSIGNS, SHALL NOT CONDUCT DRILLING OR OTHER OPERATIONS UPON THE SURFACE OF SAID LAND, BUT NOTHING HEREIN SHALL BE DEEMED TO PREVENT THE EXTRACTING OR CAPTURING OF SAID MINERALS BY DRILLING ON ADJACENT OR NEIGHBORING LAND AND/OR FROM CONDUCTING OPERATIONS UNDER SAID LAND AT A DEPTH OF 500 FEET BELOW THE SURFACE OF SAID LAND SO AS NOT TO DISTURB THE SURFACE THEREOF OR ANY IMPROVEMENTS THEREON, AS RESERVED IN DEED RECORDED MARCH 11, 1998, AS INSTRUMENT NO. 0198030172, OF OFFICIAL RECORDS.

**PARCEL 4:** APN: 359-240-04 (PORTION)

ALL THAT PORTION OF THE NORTHWEST QUARTER OF SECTION 22, TOWNSHIP 9 NORTH, RANGE 14 WEST, SAN BERNARDINO BASE AND MERIDIAN, IN THE UNINCORPORATED AREA OF THE COUNTY OF KERN, STATE OF CALIFORNIA, ACCORDING TO THE RECORD OF SURVEY MAP AS RECORDED MARCH 22, 1961 IN BOOK 8 PAGE 52 OF RECORD OF SURVEYS.

BEGINNING AT THE SOUTHWEST CORNER OF THE NORTHWEST QUARTER OF SAID SECTION; THENCE NORTH 1 ° 06' 00" WEST, ALONG THE WEST LINE OF SAID SECTION, 2646.88 FEET TO THE NORTHWEST CORNER OF SAID SECTION; THENCE NORTH 89 ° 37' 29" EAST ALONG THE NORTH LINE OF SAID SECTION, 75.96 FEET; THENCE SOUTH 0 ° 22' 31" EAST, 55.00 FEET TO A NON-TANGENT CURVE CONCAVE SOUTHEASTERLY HAVING A RADIUS OF 20.00 FEET, A RADIAL LINE TO THE CENTER OF SAID CURVE BEARS SOUTH 0 ° 22' 31" EAST, THENCE WESTERLY ALONG SAID CURVE THROUGH A CENTRAL ANGLE OF 90 ° 43' 35", AN ARC DISTANCE OF 31.67 FEET; THENCE SOUTH 1 ° 06' 06" EAST, PARALLEL WITH AND 55.00 FEET EAST AS MEASURED AT RIGHT ANGLES TO THE WEST LINE OF SAID SECTION, 2571.65 FEET TO THE SOUTH LINE OF NORTHWEST QUARTER OF SAID SECTION; THENCE SOUTH 89 ° 39' 05" WEST ALONG SAID SOUTH LINE 55.00 FEET TO THE TRUE POINT OF BEGINNING.

**PARCEL 5:** APN: 359-240-04 (PORTION)

ALL OF THE SOUTHWEST QUARTER OF SECTION 22, TOWNSHIP 9 NORTH, RANGE 14 WEST, SAN BERNARDINO BASE AND MERIDIAN, KERN COUNTY, STATE OF CALIFORNIA, ACCORDING TO THE OFFICIAL PLAT THEREOF, BEING MORE PARTICULARLY DESCRIBED AS FOLLOWS:

BEGINNING AT THE NORTHWEST CORNER OF THE SOUTHWEST QUARTER OF SAID SECTION; THENCE 89 ° 39' 05" EAST, ALONG THE NORTHWEST LINE OF SAID SOUTHWEST QUARTER, 2639.00 FEET TO THE CENTER OF SAID SECTION; THENCE SOUTH 1 ° 04' 21" EAST, ALONG THE EAST LINE OF SAID SOUTHWEST QUARTER, 2648.38 FEET TO THE SOUTH QUARTER CORNER OF SAID SECTION; THENCE SOUTH 89 ° 41' 29" WEST, ALONG THE SOUTH LINE OF SAID SECTION, 2637.89 FEET TO THE SOUTHWEST CORNER OF SAID SECTION; THENCE NORTH 1 ° 05' 50" WEST, ALONG THE WEST LINE OF SAID SECTION, 2646.55 FEET TO THE POINT OF BEGINNING.

APN: 359-011-01 thru -24, 359-020-50, 359-174-01 thru -12, 359-240-04

THE LAND REFERRED TO HEREIN BELOW IS SITUATED IN THE UNINCORPORATED AREA, COUNTY OF KERN; STATE OF CALIFORNIA, AND IS DESCRIBED AS FOLLOWS:

The Southwest quarter of Section 25, Township 9 North, Range 15 West, San Bernardino Meridian, in the unincorporated area of the County of Kern, State of California, according to the Official Plat thereof.

APN: 261-196-10

Real property in the unincorporated area of the County of Kern, State of California, described as follows:

PARCELS 1, 3 AND 4 OF PARCEL MAP NO. 9211, IN THE UNINCORPORATED AREA OF KERN, IN THE COUNTY OF KERN, STATE OF CALIFORNIA, AS SHOWN ON MAP RECORDED IN BOOK 41 OF PARCEL MAPS, PAGE 10, IN THE OFFICE OF THE COUNTY RECORDER OF SAID COUNTY.

APN: 359-331-24-00-8, 359-331-26-00-4 and 359-331-27-00-7

Real property in the unincorporated area of the County of Kern, State of California, described as follows:

PARCEL 2 OF PARCEL MAP NO. 9211, IN THE UNINCORPORATED AREA, COUNTY OF KERN, STATE OF CALIFORNIA, AS PER MAP RECORDED IN BOOK 41, PAGE 9 OF PARCEL MAPS, IN THE OFFICE OF THE COUNTY RECORDER OF SAID COUNTY.

APN: 359-331-25

Real property in the unincorporated area of the County of Kern, State of California, described as follows:

PARCEL 1:

THE EAST HALF OF THE SOUTHEAST QUARTER OF SECTION 27, TOWNSHIP 9 NORTH, RANGE 14 WEST, SAN BERNARDINO MERIDIAN, IN THE UNINCORPORATED AREA OF THE COUNTY OF KERN, STATE OF CALIFORNIA, ACCORDING TO THE OFFICIAL PLAT THEREOF.

EXCEPT THE NORTHERLY 20.00 FEET OF THE SOUTHERLY 50.00 FEET THEREOF.

ALSO EXCEPT THAT PORTION INCLUDED IN PARCEL MAP NO. 2088.

APN: 359-175-01

PARCEL 2:

PARCELS 1, 2 AND 3 IN THE UNINCORPORATED AREA, COUNTY OF KERN, STATE OF CALIFORNIA, AS SHOWN ON PARCEL MAP NO. 2088, FILED APRIL 24, 1975 IN BOOK 13 PAGE 110 OF PARCEL MAPS, IN THE OFFICE OF THE COUNTY RECORDER OF KERN COUNTY.

EXCEPT THE NORTHERLY 20.00 FEET OF THE SOUTHERLY 50.00 FEET THEREOF.

APN: 359-175-02, 03-04

PARCEL 3:

THE EAST HALF OF THE SOUTHEAST QUARTER OF SECTION 34, TOWNSHIP 9 NORTH, RANGE 14 WEST, SAN BERNARDINO MERIDIAN, IN THE UNINCORPORATED AREA OF THE COUNTY OF KERN, STATE OF CALIFORNIA, ACCORDING TO THE OFFICIAL PLAT THEREOF.

APN: 359-321-01

Real property in the unincorporated area of the County of Kern, State of California, described as follows:

PARCEL 4 OF PARCEL MAP 8370, IN THE UNINCORPORATED AREA OF THE COUNTY OF KERN, STATE OF CALIFORNIA, AS PER PARCEL MAP RECORDED NOVEMBER 30, 1987, IN BOOK 35, PAGE(S) 49 OF PARCEL MAPS, IN THE OFFICE OF THE COUNTY RECORDER OF SAID COUNTY.

EXCEPTING THEREFROM 50% OF ALL COAL, OIL, PETROLEUM, GAS, MINERALS AND OTHER HYDROCARBON SUBSTANCES LYING BELOW A DEPTH OF 500 FEET FROM THE SURFACE OF SAID LAND, BUT WITHOUT ANY RIGHTS TO THE GRANTORS, THEIR HEIRS, EXECUTORS OR ASSIGNS, TO ENTER UPON THE SURFACE OF SAID LAND, OR THE SUB-SURFACE THEREOF TO A DEPTH OF 500 FEET, FOR THE PURPOSE OF TAKING THEREFROM ANY SUCH SUBSTANCES MENTIONED HEREIN, AS RESERVED BY LESLIE C. WEAVER AND HAZEL L. WEAVER, HUSBAND AND WIFE, IN DEED DATED JANUARY 27, 1989 AND RECORDED FEBRUARY 13, 1989, IN BOOK 6208, PAGE(S) 1290 AS INSTRUMENT NO. 015620 OF OFFICIAL RECORDS.

APN: 359-324-21

Real property in the unincorporated area of the County of Kern, State of California, described as follows:

THE WEST HALF OF THE SOUTHEAST QUARTER OF SECTION 34, TOWNSHIP 9 NORTH OF RANGE 14 WEST OF THE S. B. B. & M., IN THE UNINCORPORATED AREA, OF THE COUNTY OF KERN, STATE OF CALIFORNIA.

APN: 359-321-02

Real property in the unincorporated area of the County of Kern, State of California, described as follows:  
PARCEL 3 OF PARCEL MAP 8370 IN THE UNINCORPORATED AREA OF THE COUNTY OF KERN, STATE OF CALIFORNIA, AS PER MAP RECORDED NOVEMBER 30, 1987, IN BOOK 35, PAGE 49 OF PARCEL MAPS, IN THE OFFICE OF THE COUNTY RECORDER OF SAID COUNTY.

APN: 359-324-20

Real property in the unincorporated area of the County of Kern, State of California, described as follows:

PARCEL 1 OF PARCEL MAP 8370 IN THE UNINCORPORATED AREA OF THE COUNTY OF KERN, STATE OF CALIFORNIA, AS PER MAP RECORDED NOVEMBER 30, 1987, IN BOOK 35, PAGE 49 OF PARCEL MAPS, IN THE OFFICE OF THE COUNTY RECORDER OF SAID COUNTY.

APN: 359-324-18

Real property in the unincorporated area of the County of Kern, State of California, described as follows:

PARCEL NO. 4 OF PARCEL MAP NO. 8294, IN THE COUNTY OF KERN, STATE OF CALIFORNIA, AS FILED OCTOBER 22, 1987 IN BOOK 35, PAGE 17 OF PARCEL MAPS, RECORDS OF SAID COUNTY.

APN: 359-331-19-00-4

Real property in the unincorporated area of the County of Kern, State of California, described as follows:

PARCEL NO. 2 OF PARCEL MAP NO. 8294, IN THE COUNTY OF KERN, STATE OF CALIFORNIA, FILED OCTOBER 22, 1987 IN BOOK 35, PAGE 17 OF PARCEL MAPS, IN THE OFFICE OF THE COUNTY RECORDER OF SAID COUNTY.

APN: 359-331-17-00-8

PARCELS 1 AND 2 OF PARCEL MAP 1028, IN THE UNINCORPORATED AREA, COUNTY OF KERN, STATE OF CALIFORNIA, AS PER MAP RECORDED AUGUST 14, 1973 IN BOOK 6, PAGE 140 OF PARCEL MAPS, IN THE OFFICE OF THE COUNTY RECORDER OF SAID COUNTY.

APN: 359-041-07-00-5 and 359-041-08-00-8

Real property in the unincorporated area of the County of Kern, State of California, described as follows:

THE SOUTHEAST QUARTER OF THE SOUTHEAST QUARTER OF FRACTIONAL SECTION 31, TOWNSHIP 9 NORTH, RANGE 14 WEST, SAN BERNARDINO BASE AND MERIDIAN, IN THE UNINCORPORATED AREA OF THE COUNTY OF KERN, STATE OF CALIFORNIA. EXCEPTING THEREFROM 50% OF OIL AND MINERAL INTEREST BELOW A DEPTH OF 500 FEET FROM THE SURFACE OF SAID LAND, WITHOUT THE RIGHT OF SURFACE ENTRY, AS RESERVED BY RECA CORPORATION, IN DEED RECORDED DECEMBER 5, 1986 IN BOOK 5944, PAGE 2046 OF OFFICIAL RECORDS.

ALSO DESCRIBED AS PARCEL 1 OF PARCEL MAP WAIVER NO. 769 RECORDED NOVEMBER 4, 1986 IN BOOK 5933, PAGE 2332 OF OFFICIAL RECORDS IN THE OFFICE OF THE RECORDER OF THE COUNTY OF KERN, STATE OF CALIFORNIA.

APN: 359-041-30-00-1

Real property in the unincorporated area, County of Kern, State of California, described as follows:

PARCEL 1:

THE NORTHEAST QUARTER OF THE SOUTHEAST QUARTER OF FRACTIONAL SECTION 31, TOWNSHIP 9 NORTH, RANGE 14 WEST, SAN BERNARDINO MERIDIAN, IN THE UNINCORPORATED AREA OF THE COUNTY OF KERN, STATE OF CALIFORNIA, ACCORDING TO THE OFFICIAL PLAT THEREOF, AND BY CERTIFICATE OF COMPLIANCE RECORDED NOVEMBER 4, 1986 IN BOOK 5933, PAGE 2332 OF OFFICIAL RECORDS.

EXCEPT THEREFROM 50% OF ALL OIL AND MINERAL INTEREST IN SUBJECT PROPERTY, BELOW A DEPTH OF 500 FEET FROM THE SURFACE OF SAID LAND, AND WITHOUT THE RIGHT OF SURFACE ENTRY AS RESERVED BY RECA CORPORATION IN DEED RECORDED DECEMBER 5, 1986 IN BOOK 5944, PAGE 2051 OF OFFICIAL RECORDS.

PARCEL 2:

THE SOUTHWEST QUARTER OF THE SOUTHEAST QUARTER OF FRACTIONAL SECTION 31, TOWNSHIP 9 NORTH, RANGE 14 WEST, S.B.M., IN THE UNINCORPORATED AREA, COUNTY OF KERN, STATE OF CALIFORNIA, ACCORDING TO THE OFFICIAL PLAT THEREOF, AND BY CERTIFICATE OF COMPLIANCE, RECORDED NOVEMBER 4, 1986 IN BOOK 5933, PAGE 2332, OF OFFICIAL RECORDS.



EXCEPTING THEREFROM 50% OF ALL OIL AND MINERAL INTEREST IN SUBJECT PROPERTY, BELOW A DEPTH OF 500 FEET FROM THE SURFACE OF SAID LAND AND WITHOUT THE RIGHT OF SURFACE ENTRY AS RESERVED BY RECA CORPORATION IN DEED RECORDED DECEMBER 5, 1986 IN BOOK 5944, PAGE 2048, OFFICIAL RECORDS.

PARCEL 3:

THE NORTHWEST QUARTER OF THE SOUTHEAST QUARTER OF FRACTIONAL SECTION 31, TOWNSHIP 9 NORTH, RANGE 14 WEST, S.B.B.M., IN THE UNINCORPORATED AREA OF THE COUNTY OF KERN, STATE OF CALIFORNIA, AS PER MAP OF THE OFFICIAL PLAT THEREOF, AND BY CERTIFICATE OF COMPLIANCE RECORDED NOVEMBER 4, 1986 IN BOOK 5933, PAGE 2332 OF OFFICIAL RECORDS.

EXCEPTING THEREFROM 50% OF ALL OIL AND MINERAL INTEREST IN SUBJECT PROPERTY, BELOW A DEPTH OF 500 FEET FROM THE SURFACE OF SAID LAND, AND WITHOUT THE RIGHT OF SURFACE ENTRY AS RESERVED BY RECA CORPORATION IN DEED RECORDED DECEMBER 5, 1986 IN BOOK 5944, PAGE 2044 OF OFFICIAL RECORDS.

Kern County APN's and Affects  
359-041-29-00-9 (Parcel 1)  
359-041-31-00-4 (Parcel 2)  
359-041-32-00-7 (Parcel 3)

Real property in the unincorporated area of the County of Kern, State of California, described as follows:

PARCEL 1

THE SOUTHEAST ¼ OF THE SOUTHWEST ¼ OF THE SOUTHWEST ¼ OF FRACTIONAL SECTION 30, IN TOWNSHIP 9 NORTH, RANGE 14 WEST, SAN BERNARDINO BASE AND MERIDIAN, U/A, CO./KERN, ST/CA.

APN: 359-041-26-00-0

PARCEL 2

THE NORTHEAST QUARTER OF THE SOUTHWEST QUARTER OF THE SOUTHWEST QUARTER OF FRACTIONS SECTION 30, IN TOWNSHIP 9 NORTH, RANGE 14 WEST, S.B.B.M., U/A, CO/KERN, ST/CA.

APN: 359-041-25-00-7

PARCEL 3:

THE NORTHWEST QUARTER OF THE SOUTHWEST QUARTER OF SECTION 30, TOWNSHIP 9 NORTH, RANGE 14 WEST, SAN BERNARDINO MERIDIAN, IN THE UNINCORPORATED AREA OF THE COUNTY OF KERN, STATE OF CALIFORNIA, ACCORDING TO THE OFFICIAL PLAT THEREOF.

APN: 359-041-15-00-8

PARCEL 4:

THE SOUTHWEST ¼ OF THE SOUTHWEST ¼ OF THE SOUTHWEST ¼ OF FRACTIONAL SECTION 30, TOWNSHIP 9 NORTH, RANGE 14 WEST, SBB&M IN THE UNINCORPORATED AREA OF THE COUNTY OF KERN, STATE OF CALIFORNIA ACCORDING TO THE OFFICIAL PLAT THEREOF.

APN: 359-041-27-00-3

PARCEL 5:

THE NORTHWEST ¼ OF THE SOUTHWEST ¼ OF THE SOUTHWEST ¼ OF FRACTIONAL SECTION 30, IN THE TOWNSHIP 9 NORTH, RANGE 14 WEST, SAN BERNARDINO BASE AND MERIDIAN, U/A, CO/KEN, ST/CA.

APN: 359-041-24-00-4

Real property in the unincorporated area of the County of Kern, State of California, described as follows:

THE NORTH HALF OF SECTION 27, TOWNSHIP 9 NORTH, RANGE 15 WEST, SAN BERNARDINO MERIDIAN, IN THE UNINCORPORATED AREA OF THE COUNTY OF KERN, STATE OF CALIFORNIA, ACCORDING TO THE OFFICIAL PLAT OF SAID LAND APPROVED BY THE SURVEYOR GENERAL ON FEBRUARY 19, 1856.

APN: 261-193-01-00-3

Real property in the unincorporated area of the County of Kern, State of California, described as follows:

PARCEL 4 OF PARCEL MAP NO. 1050 IN THE UNINCORPORATED AREA OF THE COUNTY OF KERN STATE OF CALIFORNIA AS PER MAP RECORDED AUGUST 14, 1973 IN BOOK 6 PAGE 141 OF PARCEL MAPS. ALSO DESCRIBED AS A PORTION OF THE SOUTHWEST ¼ OF THE NORTHWEST ¼ OF SECTION 30, TOWNSHIP 9 NORTH, RANGE 14 WEST SAN BERNARDINO MERIDIAN.

APN: 359-041-05-00-9

Real property in the unincorporated area of the County of Los Angeles, State of California, described as follows:

PARCEL 1:

THE NORTHEAST ONE-QUARTER AND THE SOUTH ONE-HALF OF SECTION 5, TOWNSHIP 8 NORTH, 14 WEST, SAN BERNARDINO MERIDIAN IN THE COUNTY OF LOS ANGELES, STATE OF CALIFORNIA, ACCORDING TO THE OFFICIAL PLAT OF SAID LAND APPROVED BY THE SURVEYOR GENERAL, FEBRUARY 19, 1856.

EXCEPT THEREFROM ANY PORTION OF SAID LAND WITHIN ANY PUBLIC ROADS EXISTING ON OR BEFORE JANUARY 19, 1923.

EXCEPT THEREFROM ALL RIGHTS, TITLE AND INTEREST IN AND TO FIFTY (50%) PERCENT OF ALL OIL, MINERAL, GAS AND OTHER HYDROCARBON SUBSTANCES BELOW A DEPTH OF 500 FEET UNDER THE PROPERTY, WITHOUT THE RIGHT OF SURFACE ENTRY, AS RESERVED IN A DEED RECORDED DECEMBER 27, 1988 AS INSTRUMENT NO. 88-2059369 OFFICIAL RECORDS.

PARCEL 2:

THE NORTHWEST ONE-QUARTER OF SECTION 5, TOWNSHIP 8 NORTH, RANGE 14 WEST, SAN BERNARDINO MERIDIAN, IN THE COUNTY OF LOS ANGELES, STATE OF CALIFORNIA, ACCORDING TO THE OFFICIAL PLAT OF SAID LAND APPROVED BY THE SURVEYOR GENERAL, FEBRUARY 19, 1856.

EXCEPT THEREFROM ANY PORTION OF SAID LAND WITHIN ANY PUBLIC ROADS EXISTING ON OR BEFORE JANUARY 19, 1923.

EXCEPT THEREFROM ALL RIGHTS, TITLE AND INTEREST IN AND TO FIFTY (50%) PERCENT OF ALL OIL, MINERAL, GAS AND OTHER HYDROCARBON SUBSTANCES BELOW A DEPTH OF 500 FEET UNDER THE PROPERTY, WITHOUT THE RIGHT OF SURFACE ENTRY, AS RESERVED IN A DEED RECORDED DECEMBER 27, 1988 AS INSTRUMENT NO. 88-2059371 OFFICIAL RECORDS.

Los Angeles County APN's and Affects

3258-001-030 (Parcel 2)

3258-001-031 (Parcel 1)

Real property in the unincorporated area of the County of Los Angeles, State of California, described as follows:

THE EAST 40.45 ACRES OF LOT 2 IN THE NORTHEAST QUARTER OF SECTION 6, TOWNSHIP 8 NORTH, RANGE 14 WEST, SAN BERNARDINO MERIDIAN, IN THE COUNTY OF LOS ANGELES, STATE OF CALIFORNIA.

(APN: 3258-001-024)

Real property in the unincorporated area of the County of Los Angeles, State of California, described as follows:

LOT 1 IN THE NORTHEAST ONE-QUARTER OF SECTION 6, TOWNSHIP 8 NORTH, RANGE 14 WEST, SAN BERNARDINO MERIDIAN, IN THE COUNTY OF LOS ANGELES, STATE OF CALIFORNIA, ACCORDING TO THE OFFICIAL PLAT OF SAID LAND.

(APN: 3258-001-040)

Real property in the unincorporated area of the County of Los Angeles, State of California, described as follows:

PARCEL 1: (APN: 3258-001-001)

THE NORTHWEST QUARTER OF THE SOUTHWEST QUARTER AND THE NORTHERLY 32.98 ACRES OF THE SOUTHWEST QUARTER OF THE SOUTHWEST QUARTER OF SECTION 6, TOWNSHIP 8 NORTH, RANGE 14 WEST, SAN BERNARDINO MERIDIAN, IN THE COUNTY OF LOS ANGELES, STATE OF CALIFORNIA.

PARCEL 2: (APN: 3258-001-038)

THE WEST 80 ACRES OF THE SOUTHEAST QUARTER OF SECTION 6, TOWNSHIP 8 NORTH, RANGE 14 WEST, SAN BERNARDINO MERIDIAN, IN THE COUNTY OF LOS ANGELES, STATE OF CALIFORNIA, ACCORDING TO THE OFFICIAL PLAT OF SAID LAND APPROVED BY THE SURVEYOR GENERAL FEBRUARY 19, 1856.

PARCEL 3: (APN: 3261-001-003)

THE EAST ONE-HALF OF THE NORTHWEST QUARTER OF SECTION 4, TOWNSHIP 8 NORTH, RANGE 14 WEST, SAN BERNARDINO MERIDIAN, IN THE COUNTY OF LOS ANGELES, STATE OF CALIFORNIA, ACCORDING TO THE OFFICIAL PLAT OF SAID LAND APPROVED BY THE SURVEYOR GENERAL ON FEBRUARY 19, 1856.

Real property in the unincorporated area of the County of Los Angeles, State of California, described as follows:

THE WEST HALF OF THE NORTHWEST QUARTER OF SECTION 4, TOWNSHIP 8 NORTH, RANGE 14 WEST, SAN BERNARDINO MERIDIAN, IN THE COUNTY OF LOS ANGELES, STATE OF CALIFORNIA, ACCORDING TO THE OFFICIAL PLAT THEREOF.

EXCEPT THE SOUTH  $\frac{1}{2}$  OF THE SOUTHWEST  $\frac{1}{4}$  OF THE SOUTHWEST  $\frac{1}{4}$  OF THE NORTHWEST  $\frac{1}{4}$  OF SAID SECTION 4.

APN: 3261-001-002

Real property in the unincorporated area of the County of Los Angeles, State of California, described as follows:

LOTS 1 AND 2 OF THE NORTHEAST QUARTER OF SECTION 4, TOWNSHIP 8 NORTH, RANGE 14 WEST, SAN BERNARDINO MERIDIAN, IN THE COUNTY OF LOS ANGELES, STATE OF CALIFORNIA, ACCORDING TO THE OFFICIAL PLAT OF SAID LAND.

APN: 3261-001-004

Real property in the unincorporated area of the County of Los Angeles, State of California, described as follows:

THE EAST 2.025 ACRES OF THE SOUTH 4.05 ACRES OF LOT 2 OF THE SOUTHWEST OF SECTION 6 TOWNSHIP 8 WEST, RANGE 14 WEST, SAN BERNARDINO MERIDIAN, IN THE COUNTY OF LOS ANGELES, STATE OF CALIFORNIA.

EXCEPTING THEREFROM THE SOUTHERLY 50 FEET OF THE SOUTHWEST QUARTER OF SECTION 6, TOWNSHIP 8 NORTH, RANGE 14 WEST, SAN BERNARDINO MERIDIAN, AS SET ASIDE BY THE COUNTY OF LOS ANGELES FOR PUBLIC ROAD AND HIGHWAY PURPOSES IN RESOLUTION RECORDED AUGUST 4, 1971 AS INSTRUMENT 3742, OF OFFICIAL RECORDS.

3258-001-025 (Hemmerling Extra Parcel)

**EXHIBIT B-2**

*Single-Line Diagram of the CAISO-Controlled Grid Interconnection*

*The contents of this document are subject to restrictions on disclosure as set forth herein.*

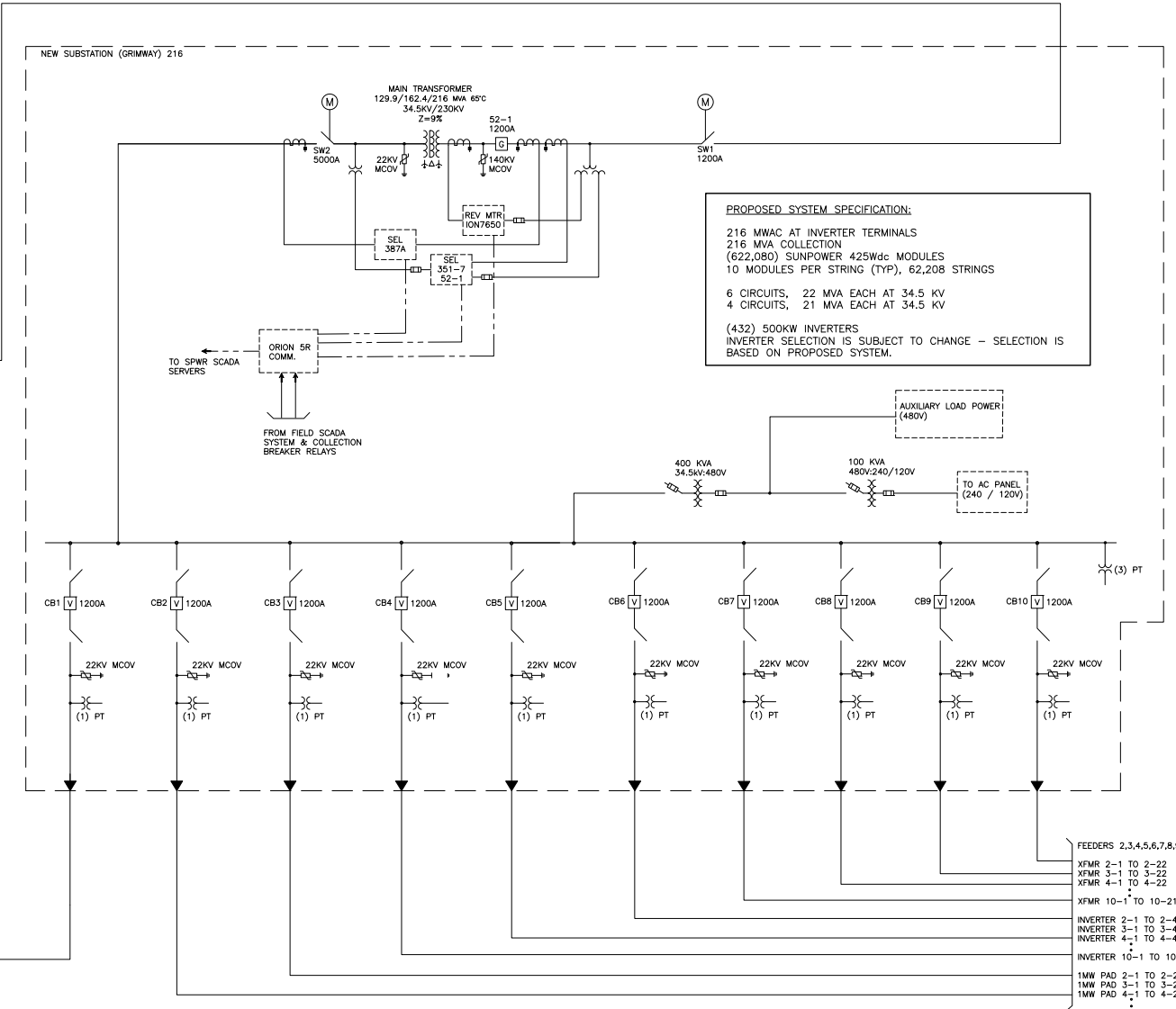
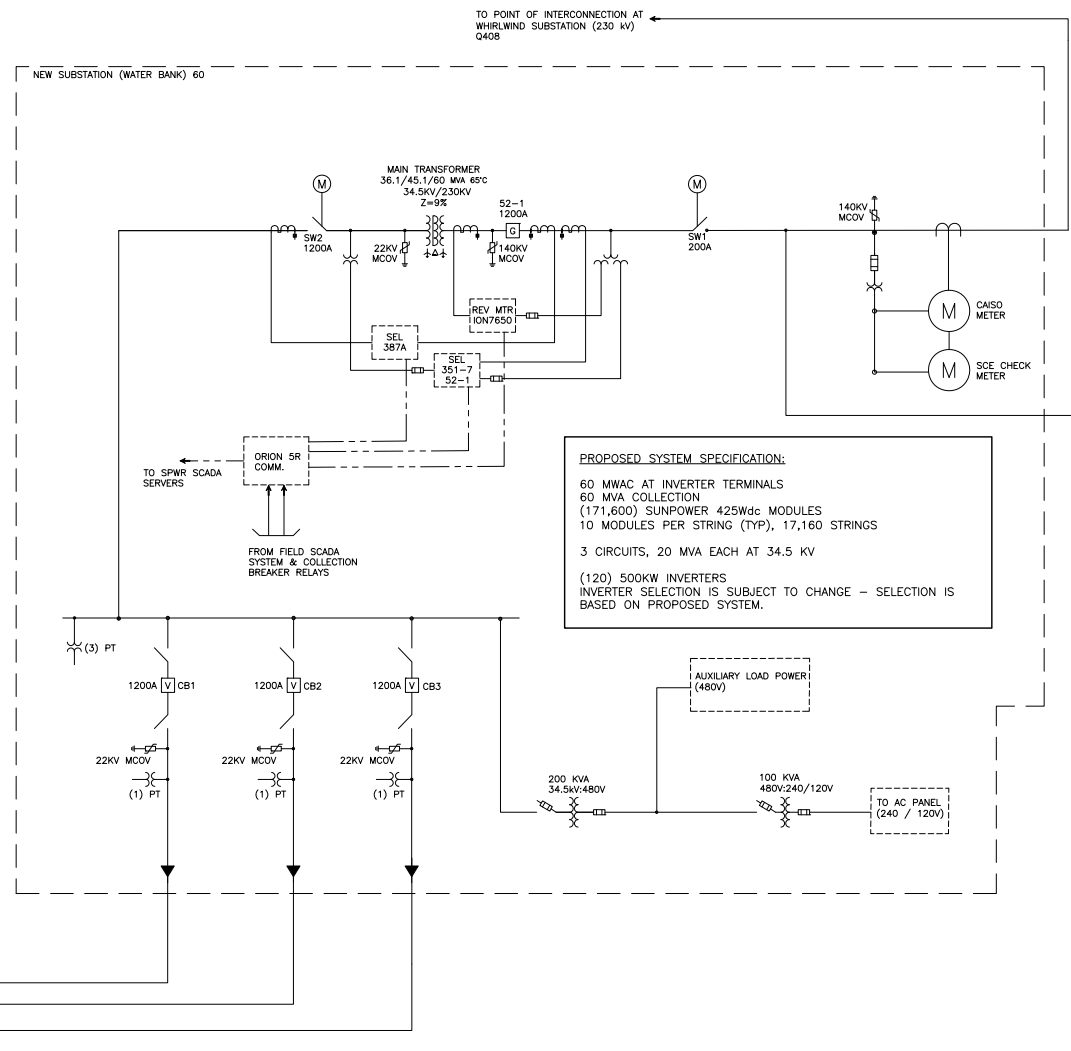

FEEDERS 1,2,3  
 XFMR 1-1 TO 1-20  
 XFMR 2-1 TO 2-20  
 XFMR 3-1 TO 3-20  
 INVERTER 1-1 TO 1-40  
 INVERTER 2-1 TO 2-40  
 INVERTER 3-1 TO 3-40  
 1MW PAD 1-1 TO 1-20  
 1MW PAD 2-1 TO 2-20  
 1MW PAD 3-1 TO 3-20

FEEDERS 2,3,4,5,6,7,8,9,10  
 XFMR 2-1 TO 2-22  
 XFMR 3-1 TO 3-22  
 XFMR 4-1 TO 4-22  
 XFMR 10-1 TO 10-21  
 INVERTER 2-1 TO 2-44  
 INVERTER 3-1 TO 3-44  
 INVERTER 4-1 TO 4-44  
 INVERTER 10-1 TO 10-42  
 1MW PAD 2-1 TO 2-22  
 1MW PAD 3-1 TO 3-22  
 1MW PAD 4-1 TO 4-22  
 1MW PAD 10-1 TO 10-21

**LEGEND:**

- MEDIUM VOLTAGE CIRCUIT BREAKER
- SURGE ARRESTER
- LOW VOLTAGE CIRCUIT BREAKER
- POWER TRANSFORMER
- CURRENT TRANSFORMER
- VOLTAGE TRANSFORMER
- FUSE SWITCH
- PHOTOVOLTAIC MODULE
- FAULT INDICATOR
- 600A DEAD BREAK ELBOW CONNECTION
- LOAD BREAK DISCONNECT SWITCH
- DC-AC INVERTER
- CONTACTOR

**INVERTER DATA:**  
 MANUFACTURER: TBD  
 RATED POWER: (pf = 1.0) 500kW  
 RATED VOLTAGE: 270Vac, 1000Vdc  
 APPARENT POWER: 500kVA  
 RATED FREQUENCY: 60HZ  
 RATED CURRENT OF INVERTER: 1070A

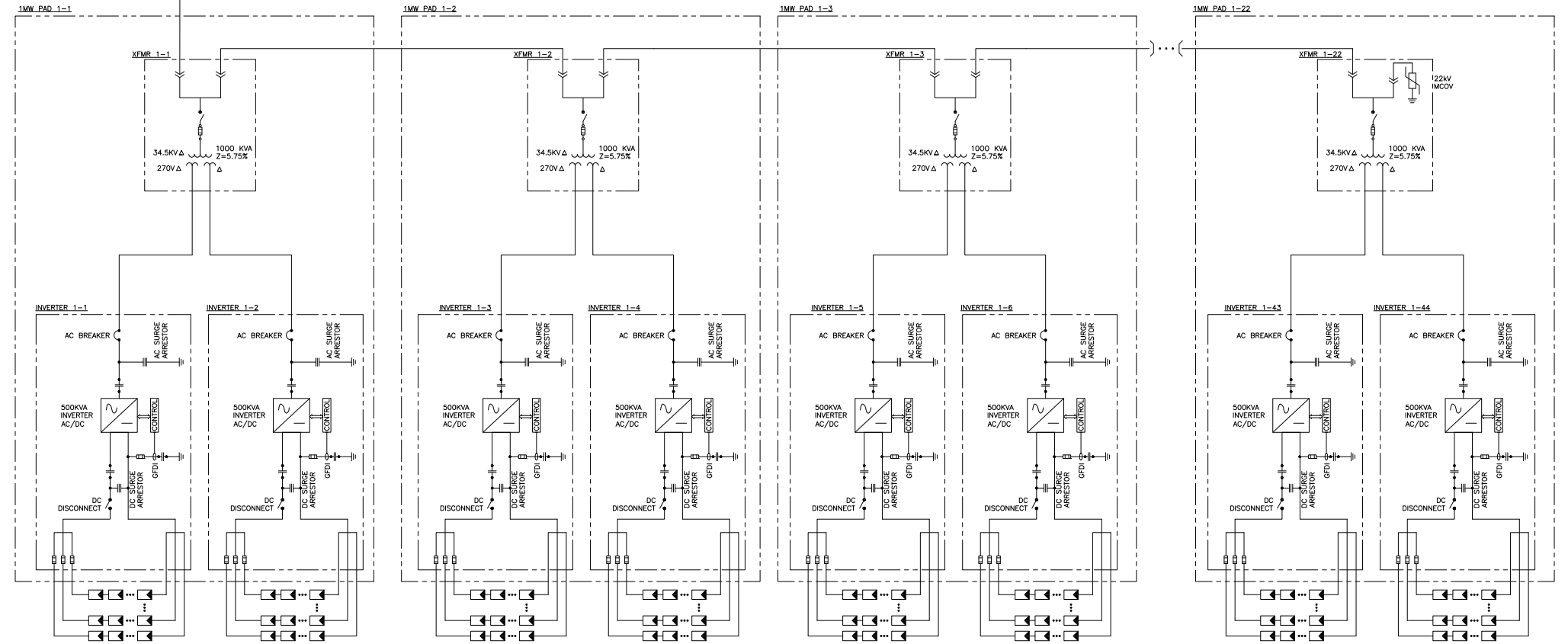

**SUNPOWER**  
 1414 HARBOUR WAY SOUTH  
 RICHMOND, CA 94804 USA  
 (510) 540-0550

ENGINEER'S STAMP

ANTELOPE VALLEY 2  
 SITE PLAN  
 PROPOSED ELECTRICAL  
 SINGLE-LINE SCHEMATIC

REV	DESIGN #	DATE	DESCRIPTION
A		08-11-10	PROPOSAL
B		08-11-10	TEXT CHANGE
C		10-06-10	TEXT CHANGE
D		10-08-10	AUXILIARY POWER ADDED
E	SL-0000893	10-19-10	SYSTEM SIZE CHANGED
F	SL-0000943	11-05-10	SYSTEM SIZE CHANGE
G		11-09-10	SYSTEM SIZE CHANGE AND SPECS ADDED
H	SL-0001031	12-7-10	SYSTEM SIZE CHANGE

OPPORTUNITY: 003739  
 PROJECT:  
 DATE DRAWN: 08-11-10  
 DRAWN BY: CHB

0 1/2" 1"  
 IF BAR IS NOT ONE INCH, DRAWING IS NOT TO SCALE  
 SHEET  
**E.2**

*\*\*\* End of EXHIBIT B \*\*\**

*The contents of this document are subject to restrictions on disclosure as set forth herein.*

## EXHIBIT C

### Notice List

<b>SOLAR STAR CALIFORNIA XX, LLC</b> ("Seller")	<b>SOUTHERN CALIFORNIA EDISON COMPANY</b> ("SCE")
All Notices are deemed provided in accordance with Section 10.08 if made to the address and facsimile numbers provided below:	Unless otherwise specified, all Notices are deemed provided in accordance with Section 10.08 if made to the Contract Sponsor at the address or facsimile number provided below:
<b>Contract Sponsor:</b> Attn: Ed Smeloff Street: 1414 Harbour Way South City: Richmond, CA 94804 Phone: (510) 540-0550 Facsimile: (510) 540-0554	<b>Contract Sponsor:</b> Attn: Vice-President, Renewable and Alternative Power Street: 2244 Walnut Grove Avenue City: Rosemead, California 91770 Phone: (626) 302-1212 Facsimile: (626) 302-1103
<b>Reference Numbers:</b> Duns: 18-3869563 Federal Tax ID Number: 20-8248962	<b>Reference Numbers:</b> Duns: 006908818 Federal Tax ID Number: 95-1240335
<b>Contract Administration:</b> Attn: Cathy Villareal Phone: (510) 540-0550 Facsimile: (510) 540-0554	<b>Contract Administration:</b> Attn: Matthew Langer Phone: (626) 302-3481 Facsimile: (626) 302-9622 E-Mail: Matthew.Langer@sce.com
<b>Forecasting:</b> Attn: Control Room Steve Hanawalt Phone: 1-800-251-9728 Facsimile: (510) 540-0554	<b>Generation Operations Center:</b> Phone: (626) 307-4453 or Phone: (626) 307-4410 E-mail:

The contents of this document are subject to restrictions on disclosure as set forth herein.



<p><b>SOLAR STAR CALIFORNIA XX, LLC</b> ("Seller")</p>	<p><b>SOUTHERN CALIFORNIA EDISON COMPANY</b> ("SCE")</p>
<p><b>Day-Ahead Forecasting:</b></p> <p>Steve Hanawalt Phone: 1-800-251-9728</p>	<p><b>Day-Ahead Scheduling:</b></p> <p><u>Manager.</u> Attn: Manager of Day-Ahead Operations Phone: (626) 302-1323 Facsimile: (626) 302-3409</p> <p><u>Scheduling Desk.</u> Phone: (626) 307-4425 Backup: (626) 307-4420 Fax: (626) 302-3409 E-mail: <a href="mailto:PreSched@SCE.com">PreSched@SCE.com</a></p>
<p><b>Real-Time Forecasting:</b></p> <p>Steve Hanawalt Phone: 1-800-251-9728</p>	<p><b>Real-Time Scheduling:</b></p> <p><u>Manager.</u> Attn: Manager of Real-Time Operations Phone: (626) 302-3308 Facsimile: (626) 302-3409</p> <p><u>Operations Desk.</u> Phone: (626) 307-4453 Back-up: (626) 307-4410 Fax: (626) 302-3409 E-mail: <a href="mailto:RealTime@SCE.com">RealTime@SCE.com</a></p>
	<p><b>Short Term Planning:</b></p>
<p><b>Payment Statements:</b></p> <p>Attn: Evan Popaduke Phone: (510) 540-0550 Facsimile: (510) 540-0554 E-mail:</p>	<p><b>Payment Statements:</b></p> <p>Attn: Power Procurement - Finance Phone: (626) 302-3277 Facsimile: (626) 302-3276 E-mail: <a href="mailto:PPFDPowerSettle@SCE.com">PPFDPowerSettle@SCE.com</a></p>
<p><b>CAISO Costs and CAISO Sanctions and SCE Penalties:</b></p> <p>Attn: Ken Mahaffey/Legal Department Phone: (510) 540-0550 Facsimile: (510) 540-0554 E-mail: <a href="mailto:ken.mahaffey@sunpowercorp.com">ken.mahaffey@sunpowercorp.com</a></p>	<p><b>CAISO Costs, CAISO Sanctions and SCE Penalties:</b></p> <p>Attn: Power Procurement - Finance Phone: (626) 302-3277 Facsimile: (626) 302-3276 E-mail: <a href="mailto:PPFDPowerSettle@SCE.com">PPFDPowerSettle@SCE.com</a></p>

The contents of this document are subject to restrictions on disclosure as set forth herein.

# Southern California Edison

Confidential Information

RAP ID# 5413, Solar Star California XX

<b>SOLAR STAR CALIFORNIA XX, LLC</b> ("Seller")	<b>SOUTHERN CALIFORNIA EDISON</b> <b>COMPANY ("SCE")</b>
<b>Payments:</b> Attn: Evan Popaduke Phone: (510) 540-0550 Facsimile: (510) 540-0554 E-mail:	<b>Payments:</b> Attn: Power Procurement - Finance Phone: (626) 302- Facsimile: (626) 302-3276 E-mail: <a href="mailto:PPFDPowerSettle@SCE.com">PPFDPowerSettle@SCE.com</a>
<b>Wire Transfer:</b> BNK: Bank of America ABA: 026009593 ACCT: 1233809538	<b>Wire Transfer:</b> BNK: JP Morgan Chase Bank ABA: 021000021 ACCT: 323-394434
<b>Credit and Collections:</b> Attn: Evan Popaduke Phone: (510) 540-0550 Facsimile: (510) 540-0554 E-mail:	<b>Manager of Credit and Collateral:</b> Attn: Manager of Credit Phone: (626) 302-1129 Facsimile: (626) 302-2517
<b>With additional Notices of an Event of Default or Potential Event of Default to:</b> Attn: Ken Mahaffey/Legal Department Phone: (510) 540-0550 Facsimile: (510) 540-0554 E-mail: <a href="mailto:ken.mahaffey@sunpowercorp.com">ken.mahaffey@sunpowercorp.com</a>	<b>With additional Notices of an Event of Default or Potential Event of Default to:</b> Attn: Manager SCE Law Department Power Procurement Section Phone: (626) 302-1212 Facsimile: (626) 302-1904
<b>Guarantor:</b> Attn: Phone: Facsimile: E-mail:	
<b>Lender:</b> Attn: Phone: Facsimile: E-mail:	

\*\*\* End of EXHIBIT C \*\*

The contents of this document are subject to restrictions on disclosure as set forth herein.

**EXHIBIT D***Forecasting and Scheduling Requirements and Procedures*1. Introduction.

The Parties shall abide by the Forecasting and Scheduling requirements and procedures described below and shall agree upon reasonable changes to these requirements and procedures from time-to-time, as necessary to:

- (a) Comply with CAISO Tariff changes;
- (b) Accommodate changes to their respective generation technology and organizational structure; and
- (c) Address changes in the operating and Scheduling procedures of both SCE and the CAISO, including but not limited to, automated forecast and outage submissions.

2. Seller's Forecasting Requirements.

Seller must meet all of the following requirements for Forecasting as specified below.

- (a) No later than sixty (60) days before any day designated for Initial Synchronization, Seller shall provide SCE, via the Web Client, with a 30-day, hourly Forecast of Capacity, in MW, as directed by SCE, for the thirty (30) day period commencing on Initial Synchronization.
- (b) If, after submitting the Forecast pursuant to Item 2(a), Seller learns that Initial Synchronization will occur on a date and time other than that reflected on the Forecast, Seller shall provide an updated Forecast reflecting the new Initial Synchronization date at the earliest practicable time but no later than 5:00 p.m. Pacific Prevailing Time ("PPT") on the Wednesday before the revised Initial Synchronization date, if Seller has learned of the new Initial Synchronization date by that time, but in no event less than three (3) Business Days before the actual Initial Synchronization date.
- (c) If the Web Client becomes unavailable, Seller shall provide SCE with the Forecast by e-mailing SCE.
- (d) The Forecast, and any updated Forecasts provided pursuant to this Item 2, must:
  - (i) Not include any anticipated or expected electric energy losses after the CAISO Approved Meter or Check Meter; and
  - (ii) Limit hour-to-hour Forecast changes to no less than two hundred fifty (250) kWh or 0.25 MW, as applicable, during any period when the Web Client is unavailable. Seller shall have no restriction on hour-to-hour Forecast changes when the Web Client is available.

*The contents of this document are subject to restrictions on disclosure as set forth herein.*

(e) Commencing on or before 5:00 p.m. PPT of the Wednesday before the first week covered by the Forecast provided pursuant to Item 2(a) above and on or before 5:00 p.m. PPT every Wednesday thereafter until the end of the Term, Seller shall update the Forecast for the thirty (30) day period commencing on the Sunday following the weekly Wednesday Forecast update submission. Seller shall use the Web Client, if available, to supply this weekly update or, if the Web Client is not available, Seller shall provide SCE with the weekly Forecast update by e-mailing SCE.

(f) Forecasting Available Capacity.

Seller is Forecasting available capacity, in accordance with SCE's instructions.

If:

- (i) Seller does not provide real-time communication of availability as provided in Section 3.08(g);
- (ii) The telecommunications path to obtain real-time data is inoperable; or
- (iii) Instrumentation is providing faulty or incorrect data; and

Seller learns of any change in the total available capacity of the Generating Facility for a period covered by the most recent Forecast update resulting from any cause, including an unplanned outage before the time that the next weekly update of the Forecast is due which Seller is required to report under the provisions of the CAISO Tariff related to PIRP and under other applicable provisions of the CAISO Tariff related to availability and outage reporting,

then Seller shall provide an updated Forecast to SCE. This updated Forecast must be submitted to SCE via the Web Client by no later than:

- a. 5:00 a.m. PPT on the day before any day impacted by the change, if the change is known to Seller at that time. If the Web Client is not available, Seller shall e-mail these changes to [presched@sce.com](mailto:presched@sce.com) and immediately follow up with a phone call to SCE's Day-Ahead Scheduling Desk in accordance with Exhibit C;
- b. Thirty (30) minutes before the commencement of any hour impacted by the change, if the change is known to Seller at that time; or
- c. If the change is not known to Seller by the timeframes indicated in (i) or (ii) above, within twenty (20) minutes after Seller becomes aware or, using best efforts, should have become aware of the event which caused the availability

change, e-mail changes to realtime@sce.com and immediately telephone SCE's Real-time Operations Desk in accordance with Exhibit C.

- (g) Seller's updated Forecast must reflect the following information:
  - (i) The beginning date and time of the change;
  - (ii) The expected ending date and time of the event;
  - (iii) The expected availability, in MW; and
  - (iv) Any other information required by the CAISO as communicated to Seller by SCE.

3. SCE's Scheduling Responsibilities.

SCE shall be responsible for Scheduling the Product in accordance with this Agreement.

4. Seller's Outage Scheduling Requirements.

Seller shall meet all requirements and timelines for generation outage scheduling contained in the CAISO's Scheduled and Forced Outage Procedure T-113, or its successor, as posted on the CAISO's website.

---

\*\*\* End of EXHIBIT D \*\*\*

**EXHIBIT E**

*Payments and Invoicing*

**A. COST RESPONSIBILITY, INVOICING AND PAYMENTS THROUGHOUT THE DELIVERY TERM**

1.01 Cost Responsibility for the Startup Period and upon commencement of the Term.

(a) SCE Cost Responsibility.

Throughout the Delivery Term,

- (i) Except under the circumstances set forth in Section 4.01(c), SCE shall make monthly Product Payments to Seller for Product delivered to SCE calculated in the manner described in Item 1.02 below and Exhibit Q;
- (ii) Except as set forth in Section 4.01(c) and Exhibit Q, SCE shall be responsible for all CAISO Costs and CAISO Sanctions and have the right to receive all CAISO Revenues; and
- (iii) To the extent that SCE requires Seller to participate in the PIRP program, SCE shall be responsible for PIRP forecasting fees.

(b) Seller Cost Responsibility.

Throughout the Delivery Term:

- (i) If Seller fails to comply with the Forecasting provisions set forth in Exhibit D, Seller shall pay an SCE Penalty as set forth in Exhibit Q.
- (ii) Seller shall be responsible for CAISO Costs and CAISO Sanctions under the circumstances specified in Sections 4.01(c) and 4.02(c) and Exhibit Q.

1.02 Product Payment Calculations during the Delivery Term.

For the purpose of calculating Product Payments for Product delivered during the Delivery Term, Metered Amounts will be time-differentiated according to the TOD Periods set forth in Exhibit K and the pricing will be weighted by the Product Payment Allocation Factors set forth in Exhibit K.

Monthly Product Payments will equal the sum of (i) the sum of the TOD Period Product Payments for all TOD Periods in the month and (ii) the Curtailed Product Payment. Each TOD Period Product Payment will be calculated pursuant to the following formula, where “n” is the TOD Period being calculated:

$$\text{TOD PERIOD}_n \text{ PRODUCT PAYMENT} = A \times B \times (C - D) \times E$$

Where:

*The contents of this document are subject to restrictions on disclosure as set forth herein.*

- A = Product Price specified in Exhibit O in \$/kWh (i.e., \$/MWh/1000), for the applicable Term Year.
- B = Product Payment Allocation Factor, set forth in Exhibit K, for the TOD Period being calculated.
- C = The sum of Metered Amounts in all hours for the TOD Period being calculated in kWh.
- D = Any electric energy produced by the Generating Facility for which SCE is not obligated to pay Seller as set forth in Section 4.01(c).
- E = Any applicable LF, in percent.

### 1.03 Payment Statement and Invoices during the Delivery Term.

Throughout the Delivery Term, no later than the 10<sup>th</sup> Business Day immediately following each calendar month during the Term Year during which: (w) Metered Amounts are provided to SCE; (x) CAISO Sanctions or any SCE Penalties are incurred by Seller; (y) there is Curtailed Product or OSGC Quantity; or (z) Adjustments for payment errors are made as set forth below; Seller shall send a Payment Invoice to SCE showing:

- (a) The Metered Amounts for each TOD Period during the month for which the payment is being made;
- (b) The amount of Curtailed Product and OSGC Quantity, if any;
- (c) A calculation of the amount payable to Seller for the month pursuant to Item 1.02 above of this Exhibit E; and
- (d) A calculation of the net amount due either to Seller or SCE.

### 1.04 Payment during the Delivery Term.

Throughout the Delivery Term, on or before the later of the last Business Day of the month in which SCE receives a Payment Invoice from Seller, or the tenth (10<sup>th</sup>) Business Day after receipt of the Payment Invoice, or, if such day is not a Business Day, then on the next Business Day, SCE shall:

- (a) Send to Seller, via wire transfer, SCE's payment of said net amount, less any applicable SCE Penalties, CAISO Costs or CAISO Sanctions per Exhibit Q, or other applicable charges or offsets plus, if such payment is late, a Simple Interest Payment calculated using the Interest Rate and the number of days that such payment is late;
- (b) If SCE, in good faith, Disputes the correctness of the Payment Invoice or a portion thereof, SCE will pay only the undisputed portion of the Payment Invoice and state, in writing, the basis for the Dispute. Payment of the Disputed portion of the Payment Invoice shall not be required until the Dispute is resolved. Upon resolution of the Dispute, any required payment

*The contents of this document are subject to restrictions on disclosure as set forth herein.*

shall be made within two (2) Business Days of such resolution along with interest accrued at the Interest Rate from and including the due date but excluding the date paid; and

- (c) Provide Seller with documentation supporting any SCE Penalty, CAISO Cost or CAISO Sanction, per Exhibit Q, or other applicable charges and offsets which affected the net amount in the Payment Invoice.

## **B. RECOMPUTATION, PAYMENT ADJUSTMENT AND NETTING RIGHTS**

### 2.01 Recomputation and Payment Adjustments.

- (a) If Seller or SCE determines that a calculation of Metered Amounts, CAISO Sanctions, or SCE Penalties is incorrect as a result of inaccurate meters, the correction of data by the CAISO in OMAR, or a recalculation of CAISO Sanctions, SCE Penalties or other amounts owing between the Parties, Seller or SCE, as the case may be, shall promptly recompute the Metered Amounts, CAISO Sanctions, SCE Penalties or other amounts for the period of the inaccuracy based upon an adjustment of inaccurate meter readings, correction of data or recalculation of CAISO Sanctions in accordance with the CAISO Tariff and any payment affected by the adjustment or correction.

In the event SCE believes that any CAISO Charge, CAISO Revenue, or CAISO Sanction is incorrect and disputable under the CAISO Tariff SCE may dispute any such CAISO Charge, CAISO Revenue, or CAISO Sanction in accordance with the procedures set forth under the CAISO Tariff.

- (b) Payment Adjustment.

Any amount due from SCE to Seller, or Seller to SCE, as the case may be, will be made as an adjustment to the next monthly payment statement that is calculated after Seller's or SCE's recomputation using corrected measurements.

If the recomputation results in a net amount owed to SCE after applying any amounts owing to Seller as shown on the next monthly payment statement, any such amount owing to SCE will at SCE's discretion be netted against amounts owed to Seller in any subsequent monthly Payment Invoice or separately invoiced to Seller, in which case Seller must pay the amount owing to SCE within twenty (20) days after receipt of that invoice.

SCE may make payment adjustments arising from a recalculation of CAISO Costs, CAISO Sanctions, SCE Penalties, or as a result of inaccurate meters after the end of the Term Year, *provided*, the Parties will be deemed to have waived any such payment adjustments which are not communicated as provided in this Item 2.01 of this Exhibit E within twelve (12) months after the end of the Term Year.



Adjustment payments for meter inaccuracy will not bear interest.

## 2.02 Netting Rights.

SCE reserves the right to net amounts that would otherwise be due to Seller under this Agreement in payment of any amounts:

- (a) Owing and unpaid by Seller to SCE under this Agreement; or
- (b) Owed to SCE by Seller arising out of, or related to, any other SCE agreement, tariff, obligation or liability.

Nothing in this Item 2.02 limits SCE's rights under applicable tariffs, other agreements or Applicable Law.

## C. PAYMENT ERRORS

### 3.01 Notice of Error in Payment.

Except as provided in Items 1.03 and 2.01 of this Exhibit E, if within ninety (90) days after receipt of SCE's Payment, Seller does not give SCE Notice of an error in the payment amount, then Seller will be deemed to have waived any error in the payment.

### 3.02 Reimbursement for Underpayments and Overpayments.

If Seller identifies a payment error in Seller's favor and SCE agrees that the identified error occurred, SCE shall reimburse Seller for the amount of the underpayment caused by the error and apply the additional payment to the next monthly Payment Invoice that is calculated.

If Seller identifies a payment error in SCE's favor and SCE agrees that the identified error occurred, SCE may net the amount of overpayment caused by the error against amounts otherwise owed to Seller in connection with the next monthly Payment Invoice that is calculated.

### 3.03 Late Payments.

Late payments to Seller resulting from SCE's errors, or overpayments to Seller by SCE, will include a Simple Interest Payment calculated using the Interest Rate and the number of days between the date due (or, in the case of overpayments by SCE, commencing five (5) Business Days from the date SCE provides Notice of such overpayments to Seller) and the date paid; *provided*, that changes made because of settlement, audit or other information provided by the CAISO and not available to SCE when SCE rendered its original Payment Invoice will not bear interest.

### 3.04 Netting after Recomputation.

If the recomputation for an error results in a net amount still owing to SCE after applying the amounts owed to SCE against any amounts owed to Seller in the payment statement, as described above, then SCE may, in its discretion, either net this

net remaining amount owed to SCE against amounts owed to Seller in any subsequent monthly Payment Invoice to Seller or invoice Seller for such amount, in which case Seller must pay the amount owing to SCE within twenty (20) days after receipt of such invoice.

3.05 Resolution of Disputes.

The Parties shall negotiate in good faith to resolve any disputes regarding claimed errors in a Payment. Any disputes which the Parties are unable to resolve through negotiation may be submitted for resolution through the mediation and arbitration as provided in Article Twelve.

---

\*\*\* End of EXHIBIT E \*\*\*

## EXHIBIT F

### *Product Replacement Damage Amount*

In accordance with the provisions of Section 3.07, if at the end of any Term Year, commencing with the end of the second Term Year, Seller fails to meet Seller's Energy Delivery Obligation over the Calculation Period, *then* Seller shall be subject to a Product Replacement Damage Amount penalty calculated as follows:

PRODUCT REPLACEMENT DAMAGE AMOUNT =

$$[(A - B - C) \times (D - E)]$$

Where:

- A = Seller's Energy Delivery Obligation in kWh.
- B = Sum of Qualified Amounts over the Calculation Period in kWh.
- C = Sum of Lost Output over the Calculation Period in kWh.
- D = Simple average of the Green Market Price for all Settlement Intervals during the Calculation Period in \$/kWh.
- E = Simple average of the Product Price over the Calculation Period, in \$/kWh (i.e., \$/MWh/1000).

Notes:

1. In the above calculation, the result of "(D - E)" will not be greater than five cents (\$0.05) per kWh or less than two cents (\$0.02) per kWh.
2. In no event will SCE pay a Product Replacement Damage Amount.

---

\*\*\* End of EXHIBIT F \*\*\*

**EXHIBIT G-1**  
*Seller's Milestone Schedule*

<i>No.</i>	<i>Date</i>	<i>Milestones</i>
1	09/05/2008	Submits interconnection application.
2	07/24/2009	Receives a completed Phase I Interconnection Study.
3	03/31/2010	Obtains control of all lands and rights-of-way comprising the Site.
4	03/15/2010	Files Construction Permit application(s).
5	08/31/2010	Receives a completed Phase II Interconnection Study.
6	12/15/2010	Files a CEC Pre-Certification application.
7	03/01/2011	Executes an interconnection agreement and transmission service agreement.
8	03/15/2011	Receives CEC Pre-Certification.
9	05/01/2011	Receives FERC acceptance of interconnection agreement and transmission agreement.
10	03/15/2013	Receives Construction Permit.
11	04/15/2013	Files Material Permit applications.
12	10/15/2013	Receives Material Permits.
13	12/01/2013	Initial Synchronization Date.
14	06/15/2014	Executes an Engineering, Procurement and Construction ("EPC") contract.
15	07/15/2014	Close of Construction Financing.
16	08/15/2014	Groundbreaking of the Generating Facility.
17	10/31/2016	Commercial Operation Date.
18	11/30/2016	Demonstrates Contract Capacity.
19	11/30/2016	Files an application or other appropriate request with the CEC for CEC Certification.
20	12/31/2016	Receives CEC Certification.

*The contents of this document are subject to restrictions on disclosure as set forth herein.*

**EXHIBIT G-2**  
*Seller's Material Permits*

<i>No.</i>	<i>Permits</i>
1	Conditional Use Permit and Acceptance of Final Conditions
2	Dust Control Permit
3	Stormwater Pollution Prevention Plan
4	Certificate of Occupancy
5	Grading Permit
6	Building Permit
7	Trailer Permit
8	Right of Way and Road Use
9	Septic Permit
10	Water Permit

---

*\*\*\* End of EXHIBIT G \*\*\**

**EXHIBIT H***Milestone Progress Reporting Form*

Seller shall prepare a written report on its progress relative to the development, construction and startup of the Generating Facility and the Milestone Schedule (i) quarterly, between the Effective Date and the date that Seller receives its Construction Permits, and monthly thereafter; or (ii) upon SCE's reasonable request. The report must be sent via e-mail in the form of a single Adobe Acrobat file or facsimile to SCE's Contract Administration, as noted in Exhibit C, on the fifth (5th) Business Day after each quarter or each month, as applicable.

Seller's obligation to complete a Milestone Progress Reporting Form for the preceding quarter or month, as applicable and submit such report to SCE begins on the first day of the first quarter after the Effective Date of this Agreement and ends immediately after a Milestone Progress Reporting Form is completed and submitted for the month in which the Firm Operation Date occurs.

Each Milestone Progress Report must include the following items:

1. Cover page.
2. Brief Generating Facility description.
3. Site plan of the Generation Facility.
4. Description of any planned changes to the Generating Facility and Site Description in Exhibit B-1.
5. Bar chart schedule showing progress on achieving the Milestone Schedule.
6. PERT or GANT chart showing critical path schedule of major items and activities.
7. Summary of activities during the previous month.
8. Forecast of activities scheduled for the current month.
9. Written description about the progress relative to Seller's Milestone Schedule.
10. List of issues that could potentially impact Seller's Milestone Schedule.
11. Enumeration and schedule of any support or actions requested of SCE.
12. Progress and schedule of all agreements, contracts, Permits, approvals, technical studies, financing agreements and major equipment purchase orders showing the start dates, completion dates, and completion percentages.
13. A status report of start-up activities including a forecast of activities ongoing and after start-up, a report on Generating Facility performance including performance projections for the next twelve (12) months.
14. Pictures, in sufficient quantity and of appropriate detail, in order to document construction and startup progress of the Generating Facility, Transmission Provider's electric system and all other interconnection utility services.

*The contents of this document are subject to restrictions on disclosure as set forth herein.*

*\*\*\* End of EXHIBIT H \*\*\**

## **EXHIBIT I**

### *Form of Guaranty Agreement*

1. Guaranty.

For valuable consideration, [Guarantor's legal name], [legal status] (“**Guarantor**”) guarantees payment to Southern California Edison Company, a California corporation (“**Beneficiary**”), its successors and assigns, of all amounts owed to Beneficiary by [Seller's legal name], [legal status] (“**Principal**”) under that certain Renewable Power Purchase and Sale Agreement between Beneficiary and Principal dated [date], as amended from time to time (“**Agreement**”) (said amounts are hereinafter referred to as the “**Obligations**”).

Initially capitalized words that are used but not otherwise defined in this agreement (“**Guaranty**”) shall have the meanings given them in the Agreement.

Upon the failure or refusal by Principal to pay all or any portion of the Obligations, the Beneficiary may make a demand upon the Guarantor.

Such demand shall be in writing and shall state the amount Principal has failed to pay and an explanation of why such payment is due, with a specific statement that Beneficiary is calling upon Guarantor to pay under this Guaranty.

Guarantor shall promptly, but in no event less than ten Business Days following demand by Beneficiary, pay such Obligations in immediately available funds.

The obligations of Guarantor hereunder shall not be subject to any counterclaim, setoff, withholding, or deduction unless required by applicable law.

A payment demand satisfying the foregoing requirements shall be deemed sufficient notice to Guarantor that it must pay the Obligations.

2. Guaranty Limit.

Subject to Paragraph 13, the liability of Guarantor hereunder shall not exceed \$\_\_\_\_\_ in the aggregate, which amount shall include all interest that has accrued on any amount owed hereunder.

3. Guaranty Absolute.

Guarantor agrees that its obligations under this Guaranty are irrevocable, absolute, independent and unconditional and shall not be affected by any circumstance which constitutes a legal or equitable discharge of a guarantor. In furtherance of the foregoing and without limiting the generality thereof, Guarantor agrees as follows:

- (a) The liability of Guarantor under this Guaranty is a continuing guaranty of payment and not of collectibility, and is not conditional or contingent upon the genuineness, validity, regularity or enforceability of the Agreement or the pursuit by Beneficiary of any remedies which it now has or may hereafter have under the Agreement;

*The contents of this document are subject to restrictions on disclosure as set forth herein.*



- (b) Beneficiary may enforce this Guaranty upon the occurrence of a default by Principal under the Agreement notwithstanding the existence of a dispute between Beneficiary and Principal with respect to the existence of the default;
- (c) The obligations of Guarantor under this Guaranty are independent of the obligations of Principal under the Agreement and a separate action or actions may be brought and prosecuted against Guarantor whether or not any action is brought against Principal or any other guarantors and whether or not Principal is joined in any such action or actions;
- (d) Beneficiary may, at its election, foreclose on any security held by Beneficiary, whether or not the means of foreclosure is commercially reasonable, or exercise any other right or remedy available to Beneficiary without affecting or impairing in any way the liability of Guarantor under this Guaranty, except to the extent the amount(s) owed to Beneficiary by Principal have been paid; and
- (e) Guarantor shall continue to be liable under this Guaranty and the provisions hereof shall remain in full force and effect notwithstanding:
  - (i) Any modification, amendment, supplement, extension, agreement or stipulation between Principal and Beneficiary or their respective successors and assigns, with respect to the Agreement or the obligations encompassed thereby;
  - (ii) Beneficiary's waiver of or failure to enforce any of the terms, covenants or conditions contained in the Agreement;
  - (iii) Any release of Principal or any other guarantor from any liability with respect to the Obligations or any portion thereof;
  - (iv) Any release, compromise or subordination of any real or personal property then held by Beneficiary as security for the performance of the Obligations or any portion thereof, or any substitution with respect thereto;
  - (v) Without in any way limiting the generality of the foregoing, if Beneficiary is awarded a judgment in any suit brought to enforce a portion of the Obligations, such judgment shall not be deemed to release Guarantor from its covenant to pay that portion of the Obligations which is not the subject of such suit;
  - (vi) Beneficiary's acceptance and/or enforcement of, or failure to enforce, any other guaranties or any portion of this Guaranty;
  - (vii) Beneficiary's exercise of any other rights available to it under the Agreement;

- (viii) Beneficiary's consent to the change, reorganization or termination of the corporate structure or existence of the Principal and to any corresponding restructuring of the Obligations;
- (ix) Any failure to perfect or continue perfection of a security interest in any collateral that secures the Obligations;
- (x) Any defenses, setoffs or counterclaims that Principal may allege or assert against Beneficiary with respect to the Obligations, including, without limitation, failure of consideration, breach of warranty, statute of frauds, statute of limitations and accord and satisfaction; and
- (xi) Any other act or thing or omission, or delay to do any other act or thing that might in any manner or to any extent vary the risk of Guarantor as an obligor with respect to the Obligations.

4. Termination; Reinstatement.

- (a) The term of this Guaranty is continuous until the earlier of: (i) the date on which the Obligations have been performed or paid in full or (ii) with regard to future transactions, the date on which Guarantor provides Beneficiary with written notice of termination, with such termination becoming effective sixty (60) calendar days from the date Beneficiary receives such written notice from Guarantor.

No such notice or termination shall release Guarantor from any liability as to any amount or performance that is owing under the Agreement as of the termination date.

- (b) This Guaranty shall be reinstated if at any time following the termination of this Guaranty, any payment by Guarantor under this Guaranty or pursuant hereto is rescinded or must otherwise be returned by the Beneficiary or other person upon the insolvency, bankruptcy, reorganization, dissolution or liquidation of Principal, Guarantor or otherwise, and is so rescinded or returned to the party or parties making such payment, all as though such payment had not been made.

If all or any portion of the Obligations are paid by Principal, the obligations of Guarantor hereunder shall continue and remain in full force and effect or be reinstated, as the case may be, If all or any part of such payment(s) are rescinded or recovered directly or indirectly from Beneficiary as a preference, fraudulent transfer or otherwise, and any such payments which are so rescinded or recovered shall constitute Obligations for all purposes under this Guaranty.

5. Bankruptcy; Post-Petition Interest.

- (a) So long as any Obligations remain outstanding, Guarantor shall not, without the prior written consent of Beneficiary, commence or join with any other

person in commencing any bankruptcy, reorganization or insolvency proceedings of or against Principal.

The obligations of Guarantor under this Guaranty shall not be reduced, limited, impaired, discharged, deferred, suspended or terminated by any proceeding, voluntary or involuntary, involving the bankruptcy, insolvency, receivership, reorganization, liquidation or arrangement of the Principal or by any defense which Principal may have by reason of the order, decree or decision of any court or administrative body resulting from any such proceeding.

- (b) Any interest on any portion of the Obligations which accrues after the commencement of any such proceeding (or, if interest on any portion of the Obligations ceases to accrue by operation of law by reason of the commencement of said proceeding, such interest as would have accrued on such portion of the Obligations if said proceedings had not been commenced) shall be included in the Obligations.

Guarantor will permit any trustee in bankruptcy, receiver, debtor in possession, assignee for the benefit of creditors or similar person to pay Beneficiary, or allow the claim of Beneficiary in respect of, any such interest accruing after the date on which such proceeding is commenced.

6. Subrogation.

Guarantor shall be subrogated to all rights of the Beneficiary against Principal with respect to any amounts paid by the Guarantor pursuant to the Guaranty, *provided that* Guarantor postpones all subrogation rights until all Obligations have been irrevocably paid in full to the Beneficiary.

If any amount shall be paid to Guarantor on account of such subrogation, reimbursement, contribution or indemnity rights at any time when all the Obligations guaranteed hereunder shall not have been indefeasibly paid in full, Guarantor shall hold such amount in trust for the benefit of Beneficiary and shall promptly pay such amount to Beneficiary.

7. Subordination.

- (a) Any indebtedness of Principal now or hereafter held by Guarantor is hereby subordinated in right of payment to the Obligations.

Guarantor assigns all such indebtedness to Beneficiary as security for this Guaranty and the Agreement.

Guarantor shall make no claim for such indebtedness until all Obligations of Principal have been fully discharged.

Guarantor shall not assign all or any part of such indebtedness unless Beneficiary is given prior notice and such assignment is expressly made subject to the terms of this Guaranty.

*The contents of this document are subject to restrictions on disclosure as set forth herein.*

- (b) If Beneficiary so requests:
  - (i) All instruments evidencing such indebtedness shall be duly endorsed and delivered to Beneficiary;
  - (ii) All security for such indebtedness shall be duly assigned and delivered to Beneficiary;
  - (iii) Such indebtedness shall be enforced, collected and held by Guarantor as trustee for Beneficiary and shall be paid over to Beneficiary on account of the Obligations but without reducing or affecting in any manner the liability of Guarantor under the other provisions of this Guaranty; and
  - (iv) Guarantor shall execute, file and record such documents and instruments and take such other actions as Beneficiary deems necessary or appropriate to perfect, preserve and enforce Beneficiary's rights in and to such indebtedness and any security therefor.
- (c) If Guarantor fails to take any such action, Beneficiary, as attorney-in-fact for Guarantor, is hereby authorized to do so in the name of Guarantor.

The foregoing power of attorney is coupled with an interest and cannot be revoked.

8. Waivers of Guarantor.

- (a) Guarantor waives, to the fullest extent permitted by law, the benefit of any statute of limitations affecting its liability under this Guaranty or the enforcement of this Guaranty.
- (b) Guarantor waives any right to require Beneficiary to proceed against or exhaust any security held from Principal or any other party acting under a separate agreement.
- (c) Guarantor waives all of the rights and defenses described in subdivision (a) of Section 2856 of the California Civil Code, including any rights and defenses that are or may become available to the Guarantor by reason of Sections 2787 to 2855 thereof, inclusive. Without limiting the generality of the foregoing waiver:
  - (i) The guarantor waives all rights and defenses that the guarantor may have because the debtor's debt is secured by real property.

This means, among other things:

- a. The creditor may collect from the guarantor without first foreclosing on any real or personal property collateral pledged by the debtor.
- b. If the creditor forecloses on any real property collateral pledged by the debtor:

*The contents of this document are subject to restrictions on disclosure as set forth herein.*

- (1) The amount of the debt may be reduced only by the price for which that collateral is sold at the foreclosure sale, even if the collateral is worth more than the sale price.
- (2) The creditor may collect from the guarantor even if the creditor, by foreclosing on the real property collateral, has destroyed any right the guarantor may have to collect from the debtor.

This is an unconditional and irrevocable waiver of any rights and defenses the guarantor may have because the debtor's debt is secured by real property. These rights and defenses include, but are not limited to, any rights or defenses based upon Section 580a, 580b, 580d, or 726 of the California Code of Civil Procedure.

- (ii) The guarantor waives all rights and defenses arising out of an election of remedies by the creditor, even though that election of remedies, such as a nonjudicial foreclosure with respect to security for a guaranteed obligation, has destroyed the guarantor's rights of subrogation and reimbursement against the principal by the operation of Section 580d of the Code of Civil Procedure or otherwise.
- (d) Guarantor assumes all responsibility for keeping itself informed of Principal's financial condition and all other factors affecting the risks and liability assumed by Guarantor hereunder, and Beneficiary shall have no duty to advise Guarantor of information known to it regarding such risks.
- (e) Guarantor waives any defense arising by reason of the incapacity, lack of authority or any disability or other defense of the Principal, including, without limitation, any defense based on or arising out of the lack of validity or enforceability of the Obligations or by reason of the cessation of liability of the Principal under the Agreement for any reason other than full performance or payment;
- (f) Guarantor waives any defense based upon Beneficiary's errors or omissions in the administration of the Obligations;
- (g) Guarantor waives its right to raise any defenses based upon promptness, diligence, and any requirement that Beneficiary protect, secure, perfect or insure any security interest or lien or any property subject thereto;
- (h) Guarantor waives its right to raise any principles of law, statutory or otherwise, that limit the liability of or exonerate guarantors, provide any legal or equitable discharge of Guarantor's obligations hereunder, or which may conflict with the terms of this Guaranty;
- (i) Other than demand for payment, the Guarantor hereby expressly waives all notices between the Beneficiary and the Principal including without limitation

*The contents of this document are subject to restrictions on disclosure as set forth herein.*

all notices with respect to the Agreement and this Guaranty, notice of acceptance of this Guaranty, any notice of credits extended and sales made by the Beneficiary to Principal, any information regarding Principal's financial condition, and all other notices whatsoever; and

- (j) Guarantor waives filing of claims with a court in the event of the insolvency or bankruptcy of the Principal.

9. No Waiver of Rights by Beneficiary.

No right or power of Beneficiary under this Guaranty shall be deemed to have been waived by any act or conduct on the part of Beneficiary, or by any neglect to exercise a right or power, or by any delay in doing so, and every right or power of Beneficiary hereunder shall continue in full force and effect until specifically waived or released in a written document executed by Beneficiary.

10. Assignment, Successors and Assigns.

This Guaranty shall be binding upon Guarantor, its successors and assigns, and shall inure to the benefit of, and be enforceable by, the Beneficiary and its successors, assigns and creditors.

The Beneficiary shall have the right to assign this Guaranty to any person or entity without the prior consent of the Guarantor; *provided, however*, that no such assignment shall be binding upon the Guarantor until it receives written notice of such assignment from the Beneficiary.

The Guarantor shall have no right to assign this Guaranty or its obligations hereunder without the prior written consent of the Beneficiary.

11. Representations of Guarantor.

Guarantor hereby represents and warrants that:

- (a) It is a corporation duly organized, validly existing and in good standing in all necessary jurisdictions and has full power and authority to execute, deliver and perform this Guaranty;
- (b) It has taken all necessary actions to execute, deliver and perform this Guaranty;
- (c) This Guaranty constitutes the legal, valid and binding obligation of Guarantor, enforceable in accordance with its terms, subject to bankruptcy, insolvency, reorganization, moratorium and other similar laws effecting creditors' rights generally and to general equitable principles;
- (d) Execution, delivery and performance by Guarantor of this Guaranty does not conflict with, violate or create a default under any of its governing documents, any agreement or instruments to which it is a party or to which any of its assets is subject or any applicable law, rule, regulation, order or judgment of any Governmental Authority; and

- (e) All consents, approvals and authorizations of governmental authorities required in connection with Guarantor's execution, delivery and performance of this Guaranty have been duly and validly obtained and remain in full force and effect.

12. Financial Statements.

- (a) If requested by Beneficiary, Guarantor shall deliver the following financial statements, which in all cases shall be for the most recent accounting period and prepared in accordance with generally accepted accounting principles:
  - (i) Within one hundred-twenty (120) days following the end of each fiscal year that any Obligations are outstanding, a copy of its annual report containing its audited consolidated financial statements (income statement, balance sheet, statement of cash flows and statement of retained earnings and all accompanying notes) for such fiscal year, setting forth in each case in comparative form the figures for the previous year; and
  - (ii) Within sixty (60) days after the end of each of its first three fiscal quarters of each fiscal year that any Obligations are outstanding, a copy of its quarterly report containing its consolidated financial statements (income statement, balance sheet, statement of cash flows and statement of retained earnings and all accompanying notes) for such fiscal quarter and the portion of the fiscal year through the end of such quarter, setting forth in each case in comparative form the figures for the previous year and:
    - (1) Certified in accordance with all applicable laws and regulations, including all applicable Securities and Exchange Commission ("SEC") rules and regulations, if Guarantor is an SEC reporting company; or
    - (2) Certified by a Responsible Officer as being fairly stated in all material respects (subject to normal year end audit adjustments) if Guarantor is not an SEC reporting company.
- (b) For the purposes of the requirement in this Paragraph 12, if Guarantor's financial statements are publicly available electronically on the website of Guarantor or the SEC, then Guarantor shall be deemed to have met this requirement.

13. Attorneys' Fees.

In addition to the amounts for which payment is guaranteed hereunder, Guarantor agrees to pay reasonable attorneys' fees and all other costs and expenses incurred by Beneficiary in enforcing this Guaranty or in any action or proceeding arising out of or relating to this Guaranty.

Any costs for which Guarantor becomes liable pursuant to this Paragraph 13 shall not be subject to, and shall not count toward, the guaranty limit set forth in Paragraph 2 above.

14. Governing Law.

This Guaranty is made under and shall be governed in all respects by the laws of the State of California, without regard to conflict of law principles.

If any provision of this Guaranty is held invalid under the laws of California, this Guaranty shall be construed as though the invalid provision has been deleted, and the rights and obligations of the parties shall be construed accordingly.

15. Construction.

All parties to this Guaranty are represented by legal counsel.

The terms of this Guaranty and the language used in this Guaranty shall be deemed to be the terms and language chosen by the parties hereto to express their mutual intent.

This Guaranty shall be construed without regard to any presumption or rule requiring construction against the party causing such instrument or any portion thereof to be drafted, or in favor of the party receiving a particular benefit under this Guaranty.

No rule of strict construction will be applied against any party.

16. Amendment; Severability.

Neither this Guaranty nor any of the terms hereof may be terminated, amended, supplemented or modified, except by an instrument in writing executed by an authorized representative of each of Guarantor and Beneficiary.

If any provision in or obligation under this Guaranty shall be invalid, illegal or unenforceable in any jurisdiction, the validity, legality and enforceability of the remaining provisions or obligations, or of such provision or obligation in any other jurisdiction, shall not in any way be affected or impaired thereby.

17. Third Party Rights.

This Guaranty shall not be construed to create any rights in any parties other than Guarantor and Beneficiary and their respective successors and permitted assigns.

18. Notices.

Any demand for payment, notice, request, instruction, correspondence or other document to be given hereunder by any party to another shall be made by facsimile to the person and at the address for notices specified below.

Beneficiary:

Southern California Edison Company

2244 Walnut Grove Avenue

Rosemead, CA 91770

Attn: [Credit Manager]

*The contents of this document are subject to restrictions on disclosure as set forth herein.*



Phone: (626) 302-  
Facsimile: (626) 302-

with a copy to:

Southern California Edison Company  
2244 Walnut Grove Avenue, Quad 4-D  
Rosemead, CA 91770

Attn: Manager, Renewable and Alternative Power  
Phone: (626) 302-  
Facsimile: (626) 302-

with an additional copy to:

Southern California Edison Company  
2244 Walnut Grove Avenue, Quad 3-B  
Rosemead, CA 91770

Attn: Manager, Power Procurement Section, Law Dept  
Phone: (626) 302-  
Facsimile: (626) 302-

Guarantor:

*[Guarantor]*  
*[Street]*  
*[City, State Zip]*

Attn:  
Phone:  
Facsimile:

Principal:

*[Principal]*  
*[Street]*  
*[City, State Zip]*

Attn:  
Phone:  
Facsimile:

Such notice shall be effective upon confirmation of the actual receipt if received during the recipient's normal business hours, or at the beginning of the recipient's next Business Day after receipt if receipt is outside of the recipient's normal business hours. Either party may periodically change any address to which notice is to be given it by providing notice of such change as provided herein.

IN WITNESS WHEREOF, Guarantor has executed this Guaranty as of \_\_\_\_\_, \_\_\_\_.

\_\_\_\_\_ *[legal name]*

By: \_\_\_\_\_

Name: \_\_\_\_\_

Title: \_\_\_\_\_

Date: \_\_\_\_\_

---

\*\*\* *End of EXHIBIT I* \*\*\*

**EXHIBIT J**

*Non-Disclosure Agreement*

*The contents of this document are subject to restrictions on disclosure as set forth herein.*

# SUNPOWER

January 3, 2011

Southern California Edison Company  
2244 Walnut Grove Avenue  
Rosemead, CA 91770

Attn: Vice President, Renewable and Alternative Power

Reference is made to that certain Non-Disclosure Agreement between SunPower Corporation, Systems ("SunPower"), a Delaware corporation and Southern California Edison Company ("SCE"), a California corporation, dated on or about August 21, 2009, and attached hereto (the "NDA").

SCE and SunPower wish to add Solar Star California XX, LLC ("Seller") as a Party to the NDA and Seller wishes to become a Party to the NDA.

This letter agreement confirms that Seller shall be added as a party to the NDA and Seller has read the attached NDA, and agrees to be bound by the NDA along with and to the same extent as SunPower, and agrees to make all of the terms and conditions contained in the NDA with respect to SunPower legally enforceable against Seller.

Sincerely,

Solar Star California XX, LLC

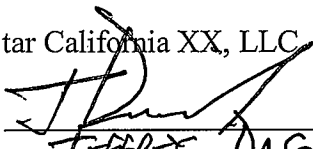
By:   
Name: JEFFREY DASOVITCH  
Title: MANAGING DIRECTOR

Agreed and accepted this 3rd day of January 2011.

SOUTHERN CALIFORNIA EDISON COMPANY

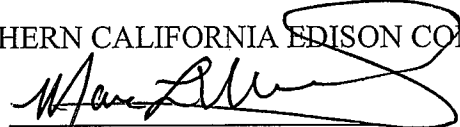
By:   
Name: Marc L. Ulrich  
Title: Vice President of Renewable and Alternative Power

APPROVED STEPHEN E. PICKETT Sr. Vice President and General Counsel	
By: 	Attorney
January 4, 2011	

## NON-DISCLOSURE AGREEMENT

Between

SOUTHERN CALIFORNIA EDISON COMPANY

and

SUNPOWER CORPORATION, SYSTEMS

This Non-Disclosure Agreement (“Agreement”) dated as of August 21 , 2009 (“Effective Date”) is hereby entered into by and between SOUTHERN CALIFORNIA EDISON COMPANY (“SCE”), a California corporation, and SUNPOWER CORPORATION, SYSTEMS (“SunPower”), a Delaware corporation.

SCE and SunPower shall sometimes be referred to in this Agreement individually as a “Party” and jointly as the “Parties.”

### RECITALS

- A. SCE initiated a request for proposals (“RFP”) to supply energy and associated Green Attributes, Capacity Attributes and Resource Adequacy Benefits from eligible renewable resources (“ERRs”) on June 29, 2009, with a goal of negotiating and executing power purchase agreements with ERRs whose proposals are selected pursuant to the RFP.
- B. SunPower desires to submit a proposal in response to the RFP.
- C. The Parties desire to keep confidential any confidential or proprietary information disclosed by SunPower to SCE as part of SunPower’s submission of a proposal in response to the RFP (the “Proposal”), or any confidential or proprietary information that may be disclosed by either Party to the other Party as part of discussions or negotiations with SunPower concerning SunPower’s Proposal.

## AGREEMENT

NOW, THEREFORE, the Parties agree as follows:

1. For purposes of this Agreement, all oral or written (including electronic) communications exchanged between the Parties on or after the Effective Date (as set forth in Section 10 of this Agreement) as part of, or arising out of, the Proposal (including the fact that SunPower has submitted the Proposal and, if applicable, the facts that: (i) SCE has short-listed the Proposal; and (ii) the Parties are negotiating the Proposal) shall be referred to as "Confidential Information."
2. Each Party agrees to treat Confidential Information as confidential with respect to third parties and shall not disclose Confidential Information except as specifically authorized herein or as specifically agreed to by each Party in writing.

Accordingly, each Party must take all necessary precautions and implement all requisite procedures and practices to protect Confidential Information provided by the other Party. Each Party may disclose Confidential Information only to its employees, directors, advisors, attorneys, consultants or accountants who have a strict need to know solely for the purpose of directly assisting such disclosing Party in evaluating the Proposal ("Permitted Disclosee"), or in subsequent discussions or negotiations regarding the Proposal and so long as such disclosing Party advises each Permitted Disclosee of the confidential nature of the Confidential Information and uses reasonable efforts to prevent or limit the disclosure of Confidential Information by such Permitted Disclosee. In addition, the Independent Evaluator (as described in that certain Procurement Protocol for SCE's 2009 Request for Proposals from Eligible Renewable Energy Resource Suppliers for Electric Energy) is and must be deemed to be a Permitted Disclosee.

Each Party may also disclose Confidential Information to representatives of its rating agencies who have a strict need to know solely for the purpose of directly assisting such disclosing Party in evaluating the Proposal, so long as such disclosing Party advises the rating agency of the confidential nature of the Confidential Information and uses reasonable efforts to prevent or limit the disclosure of Confidential Information by any such rating agency.

3. SCE and the Independent Evaluator may also disclose Confidential Information to the following entities and their staff and divisions thereof in furtherance of the RFP: (i) the California Public Utilities Commission ("CPUC"), (ii) the Procurement Review Group established pursuant to D.02-08-071 and D.03-06-071 ("PRG"), (iii) the California Energy Commission ("CEC"), (iv) the California Independent System Operator ("CAISO"), and (v) the Federal Energy Regulatory Commission ("FERC").

Although SCE will seek confidential treatment of any Confidential Information submitted by it to the CPUC, by means of a motion for protective order under Public Utilities Code section 583 and General Order 66-C, or by appropriate application to

or agreement with, the PRG, CAISO and CEC, SCE may disclose Confidential Information under this Paragraph even if no protective order is issued and no confidentiality or non-disclosure agreements are entered into.

Neither SCE nor the Independent Evaluator shall have any liability whatsoever to any party in the event of any unauthorized use or disclosure by a governmental or regulatory agency or entity, including, without limitation, the CPUC and all divisions thereof, CEC, FERC, PRG or CAISO, of any Confidential Information or other information disclosed to any of them by SCE or its representatives.

SCE may also disclose Confidential Information as may be reasonably required to participate in any auction, market or other process pertaining to the allocation of priorities or rights related to the transmission of electrical energy sold or to be sold to SCE under any agreement reached as a result of discussions or negotiations

4. Notwithstanding anything to the contrary set forth herein, the obligations set forth in this Agreement shall not apply to and the term "Confidential Information" shall not include:
  - a. Information which is in the public domain as of the Effective Date or which later comes into the public domain from a source other than from the other Party, its Permitted Disclosee or representatives of its rating agencies;
  - b. Information which SCE or SunPower can demonstrate in writing was already known to SCE or SunPower prior to the Effective Date;
  - c. Information which comes to SCE or SunPower from a bona fide third party source not under an obligation of confidentiality; or
  - d. Information which is independently developed by SCE or SunPower without use of or reference to Confidential Information or information containing Confidential Information.
5. The Parties agree that irreparable damage would occur if this Agreement were not performed in accordance with its terms or were otherwise breached. Accordingly, a Party may be entitled to seek an injunction or injunctions to prevent a breach of this Agreement and to enforce specifically its provisions in any court of competent jurisdiction, in addition to any other remedy to which such Party may be entitled by law or equity.
6. A Party disclosing Confidential Information in hard copy or electronic form shall use best efforts to label it with the following legend:

*"CONFIDENTIAL INFORMATION.  
THE CONTENTS OF THIS DOCUMENT ARE SUBJECT TO  
A NON-DISCLOSURE AGREEMENT"*

A Party's failure to label Confidential Information will not preclude it from later claiming that the information is confidential.

7. The Parties agree not to introduce (in whole or in part) into evidence or otherwise voluntarily disclose in any administrative or judicial proceeding, any Confidential Information, except as required by law, legal compulsion, or with the written consent of the Party providing the Confidential Information or as SCE or SunPower may be required to disclose to duly authorized governmental or regulatory agencies, including the CPUC or any division thereof, in order to demonstrate the reasonableness of its actions.

Notwithstanding the foregoing, either Party may disclose Confidential Information if required to do so in response to a subpoena or other judicial process, provided that the receiving Party, to the extent legally permitted: (a) gives the disclosing Party prompt written notice before making the disclosure; (b) takes reasonable actions and provides reasonable assistance to the disclosing Party to secure, at disclosing Party's sole cost and expense, a protective order seeking confidential treatment of the Confidential Information; and (c) discloses, upon the advice of its legal counsel, only that portion of such Confidential Information as is legally required to be furnished should disclosing Party not obtain such protective order and has not waived compliance with the provisions of this Agreement. Neither Party shall be liable for disclosure of the Confidential Information belonging to the other Party if disclosure was required by subpoena or other judicial process, or by law, rule or regulation.

8. All written Confidential Information supplied by a Party, and all copies or translations thereof made by the Party or Permitted Disclosee who received the Confidential Information, shall, upon written request of the Party who initially provided the Confidential Information, be returned to that Party, destroyed, or held and maintained subject to the terms of this Agreement; provided, however, that electronic copies of or containing Confidential Information that are automatically generated through data backup and/or archiving systems and which are not readily accessible by receiving Party's business personnel (the "electronic copies"), shall not be deemed to violate this Agreement, so long as such Confidential Information is not disclosed or used in violation of the terms of this Agreement. Notwithstanding the foregoing, nothing in this Agreement shall prohibit receiving Party's legal counsel from retaining one (1) copy, including any electronic copy, of any of the Confidential Information as necessary to comply with applicable law or any regulatory recordkeeping requirements applicable to it. Such retained copy shall remain subject to the terms and conditions of this Agreement.
9. Nothing in this Agreement is intended to waive any attorney-client, work-product or other privilege applicable to any statement, document, communication, or other material of a Party or the Parties.
10. Any notice or communication given pursuant to this Agreement shall be in writing and:



- a) Delivered personally, in which case delivery is given upon written acknowledgment of receipt;
- b) Mailed by registered or certified mail; postage prepaid, in which case delivery is given on the earlier of the actual date of delivery, as set forth in the return receipt, or three (3) days from the date posted, or
- c) Delivery by telecopy, in which case delivery is given upon actual receipt of the entire document.

In any of these cases, the writing shall be sent or delivered as follows (subject to change by either Party by notifying the other Party pursuant to this paragraph).

If to SCE:                      Southern California Edison Company  
   2244 Walnut Grove Avenue  
   Rosemead, California 91770  
   Attention: Director, Renewable and Alternative Power  
   Telephone:   (626) 302-1212  
   Facsimile:   (626) 302-1103

If to SunPower:                SunPower Corporation, Systems  
   Attn: Ed Smeloff  
   1414 Harbour Way South  
   Richmond, CA 94804  
   Telephone:   (510) 260-8437  
   Facsimile:   (510) 540-0552

with a copy to:

SunPower Corporation, Systems  
Attn: Jeff Dasovich  
1414 Harbour Way South  
Richmond, CA 94804  
Telephone:   (510) 439-4706  
Facsimile:   (510) 540-0552

and a copy to:

SunPower Corporation  
Attn: General Counsel  
3939 North First Street  
San Jose, CA 95134  
Telephone:   (408) 240-5500  
Facsimile:   (408) 240-5400

- 11. This Agreement shall terminate five (5) years from the Effective Date, or earlier upon the mutual written consent of the Parties or as required by applicable law or decision of the CPUC. Each Party's rights and obligations hereunder with respect to any

Confidential Information shall survive for five (5) years from the date of termination of this Agreement unless otherwise agreed by both Parties in writing.

12. This Agreement shall be interpreted in accordance with the plain meaning of its terms and not strictly for or against any of the Parties hereto.

This Agreement shall be construed as if each Party was its author and each Party hereby adopts the language of this Agreement as if it were its own.

13. Any waiver of the requirements and provisions of this Agreement shall be in writing.

The failure of either Party to enforce at any time any of the provisions of the Agreement or to require at any time performance by the other Party of any of such provisions, shall in no way be construed as a waiver of such provision or a relinquishment of the right thereafter to enforce such provision.

14. This Agreement may not be modified except by a written agreement executed by both Parties.

15. This Agreement shall be interpreted, governed and construed under the laws of the State of California (without giving effect to its conflict of laws provisions that could apply to the law of another jurisdiction) as if executed in and to be wholly performed within the State of California.

16. This Agreement fully expresses the Parties' agreement concerning the subject matter hereof and supersedes any prior agreements or understandings regarding the same subject matter.

17. The signatories hereto represent that they have been duly authorized to enter into this Agreement on behalf of the Party for whom they sign.

18. If any provision hereof is unenforceable or invalid, it shall be given effect to the extent it may be enforceable or valid, and such enforceability or invalidity shall not affect the enforceability or invalidity of any other provision of this Agreement.

*[Remainder of page left blank intentionally.]*

19. This Agreement may be executed in one or more counterparts, each of which will be deemed to be an original of this Agreement and all of which, when taken together, will be deemed to constitute one and the same agreement. The exchange of copies of this Agreement and of signature pages by facsimile transmission or electronic mail shall constitute effective execution and delivery of this Agreement as to the Parties and may be used in lieu of the original Agreement for all purposes. Signatures of the parties transmitted by facsimile or electronic mail shall be deemed to be their original signatures for all purposes.

SUNPOWER CORPORATION, SYSTEMS

a Delaware corporation

By: 

Name: Jeffrey Kasovitch

Title: Managing Director

Date: 10.29.09

SOUTHERN CALIFORNIA EDISON COMPANY,

a California corporation

By: 

Name: Mike Marelli

Title: Director

Date: 10/29/09

*\*\*\* End of EXHIBIT J \*\*\**

**EXHIBIT K**  
*Time of Delivery Periods  
 and  
 Product Payment Allocation Factors*

<u>Time of Delivery Periods (“TOD Periods”)</u>			
<i>TOD Period</i>	<i>Summer Jun 1st – Sep 30<sup>th</sup></i>	<i>Winter Oct 1st – May 31st</i>	<i>Applicable Days</i>
On-Peak	Noon – 6:00 p.m.	Not Applicable.	Weekdays except Holidays.
Mid-Peak	8:00 a.m. – Noon	8:00 a.m. - 9:00 p.m.	Weekdays except Holidays.
	6:00 p.m. – 11:00 p.m.		Weekdays except Holidays.
Off-Peak	11:00 p.m. – 8:00 a.m.	6:00 a.m. – 8:00 a.m.	Weekdays except Holidays.
		9:00 p.m. – Midnight	Weekdays except Holidays.
	Midnight – Midnight	6:00 a.m. – Midnight	Weekends and Holidays
Super-Off-Peak	Not Applicable.	Midnight – 6:00 a.m.	Weekdays, Weekends and Holidays

<u>Product Payment Allocation Factors</u>			
<i>Season</i>	<i>TOD Period</i>	<i>Calculation Method</i>	<i>Product Payment Allocation Factor</i>
Summer	On-Peak	Fixed Value.	3.13
	Mid-Peak	Fixed Value.	1.35
	Off-Peak	Fixed Value.	0.75
Winter	Mid-Peak	Fixed Value.	1.00
	Off-Peak	Fixed Value.	0.83
	Super-Off-Peak	Fixed Value.	0.61

“Holiday” is defined as New Year’s Day, Presidents’ Day, Memorial Day, Independence Day, Labor Day, Veterans Day, Thanksgiving Day, and Christmas Day.

When any Holiday falls on a Sunday, the following Monday will be recognized as a Holiday. No change will be made for Holidays falling on Saturday.

\*\*\* End of EXHIBIT K \*\*\*

*The contents of this document are subject to restrictions on disclosure as set forth herein.*

**EXHIBIT L***Procedure for Partial or Full Return of Development Security*1. Seller's Request for Development Security Refund.

Seller shall provide Notice to SCE of its request for a refund of Development Security and Milestone Amount (if any) based upon either of the following:

- (a) Termination pursuant to Sections 2.04(a) or 5.05; or
- (b) Seller has completed installation of the Inverter Block Units and all of the equipment and devices (consistent with the Generating Facility and Site Descriptions set forth in Exhibit B-1) necessary for the Generating Facility to Operate and deliver energy to the Delivery Point in accordance with this Agreement.

Any dispute relating to a request for a refund of Development Security and Milestone Amount (if any) will be resolved in accordance with Item 4 below.

2. Full Return of Development Security for Termination of Agreement.

If SCE does not dispute Seller's Notice of request for a refund pursuant to Item 1(a) above, SCE shall return the Development Security and Milestone Amount (if any) to Seller, or Letter of Credit to the issuing bank, within ten (10) Business Days after such Notice.

3. Full or Partial Return of Development Security for Demonstrating Contract Capacity.

- (a) Determination of the Demonstrated Contract Capacity.
  - (i) Unless SCE provides timely Notice to Seller that additional days are required to substantiate data or that SCE disputes the request for a refund, SCE shall within thirty (30) days after Seller's Notice of request for a refund pursuant to Item 1(b) above complete a site visit in order to:
    - a. Verify that the Generating Facility was developed in accordance with the Generating Facility Capacity and Site Description set forth in Exhibit B-1;
    - b. Determine the Demonstrated Contract Capacity; and
    - c. Determine the Installed DC Rating.
  - (ii) The "Demonstrated Contract Capacity" shall be the lesser of:
    - a. The Generating Facility Capacity as verified by the site visit; or

*The contents of this document are subject to restrictions on disclosure as set forth herein.*

- b. Contract Capacity.
  - (iii) Seller shall promptly submit a revised Exhibit B-1 to reflect such verified Generating Facility Capacity.
- (b) If the Demonstrated Contract Capacity as determined in Item 3(a) above is greater than or equal to the Contract Capacity, *then* Seller will qualify to receive a full return of the Development Security.
- (c) If the Demonstrated Contract Capacity as determined in Item 3(a) above is less than the Contract Capacity, *then* Seller will qualify to receive a return of only a portion of the Development Security based upon the level of the Demonstrated Contract Capacity.
- (d) Upon determination of the Demonstrated Contract Capacity, SCE shall:
  - (i) Calculate the amount of Development Security refund due Seller pursuant to Sections 3.06(e) and 3.06(f) based upon the information in Item 3(a) of this Exhibit L,
  - (ii) Provide Notice to Seller of the amount of Development Security being returned pursuant to Item 3(d) of this Exhibit L, the amount of Development Security forfeited, as applicable, and the reason(s) that a forfeiture of all or part of the Development Security is appropriate.
  - (iii) Return any Development Security due Seller if such Development Security were posted in the form of cash.
  - (iv) Return the Letter of Credit to the issuing bank if the total amount of the posted Development Security is due Seller. If Seller is only entitled to a partial return of the Development Security SCE shall submit a drawing certificate on the Letter of Credit for the amount of Development Security forfeited by Seller, after which SCE shall release the remaining balance of the Letter of Credit.

To the extent Seller has posted Development Security in accordance with Section 3.06 and Seller is entitled to a partial return of the Development Security, SCE shall return only a portion of the Development Security based upon the level of the Demonstrated Contract Capacity.

- (e) If the Demonstrated Contract Capacity is greater than zero (0) MW, SCE shall return the Milestone Amount to Seller concurrently with any Development Security returned to Seller pursuant to Item 3(d) of this Exhibit L.
4. Disputes.
- (a) The Parties shall negotiate in good faith to resolve any disputes with respect to the refund of Development Security and the Milestone Amount, (if any) and shall, as part of such good faith negotiations, promptly provide information or

data relevant to the dispute as each Party may possess which is requested by the other Party.

- (b) If the Parties are unable to resolve a dispute regarding the refund of Development Security or the Milestone Amount (if any) within thirty (30) days after the sending of a Notice of dispute by SCE, either Party may submit the dispute to mediation and arbitration as provided in Article Twelve.

---

\*\*\* End of EXHIBIT L \*\*\*



## **EXHIBIT M**

### *Seller's Estimate of Lost Output*

Lost Output, as used in Section 3.23, shall be estimated by Seller in accordance with the procedures described in this Exhibit M.

Seller shall (1) collect the measurement data and perform the engineering calculations specified below in one (1) or more Microsoft Excel Workbooks (the "Lost Output Workbook") provided in a form and naming convention approved by SCE and (2) electronically send the Lost Output Workbook to an address provided by SCE.

SCE shall have the right to verify all data by inspecting measurement instruments and reviewing Generating Facility Operating records.

Seller shall update the Lost Output Workbook each month and shall include the latest revision of the Lost Output Workbook with its monthly Lost Output Report.

#### 1. Log of Lost Output Events.

The log of Lost Output events must be created on a single, dedicated worksheet that is arranged with:

- (a) One (1) column for a Lost Output event number;
- (b) One (1) column for the Term Year number;
- (c) One (1) column for the start date;
- (d) One (1) column for the start time;
- (e) One (1) column for the end date;
- (f) One (1) column for the end time;
- (g) One (1) column for the duration;
- (h) One (1) column for the cause;
- (i) One (1) column for the total of Metered Amounts during all of the Settlement Intervals of the Lost Output event, recorded in Seller's Settlement Interval Estimate of Lost Output set forth in Item 4(i) in this Exhibit M;
- (j) One (1) column for the total of the Lost Output *preliminary* results during all of the Settlement Intervals of the Lost Output event, calculated in Seller's Settlement Interval Estimate of Lost Output set forth in Item 4(m) in this Exhibit M;
- (k) One (1) column for the total of the Lost Output *final* results during all of the Settlement Intervals of the Lost Output event, calculated in Settlement Interval Estimate of Lost Output set forth in Item 4(n) in this Exhibit M; and
- (l) One (1) row for each Lost Output Event.

*The contents of this document are subject to restrictions on disclosure as set forth herein.*

## 2. Generating Facility Energy Yield Curve.

Seller shall create a Generating Facility Energy Yield Curve table on a single dedicated worksheet that is arranged with:

- (a) One (1) column for an item number;
- (b) One (1) column for the plane of array insolation;
- (c) One (1) column for the manufacturer's estimate of the electric energy that can be produced by a single Inverter Block Unit at each increment of plane of array insolation;
- (d) Multiple columns for a energy yield curve which estimates the electric energy that could be produced by the entire Generating Facility at each plane of array insolation increment and number of in service Inverter Block Units calculated by:
  - (i) *Multiplying* the Inverter Block Unit manufacturer's estimate of the electric energy that will be produced by a single unit, set forth in Item 2(c);
  - (ii) *Times* the total number of in service Inverter Block Units; and then
  - (iii) *Adjusting* the results for the estimated impacts of one (1) Inverter Block Unit on another and for electric losses within the Generating Facility;
- (e) Multiple columns for each Term Year energy yield curve which includes a simple average of all Metered Amount data points, set forth in Item 3(f), at each plane of array insolation increment and number of in service Inverter Block Units; and
- (f) One (1) row for each watt-hour per square meter of plane of array solar insolation.

Seller shall also create a single chart which plots all of energy yield curves set forth in Item 2(d) and Item 2(e) of this Exhibit M on the Generating Facility Energy Yield Curve worksheet.

## 3. Plane of Array Insolation Data Collection.

Seller shall record average Settlement Interval plane of array insolation, in watt-hours per square meter, and Metered Amounts in the Settlement Interval in the Lost Output Workbook on individual Term Year worksheets.

Each Term Year worksheet must be arranged with:

- (a) One (1) column for an item number;
- (b) One (1) column for the date;
- (c) One (1) column for the beginning time;

- (d) One (1) column for the weekday;
  - (e) One (1) column for each recorded plane of array insolation measurement;
  - (f) One (1) column for each Metered Amounts quantity;
  - (g) One (1) column for a forecast of Metered Amounts determined by:
    - (i) *Multiplying* the recorded plane of array insolation measurement set forth in Item 3(e) of this Exhibit M;
    - (ii) *Times* the appropriate value in the Generating Facility Energy Yield Curve, set forth in Item 2(e) of this Exhibit M, for the first Term Year;
  - (h) One (1) column for the number of Inverter Blocks in service; and
  - (i) One (1) row for each Settlement Interval period.
4. Detailed Estimate of Lost Output.

Seller's detailed estimate of the Lost Output amounts during the Term shall be presented on a single worksheet organized as follows:

- (a) One column for an item number;
- (b) One (1) column for the Lost Output event number;
- (c) One (1) column for the state date;
- (d) One (1) column for the start time;
- (e) One (1) column for the end date;
- (f) One (1) column for the end time;
- (g) One (1) column for the weekday;
- (h) One (1) column for the plane of array insolation;
- (i) One (1) column for Metered Amounts;
- (j) One (1) column for the number of Inverter Block Units in service.
- (k) One (1) column for a *preliminary* estimate of the Metered Amounts that would have been produced by the Generating Facility, but for the Lost Output event:
  - (i) *Multiplying* the plane of array insolation:
  - (ii) *Times* the appropriate initial energy yield curve as follows:
    1. For the first eleven (11) months of the first Term Year the appropriate initial energy yield curve must be the energy yield curve set forth in Item 2(d) of this Exhibit M;
    2. For the first eleven (11) months of any Term Year, other than the first Term Year, the appropriate initial energy yield curve

*The contents of this document are subject to restrictions on disclosure as set forth herein.*

must be the energy yield curve set forth in Item 2(e) of this Exhibit M for the previous Term Year;

- (l) One (1) column for a *final* estimate of the Metered Amounts that would have been produced by the Generating facility, but for the Lost Output event calculated by:
    - (i) *Multiplying* the plane of array insolation;
    - (ii) *Times* the *final* energy yield curve from Item 2(e) of this Exhibit M for the Term Year being calculated;
  - (m) One (1) column for the *preliminary* estimate of Lost Output calculated by:
    - (i) *Subtracting* the actual Metered Amount quantities set forth in Item 4(i) of this Exhibit M;
    - (ii) *From* the preliminary estimate of the Metered Amounts that would have been produced by the Generating Facility, but for the Lost Output event, calculated in Item 4(j); and
  - (n) One (1) column for the *final* estimate of Lost Output calculated by:
    - (i) *Subtracting* the actual Metered Amount quantities set forth in Item 4(i) of this Exhibit M;
    - (ii) *From* the estimate of Metered Amounts that would have been produced by the Generating Facility, but for the Lost Output event, calculated in Item 4(k) of this Exhibit M; and
  - (o) One (1) row for each Settlement Interval.
5. Generating Facility Performance Factor Calculation.

Seller shall calculate a Generating Facility performance factor value for each calendar month and each Term Year on a dedicated worksheet organized with three tables.

- (a) The first table must contain the monthly Metered Amount totals and must consist of:
  - (i) One (1) column for the month number;
  - (ii) One (1) column for the month name;
  - (iii) One (1) column for the year number;
  - (iv) One (1) column for the monthly Metered Amount totals for each Term Year from the plane of array insolation data collection worksheet column set forth in Item 3(f) of this Exhibit M; and
  - (v) One (1) row for each month;
- (b) The second table must contain the monthly totals of forecasted Metered Amount and must consist of:

*The contents of this document are subject to restrictions on disclosure as set forth herein.*

- (i) One (1) column for the month number;
  - (ii) One (1) column for the month name;
  - (iii) One (1) column for the year number;
  - (iv) One (1) column for the monthly totals of forecasted Metered Amount for each Term Year from the plane of array insolation data collection worksheet column set forth in Item 3(g) of this Exhibit M; and
  - (v) One (1) row for each month; and
- (c) The third table must contain monthly performance factors and must consist of:
- (i) One (1) column for the month number;
  - (ii) One (1) column for the month name;
  - (iii) One (1) column for the year number;
  - (iv) One (1) column for a monthly Generating Facility performance factor result and a Term Year Generating Facility performance factor results calculated by:
    - 1. *Dividing* the appropriate value in the first table;
    - 2. *By* the appropriate value in the second table;
  - (v) One (1) row for each month; and
  - (vi) One (1) row for the Term Year Generating Facility performance factor results.
6. Periodic Review of Lost Output Calculation.
- At least once per Term Year, SCE shall review the variation in the Lost Output preliminary and final results to determine if other variables, including temperature, precipitation, solar altitude or azimuth angles or other measured parameters per Exhibit T, should be incorporated into the Lost Output calculations, and Seller shall put in all reasonable changes requested by SCE.
7. Assignment of Lost Output Estimate to an Independent Consultant.
- The Parties can by mutual agreement elect to have the estimate of Lost Output prepared by an independent consultant.

---

\*\*\* End of EXHIBIT M \*\*\*

**EXHIBIT N**  
*Form of Letter of Credit*

IRREVOCABLE NONTRANSFERABLE STANDBY

LETTER OF CREDIT

Reference Number:

Transaction Date:

BENEFICIARY:

Southern California Edison Company

2244 Walnut Grove Avenue

Risk Control GO#1, Quad 1D

Rosemead, CA 91770

Ladies and Gentlemen:

\_\_\_\_\_ (the "Bank") hereby establishes this Irrevocable Nontransferable Standby Letter of Credit ("Letter of Credit") in favor of Southern California Edison Company, a California corporation (the "Beneficiary"), for the account of \_\_\_\_\_, a \_\_\_\_\_ corporation, also known as RAP ID# \_\_\_\_ (the "Applicant"), for the amount of XXX AND XX/100 Dollars (\$\_\_\_\_\_) (the "Available Amount"), effective immediately and expiring at 5:00 p.m., California time, on \_\_\_\_\_ (the "Expiration Date").

This Letter of Credit shall be of no further force or effect upon the close of business on the Expiration Day or, if such day is not a Business Day (as hereinafter defined), on the next Business Day.

For the purposes hereof, "Business Day" shall mean any day on which commercial banks are not authorized or required to close in Los Angeles, California.

*The contents of this document are subject to restrictions on disclosure as set forth herein.*

Subject to the terms and conditions herein, funds under this Letter of Credit are available to Beneficiary by presentation in compliance on or before 5:00 p.m. California time, on or before the Expiration Date of the following:

1. The original of this Letter of Credit and all amendments (or photocopy of the original for partial drawings); and
2. The Drawing Certificate issued in the form of Attachment A attached hereto and which forms an integral part hereof, duly completed and purportedly bearing the signature of an authorized representative of the Beneficiary.

Notwithstanding the foregoing, any drawing hereunder may be requested by transmitting the requisite documents as described above to the Bank by facsimile at \_\_\_\_\_ or such other number as specified from time-to-time by the Bank.

The facsimile transmittal shall be deemed delivered when received. Drawings made by facsimile transmittal are deemed to be the operative instrument without the need of originally signed documents.

Partial drawing of funds shall be permitted under this Letter of Credit, and this Letter of Credit shall remain in full force and effect with respect to any continuing balance; *provided*, the Available Amount shall be reduced by the amount of each such drawing.

This Letter of Credit is not transferable or assignable. Any purported transfer or assignment shall be void and of no force or effect.

Banking charges shall be the sole responsibility of the Applicant.

This Letter of Credit sets forth in full our obligations and such obligations shall not in any way be modified, amended, amplified or limited by reference to any documents, instruments or agreements referred to herein, except only the attachment referred to herein; and any such reference shall not be deemed to incorporate by reference any document, instrument or agreement except for such attachment.

The Bank engages with the Beneficiary that Beneficiary's drafts drawn under and in compliance with the terms of this Letter of Credit will be duly honored if presented to the Bank on or before the Expiration Date.

Except so far as otherwise stated, this Letter of Credit is subject to the International Standby Practices ISP98 (also known as ICC Publication No. 590), or revision currently in effect (the "ISP"). As to matters not covered by the ISP, the laws of the State of California, without regard to the principles of conflicts of laws thereunder, shall govern all matters with respect to this Letter of Credit.

AUTHORIZED SIGNATURE for Issuer

*The contents of this document are subject to restrictions on disclosure as set forth herein.*

\_\_\_\_\_

(Name)

Title: \_\_\_\_\_



**ATTACHMENT A**  
*Drawing Certificate*

TO *[ISSUING BANK NAME]*

IRREVOCABLE NON-TRANSFERABLE STANDBY LETTER OF CREDIT

No. \_\_\_\_\_

DRAWING CERTIFICATE

Bank

Bank Address

Subject: Irrevocable Non-transferable Standby Letter of Credit

Reference Number: \_\_\_\_\_

The undersigned \_\_\_\_\_, an authorized representative of Southern California Edison Company (the “Beneficiary”), hereby certifies to *[Issuing Bank Name]* (the “Bank”), and \_\_\_\_\_ (the “Applicant”), with reference to Irrevocable Nontransferable Standby Letter of Credit No. { \_\_\_\_\_ }, dated \_\_\_\_\_, (the “Letter of Credit”), issued by the Bank in favor of the Beneficiary, as follows as of the date hereof:

- 1. The Beneficiary is entitled to draw under the Letter of Credit an amount equal to \$ \_\_\_\_\_, for the following reason(s) [check applicable provision]:
  - [ ] A. An Event of Default, as defined in that certain Renewable Power Purchase and Sale Agreement between Applicant and Beneficiary, dated as of *[Date of Execution]* (the “Agreement”), with respect to the Applicant has occurred and is continuing.
  - [ ] B. An Early Termination Date (as defined in the Agreement) has occurred or been designated as a result of an Event of Default (as defined in the Agreement) with respect to the Applicant for which there exist any unsatisfied payment obligations.
  - [ ] C. The Letter of Credit will expire in fewer than twenty (20) Local Business Days (as defined in the Agreement) from the date hereof, and Applicant has

*The contents of this document are subject to restrictions on disclosure as set forth herein.*

not provided Beneficiary alternative Performance Assurance or Development Security (as defined in the Agreement) acceptable to Beneficiary.

- [ ]D. The Applicant or the Bank has heretofore provided written notice to the Beneficiary of the Applicant's or the Bank's intent not to renew the Letter of Credit following the present Expiration Date thereof ("Notice of Non-Renewal"), and Applicant has failed to provide the Beneficiary with a replacement letter of credit satisfactory to Beneficiary in its sole discretion within thirty (30) days following the date of the Notice of Non-Renewal.
  - [ ]E. The Beneficiary has not been paid any or all of the Applicant's payment obligations now due and payable under the Agreement.
  - [ ]F. The Beneficiary is entitled to retain the entire Development Security: (i) as a result of Applicant's failure to achieve Commercial Operation of the full Contract Capacity by the Commercial Operation Deadline or any extended Commercial Operation Deadline as provided in the Agreement; (ii) because Commercial Operation Date has not occurred on or before the Commercial Operation Deadline or for any of the reasons set forth in Section 3.06(d) of the Agreement; or (iii) because the Agreement has been terminated due to an Event of Default by Applicant before the Commercial Operation Deadline.
  - [ ]G. The Beneficiary is entitled to retain a portion of the Development Security equal to the product of Thirty Dollars (\$30) per kilowatt times the Unincluded Capacity in kilowatts as a result of Applicant demonstrating only a portion of the Contract Capacity.
  - [ ]H. The Beneficiary is entitled to retain a portion of the Development Security equal to the product of Fifteen Dollars (\$15) per kilowatt times the Capacity Permit Reduction Quantity as a result of Applicant's reduction of Contract Capacity.
  - [ ]I. The Beneficiary is entitled to retain the Milestone Amount as a result of Applicant's failure to meet Milestone Schedule deadline in accordance with Section 3.06(d)(ii).
2. Based upon the foregoing, the Beneficiary hereby makes demand under the Letter of Credit for payment of U.S. DOLLARS AND \_\_\_\_/100ths (U.S.\$ \_\_\_\_\_), which amount does not exceed (i) the amount set forth in paragraph 1 above, and (ii) the Available Amount under the Letter of Credit as of the date hereof.
3. Funds paid pursuant to the provisions of the Letter of Credit shall be wire transferred to the Beneficiary in accordance with the following instructions:

---

*The contents of this document are subject to restrictions on disclosure as set forth herein.*

\_\_\_\_\_  
\_\_\_\_\_

Unless otherwise provided herein, capitalized terms which are used and not defined herein shall have the meaning given each such term in the Letter of Credit.

IN WITNESS WHEREOF, this Certificate has been duly executed and delivered on behalf of the Beneficiary by its authorized representative as of this \_\_\_\_ day of \_\_\_\_\_, \_\_\_\_\_.

Beneficiary: SOUTHERN CALIFORNIA EDISON COMPANY

By:

Name:

Title:

\*\*\* *End of EXHIBIT N* \*\*\*

**EXHIBIT O**  
*Product Price*

1. The Product Price will be as follows:

<u>Term Year</u>	<u>Product Price, in \$/MWh</u>
Startup Period	61.16
1	81.55
2	83.59
3	85.68
4	87.82
5	90.02
6	92.27
7	94.57
8	96.94
9	99.36
10	101.84
11	104.39
12	107.00
13	109.68
14	112.42
15	115.23
16	118.11
17	121.06
18	124.09
19	127.19
20	130.37
Curtailed Return Term, if any	86.92

---

\*\*\* End of EXHIBIT O \*\*\*

*The contents of this document are subject to restrictions on disclosure as set forth herein.*

**EXHIBIT P**

*[Intentionally Omitted.]*

---

*\*\*\* End of EXHIBIT P \*\*\**

*The contents of this document are subject to restrictions on disclosure as set forth herein.*

**EXHIBIT Q***SCE Penalties and CAISO Sanctions*

Seller is liable for SCE Penalties and CAISO Sanctions under the circumstances described in this Exhibit Q.

1. Determining Seller's Liability for SCE Penalties.

- (a) If in any hour of any month throughout the Delivery Term Seller fails to comply with its Forecasting requirements under Exhibit D of this Agreement, and the sum of Energy Deviations for each of the six Settlement Intervals in that hour exceed the Performance Tolerance Band described in Paragraph 2 of this Exhibit, then, subject to Item 1.(b) and Item 1.(c) below, Seller is liable for an SCE Penalty equal to one hundred fifty percent (150%) of the Product Price in Section 1.07 for each kWh (i.e., \$/MWh/1000) of electric Energy Deviation in that hour.
- (b) The SCE Penalty will be waived the first hour of the first calendar day (and any subsequent hours of such day) in each month in which Seller fails to comply with its Forecasting requirements under Exhibit D.
- (c) The SCE Penalty will be assessed during any hour of any calendar day thereafter in that month in which Seller fails to meet these Forecasting requirements.

2. Performance Tolerance Band.

The "Performance Tolerance Band," in kWh, is equal to:

- (a) Three percent (3%) times
- (b) Contract Capacity times
- (c) One (1) hour, i.e., the interval of time for monitoring Forecasting requirements.

3. Seller's Liability for CAISO Sanctions.

Seller must reimburse SCE for all CAISO Sanctions incurred by SCE as a result of Seller's failure to adhere to its obligations under the CAISO Tariff or any CAISO directive, as such directive may be communicated to Seller by SCE, or as set forth in Section 4.01(c).

4. Billing and Documentation of CAISO Costs and CAISO Sanctions.
- (a) The CAISO Sanctions will be available for billing approximately one hundred twenty (120) days following the last day of the calendar month in which the event giving rise to the sanction occurs, or thirty (30) days after the CAISO final settlement data is available to SCE, whichever is sooner.
  - (b) SCE shall provide to Seller the applicable back-up data used for validating CAISO Sanctions.

---

\*\*\* End of EXHIBIT Q \*\*\*

**EXHIBIT R**

*[Intentionally Omitted.]*

---

*\*\*\* End of EXHIBIT R \*\*\**

*The contents of this document are subject to restrictions on disclosure as set forth herein.*



## **EXHIBIT S**

### *Actual Availability Report*

Pursuant to Section 3.24, Seller shall prepare an Actual Availability Report in accordance with the procedures described in this Exhibit S.

1. Availability Workbook.

Seller shall:

- (a) Collect the measurement data, listed in Item 2 below, in one (1) or more Microsoft Excel Workbooks (the “Availability Workbook”) provided in a form and naming convention approved by SCE; and
- (b) Electronically send the Availability Workbook to an address provided by SCE.

The Actual Availability Report must reflect the sum of the Settlement Interval Actual Available Capacity of all Inverter Block Units and associated Current Inverters generators as measured by Seller’s SCADA equipment.

2. Log of Availability.

The Availability Workbook must be created on a single, dedicated worksheet and shall be in the form of Attachment 1 to this Exhibit S.

The data presented in the Availability Workbook must not reflect any electric energy losses between the CAISO Approved Meter or Check Meter and the Delivery Point.

**ATTACHMENT 1**

*Actual Availability Report*

*(Form of Microsoft Excel File Attachment to E-mail Notice)*



---

*\*\*\* End of EXHIBIT S \*\*\**

*The contents of this document are subject to restrictions on disclosure as set forth herein.*

---

**EXHIBIT T***Meteorological Station Specifications*

Pursuant to Section 3.08(f), Seller shall install and maintain a minimum of one (1) stand-alone meteorological equipment station for each one (1) square mile, or portion thereof, of the Site. Each station shall be equipped with instruments and equipment that meet or exceed those specifications set forth in the CAISO's PIRP protocol and are compatible with the requirements of SCE. SCE and Seller acknowledge that SCE may update this Exhibit T from time to time in order to accommodate industry standards, the CAISO PIRP protocol and the needs of SCE following industry standards.

SCE and Seller shall develop the technical specifications for meteorological stations, which will meet these basic requirements.

Seller shall be required to maintain the meteorological station in accordance with Prudent Electrical Practices. In addition, any solar irradiance sensor must be cleaned at a minimum weekly but in any case, after any storm events.

1. Equipment Stations.

- (a) The equipment stations shall be comprised of the following:
  - (i) One (1) heated wind sensor;
  - (ii) One (1) air temperature sensor;
  - (iii) One (1) relative humidity sensor;
  - (iv) One (1) barometric pressure sensor (with DCP sensor);
  - (v) One (1) total global irradiation sensor for each collector plane orientation in the Site. The sensor(s) are oriented at the same inclination and aspect as the collector plane(s);
  - (vi) One (1) total global radiation sensor horizontal to the ground plane (only 1 such sensor shall be required under this Agreement); and
  - (vii) One (1) diffuse radiation sensor (only 1 such sensor shall be required under this Agreement).
- (b) In addition, Seller shall report:
  - (i) Solar altitude angle;
  - (ii) Solar azimuth angle; and
  - (iii) Precipitation.
- (c) All sensors shall be set at a height location representing the height from ground level of the solar collection point, for example, two (2) meters above ground level.

*The contents of this document are subject to restrictions on disclosure as set forth herein.*

2. Attributes of Equipment Station Locations.

The equipment station location(s) should be unencumbered by any shadow or equipment. The equipment station tower is to be placed in front of the solar collectors on the southern side of the Site. In addition, if the project uses satellite communication transmitter then the station's satellite communication transmitter requires an unencumbered south-by-south west view of the sky for antenna placement.

3. Communication.

Seller shall communicate meteorological data to SCE via a system consistent with SCE's employed methods at the time of installation. The equipment installed will need to be approved by SCE, which approval shall not be unreasonably withheld.

4. Minimum Equipment Requirements.

As of the Effective Date, SCE requires equipment with quality levels, compatibility and functional specifications that meet or exceed those of the equipment set forth below in this Item 4. Any equipment different from that listed below must have the approval of SCE before installation at the Site, which approval shall not be unreasonably withheld.

(a) MAWS301 AWS System.

(i) MAWS301 Basic Assembly for MAWS301 Automatic Weather Station, including following modules and functions:

- QML201 AWS Logger with 1.7 MB Flash memory for data logging
- QBR101B Battery regulator
- ENC542PLM Equipment enclosure with backup battery mounting accessories and internal wiring
- Bottom plate with signal connectors for sensors and peripheral equipment
- MAWS LIZARD Set-up software
- MAWS Terminal software

(ii) ENC542SHIELD Radiation Shield for MAWS301 enclosure

(iii) QMZ101 Terminal/maintenance cable for MAWS

(iv) QMBATT12 Back-up battery - 12 Ah/12V, installed in MAWS enclosure, includes wiring

(b) Sensors.

(i) QMT110 Air temperature sensor with 10 m cable and connector

- DTR502P22 Radiation shield for QMT110 (air temp sensor) including mounting accessories to a pole/mast (60-100 mm)
  - (ii) QMT103 Air temperature sensor with 5-m cable and connector
    - 212417 Extension cables, 25m, shielded, 5-pin F-M connector for QMT103 sensor
    - DTR502P22 Radiation shield for QMT103 (air temp sensor) including mounting accessories to a pole/mast (60-100 mm)
  - (iii) PMT16A Barometric pressure sensor installed within the MAWS301 enclosure
  - (iv) M301-WS425STDH Heated Ultrasonic Wind Sensor with RS485 & power output cable, sensor mounting on 60 mm diameter pole/mast and 36 VDC power supply
  - (v) HMT 100 humidity and temperature sensor
  - (vi) Model RSR-2, Rotating Shadowband Radiometer System from Irradiance Inc. for site global horizontal and diffuse irradiance
  - (vii) Kipp and Zonen Model CMP-11, thermopile pyranometer mounted in the plane of the solar array for each solar array orientation
- (c) Powering.  
MCP150-M3-115 Mains (AC) power supply, installed in enclosure (ENC542PLM), including wiring and surge arrestors for 115 VAC
- (d) Communication.
- (i) DSI485ASET48-M3 Isolated RS-485 module - 2 wire connection, including extra surge arrestors for both lines, installed in MAWS enclosure communications from logger to WS425 sensors
  - (ii) DME421-M3 Ethernet interface serial port to VSAT transmitter. Module mounted within MAWS enclosure
  - (iii) VSAT Hardware, VSAT transmitter, cables with connectors, testing of each site, antenna positioners, mounting hardware. Installation at each site should include program fee for VSAT module
- (e) Install Accessories.
- (i) APPK-60SET Mast mounting for MAWS enclosure on a 50-60 mm diameter pole/mast/tower
  - (ii) QSA124PT Surge Arrestor for QMT103/110 Temp sensor lines (4-wire)
  - (iii) #010411 Shielded RS485 cabling from MAWS301 to WS425STDH - 10m cables

- (iv) QSA224DC Surge Arrestor for RS485 lines, wind sensors at 10m
- 

\*\*\* End of EXHIBIT T \*\*\*



**EXHIBIT U**  
*Notice of SCE's Rights*

**RECORDING REQUESTED BY**

**AND WHEN RECORDED MAIL TO:**

Southern California Edison

2244 Walnut Grove Avenue  
Rosemead, California 91770

Attention: SCE Law Department, Manager of  
Power Procurement Section

APN: \_\_\_\_\_

*(Space Above for Recorder's Use Only)*

**NOTICE OF SCE's RIGHTS**

**NOTICE IS HEREBY GIVEN THAT SOUTHERN CALIFORNIA EDISON COMPANY**, a California corporation ("SCE"), and *[Seller's Name]*, a *[Seller's business registration]* ("Seller"), have entered into that Renewable Power Purchase and Sale Agreement dated as of \_\_\_\_\_ (as amended, supplemented and revised from time to time, the "Agreement"). Pursuant to the Agreement, SCE has the right to purchase all electric energy, Green Attributes, Capacity Attributes and Resource Adequacy Benefits (as such terms are defined in the Agreement) associated with or attributable to any generating facilities located or to be located on that certain real property (the "Property") more particularly described on Exhibit A attached hereto and incorporated herein by the reference.

*The contents of this document are subject to restrictions on disclosure as set forth herein.*

SCE's rights shall terminate as set forth in the Agreement, but not later than \_\_\_\_\_. This Notice shall terminate automatically on \_\_\_\_\_, unless earlier terminated by SCE by recording a notice of termination.

Reference is made to the Agreement for the terms and conditions of SCE's rights. In the event of a conflict between the terms of this Notice and the terms of the Agreement, the terms of the Agreement shall control.

*[Signatures are on the following page]*

**SOLAR STAR CALIFORNIA XX,  
LLC,**

a Delaware limited liability company.

By: \_\_\_\_\_  
Its:

Date: \_\_\_\_\_

By: \_\_\_\_\_  
Its:

Date: \_\_\_\_\_

**SOUTHERN CALIFORNIA EDISON  
COMPANY,**

a California corporation.

By: \_\_\_\_\_

*Vice President of  
Renewable and Alternative Power*

Date: \_\_\_\_\_

**EXHIBIT A**

[Legal Description of Property]

ACKNOWLEDGMENT

STATE OF CALIFORNIA )

)

COUNTY OF LOS ANGELES )

On \_\_\_\_\_ 20\_\_\_\_, before me, \_\_\_\_\_, Notary Public, personally appeared \_\_\_\_\_, who proved to me on the basis of satisfactory evidence to be the person(s) whose name(s) is/are subscribed to the within instrument and acknowledged to me that he/she/they executed the same in his/her/their authorized capacity(ies), and that by his/her/their signature(s) on the instrument, the person(s), or the entity upon behalf of which the person(s) acted, executed the instrument.

I certify under PENALTY OF PERJURY under the laws of the State of California that the foregoing paragraph is true and correct.

WITNESS my hand and official seal.

\_\_\_\_\_

[SEAL]

ACKNOWLEDGMENT

STATE OF CALIFORNIA            )

)

COUNTY OF LOS ANGELES        )

On \_\_\_\_\_ 20\_\_\_\_, before me,  
\_\_\_\_\_, Notary Public,  
personally appeared \_\_\_\_\_, who  
proved to me on the basis of satisfactory evidence to be the person(s) whose name(s)  
is/are subscribed to the within instrument and acknowledged to me that he/she/they  
executed the same in his/her/their authorized capacity(ies), and that by his/her/their  
signature(s) on the instrument, the person(s), or the entity upon behalf of which the  
person(s) acted, executed the instrument.

I certify under PENALTY OF PERJURY under the laws of the State of California that  
the foregoing paragraph is true and correct.

WITNESS my hand and official seal.

\_\_\_\_\_

[SEAL]

*\*\*\* End of EXHIBIT U \*\*\**