

POWER PURCHASE AGREEMENT

Between

SAN DIEGO GAS & ELECTRIC COMPANY
(as "Buyer")

and

NRG SOLAR BORREGO I LLC
(as "Seller")

POWER PURCHASE AGREEMENT

TABLE OF CONTENTS

COVER SHEET.....	1
GENERAL TERMS AND CONDITIONS	1
ARTICLE ONE: GENERAL DEFINITIONS.....	1
1.1 General.....	1
1.2 Interpretation.....	15
ARTICLE TWO: EFFECTIVENESS OF AGREEMENT; CONDITIONS PRECEDENT	16
2.1 Effectiveness of Agreement Prior to CP Satisfaction Date.	16
2.2 Obligations of the Parties.....	17
2.3 Conditions Precedent.	17
2.4 Failure to Meet All Conditions Precedent.	18
2.5 Effectiveness of Agreement on and after CP Satisfaction Date.	19
ARTICLE THREE: OBLIGATIONS AND DELIVERIES	20
3.1 Transaction.....	20
3.2 Transmission.	25
3.3 Scheduling.....	26
3.4 Dispatch Down/Curtailment.	29
3.5 Standards of Care.	29
3.6 Metering.....	30
3.7 Outage Notification.....	31
3.8 Operations Logs and Access Rights.	32
3.9 New Generation Facility.	33
3.10 Operating Procedures.....	36
ARTICLE FOUR: COMPENSATION; MONTHLY PAYMENTS; COMPLIANCE EXPENDITURE CAPS	36
4.1 Energy Payment.....	36
4.2 Imbalance Energy.	37
4.4 Test Energy	37
4.5 Expenditures Exceeding Compliance Expenditure Cap.	37
ARTICLE FIVE: EVENTS OF DEFAULT; FORCE MAJEURE.....	38
5.1 Events of Default.	38
5.2 Remedies; Declaration of Early Termination Date.....	40
5.3 Termination Payment.....	41
5.4 Notice of Payment of Termination Payment.	41
5.5 Disputes With Respect to Termination Payment.	41
5.6 Rights And Remedies Are Cumulative.....	42
5.7 Mitigation.....	42

5.8	Force Majeure	42
ARTICLE SIX: PAYMENT		42
6.1	Billing and Payment.....	42
6.2	Disputes and Adjustments of Invoices.....	43
6.3	Netting of Payments.....	43
ARTICLE SEVEN: LIMITATIONS.....		43
7.1	Limitation of Remedies, Liability and Damages.....	43
ARTICLE EIGHT: CREDIT AND COLLATERAL REQUIREMENTS		44
8.1	Buyer Financial Information.....	44
8.2	Seller Financial Information.....	44
8.3	Grant of Security Interest/Remedies.....	45
8.4	Performance Assurance.....	45
8.5	Interest on Cash.....	47
8.6	Costs of Letter of Credit.....	47
ARTICLE NINE: GOVERNMENTAL CHARGES		47
9.1	Cooperation.....	47
9.2	Governmental Charges.....	47
ARTICLE TEN: REPRESENTATIONS AND WARRANTIES; COVENANTS		47
10.1	General Representations and Warranties.....	47
10.2	Seller Representations and Warranties.....	48
10.3	Covenants.....	49
ARTICLE ELEVEN: TITLE, RISK OF LOSS, INDEMNITIES		50
11.1	Title and Risk of Loss.....	50
11.2	Indemnities.....	50
ARTICLE TWELVE: DISPUTE RESOLUTION.....		51
12.1	Intent of the Parties.....	51
12.2	Management Negotiations.....	51
12.3	Arbitration.....	52
ARTICLE THIRTEEN: MISCELLANEOUS.....		53
13.1	Confidentiality.....	53
13.2	Assignment.....	54
13.3	Audit.....	54
13.4	Sarbanes-Oxley and Securities and Exchange Commission Requirements.....	55
13.5	Entire Agreement.....	57
13.6	Recording.....	57
13.7	Forward Contract.....	57
13.8	Governing Law.....	57
13.9	Attorneys' Fees.....	57
13.10	General.....	57
13.11	Severability.....	58

13.12	Counterparts.....	58
13.13	Notices.....	58
13.14	Mobile Sierra.....	58
EXHIBIT A PROJECT DESCRIPTION INCLUDING DESCRIPTION OF SITE.....		1
EXHIBIT B MILESTONE SCHEDULE.....		1
EXHIBIT C FORM OF LETTER OF CREDIT.....		1
EXHIBIT D FORM OF GUARANTY.....		1
EXHIBIT E COMMERCIAL OPERATION CERTIFICATE.....		1
EXHIBIT F FORM OF QUARTERLY PROGRESS REPORT.....		1
EXHIBIT G OUTAGE NOTIFICATION FORM.....		1

COVER SHEET

This Power Purchase Agreement is made as of the following date: January 25, 2011. This Power Purchase Agreement and all exhibits, schedules, appendices, and any written supplements hereto, any designated collateral, credit support or margin agreement or similar arrangement between the Parties as well as all written and signed amendments and modifications thereto shall be a part of, and shall be referred to as, the "Agreement." The Parties to this Agreement (hereinafter individually a "Party" and collectively the "Parties") are the following:

Name: NRG Solar Borrego I LLC ("Seller")

Name: San Diego Gas & Electric Company ("Buyer")

All Notices:

All Notices:

All Notices:

Street: 5790 Fleet Street, Suite 200
City: Carlsbad, CA Zip: 92009
Attn: Contract Administration
Phone: (760) 710-2189
Facsimile: (760) 918-0310
Duns: 82-906-8928
Federal Tax ID Number: 26-3268182

All Notices:

Street: 8315 Century Park Court
City: San Diego, CA Zip: 92123
Attn: Contract Administration
Phone: (858) 650-6176
Facsimile: (858) 650-6190
Duns: 006911457
Federal Tax ID Number: 95-1184800

Invoices:

Attn: Keith Richards
Phone: (760) 710-2146
Facsimile: (760) 918-0310

Invoices:

San Diego Gas & Electric Company
8315 Century Park Ct.
San Diego, California 92123-1593
Attn: Energy Accounting Manager
Phone: (858) 650-6177
Facsimile: (858) 650-6190

Scheduling:

To be provided by Seller

Scheduling:

San Diego Gas & Electric Company
8315 Century Park Ct.
San Diego, California 92123-1593
Attn: Transaction Scheduling Manager
Phone: (858) 650-6160
Facsimile: (858) 650-6191

Payments:

Attn: Keith Richards
Phone: (760) 710-2146
Facsimile: (760) 918-0310

Payments:

San Diego Gas & Electric Company
PO Box 25110
Santa Ana, CA 92799-5110
Attn: Mail Payments
Phone: (619) 696-4521
Facsimile: (619) 696-4899

Wire Transfer:

BNK: Citibank
ABA: 021000089
ACCT: 30773952
Confirmation:
FAX:

Wire Transfer:

BNK: Union Bank of California
for: San Diego Gas & Electric Company
ABA: Routing # 122000496
ACCT: #4430000352
Confirmation: SDG&E, Major Markets
FAX:(213) 244-8316

Credit and Collections:

Attn: Arlene Spangler
Phone: (609) 524-4846
Facsimile:

Credit and Collections:

San Diego Gas & Electric Company, Major Markets
555 W. Fifth Street, ML 10E3
Los Angeles, CA 90013-1011
Attn.: Major Markets, Credit and Collections

With additional Notices of an Event of Default or
Potential Event of Default to:

Attn: Michael Brannick
Phone: (609) 524-4598
Facsimile: (609) 524-4589

Manager
Fax No.: (213) 244-8316
Phone: (213) 244-4343

With additional Notices of an Event of Default or
Potential Event of Default to:

San Diego Gas & Electric Company
8330 Century Park Ct.
San Diego, CA 92123
Attn: General Counsel
Phone: (858) 650-6141
Facsimile: (858) 650-6106

GENERAL TERMS AND CONDITIONS

ARTICLE ONE: GENERAL DEFINITIONS

1.1 General. The following terms shall have the following meaning for purposes of this Agreement.

“AAA” means the American Arbitration Association.

“Affiliate” means, with respect to any person, any other person (other than an individual) that, directly or indirectly, through one or more intermediaries, controls, or is controlled by, or is under common control with, such person. For this purpose, “control” means the direct or indirect ownership of fifty percent (50%) or more of the outstanding capital stock or other equity interests having ordinary voting power.

“Agreement” has the meaning set forth in the preamble to the Cover Sheet.

“Arbitration” has the meaning set forth in Section 12.3.

“As-Available” means a Product for which, subject to the terms of this Agreement, Seller is excused from selling and delivering the Product to Buyer, and Seller shall not be liable to Buyer for any damages determined pursuant to Section 3.1(h) of the Agreement, in the event that Seller fails to deliver the Product to Buyer for any of the following reasons:

- (a) if the Project is unavailable as a result of a Forced Outage (as defined in the NERC Generating Unit Availability Data System (GADS) Forced Outage reporting guidelines) and such Forced Outage is not the result of Seller’s negligence or willful misconduct;
- (b) Force Majeure;
- (c) by the Buyer’s failure to perform;
- (d) by a Planned Outage of the Project;
- (e) a reduction in output as ordered under Dispatch Down Periods; or
- (f) insufficient solar power for the Project to generate energy as determined by the solar standards utilized by other solar producers in the vicinity of the Project, as adjusted to reflect the technology employed by the Project.

“Availability Incentive Payments” shall mean Availability Incentive Payments as defined in FERC filing ER09-1064 or such other similar term as modified and approved by FERC thereafter to be incorporated in the CAISO Tariff or otherwise applicable to CAISO.

“Availability Standards” shall mean Availability Standards as defined in FERC filing ER09-1064 or such other similar term as modified and approved by FERC thereafter to be incorporated in the CAISO Tariff or otherwise applicable to CAISO.

“Bankrupt” means with respect to any entity, such entity that (a) files a petition or otherwise commences, authorizes or acquiesces in the commencement of a proceeding or cause of action under any bankruptcy, insolvency, reorganization or similar Law, (b) has any such petition filed or commenced against it which remains unstayed or undismissed for a period of ninety (90) days, (c) makes an assignment or any general arrangement for the benefit of creditors, (d) otherwise becomes bankrupt or insolvent (however evidenced), (e) has a liquidator, administrator, receiver, trustee, conservator or similar official appointed with respect to it or any substantial portion of its property or assets, or (f) is generally unable to pay its debts as they fall due.

“Business Day” means any day except a Saturday, Sunday, or a Federal Reserve Bank holiday and shall be between the hours of 8:00 a.m. and 5:00 p.m. local time for the relevant Party’s principal place of business where the relevant Party, in each instance unless otherwise specified, shall be the Party from whom the Notice, payment or delivery is being sent and by whom the Notice or payment or delivery is to be received.

“Buyer” has the meaning set forth on the Cover Sheet.

“Buyer Fronted Expenses” has the meaning set forth in Section 4.5.

“CAISO” means the California Independent System Operator Corporation or any successor entity performing similar functions.

“CAISO Charges Invoice” has the meaning set forth in Section 3.3(b)(iv).

“CAISO Grid” means the system of transmission lines and associated facilities of the Participating Transmission Owners that have been placed under the CAISO’s operational control.

“CAISO Tariff” means the CAISO Operating Agreement and Tariff, including the rules, protocols, procedures and standards attached thereto, as the same may be amended or modified from time-to-time and approved by FERC.

“California Renewables Portfolio Standard” means the Renewables Portfolio Standard of California under California Senate Bills 1078 and 107, as codified in California Public Utilities Code Sections 387, 390.1, and 399.25 and Article 16 (commencing with Section 399.11) of Chapter 2.3 of Part 1 of Division 1, as such provisions are amended or supplemented from time to time.

“Capacity Attributes” means any current or future defined characteristic, certificate, tag, credit, or ancillary service attribute, whether general in nature or specific as to the location or any other attribute of the Project that is intended to value any aspect of the capacity of the Project to produce Energy or ancillary services, including but not limited to any related accounting construct, so that the Contract Capacity of the Project may be counted toward a Resource

Adequacy obligation or similar measure in respect to the capacity of the Project to generate Energy by the CPUC, the CAISO, the FERC, or any other entity invested with the authority under federal or state Law, to require Buyer to procure, or to procure at Buyer's expense, Resource Adequacy or other similar products.

"CEC" means the California Energy Commission or its successor agency.

"CEC Certification and Verification" means that the CEC has certified (or, with respect to periods before the Project has received its final certification from the CEC, that the CEC has pre-certified) that the Project is an ERR for purposes of the California Renewables Portfolio Standard and that all Energy produced by the Project qualifies as generation from an ERR for purposes of the Agreement.

"Claims" has the meaning set forth in Section 11.2(a).

"Commercial Operation" means that (a) the Project is operating and able to produce and deliver Energy to the Delivery Point for sale to Buyer pursuant to the terms of this Agreement; (b) Seller shall have satisfied the requirements set forth in the Certificate of Commercial Operation in the form attached as Exhibit E; (c) Seller shall have delivered true, correct, and complete Certificates of Commercial Operation; (d) Seller shall have delivered to Buyer the Delivery Term Security required under Article 8; and (e) Seller has received all local, state and federal Governmental Approvals and other approvals as may be required by Law for the construction, operation and maintenance of the Project, including approvals, if any, required under the California Environmental Quality Act for the Project and related interconnection facilities.

"Commercial Operation Date" means the date on which Seller achieves Commercial Operation for the Project.

"Compliance Expenditure Cap" means an amount equal to One Hundred Thousand dollars (\$100,000) per Contract Year or Two Million dollars (\$2,000,000) over the term of the Agreement.

"Conditions Precedent" has the meaning set forth in Section 2.3.

"Construction Period Security" shall mean the Performance Assurance that Seller is required to maintain during the period from the CP Satisfaction Date until the commencement of the Delivery Term, as specified in Article 8, to secure performance of its obligations hereunder.

"Contract Capacity" has the meaning set forth in Section 3.1(f).

"Contract Quantity" has the meaning set forth in Section 3.1(e).

"Contract Year" means, with respect to the first Contract Year, the period commencing on the Commercial Operation Date and ending on the last day of the month that is twelve (12) complete months thereafter, and, with respect to each subsequent Contract Year, the twelve (12) month period commencing on the anniversary of the first day of the month following the Commercial Operation Date.

“Costs” means, with respect to the Non-Defaulting Party, brokerage fees, commissions and other similar third party transaction costs and expenses reasonably incurred by such Party after using commercially reasonable efforts to mitigate or eliminate such costs, either in terminating any arrangement pursuant to which it has hedged its obligations or entering into new arrangements which replace a Terminated Transaction; and all reasonable attorneys’ fees and expenses incurred by the Non-Defaulting Party in connection with such Terminated Transaction.

“Cover Sheet” means the document that precedes Article 1: General Definitions to this Agreement.

“CP Satisfaction Date” shall mean the date on which all of the Conditions Precedent have been satisfied (or waived in writing by the Party described in Section 2.4).

“CPUC” or “Commission or successor entity” means the California Public Utilities Commission, or successor entity.

“CPUC Approval” means a final and non-appealable order of the CPUC, without conditions or modifications unacceptable to the Parties, or either of them, which contains the following terms:

(a) approves this Agreement in its entirety, including payments to be made by the Buyer, subject to CPUC review of the Buyer’s administration of the Agreement; and

(b) finds that any procurement pursuant to this Agreement is procurement from an eligible renewable energy resource for purposes of determining Buyer’s compliance with any obligation that it may have to procure eligible renewable energy resources pursuant to the California Renewables Portfolio Standard (Public Utilities Code Section 399.11 *et seq.*), Decision 03-06-071, or other applicable Law.

CPUC Approval will be deemed to have occurred on the date that a CPUC decision containing such findings becomes final and non-appealable.

“Credit Rating” means, with respect to any entity, the rating then assigned to such entity’s unsecured, senior long-term debt obligations (not supported by third party credit enhancements) by S&P or Moody’s.

“Daily Delay Damages” means an amount equal to (a) the Construction Period Security amount required hereunder, divided by (b) the number of days in the Project Cure Period.

“Day-Ahead Schedule” has the meaning set forth in Section 3.3(e). “Defaulting Party” means the Party that is subject to an Event of Default.

“Default Rate” means for any date, the lesser of (a) the per annum rate of interest equal to the prime lending rate as may from time to time be published in *The Wall Street Journal* under “Money Rates” on such day (or if not published on such day on the most recent preceding day on which published), plus two percent (2%) and (b) the maximum rate permitted by applicable Law.

“Delivered Energy” means all Energy produced from the Project and delivered to Buyer at the Delivery Point as measured in MWh by the CAISO revenue meter of the Project, net of all Electrical Losses.

“Delivery Point” means the point at which Buyer receives Seller’s Product, as set forth in Section 3.1(d).

“Delivery Term” has the meaning set forth in Section 3.1(c).

“Delivery Term Security” shall mean the Performance Assurance that Seller is required to maintain during the Delivery Term, as specified in Article 8, to secure performance of its obligations hereunder.

“Development Period Security” shall mean the Performance Assurance that Seller is required to maintain during the period from the Execution Date to the CP Satisfaction Date, as specified in Article 8, to secure performance of its obligations hereunder.

“Disclosing Party” has the meaning set forth in Section 13.1(a).

“Disclosure Order” has the meaning set forth in Section 13.1(a).

“Dispatch Down Period” means the period of curtailment of delivery of Product from the Project resulting from (a) curtailments ordered by the CAISO (whether directly or through the Scheduling Coordinator or the Participating Transmission Owner), for any reason, including but not limited to, any system emergency, as defined in the CAISO Tariff (“System Emergency”), (b) curtailments ordered by the Participating Transmission Owner for any reason and curtailment in accordance with Seller’s obligations under its interconnection agreement with the Participating Transmission Owner; or (c) curtailments ordered by the Participating Transmission Owner as a result of scheduled or unscheduled maintenance on the Participating Transmission Owner’s transmission facilities that prevents (i) Buyer from receiving or (ii) Seller from delivering Delivered Energy at the Delivery Point; provided, however, Dispatch Down Periods shall not include periods of curtailment of delivery of Product from the Project resulting from economic curtailment where Buyer (as the Scheduling Coordinator) submits an economic bid in the applicable CAISO market that results in an otherwise available Product not being scheduled or awarded in such CAISO market.

“DUNS” means the Data Universal Numbering System, which is a unique nine character identification number provided by Dun and Bradstreet.

“Early Termination Date” has the meaning set forth in Section 5.2.

“EIRP” or “Eligible Intermittent Resource Protocol” means the Eligible Intermittent Resource Protocol, as may be amended from time to time, as set forth in the CAISO Tariff.

“Electrical Losses” means all electrical losses applicable to the transmission of Product to the Delivery Point, but only to the extent the CAISO revenue meter is not already adjusted to reflect such losses, including if applicable, but not limited to, any transmission or transformation losses between the CAISO revenue meter and the Delivery Point.

“Eligible Renewable Energy Resource” or “ERR” has the meaning set forth in California Public Utilities Code Section 399.11, *et seq.*, as amended or supplemented from time to time.

“Energy” means electric energy measured in MWh and net of Station Service (unless otherwise specified).

“Energy Price” has the meaning set forth in Section 4.1(a).

“EPC Contract” means the Seller’s engineering, procurement and construction contract with the EPC Contractor.

“EPC Contractor” means an engineering, procurement, and construction contractor, selected by Seller, with substantial experience in the engineering, procurement, and construction of power plants of the same type of facility as Seller’s.

“Equitable Defenses” means any bankruptcy, insolvency, reorganization or other Laws affecting creditors’ rights generally and, with regard to equitable remedies, the discretion of the court before which proceedings may be pending to obtain same.

“Event of Default” has the meaning set forth in Section 5.1.

“Execution Date” means the date hereof as set forth in the preamble of the Cover Sheet.

“Executive(s)” has the meaning set forth in Section 12.2(a).

“FERC” means the Federal Energy Regulatory Commission or any successor government agency.

“Force Majeure” means any event or circumstance which wholly or partly prevents or delays the performance of any material obligation arising under this Agreement but only to the extent (i) such event is not within the reasonable control, directly or indirectly, of the Party seeking to have its performance obligation(s) excused thereby, (ii) the Party seeking to have its performance obligation(s) excused thereby has taken all reasonable precautions and measures in order to prevent or avoid such event or mitigate the effect of such event on such Party’s ability to perform its obligations under this Agreement and which by the exercise of due diligence such Party could not reasonably have been expected to avoid and which by the exercise of due diligence it has been unable to overcome, and (iii) such event is not the direct or indirect result of the fault or negligence of the Party seeking to have its performance obligations excused thereby.

(a) Subject to the foregoing, events that could qualify as Force Majeure include, but are not limited to the following:

(i) acts of God, flooding, lightning, landslide, earthquake, fire, drought, explosion, epidemic, quarantine, storm, hurricane, tornado, volcanic eruption, other natural disaster or unusual or extreme adverse weather-related events;

(ii) war (declared or undeclared), riot or similar civil disturbance, acts of the public enemy (including acts of terrorism), sabotage, blockade, insurrection, revolution, expropriation or confiscation;

(iii) except as set forth in subpart (b)(vii) below, strikes, work stoppage or other labor disputes (in which case the affected Party shall have no obligation to settle the strike or labor dispute on terms it deems unreasonable); or

(iv) through no fault of Seller, the Project is no longer eligible for the California Revenue and Taxation Code Section 73 property tax exclusion for solar equipment and any such lost incentive materially increases Seller's expenses which results in a deterioration of Seller's financial condition that is capable of being declared a default under any agreement between Seller and its financing providers. For purposes of Section 5.8, Seller shall be deemed to be the non-claiming party with respect to a claim of Force Majeure under this subsection (a)(iv), and shall have the right to terminate this Agreement in accordance with Section 5.8 if the circumstances described in the subsection (a)(iv) are not resolved within six (6) months after the commencement of such circumstances, unless Buyer has agreed in writing, on terms and conditions reasonably acceptable to Seller, to reimburse Seller or to pay directly 100% of such lost property tax incentive.

(b) Force Majeure shall not be based on:

(i) Buyer's inability economically to use or resell the Product purchased hereunder;

(ii) Seller's ability to sell the Product at a price greater than the price set forth in this Agreement;

(iii) Seller's inability to obtain Governmental Approvals or other approvals of any type for the construction, operation, or maintenance of the Project;

(iv) a lack of wind, sun or other fuel source of an inherently intermittent nature, except to the extent caused by an event or circumstance that qualifies as Force Majeure;

(v) Seller's inability to obtain sufficient labor, equipment, materials, or other resources to build or operate the Project, except to the extent Seller's inability to obtain sufficient labor, equipment, materials, or other resources is caused by an event of Force Majeure of the specific type described in any of subsections (a)(i) through (a)(iii) above;

(vi) Seller's inability to obtain additional funds, including funds authorized by a state or the federal government or agencies thereof, to supplement the payments made by Buyer pursuant to this Agreement;

(vii) a strike, work stoppage or labor dispute limited only to any one or more of Seller, Seller's Affiliates, the EPC Contractor or subcontractors thereof or any other third party employed by Seller to work on the Project;

(viii) any equipment failure except if such equipment failure is caused solely by an event of Force Majeure of the specific type described in any of subsections (a)(i) through (a)(iii) above; or

(ix) a Party's inability to pay amounts due to the other Party under this Agreement, except if such inability is caused solely by a Force Majeure event that disables physical or electronic facilities necessary to transfer funds to the payee Party.

"Forced Outage" means any unplanned reduction or suspension of production of Product from the Project or unavailability of the Project in whole or in part that is not a Planned Outage or a willful withholding of Product when the Project is otherwise capable of delivering Product under Good Industry Practices.

"GAAP" has the meaning set forth in Section 13.4.

"Gains" means with respect to any Party, an amount equal to the present value of the economic benefit to it, if any (exclusive of Costs), resulting from the termination of this Agreement for the remaining Delivery Term, determined in a commercially reasonable manner, subject to Section 5.2 hereof. Factors used in determining economic benefit may include, without limitation, reference to information either available to it internally (if comparable third party information is not reasonably available) or supplied by one or more third parties, including, without limitation, quotations (either firm or indicative) of relevant rates, prices, yields, yield curves, volatilities, spreads or other relevant market data in the relevant markets market referent prices for renewable power set by the CPUC, comparable transactions, forward price curves based on economic analysis of the relevant markets, settlement prices for comparable transactions at liquid trading hubs (e.g., NYMEX), all of which should be calculated for the remaining term of this Agreement and include the value, if any, of Capacity Attributes and Green Attributes.

"Good Industry Practice" means those practices, methods and acts that would be implemented and followed by prudent operators of electric transmission facilities (with respect to Buyer) or prudent operators of electric generation facilities similar to the Project (with respect to Seller) in the Western United States during the relevant time period, which practices, methods and acts, in the exercise of prudent and responsible professional judgment in the light of the facts known at the time the decision was made, could reasonably have been expected to accomplish the desired result consistent with good business practices, reliability and safety, and shall include, at a minimum, those professionally responsible practices, methods and acts described in the preceding sentence that comply with manufacturers' warranties, restrictions in this Agreement, and the requirements of Governmental Authorities, WECC standards, the CAISO and applicable Law. Good Industry Practice is not intended to be the optimum practice, method or act to the exclusion of all others, but rather is intended to be any of the practices, methods and/or actions generally accepted in the region.

"Governmental Approval" means all authorizations, consents, approvals, waivers, exceptions, variances, filings, permits, orders, licenses, exemptions and declarations of or with any governmental entity and, with respect to the Seller, shall include those siting and operating

permits and licenses, and any of the foregoing under any applicable environmental Law, that are required for the construction, use, and operation of the Project.

“Governmental Authority” means any federal, state, local or municipal government, governmental department, commission, board, bureau, agency, or instrumentality, or any judicial, regulatory or administrative body, having jurisdiction as to the matter in question.

“Governmental Charges” has the meaning set forth in Section 9.2.

“Green Attributes” means any and all credits, benefits, emissions reductions, offsets, and allowances, howsoever entitled, attributable to the generation from the Project, and its avoided emission of pollutants. Green Attributes include but are not limited to Renewable Energy Credits, as well as: (1) any avoided emission of pollutants to the air, soil or water such as sulfur oxides (SO_x), nitrogen oxides (NO_x), carbon monoxide (CO) and other pollutants; (2) any avoided emissions of carbon dioxide (CO₂), methane (CH₄), nitrous oxide, hydrofluorocarbons, perfluorocarbons, sulfur hexafluoride and other greenhouse gases (GHGs) that have been determined by the United Nations Intergovernmental Panel on Climate Change, or otherwise by Law, to contribute to the actual or potential threat of altering the Earth’s climate by trapping heat in the atmosphere;¹ and (3) the reporting rights to these avoided emissions, such as Green Tag Reporting Rights. Green Tag Reporting Rights are the right of a Green Tag Purchaser to report the ownership of accumulated Green Tags in compliance with federal or state Law, if applicable, and to a federal or state agency or any other party at the Green Tag Purchaser’s discretion, and include without limitation those Green Tag Reporting Rights accruing under Section 1605(b) of The Energy Policy Act of 1992 and any present or future federal, state, or local Law, regulation or bill, and international or foreign emissions trading program. Green Tags are accumulated on a MWh basis and one Green Tag represents the Green Attributes associated with one (1) MWh of Energy. Green Attributes do not include (i) any energy, capacity, reliability or other power attributes from the Project, (ii) production tax credits associated with the construction or operation of the Project and other financial incentives in the form of credits, reductions, or allowances associated with the Project that are applicable to a state or federal income taxation obligation, (iii) fuel-related subsidies or “tipping fees” that may be paid to Seller to accept certain fuels, or local subsidies received by the generator for the destruction of particular preexisting pollutants or the promotion of local environmental benefits, or (iv) emission reduction credits encumbered or used by the Project for compliance with local, state, or federal operating and/or air quality permits. If the Project is a biomass or biogas facility and Seller receives any tradable Green Attributes based on the greenhouse gas reduction benefits or other emission offsets attributed to its fuel usage, it shall provide Buyer with sufficient Green Attributes to ensure that there are zero net emissions associated with the production of electricity from the Project.

“Guaranteed Commercial Operation Date” or “GCOD” means July 31, 2012, as may be extended pursuant to Section 3.9(c)(ii).

¹ Avoided emissions may or may not have any value for GHG compliance purposes. Although avoided emissions are included in the list of Green Attributes, this inclusion does not create any right to use those avoided emissions to comply with any GHG regulatory program.

“Guaranteed Energy Production” has the meaning set forth in Section 3.1(e).

“Guarantor” means, with respect to Seller, any person that (i) does not already have any material credit exposure to Buyer under any other agreements, guarantees, or other arrangements at the time its Guaranty is issued, (ii) is an Affiliate of Seller, or other third party reasonably acceptable to Buyer, (iii) has a Credit Rating of BBB- or better from S&P or a Credit Rating of Ba3 or better from Moody’s, (iv) has a tangible net worth of at least US\$500,000,000, (v) is incorporated or organized in a jurisdiction of the United States and is in good standing in such jurisdiction, and (vi) executes and delivers a Guaranty for the benefit of Buyer substantially in the form attached hereto as Exhibit D, or in any other form reasonably acceptable to Buyer.

“Guaranty” means a guaranty from a Guarantor provided for the benefit of Buyer substantially in the form attached hereto as Exhibit D, or in any other form reasonably acceptable to Buyer.

“Imbalance Energy” means the amount of Energy, in any given settlement period, by which the amount of Delivered Energy deviates from the amount of Scheduled Energy.

"Initial Energy Delivery Date" means the first day that Test Energy is delivered.

“Initial Negotiation End Date” has the meaning set forth in Section 12.2(a).

“Interconnection Facilities” means the facilities, which include all apparatus installed pursuant to the Participating Transmission Owner’s facility connection requirements, to which Seller shall be able to interconnect and deliver Energy from the Project to and at the Delivery Point and Buyer shall be able to transmit Energy from the Delivery Point, including, but not limited to, network and other transmission upgrades, connection, transformation, switching, metering, communications, control, and safety equipment, such as equipment required pursuant to Good Industry Practices and in accordance with any agreements entered into by Seller necessary for interconnection to protect the Participating Transmission Owner’s electric system (or other systems to which the Participating Transmission Owner’s electric system is connected, including the CAISO Grid) and the Participating Transmission Owner’s or Transmission Provider’s, as applicable, customers from faults occurring at the Project.

“Interest Amount” means, with respect to an Interest Period, the amount of interest derived from: (x) the sum of (a) the principal amount of Performance Assurance in the form of cash held by Buyer during that Interest Period, and (b) the sum of all accrued and unpaid Interest Amounts accumulated prior to such Interest Period; multiplied by (y) the Interest Rate in effect on the first day of the Interest Period; multiplied by (z) the number of days in that Interest Period; (u) divided by 360.

“Interest Payment Date” means the last Business Day of each calendar year.

“Interest Period” means the monthly period beginning on the first day of each month and ending on the last day of each month or the shorter period during which Performance Assurance in the form of cash is held by Buyer.

“Interest Rate” means the rate per annum equal to the “Monthly” Commercial Paper rate (Prime, 3 months) published the prior month in the Federal Reserve Statistical Release, or its successor publication.

“Investment Tax Credit” or “ITC” means the tax credit for property described in Section 48(a)(3)(A)(i) of the Internal Revenue Code of 1986, as it may be amended from time to time.

“Law” means any statute, law, treaty, rule, regulation, ordinance, code, Governmental Approval, enactment, injunction, order, writ, decision, authorization, judgment, decree or other legal or regulatory determination or restriction by a court or Governmental Authority of competent jurisdiction, including any of the foregoing that are enacted, amended, or issued after the Execution Date, and which becomes effective during the Delivery Term; or any binding interpretation of the foregoing.

“Letter(s) of Credit” one or more irrevocable, transferable standby letters of credit issued by a U.S. commercial bank or a foreign bank with a U.S. branch with such bank having a Credit Rating of at least A- from S&P or A3 from Moody’s, in substantially the form as contained in Exhibit C to this Agreement, or in any other form reasonably acceptable to Buyer.

“Licensed Professional Engineer” means a person acceptable to Buyer in its reasonable judgment who (i) is licensed to practice engineering in California, (ii) has training and experience in the power industry specific to the technology of the Project, (iii) has no economic relationship, association, or nexus with Seller or Buyer, other than to meet the obligations of Seller pursuant to this Agreement, (iv) is not a representative of a consultant, engineer, contractor, designer or other individual involved in the development of the Project or of a manufacturer or supplier of any equipment installed at the Project, and (v) is licensed in an appropriate engineering discipline for the required certification being made.

“Losses” means with respect to any Party, an amount equal to the present value of the economic loss to it, if any (exclusive of Costs), resulting from a Terminated Transaction for the remaining term of this Agreement, determined in a commercially reasonable manner. Factors used in determining the loss of economic benefit may include, without limitation, reference to information either available to it internally (if comparable third party information is not reasonably available) or supplied by one or more third parties including without limitation, quotations (either firm or indicative) of relevant rates, prices, yields, yield curves, volatilities, spreads or other relevant market data in the relevant markets, market referent prices for renewable power set by the CPUC, comparable transactions, forward price curves based on economic analysis of the relevant markets, settlement prices for comparable transactions at liquid trading hubs (e.g. NYMEX), all of which should be calculated for the remaining term of this Agreement and include the value, if any, of Capacity Attributes, and Green Attributes.

“Manager” has the meaning set forth in Section 12.2(a).

“Milestones” has the meaning set forth in Section 3.9(b)(i).

“Monthly Energy Payment” has the meaning set forth in Section 4.1(c).

“Moody’s” means Moody’s Investor Services, Inc., or its successor.

“MRTU” or “Market Redesign and Technology Upgrade” means the locational marginal pricing market system to be governed by the CAISO MRTU Tariff approved by FERC.

“MWh” means megawatt-hour.

“Negative Imbalance Energy” has the meaning set forth in Section 4.2.

“NERC” means the North American Electric Reliability Corporation or a successor organization that is responsible for establishing reliability criteria and protocols.

“NERC Holiday” means any of the following holidays: New Year’s Day, Memorial Day, Independence Day, Labor Day, Thanksgiving Day, and Christmas Day. Three of these days, Memorial Day, Labor Day, and Thanksgiving Day, occur on the same day each year. Memorial Day is the last Monday in May; Labor Day is the first Monday in September; and Thanksgiving Day is the fourth (4th) Thursday in November. New Year’s Day, Independence Day, and Christmas Day occur on the same date each year, but in the event any of these holidays occur on a Sunday, the “NERC Holiday” is celebrated on the Monday immediately following that Sunday; and if any of these holidays occur on a Saturday, the “NERC Holiday” remains on that Saturday.

“Non-Availability Charges” shall mean Non-Availability Charges as defined in FERC filing ER09-1064 or such other similar term as modified and approved by FERC thereafter to be incorporated in the CAISO Tariff or otherwise applicable to CAISO.

“Non-Defaulting Party” has the meaning set forth in Section 5.2.

“Notice” shall, unless otherwise specified in the Agreement, mean written communications by a Party to be delivered by hand delivery, United States mail, overnight courier service, facsimile or electronic messaging (e-mail).

“Notice to Proceed” or “NTP” means the notice provided by Seller to the EPC Contractor following execution of the EPC Contract between Seller and such EPC Contractor and satisfaction of all conditions precedent to performance of such contract, by which Seller authorizes such EPC Contractor to commence and complete performance of the work under the EPC Contract without any delay or waiting periods.

“Outage Notification Form” means the completed document from Seller notifying Buyer of an outage of the Project substantially in the form attached hereto as Exhibit G. Buyer reserves the right to reasonably revise or change the form upon Notice to Seller.

“Participating Intermittent Resource” shall have the meaning set forth in the CAISO Tariff.

“Participating Transmission Owner” or “Participating TO” means an entity that (a) owns, operates and maintains transmission lines and associated facilities and/or has entitlements to use certain transmission lines and associated facilities and (b) has transferred to the CAISO operational control of such facilities and/or entitlements to be made part of the CAISO Grid. For purposes of this Agreement, the Participating Transmission Owner is San Diego Gas & Electric Company.

“Party” or “Parties” means the Buyer or Seller individually, or to both collectively.

“Performance Assurance” means collateral provided by Seller to Buyer to secure Seller’s obligations hereunder and includes Development Period Security, Construction Period Security, and Delivery Term Security.

“Performance Measurement Period” has the meaning set forth in Section 3.1(e).

“Planned Outage” means any planned reduction or suspension of the electrical output from the Project or unavailability of the Project in whole or in part as a result of the inspection, maintenance, repair, or replacement of equipment that is scheduled in accordance with Section 3.7(b).

“Positive Imbalance Energy” has the meaning set forth in Section 4.2.

“Product” has the meaning set forth in Section 3.1(a).

“Project” means all of the solar electric generating units, the Site at which the generating facility is located, and the other assets, tangible and intangible, that compose the generation facility as more particularly described on Exhibit A.

“Project Cure Period” has the meaning set forth in Section 3.9(c)(i).

“Quarterly Progress Report” means the report similar in form and content attached hereto as Exhibit F, as may be modified from time to time to meet applicable CPUC requirements.

“Recording” has the meaning set forth in Section 13.6.

“Reductions” has the meaning set forth in Section 3.2(c).

“Referral Date” has the meaning set forth in Section 12.2(a).

“Remedial Action Plan” has the meaning provided in Section 3.9(b)(ii).

“Renewable Energy Credit” has the meaning set forth in California Public Utilities Code Section 399.12(f), as may be amended from time to time or as further defined or supplemented by Law.

“Replacement Price” means the price at which Buyer, acting in a commercially reasonable manner, purchases for delivery at the Delivery Point (or any other reasonably equivalent delivery point for Buyer) a replacement for any Product (including its associated Green Attributes) that was not delivered or Scheduled by Seller, plus (i) costs reasonably incurred by Buyer in purchasing such replacement Product and (ii) additional transmission charges, if any, reasonably incurred by Buyer for such replacement Product, or absent a purchase, the market price at the Delivery Point (or any other reasonably equivalent delivery point for Buyer) for such replacement Product for the hours impacted by such failure to deliver or Schedule such Product as determined by Buyer in a commercially reasonable manner. Without duplication of any costs included in the foregoing sentence, Replacement Price also

shall include all CAISO and other charges and penalties calculated in dollars per megawatt hour with respect to the deviation from the Scheduled supply resulting from Seller's failure to deliver or Schedule; provided, however, in no event shall such price include any ratcheted demand or similar charges, nor shall Buyer be required to utilize or change its utilization of its owned or controlled assets or market positions to minimize Seller's liability. For the purposes of this definition, Buyer shall be considered to have purchased replacement Product to the extent Buyer shall have entered into one or more arrangements in a commercially reasonable manner whereby Buyer repurchases its obligation to sell and deliver the Product to another party. If for any reason a Replacement Price is unavailable when Seller fails to deliver or Schedule Product, then the Replacement Price for the hours when a Replacement Price is unavailable shall be the last available Replacement Price together with any charges and penalties allocated to Buyer during such time.

"Resource Adequacy" means the procurement obligation of load serving entities, including Buyer, as such obligations are described in CPUC Decisions D.04-10-035 and D.05-10-042 and subsequent CPUC decisions addressing Resource Adequacy issues, as those obligations may be altered from time to time in the CPUC Resource Adequacy Rulemakings (R.) 04-04-003 and (R.) 05-12-013 or by any successor proceeding, and all other applicable Resource Adequacy obligations established by any other entity with jurisdiction over Buyer, including the CAISO.

"Sales Price" means the price at which Seller, acting in a commercially reasonable manner, resells any Product not received by Buyer, deducting from such proceeds any (i) costs reasonably incurred by Seller in reselling such Product including all costs charged by CAISO to Schedule and deliver the Product into the CAISO System, and (ii) additional transmission charges, if any, reasonably incurred by Seller in Scheduling and delivering such Product to the third party purchasers, or absent a sale despite commercially reasonable efforts to resell the Product, zero. The Sales Price shall also be reduced by all CAISO and other costs, charges and penalties with respect to the deviation from the Scheduled supply, in each case, resulting from Buyer's failure to take Product and calculated in dollars per megawatt hour; provided, however, in no event shall such price include any ratcheted demand or similar charges, nor shall Seller be required to utilize or change its utilization of its owned or controlled assets, including contractual assets, or market positions to minimize Buyer's liability. The Sales Price may be less than zero.

"S&P" means the Standard & Poor's Rating Group (a division of McGraw-Hill, Inc.) or its successor.

"Schedule" means the actions of Seller, Buyer and/or their designated representatives, or Scheduling Coordinators, including each Party's Transmission Providers, if applicable, of notifying, requesting and confirming to each other and the CAISO the quantity and type of Product to be delivered on any given day or days at a specified Delivery Point.

"Scheduling Coordinator" or "SC" means an entity certified by the CAISO as qualifying as a Scheduling Coordinator pursuant to the CAISO Tariff, for the purposes of undertaking the functions specified in "Responsibilities of a Scheduling Coordinator," of the CAISO Tariff, as amended from time-to-time.

“Scheduled Energy” means the Energy that clears under the applicable CAISO market based on the final Schedule developed in accordance with this Agreement, the operating procedures developed by the Parties pursuant to Section 3.10, and the applicable CAISO Tariff, protocols and Scheduling practices.

“SEC” means the U.S. Securities and Exchange Commission.

“Seller” shall have the meaning set forth on the Cover Sheet.

“Settlement Amount” means, with respect to the Non-Defaulting Party, the Losses or Gains, and Costs, expressed in U.S. Dollars, which such Party incurs as a result of the liquidation of a Terminated Transaction pursuant to Sections 5.2 and 5.3.

“Site” shall mean the location of the Project as described in Exhibit A.

“Standard Capacity Product Compliance Expenditure Cap” means an amount equal to One Hundred and Fifty Thousand dollars (\$150,000) per Contract Year or Four Hundred and Fifty Thousand dollars (\$450,000) over the entire term of this Agreement.

“Station Service” means the electric energy produced by the Project that is used within the Project to power the lights, motors, control systems and other auxiliary electrical loads that are necessary for operation of the Project.

“Terminated Transaction” means the termination of this Agreement in accordance with Section 5.2 of this Agreement.

“Termination Payment” has the meaning set forth in Section 5.2.

“Test Energy” means the Energy that is delivered to and received from the Delivery Point and generated by the Project, so long as such amount is 1MW or more, and necessary for testing and/or commissioning of such units after initial synchronization and prior to Commercial Operation.

“TOD” means time of delivery of Delivered Energy from Seller to Buyer.

“TOD Factors” has the meaning set forth in Section 4.1(b).

“TOD Period” has the meaning set forth in Section 4.1(b).

“Transmission Provider” means any entity or entities transmitting or transporting the Product on behalf of Seller or Buyer to or from the Delivery Point.

“WECC” means the Western Electricity Coordinating Council or successor agency.

“WREGIS” means the Western Renewable Energy Generating Information System or any successor renewable energy tracking program.

1.2 Interpretation. The following rules of interpretation shall apply:

- (a) The term “month” shall mean a calendar month unless otherwise indicated, and a “day” shall be a 24-hour period beginning at 12:00:01 a.m. Pacific Prevailing Time and ending at 12:00:00 midnight Pacific Prevailing Time; provided that a “day” may be 23 or 25 hours on those days on which daylight savings time begins and ends.
- (b) Unless otherwise specified herein, all references herein to any agreement or other document of any description shall be construed to give effect to amendments, supplements, modifications or any superseding agreement or document as then exist at the applicable time to which such construction applies.
- (c) Capitalized terms used in this Agreement, including the appendices hereto, shall have the meaning set forth in Article 1, unless otherwise specified.
- (d) Unless otherwise specified herein, references in the singular shall include references in the plural and vice versa, pronouns having masculine or feminine gender will be deemed to include the other, and words denoting natural persons shall include partnerships, firms, companies, corporations, joint ventures, trusts, associations, organizations or other entities (whether or not having a separate legal personality). Other grammatical forms of defined words or phrases have corresponding meanings.
- (e) The term “including” when used in this Agreement shall be by way of example only and shall not be considered in any way to be in limitation.
- (f) References to a particular article, section, subsection, paragraph, subparagraph, appendix or attachment shall, unless specified otherwise, be a reference to that article, section, subsection, paragraph, subparagraph, appendix or attachment in or to this Agreement.
- (g) Any reference in this Agreement to any natural person, Governmental Authority, corporation, partnership or other legal entity includes its permitted successors and assigns or to any natural person, Governmental Authority, corporation, partnership or other legal entity succeeding to its functions.
- (h) All references to dollars are to U.S. dollars.

ARTICLE TWO: EFFECTIVENESS OF AGREEMENT; CONDITIONS PRECEDENT

2.1 Effectiveness of Agreement Prior to CP Satisfaction Date. Commencing on the Execution Date until the CP Satisfaction Date, this Agreement shall be in full force and effect, enforceable and binding only to the extent required to give full effect to, and enforce, the rights and obligations of the Parties under Articles 1, 2, 5, 7, 8, 9, 10, 11, 12, and 13.

2.2 Obligations of the Parties. The Parties shall cooperate with each other to cause the Conditions Precedent to be satisfied as soon as reasonably practical.

- (a) Seller's Obligations. Prior to the CP Satisfaction Date, Seller shall (i) use commercially reasonable efforts to pursue satisfaction of the Conditions Precedent set forth in Sections 2.3(a), 2.3(c), and 2.3(d), (ii) use commercially reasonable efforts to pursue development of the Project in accordance with Section 3.9, (iii) comply with Section 3.9(b) achieving the applicable Milestones that have due dates occurring prior to the CP Satisfaction Date, in reporting completion of such Milestones, and delivering Remedial Action Plans in respect of missed Milestones as more fully described therein, (iv) deliver the Quarterly Progress Report in accordance with Section 3.9(a), and (v) otherwise comply with its obligations, covenants, representations, and warranties under Articles 7-13. Upon an Event of Default of Seller prior to the CP Satisfaction Date, Buyer may terminate this Agreement in which case Seller shall owe Buyer liquidated damages in the amount of the Development Period Security. Buyer may retain such Performance Assurance to pay such liquidated damages. Each Party agrees and acknowledges that (a) the actual damages that Buyer would incur due to an Event of Default of Seller prior to the CP Satisfaction Date would be difficult or impossible to predict with certainty, (b) the liquidated damages set forth in this section are a reasonable and appropriate approximation of such damages, and (c) the liquidated damages set forth in this section are the exclusive remedy for an Event of Default of Seller prior to the CP Satisfaction Date.

- (b) Buyer's Obligations. Prior to the CP Satisfaction Date, Buyer shall (i) use commercially reasonable efforts to pursue satisfaction of the Conditions Precedent set forth in Sections 2.3(a), and (ii) otherwise comply with its obligations, covenants, representations, and warranties under Articles 7-13. Upon an Event of Default of Buyer prior to the CP Satisfaction Date, Seller may terminate this Agreement in which case Buyer shall owe Seller liquidated damages in the amount of the Development Period Security. Each Party agrees and acknowledges that (a) the actual damages that Seller would incur due to an Event of Default of Buyer prior to the CP Satisfaction Date would be difficult or impossible to predict with certainty, (b) the liquidated damages set forth in this section are a reasonable and appropriate approximation of such damages, and (c) the liquidated damages set forth in this section are the exclusive remedy for an Event of Default of Buyer prior to the CP Satisfaction Date.

2.3 Conditions Precedent. Subject to Section 2.1, the effectiveness of the remainder of this Agreement is conditioned upon the satisfaction (or waiver by the Party described in Section 2.4) of all of the following conditions precedent ("Conditions Precedent") by the deadline dates

set forth below for each Condition Precedent without extension for Force Majeure or any other reason:

- (a) CPUC Approval. No later than July 31, 2011, Buyer shall have obtained CPUC Approval. Prior to this deadline, should the CPUC issue an order approving this Agreement with conditions or modifications that materially alter the commercial aspects of this Agreement, or rejecting this Agreement for the reasons set forth in such order, the Parties agree to use good faith efforts to renegotiate this Agreement (to the extent possible, consistent with the CPUC order while preserving the original intent of the Parties) and file the amended agreement with the CPUC seeking approval thereof. If, within sixty (60) days, no agreement is reached, either Party may terminate this Agreement effective upon delivery of Notice to the other Party, and neither Party shall have any further liability to the other Party under this Agreement.
- (b) Electric Interconnection. No later than the earlier of (i) the date that is thirty (30) days after the date Seller has provided a copy of its fully executed interconnection agreement to Buyer, or (ii) July 31, 2011, Buyer shall have agreed to and approved of (in its sole discretion) the deliverability of the Product (but such agreement to and approval of deliverability may only be withheld if the fully executed interconnection agreement includes deliverability limitations that result in an adverse impact on the Project's ability to provide Resource Adequacy), the in-service interconnection date (but such agreement to and approval of the in-service interconnection date may only be withheld if such date is later than the Guaranteed Commercial Operation Date), and the costs to be incurred by Buyer (but such agreement to and approval of costs to be incurred by Buyer may only be withheld if such costs exceed Eight Million Dollars) for any required transmission network upgrades (reliability or deliverability) reasonably necessary to enable the cost-effective and reliable delivery of Energy from the Project to Buyer's load as is consistent with FERC's then current orders and rulemakings.
- (c) Permits. No later than September 30, 2011, Seller shall have received the county Major Use Permit required for the construction and operation of the Project.
- (d) Financing. No later than September 30, 2011, Seller shall have obtained third party construction financing for the Project on terms reasonably acceptable to Seller.

2.4 Failure to Meet All Conditions Precedent.

- (a) Beneficiary Party.

- (i) Both of the Parties are the beneficiaries of the Conditions Precedent set forth in Section 2.3(a), and in order for a waiver of non-satisfaction of such Conditions Precedent to be effective, both of the Parties must waive (in their sole discretion) non-satisfaction by the deadline date therefor.
 - (ii) Buyer shall be the beneficiary of the Conditions Precedent set forth in Sections 2.3(b) and in order for a waiver of non-satisfaction of such Conditions Precedent to be effective, Buyer alone must waive (in its sole discretion) non-satisfaction by the deadline date therefor.
 - (iii) Seller shall be the beneficiary of the Conditions Precedent set forth in Sections 2.3(c)-(d) and in order for a waiver of non-satisfaction of such Conditions Precedent to be effective, Seller alone must waive (in its sole discretion) non-satisfaction by the deadline date therefor.
- (b) Termination.
- (i) If (A) any of the Conditions Precedent is not satisfied or waived in writing by the beneficiary Parties thereto on or before the applicable deadline date therefor, or (B) the CP Satisfaction Date has not occurred by September 30, 2011 without extension for Force Majeure or any other reason, then either of the Parties may terminate this Agreement with no further obligation to either Party (other than as set forth in Section 2.4(b)(ii) below and any other payment obligations which are accrued and payable at the time of termination) by delivery of Notice to the other Party within fifteen days after the applicable deadline date. If a Party has the right to terminate this Agreement pursuant to this Section 2.4, but fails to deliver Notice of termination within each fifteen day period after each deadline date, then such Party's termination right per this Section 2.4 for such deadline date shall be deemed waived in its entirety.
 - (ii) Upon a termination of this Agreement by Seller for any reason under Section 2.4 other than the failure of the Conditions Precedent set forth in Section 2.3(a) to be satisfied or waived by the beneficiary Parties thereto, Seller shall forfeit to Buyer an amount equal to the Development Period Security. Buyer may retain the Development Period Security to pay such amount.

2.5 Effectiveness of Agreement on and after CP Satisfaction Date. This Agreement shall be in full force and effect, enforceable and binding in all respects as of the CP Satisfaction Date until the conclusion of the Delivery Term or earlier termination pursuant to the terms of this Agreement; provided however, that this Agreement shall remain in effect until (i) the Parties

have fulfilled all obligations under this Agreement, including payment in full of amounts due for the Product delivered prior to the end of the Delivery Term, the Settlement Amount, indemnification payments or other damages (whether directly or indirectly such as through set-off or netting) and (ii) the undrawn portion of the Development Period Security, Construction Period Security, or Delivery Term Security, as applicable, is released and/or returned as applicable (if any is due). All indemnity rights shall survive the termination or expiration of this Agreement for the longer of twelve (12) months or the expiration of the statute of limitations period of the claim underlying the indemnity obligation.

ARTICLE THREE: OBLIGATIONS AND DELIVERIES

3.1 Transaction.

- (a) Product. The “Product” to be delivered and sold by Seller and received and purchased by Buyer under this Agreement is As-Available Delivered Energy, Capacity Attributes, and associated Green Attributes, and other ancillary products, services or attributes similar to the foregoing which are or can be produced by or associated with the Project (net of Station Service) in accordance with the terms hereof.
- (b) Transaction. Unless specifically excused by the terms of this Agreement during the Delivery Term, Seller shall sell and deliver, or cause to be delivered, and Buyer shall purchase and receive, or cause to be received, the Product at the Delivery Point, and Buyer shall pay Seller for the Product in accordance with the terms hereof. In no event shall Seller have the right to procure any element of the Product from sources other than the Project for sale or delivery to Buyer under this Agreement.
- (c) Delivery Term. The Parties agree that the period of Product delivery is twenty-five (25) Contract Years. As used herein, “Delivery Term” shall mean the period of Contract Years specified above beginning on the Commercial Operation Date and continuing until the end of the last Contract Year unless terminated earlier as provided by the terms of this Agreement.
- (d) Delivery Point. The Delivery Point shall be the point of interconnection of the Project to the CAISO Grid, as specified in the Project's interconnection agreement.
- (e) Contract Quantity, Guaranteed Energy Production, and GEP Liquidated Damages.
 - (i) Defined Terms.

“Annual Contract Quantity” means the quantity of Delivered Energy that Seller expects to be able to deliver to Buyer during each Contract Year of the

Delivery Term following the Commercial Operation Date, which quantity Seller expects to be 60,000MWh degraded at 1% per Contract Year (“Contract Quantity”).

“Bi-Annual Contract Quantity” means the quantity of Delivered Energy that Seller expects to be able to deliver to Buyer during each Performance Measurement Period of the Delivery Term following the Commercial Operation Date, which quantity is equal to the product of two times the then applicable Annual Contract Quantity.

“Default Energy Production” means, for any Performance Measurement Period, an amount of Energy, as measured in MWh, equal to fifty percent (50%) of the Bi-Annual Contract Quantity for such Performance Measurement Period.

“GEP Liquidated Damages” means the Replacement Price, which shall be no less than \$35.00 and no more than \$50.00.

“Guaranteed Energy Production” means, for any Performance Measurement Period, an amount of Energy, as measured in MWh, equal to seventy percent (70%) of the Bi-Annual Contract Quantity for such Performance Measurement Period.

“Performance Measurement Period” means any twenty-four (24) consecutive calendar months during the Delivery Term.

(ii) Performance Obligation. Throughout the Delivery Term, Seller shall be required to deliver to Buyer no less than the Guaranteed Energy Production in any Performance Measurement Period. Notwithstanding the excuses to performance set forth in the definition of the Product type (as such Product type is specified in Section 3.1(a)), Seller shall be excused from achieving the Guaranteed Energy Production and the Default Energy Production during any Performance Measurement Period only to the extent of any Force Majeure events, Buyer’s fault, negligence, or failure to perform, Dispatch Down Periods, or curtailment of delivery of Product from the Project resulting from economic curtailment where Buyer (as the Scheduling Coordinator) submits an economic bid in the applicable CAISO market that results in an otherwise available Product not being scheduled or awarded in such CAISO market, and, with respect to the Guaranteed Energy Production only, any Energy shortfall for which Seller has paid liquidated damages as required under Section 3.1(e)(iii). For purposes of determining whether Seller has achieved the Guaranteed Energy Production or Default Energy Production, Seller shall be deemed to have delivered to Buyer Energy equal to the sum of (A) Delivered Energy during such Performance Measurement Period, plus (B) the amount of Energy that Seller could reasonably have delivered to Buyer during such Performance Measurement Period but was prevented from delivering to Buyer by reason of any Force Majeure events, Buyer’s fault, negligence, or failure to perform, Dispatch Down Periods, or curtailment of delivery of Product from the Project resulting from economic curtailment where Buyer (as the Scheduling Coordinator) submits an economic bid in the applicable CAISO market that results in an otherwise available Product not being scheduled or awarded in such CAISO market. For purposes of determining whether Seller has achieved the Guaranteed Energy Production only, in addition to the amounts of Energy deemed delivered pursuant to the preceding sentence, Seller shall also be deemed to have delivered to Buyer Energy equal to the amount of Energy during

such Performance Measurement Period with respect to which Seller has paid liquidated damages as required under Section 3.1(e)(iii).

(iii) Liquidated Damages. If Seller fails to achieve the Guaranteed Energy Production but achieves the Default Energy Production in any Performance Measurement Period, Seller shall cure such failure by paying to Buyer liquidated damages in the amount of the product of the GEP Liquidated Damages times the amount of Energy that Seller is deficient in achieving the Guaranteed Energy Production. The invoice for such amount shall include a written statement explaining in reasonable detail the calculation of such amount. Each Party agrees and acknowledges that (x) the actual damages that Buyer would incur due to Seller's failure to achieve the Guaranteed Energy Production would be difficult or impossible to predict with certainty, (y) the liquidated damages set forth in this section are a reasonable and appropriate approximation of such damages, and (z) the liquidated damages set forth in this section are the exclusive remedy for Seller's failure to achieve the Guaranteed Energy Production; provided, however, that such liquidated damages shall not limit Buyer's remedies in respect of any other Event of Default, including the failure by Seller to pay such liquidated damages or the failure by Seller to achieve the Default Energy Production in any Performance Measurement Period.

- (f) Contract Capacity. The "Contract Capacity" is the full generation capacity of the Project net of all Station Service, which shall be no less than 25.5MW and no greater than 26MW. Throughout the Delivery Term, Seller shall sell and Schedule all Product associated with the Contract Capacity of the Project solely to Buyer, except in the case of an Event of Default of Buyer.
- (g) Project. All Product provided by Seller pursuant to this Agreement shall be supplied from the Project only. Other than maintenance, which may include repair or replacement of facilities or equipment, in accordance with Good Industry Practices, Seller shall not make any alteration or modification to the Project which results in a material change to the Contract Capacity of the Project without Buyer's prior written consent, which consent shall not be unreasonably withheld. The Project is further described in Exhibit A.
- (h) Performance Excuses.
 - (i) Seller Excuses. The performance of Seller to Schedule, deliver, and sell the Product shall be excused only for the reasons set forth in the definition of the Product type (as such Product type is specified in Section 3.1(a)). If Seller fails to Schedule, deliver, or sell all or part of the Product, and such failure is not excused as described above, then Seller shall pay Buyer, on the date payment would otherwise be due in respect of the month in which the failure occurred an amount for such Product deficiency equal to the positive difference, if any, obtained by subtracting (i) the product of the Energy Price times the TOD Factor for each period

of Product deficiency times the Product deficiency, from (ii) the Replacement Price times the Product deficiency. The invoice for such amount shall include a written statement explaining in reasonable detail the calculation of such amount.

(ii) Buyer Excuses. The performance of Buyer to Schedule, receive, and pay for the Product shall be excused only (A) during periods of Force Majeure, (B) by Seller's failure to perform or (C) during Dispatch Down Periods. If Buyer fails to Schedule, receive, or purchase all or part of the Product and such failure is not excused as described above, or, with respect to any curtailment of delivery of Product from the Project resulting from economic curtailment where Buyer (as the Scheduling Coordinator) submits an economic bid in the applicable CAISO market that results in an otherwise available Product not being scheduled or awarded in such CAISO market, then for each MWh of Energy that Seller would have delivered to Buyer, Buyer shall pay Seller, on the date payment would otherwise be due in respect of the month in which the failure occurred an amount for such Product deficiency equal to the positive difference, if any, obtained by subtracting (i) the Sales Price times the Product deficiency from (ii) the product of the Energy Price times the TOD Factor for each period of Product deficiency times the Product deficiency. The invoice for such amount shall include a written statement explaining in reasonable detail the calculation of such amount.

(i) Green Attributes. Seller hereby provides and conveys all Green Attributes associated with all electricity generation from the Project to Buyer as part of the Product being delivered. Seller represents and warrants that Seller holds the rights to all Green Attributes from the Project, and Seller agrees to convey and hereby conveys all such Green Attributes to Buyer as included in the delivery of the Product from the Project.

(j) Resource Adequacy.

(i) During the Delivery Term, Seller grants, pledges, assigns and otherwise commits to Buyer all of the Project's Contract Capacity, including Capacity Attributes, from the Project for Buyer to apply towards meeting its Resource Adequacy or successor program requirements, as the CPUC, CAISO or other regional entity may prescribe. Seller understands that the CPUC is currently in the process of developing requirements for Resource Adequacy and these requirements and the implementation thereof have not been finalized. Seller agrees that it shall take all commercially reasonable actions and execute any and all documents reasonably necessary to

enable Buyer to apply all of the Contract Capacity, including Capacity Attributes, to be committed by Seller to Buyer pursuant to this Agreement towards meeting the Resource Adequacy requirements of Buyer; provided, however, to the extent a change in Law occurs after the Execution Date that makes Seller's compliance with its obligations under this sentence more costly or burdensome, then subject to Section 4.5, Seller shall not be in breach of such obligations if Seller has used commercially reasonable efforts to comply with such change in Law as it pertains to such obligations, and if the Compliance Expenditure Cap has been exceeded, the Energy Price shall be reduced in accordance with Section 4.1(a).

- (ii) Seller agrees that the Project is subject to the terms of the Availability Standards. The Parties agree that any Availability Incentive Payments are for the benefit of the Seller and for Seller's account and that any Non-Availability Charges are the responsibility of the Seller and for Seller's account; provided, however, if the Non-Availability Charges net of the Availability Incentive Payments over the Contract Year exceed the Standard Capacity Product Compliance Expenditure Cap, then, after Seller has used commercially reasonable efforts to maximize the incentive payments and minimize the charges, Buyer has the right to either (A) agree in writing, on terms and conditions reasonably acceptable to Seller, to reimburse Seller for, or to pay directly 100% of such excess expenditures or (B) remove the Project from Buyer's Resource Adequacy supply plan. Furthermore, if Buyer does agree in writing to pay such expenditures or Buyer removes the Project from Buyer's Resource Adequacy supply plan, the Energy Price shall be reduced in accordance with Section 4.1(a).
- (k) Climate Registry. Seller shall register the Project with the Climate Registry as may be required by the CPUC pursuant to Decision 06-02-032 and any subsequent order, but in any event, prior to the first delivery of Test Energy.
- (l) WREGIS. Prior to the Initial Energy Delivery Date, Seller shall register the Project in the WREGIS, and take all other commercially reasonable actions necessary to ensure that the Energy and all Green Attributes produced from the Project are issued and tracked for purposes of satisfying the requirements of the California Renewable Portfolio Standard and transferred to Buyer, including payment of all fees required to register the facility in WREGIS, issue WREGIS certificates, and transfer such certificates to Buyer. Seller warrants that all necessary steps to allow the Renewable Energy Credits transferred

to Buyer to be tracked in WREGIS will be taken prior to the first delivery under the Agreement.

- (m) Prevailing Wage. To the extent applicable, Seller shall comply with the prevailing wage requirements of California Public Utilities Code Section 399.14, subdivision (h).

3.2 Transmission.

- (a) Seller's Transmission Service Obligations. During the Delivery Term, Seller shall arrange and be responsible for transmission service for delivery of the Product to and at the Delivery Point and bear all risks and costs associated with such transmission service, including, but not limited to, electric transmission losses and any transmission outages or curtailment, except as provided otherwise in this Agreement in respect of Dispatch Down Periods. Seller shall fulfill all contractual, metering and applicable interconnection requirements, including those set forth in Participating Transmission Owner's applicable tariffs, the CAISO Tariff and implementing CAISO standards and requirements, including, but not limited to, executing applicable interconnection agreements, Participating Generator Agreement and Meter Service Agreement prior to the Initial Energy Delivery Date so as to be able to deliver Energy to the CAISO Grid. Seller shall arrange for any interconnection agreement with the CAISO and such interconnection agreement is separate and not a part of this Agreement.
- (b) Buyer's Transmission Service Obligations. During the Delivery Term, Buyer shall arrange and be responsible for transmission service for delivery of the Product at and from the Delivery Point and bear all risks and costs associated with such transmission service, including, but not limited to, all Transmission Provider costs and charges, electric transmission losses, and any transmission outages or curtailment, except as provided otherwise in this Agreement in respect of Dispatch Down Periods.
- (c) Congestion Charges. Except with respect to congestion costs imbedded in the CAISO PNode price and associated with CAISO revenues that are otherwise allocated under this Agreement, (a) Seller shall be responsible for all costs of congestion for transmission of the Product up to the Delivery Point, and (b) Buyer shall be responsible for all costs of congestion for transmission of the Product at and from the Delivery Point. To the extent that Seller is reimbursed for or receives any refunds, credits, or benefits from the CAISO for congestion charges or losses in respect of transmission of the Product from the Delivery Point, whether due to differences between the locational marginal pricing at the Delivery Point and Buyer's load aggregation point or any other point downstream of the Delivery Point, congestion revenue rights

associated with any transmission path downstream of the Delivery Point, or any other hedging instruments associated with the transmission of the Product from the Delivery Point (collectively, any such refunds, credits or benefits are referred to as “Reductions”), then, at Buyer’s option, either (i) Seller shall transfer any such Reductions and their related rights to Buyer; or (ii) Buyer shall reduce payments due to Seller under this Agreement in amounts equal to the Reductions and Seller shall retain the Reductions.

3.3 Scheduling.

(a) EIRP Requirements. Seller shall be responsible for all CAISO forecasting fees and related charges associated with the Project becoming a Participating Intermittent Resource and participating in PIRP. Seller and Buyer shall comply with PIRP, and all additional protocols issued by the CAISO relating to Participating Intermittent Resources, including the PIRP, for the Delivery Term. Seller shall apply for certification of the Project as a Participating Intermittent Resource prior to the Initial Energy Delivery Date, and thereafter use commercially reasonable efforts to obtain such certification, including executing all necessary documents to become a Participating Intermittent Resource. Seller shall provide Buyer with a copy of the notice from the CAISO certifying the Project as a Participating Intermittent Resource as soon as practicable after Seller’s receipt of such notice of certification. In the event that PIRP or the CAISO Tariff and/or any protocols relating thereto are changed, amended, modified replaced or terminated, Seller and Buyer agree to comply with such revisions and, to the extent practical, to implement such revisions in a manner that maintains the relative economic positions of the parties as of the date of this Agreement; provided, however, to the extent a change in Law occurs after the Execution Date that makes Seller’s compliance with its obligations under this sentence more costly or burdensome, then subject to Section 4.5 Seller shall not be in breach of such obligations if Seller has used commercially reasonable efforts to comply with such change in Law as it pertains to such obligations.

(b) Scheduling Coordinator.

(i) Buyer as Scheduling Coordinator for the Project. Upon the Initial Energy Delivery Date, Buyer shall be the Scheduling Coordinator or designate a qualified third party to provide Scheduling Coordinator services with the CAISO for the Project for both the delivery and the receipt of the Product at the Delivery Point. At least thirty (30) days prior to the Initial Energy Delivery Date, Seller shall take all actions and execute and deliver to Buyer and the CAISO all documents necessary to authorize or designate Buyer as Seller’s Scheduling Coordinator for the Project effective as of Initial Energy Delivery Date. On and after the Initial Energy Delivery Date, Seller shall not authorize or designate any other party to act as Seller’s Scheduling Coordinator, nor shall Seller perform for its own benefit the duties of Scheduling Coordinator, and Seller shall not revoke Buyer’s authorization to act as Seller’s Scheduling Coordinator unless agreed to by Buyer. Buyer (as Seller’s SC) shall submit Schedules to the CAISO based on the final Schedule developed in accordance with this Agreement, the operating procedures developed by the Parties pursuant to Section 3.10, and the applicable CAISO Tariff, protocols and Scheduling practices for Product on a day-ahead, hour-ahead, or real time basis, as determined by Buyer. Buyer (as Seller’s SC) shall submit Schedules and any updates to such

Schedules to the CAISO based on the most current forecast of Scheduled Energy consistent with EIRP whenever EIRP is applicable, and consistent with Buyers' best estimate based on the information reasonably available to Buyer including Buyer's forecast whenever EIRP is not applicable. Buyer shall perform its duties as SC in good faith and in accordance with the CAISO Tariff and Good Industry Practice.

(ii) Notices. Buyer (as Seller's SC) may provide Seller with access to a web based system through which Seller shall submit to Buyer and the CAISO all notices and updates required under the CAISO Tariff regarding the Project's status, including, but not limited to, all outage requests, forced outages, forced outage reports, clearance requests, or must offer waiver forms. In accordance with Section 3.7 and this Section 3.2, Seller will cooperate with Buyer to provide such notices and updates. If the web based system is not available, Seller shall promptly submit such information to Buyer and the CAISO (in order of preference) telephonically, by electronic mail, or facsimile transmission to the personnel designated to receive such information.

(iii) CAISO Costs and Revenues. Except as otherwise set forth below and elsewhere in this Agreement, Buyer (as Seller's SC) shall be responsible for all CAISO costs (including penalties and other charges) and shall be entitled to all CAISO revenues (including credits and other payments) as the Scheduling Coordinator for the Project, including revenues associated with CAISO dispatches, bid cost recovery, inter-SC trade credits, or other credits in respect of the Product Scheduled or delivered from the Project. Seller shall be responsible for all CAISO charges or penalties net of credits and payments, in each case, resulting from the Seller not notifying the CAISO and Buyer (as Seller's SC) of outages or other unavailability of Project capacity in a timely manner (in accordance with the CAISO Tariff and as set forth in Section 3.7), including without limitation uninstructed deviation penalties resulting therefrom, or any other failure by Seller to abide by the CAISO Tariff. In addition, if during the Delivery Term, the CAISO implements or has implemented any sanction or penalty related to scheduling, outage reporting, or generator operation, and any such sanctions or penalties are imposed upon the Project or to Buyer as Scheduling Coordinator due to the actions or inactions of Seller, the cost of the sanctions or penalties shall be the Seller's responsibility.

(iv) CAISO Settlements. Buyer (as Seller's SC) shall be responsible for all settlement functions with the CAISO related to the Project. Buyer shall render a separate invoice, including CAISO settlement details specific to the Project, to Seller for any CAISO charges or penalties ("CAISO Charges Invoice") for which Seller is responsible under this Agreement. CAISO Charges Invoices shall be rendered after final settlement information becomes available from the CAISO (approximately 90 days after each month in the Delivery Term) that identifies any CAISO charges. Notwithstanding the foregoing, Seller acknowledges that the CAISO will issue additional invoices reflecting CAISO adjustments to such CAISO charges. Seller shall pay the amount of CAISO Charges Invoices within ten Business Days of Seller's receipt of the CAISO Charges Invoice. If Seller fails to pay such CAISO Charges Invoice within that period, Buyer may net or offset any amounts owing to it for these CAISO Charges Invoices against any future amounts it may owe to Seller under this Agreement. The obligations under this section with respect to payment of CAISO Charges Invoices shall survive the expiration or termination of this Agreement.

(v) Dispute Costs. Buyer (as Seller's SC) shall review and validate CAISO settlements data related to the Project using the same methods as Buyer uses for its own generating facilities in the CAISO. If Buyer identifies an error or dispute, or Seller informs Buyer of an error or dispute, then Buyer (as Seller's SC) shall file with the CAISO and prosecute disputes related to CAISO settlements in respect of the Project. Seller agrees to pay Buyer's costs and expenses (including reasonable attorneys' fees, including reasonably allocated costs of in-house counsel of the Buyer) associated with its involvement with such CAISO disputes.

(vi) Terminating Buyer's Designation as Scheduling Coordinator. At least thirty (30) days prior to expiration of this Agreement or as soon as reasonably practicable upon an earlier termination of this Agreement, the Parties will take all actions necessary to terminate the designation of Buyer as Scheduling Coordinator for the Project as of 11:59 p.m. on such expiration date.

(vii) Master Data File and Resource Data Template. Seller shall provide the data to the CAISO (and to Buyer) that is required for the CAISO's Master Data File and Resource Data Template (or successor data systems) for this Project consistent with this Agreement. Neither Party shall change such data without the other Party's prior written consent.

(viii) NERC Reliability Standards. Buyer, as Seller's SC, shall cooperate reasonably with Seller to the extent necessary to enable Seller to comply, and for Seller to demonstrate Seller's compliance, with NERC reliability standards.

(c) Annual Forecast of Delivery Schedules. No later than forty-five (45) days before (A) the first day of the first Contract Year of the Delivery Term and (B) the beginning of each calendar year for every subsequent Contract Year during the Delivery Term, Seller shall provide a non-binding forecast of each month's average-day Scheduled Energy, by hour, for the following calendar year.

(d) Monthly Forecast of Delivery Schedules. Ten (10) Business Days before the beginning of each month during the Delivery Term, Seller shall provide a non-binding forecast of each day's average Scheduled Energy, by hour, for the following month ("Monthly Delivery Forecast").

(e) Daily Delivery Schedules. By 5:30 AM Pacific Prevailing Time on the Business Day immediately preceding the date of delivery, Seller shall provide Buyer with a non-binding forecast of the Scheduled Energy for each hour of the immediately succeeding day ("Day-Ahead Schedule"). A Day-Ahead Schedule provided in a day prior to any non-Business Day(s) shall include Schedules for the immediate day, each succeeding non-Business Day and the next Business Day. Each Day-Ahead Schedule shall clearly identify, for each hour, Seller's best estimate of all amounts of Energy to be delivered and sold to Buyer pursuant to this Agreement. Seller shall use reasonable efforts to deliver Energy in accordance with its Day-Ahead Schedule, provided that such reasonable efforts shall not include any obligation of Seller to reduce the output of the Project. Seller shall accurately reflect on such Schedule the expected generation of the Project, subject to the applicable CAISO Tariff, and Seller may not change such Schedule past the deadlines provided in this section except in the event of a Forced Outage or Schedule change imposed by Buyer or the CAISO, in which case Seller shall promptly

provide Buyer with a copy of any and all updates to such Schedule indicating changes from the then-current Schedule. These notices and changes to the Schedules shall be sent to Buyer's on-duty Scheduling Coordinator. If Seller fails to provide Buyer with a Day-Ahead Schedule as required herein, then for such unscheduled delivery period only Buyer shall rely on the delivery Schedule provided in the Monthly Delivery Forecast or Buyer's best estimate based on information reasonably available to Buyer and Seller shall be liable for Scheduling and delivery based on such Monthly Delivery Forecast or Buyer's best estimate.

(f) Hourly Delivery Schedules. Notwithstanding anything to the contrary herein, in the event Seller makes a change to its Schedule on the actual date of delivery for any reason including Forced Outages (other than a scheduling change imposed by Buyer or CAISO) which results in a change to its deliveries (whether in part or in whole), Seller shall notify Buyer within fifteen (15) minutes after making such change in Schedule by calling Buyer's on-duty Scheduling Coordinator. Seller shall notify Buyer and the CAISO of Forced Outages in accordance with Section 3.7. Seller shall keep Buyer informed of any developments that will affect either the duration of the outage or the availability of the Project during or after the end of the outage.

3.4 Dispatch Down/Curtailment. Seller shall reduce delivery amounts as directed by the CAISO, the Participating Transmission Owner, or a Transmission Provider during any Dispatch Down Period.

3.5 Standards of Care.

- (a) General Operation. Seller shall comply with all applicable requirements of Law, the CAISO, NERC and WECC relating to the Project (including those related to construction, ownership and/or operation of the Project).
- (b) CAISO and WECC Standards. Each Party shall perform all generation, scheduling and transmission services in compliance with all applicable (i) operating policies, criteria, rules, guidelines, tariffs and protocols of the CAISO, (ii) WECC scheduling practices and (iii) Good Industry Practices.
- (c) Reliability Standard. Seller agrees to abide by all (i) NERC, WECC and CAISO reliability requirements, including all such reliability requirements for generator owners and generator operators, and, if applicable, CPUC General Order No.167, "Enforcement of Maintenance and Operation Standards for Electrical Generating Facilities," and (ii) all applicable requirements regarding interconnection of the Project, including the requirements of the interconnected Transmission Provider. Seller shall enter into and comply with the WECC Reliability Management System (Generator) Agreement, or successor agreement, as of the Initial Energy Delivery Date, and throughout the Delivery Term.

3.6 Metering.

- (a) CAISO Revenue Meter. All output from the Project per the terms of this Agreement must be delivered through a single CAISO revenue meter and that meter must be dedicated exclusively to the Project described herein. All Product purchased under this Agreement must be measured by the Project's CAISO revenue meter to be eligible for payment under this Agreement. Seller shall bear all costs relating to all metering equipment reasonably necessary to accommodate the Project. In addition, Seller hereby agrees to provide all meter data to Buyer in a form acceptable to Buyer and consents to Buyer obtaining from the CAISO the CAISO meter data applicable to the Project and all inspection, testing and calibration data and reports. Seller shall grant Buyer read-only rights to retrieve the meter reads from the CAISO meter reporting website and/or directly from the CAISO meter(s) at the Project site. If the CAISO makes any adjustment to any CAISO meter data for a given time period, Seller agrees that it shall submit revised monthly invoices, if necessary, pursuant to Section 6.2, covering the entire applicable time period in order to conform fully such adjustments to the meter data. Seller shall submit any such revised invoice no later than thirty (30) days from the date on which the CAISO provides to Seller such binding adjustment to the meter data.
- (i) Testing and Calibration. Seller shall perform or cause to be performed, at its expense, annual testing and calibration of the electric meters in accordance with Good Industry Practice and the CAISO Tariff. Seller shall give Buyer reasonable advance notice of any inspection, testing or calibration of the electric meters. Buyer shall have the right to have a representative or designee present at such inspection, test or calibration of the electric meters. Buyer shall have the right to require, at Buyer's expense, except as required below, a test of any of the electric meters not more often than two (2) times every twelve (12) months.
- (ii) Inaccurate Meters. If any of the electric meters is deemed to be inaccurate under the Meter Service Agreement, deliveries shall be measured by reference to Seller's check-meters, if any are installed and registering accurately, or the meter readings for the period of inaccuracy shall be adjusted as far as can be reasonably ascertained by Seller from the best available data, subject to review and approval by Buyer, such approval not to be unreasonably withheld. If the period of the inaccuracy cannot be ascertained reasonably, any such adjustment shall be for a period equal to one-half of the time elapsed since the preceding test by applying the percentage of inaccuracy so found. Seller shall promptly cause such electric meters to be corrected and, where

such inaccuracy was determined pursuant to a test required by Buyer, Seller shall bear the expense of any such test.

- (iii) Delivered MWh Adjustments. In the event that, due to correction for inaccurate electric meters deemed to be inaccurate under the Meter Service Agreement, the Delivered Energy is increased or decreased, the revised Delivered Energy shall be used for purposes of calculating payments. If any of such amounts for any period have already been calculated using the previous amount of Delivered Energy, they shall be recalculated using the revised amount of Delivered Energy. If the recalculation changes the amount payable for the period in question, revised payments shall be made by Buyer or Seller, as applicable, in accordance with Section 6.2.

- (b) Real Time Telemetry. Seller shall install, activate and maintain metering, communication and telemetry equipment for the Project in a centralized system to which Buyer shall have real time access. Seller shall link its system to Buyer via an approved Buyer communication network, utilizing existing industry standard network protocol, as reasonably approved by Buyer. Seller shall correct any problems with such equipment as soon as practicable.

- (c) Meteorological Station. Seller, at its own expense, shall install and maintain one (1) stand-alone meteorological station at the Project to monitor and report weather data to both the CAISO and Buyer's weather station data collection system. Each station shall be equipped with instruments and equipment that meet the specifications of EIRP and shall measure, collect, record, format, and communicate the data required under EIRP. Seller shall submit to Buyer for review its technical specifications for the meteorological station along with a site plan showing the location of the station within the Project. Seller shall correct any problems with such equipment as soon as practicable.

3.7 Outage Notification.

- (a) Planned Outages. Seller shall schedule Planned Outages for the Project in accordance with Good Industry Practices and with the prior written consent of Buyer, which consent may not be unreasonably withheld or conditioned. The Parties acknowledge that in all circumstances, Good Industry Practices shall dictate when Planned Outages should occur. Seller shall notify Buyer of its proposed Planned Outage schedule for the Project for the following calendar year by submitting a written Planned Outage schedule no later than October 1st of each year during the Delivery Term. The Planned Outage schedule is subject to Buyer's approval, which approval may not be unreasonably withheld or conditioned. Buyer shall promptly respond with its approval or with

reasonable modifications to the Planned Outage schedule and Seller shall use best efforts in accordance with Good Industry Practices to accommodate Buyer's requested modifications. Notwithstanding the submission of the Planned Outage schedule described above, Seller shall also submit a completed Outage Notification Form to Buyer no later than fourteen (14) days prior to each Planned Outage and all appropriate outage information or requests to the CAISO in accordance with the CAISO Tariff. Seller shall contact Buyer with any requested changes to the Planned Outage schedule if Seller believes the Project must be shut down to conduct maintenance that cannot be delayed until the next scheduled Planned Outage consistent with Good Industry Practices. Seller shall not change its Planned Outage schedule without Buyer's approval, not to be unreasonably withheld or conditioned. Seller shall use best efforts in accordance with Good Industry Practices not to schedule Planned Outages during the months of July, August, September and October. At Buyer's request, Seller shall use commercially reasonable efforts to reschedule Planned Outage so that it may deliver Product during CAISO declared or threatened emergency periods. Seller shall not substitute Energy from any other source for the output of the Project during a Planned Outage.

- (b) Forced Outages. Within fifteen minutes after notifying the CAISO of any Forced Outage, Seller shall submit a completed Outage Notification Form to the Buyer in accordance with the instructions shown on the form, and Seller shall submit outage information to the CAISO in accordance with the CAISO Tariff and Section 3.3(b)(ii) above. Seller shall not substitute Energy from any other source for the output of the Project during a Forced Outage.
- (c) Coordination with CAISO. Seller shall be responsible in accordance with Section 3.3(b)(ii) for all outage coordination communications with the CAISO. Buyer shall cooperate with Seller in arranging and coordinating all Project outages with the CAISO.

3.8 Operations Logs and Access Rights.

- (a) Operations Logs. Seller shall maintain a complete and accurate log of all material operations and maintenance information on a daily basis. Such log shall include, but not be limited to, information on power production, fuel consumption, efficiency, availability, maintenance performed, outages, results of inspections, manufacturer recommended services, replacements, electrical characteristics of the generators, control settings or adjustments of equipment and protective devices. Seller shall maintain this information for at least two (2) years and shall provide this information electronically to Buyer within fourteen (14) days of Buyer's request.

- (b) Access Rights. Buyer, its authorized agents, employees and inspectors shall have the right of ingress to and egress from the Project during normal business hours upon reasonable advance Notice and for any purposes reasonably connected with this Agreement.

3.9 New Generation Facility.

- (a) Project Development. Seller, at no cost to Buyer, shall:
 - (i) Design and construct the Project.
 - (ii) Perform all studies, pay all required fees, obtain all necessary approvals and execute all necessary agreements with the CAISO and the Participating Transmission Owner for the Interconnection Facilities to Schedule and deliver the Product.
 - (iii) Acquire all Governmental Approvals and other approvals necessary for the construction, operation, and maintenance of the Project.
 - (iv) Complete all environmental impact studies necessary for the construction, operation, and maintenance of the Project, including all environmental analysis required under the California Environmental Quality Act for the Project and related interconnection facilities.
 - (v) At Buyer's request, provide to Buyer Seller's electrical specifications and electrical design drawings pertaining to the Project for informational purposes only.
 - (vi) Within fifteen (15) days after the close of each calendar quarter following the Execution Date until the Commercial Operation Date, provide to Buyer a Quarterly Progress Report and agree to regularly scheduled meetings between representatives of Buyer and Seller to review such reports and discuss Seller's construction progress. The Quarterly Progress Report shall identify the Milestones and indicate whether Seller has met or is on target to meet such Milestones.
 - (vii) Provide access to Buyer, its authorized agents, employees and inspectors for purpose of inspecting the Project's construction site or on-site Seller data and information pertaining to the Project during normal business hours upon reasonable advance Notice.
- (b) Construction Milestones.
 - (i) The Parties agree time is of the essence in regards to this Agreement. As such, the Parties also agree that certain milestones

for the construction of the Project as set forth in the Milestone schedule attached hereto as Exhibit B (“Milestones”) must be achieved in a timely fashion or Buyer may suffer damages.

- (ii) Within seven (7) days after completion of each Milestone, Seller shall provide Buyer with Notice along with accompanying documentation (including reasonably redacted copies of applicable agreements, Governmental Approvals, and certificates) to reasonably demonstrate the achievement of such Milestone. If Seller misses the deadline date for three (3) or more Milestones or misses the deadline date for any one Milestone by more than ninety (90) days, Seller shall submit to Buyer, within ten (10) Business Days of such missed Milestone completion date, a remedial action plan (“Remedial Action Plan”) that describes in detail a reasonable course of action and plan (including accelerating the work, for example, by using additional shifts, overtime, additional crews or resequencing of the work, as applicable) to achieve the missed Milestones and all subsequent Milestones no later than the end of the Project Cure Period; provided, that delivery of any Remedial Action Plan shall not relieve Seller of its obligation to meet any subsequent Milestones and the Guaranteed Commercial Operation Date.

(c) Daily Delay Damages.

- (i) COD. Seller shall cause the Project to achieve the Commercial Operation Date by the Guaranteed Commercial Operation Date; provided, however, that the Commercial Operation Date shall not occur more than one hundred eighty (180) days prior to the Guaranteed Commercial Operation Date. If the Commercial Operation Date occurs after the Guaranteed Commercial Operation Date, Seller shall pay to Buyer liquidated damages equal to Daily Delay Damages for each day or portion of a day that Commercial Operation occurs after the Guaranteed Commercial Operation Date for up to a total of one hundred and eighty (180) calendar days (“Project Cure Period”). In addition, Seller shall submit a Remedial Action Plan within ten (10) days after the Guaranteed Commercial Operation Date if the Project has not then achieved Commercial Operation. Each Party agrees and acknowledges that (a) the actual damages that Buyer would incur due to a delay in achieving Commercial Operation on or before the Guaranteed Commercial Operation Date would be difficult or impossible to predict with certainty, (b) the Daily Delay Damages set forth in this section are a reasonable and appropriate approximation of such damages, and (c) the Daily Delay Damages set forth in this section are the exclusive remedy for Seller’s delay in achieving Commercial Operation by the

Guaranteed Commercial Operation Date but shall not otherwise act to limit any of Buyer's rights or remedies arising from any other Event of Default by Seller, including, without limitation, the failure by Seller to achieve Commercial Operation altogether.

- (ii) Extensions. The Guaranteed Commercial Operation Date and the deadline dates for the Milestones impacted by the circumstances below shall be extended on a day for day basis without imposition of any Daily Delay Damages to the extent Seller is actually and demonstrably delayed in its critical path to achieving Commercial Operation by the Guaranteed Commercial Operation Date:
 - (A) for up to one hundred and eighty (180) calendar days (or, seven hundred and twenty (720) calendar days if a Force Majeure event causes catastrophic damages to the Site or involves the failure of a long lead time major component of the Project) in the aggregate if such delay is a result of Force Majeure, and any such delay in excess of this period shall be subject to Daily Delay Damages pursuant to Section 3.9(c)(i); and
 - (B) for up to three hundred and sixty-five (365) calendar days in the aggregate if such delay is solely a result of the failure of the CAISO or the Participating Transmission Owner to achieve the in-service interconnection date for the Project's Interconnection Facilities by July 31, 2012, but only to the extent such failure is not the result of the fault or negligence of the Seller, and any such delay in excess of this period shall be subject to Daily Delay Damages pursuant to Section 3.9(c)(i). Each of Seller and Buyer acknowledges and agrees that nothing in this Agreement is intended to abrogate, amend or modify the terms of any other agreement between Seller and Buyer, including any electric interconnection agreement. Except as may be set forth in such electrical interconnection agreement, Buyer has made and makes no, and Seller is not relying on any, representations or warranties of any kind or nature, express or implied, with respect to the electrical interconnection, including, but not limited to, any representations or warranties concerning the costs, construction schedule, or permitting of, or any other matter related to, the electric interconnection for the Project. Seller's sole and exclusive remedy against Buyer under this Agreement for any delay by Buyer in completing any Interconnection Facilities is an extension of the Guaranteed Commercial Operation Date in accordance with this Section 3.9(c)(ii).
 - (iii) Notwithstanding the foregoing, the aggregate extension of the Guaranteed Commercial Operation Date permitted under Section 3.9(c)(ii) for all reasons shall extend the Guaranteed Commercial Operate Date to no later than December 31, 2014, and any such delays in excess of this period shall be subject to Daily Delay Damages pursuant to Section 3.9(c)(i).

- (iv) Mutual Termination Right. Either party has the right to terminate this Agreement if the delay in Section 3.9(c)(ii)(B) exceeds three hundred and sixty-five (365) calendar days, effective upon receipt of Notice. If Seller elects to terminate this Agreement under this Section 3.9(c)(iv), Buyer shall be entitled to retain the Construction Period Security as the Termination Payment. If Buyer elects to terminate this Agreement, Buyer shall have no further obligations or liabilities to Seller under this Agreement.

3.10 Operating Procedures. No later than forty-five (45) days before the Commercial Operation Date, and from time to time as reasonably determined to be necessary by the Parties, the Parties shall meet to address how each Party will perform its respective obligations under this Agreement, including, but not limited to: (1) the method of day-to-day communications; (2) key personnel lists for each Party; (3) procedures for Forced Outage and Planned Outage reporting; (4) procedures for delivery forecasting; (5) procedures for record keeping; (6) Scheduling procedures; and (7) invoicing and payment procedures; provided, that the failure to agree on these operating procedures will not relieve the Parties of their respective obligations under this Agreement, and any failure to agree shall be resolved in accordance with the dispute resolution procedures in Article 12.

ARTICLE FOUR: COMPENSATION; MONTHLY PAYMENTS; COMPLIANCE EXPENDITURE CAPS

4.1 Energy Payment.

- (a) Energy Price. The price for each MWh of Delivered Energy in each Contract Year shall be \$143.00, provided that the price shall be reduced to \$142.25 for each MWh of Delivered Energy in each partial or full month that is delivered after the Standard Capacity Product Compliance Expenditure Cap or the Compliance Expenditure Cap has been exceeded with respect to such Contract Year or the Term, as applicable, or during any period in which the Project has been removed from Buyer’s Resource Adequacy supply plan because the Standard Capacity Product Compliance Expenditure Cap has been exceeded (“Energy Price”).
- (b) TOD Factors and TOD Periods. In accordance with all other terms of this Article 4, the Energy Price shall be adjusted by the following Time of Delivery Factors (“TOD Factors”) for each of the specified Time of Delivery Periods listed in the first column (“TOD Periods”) in which Energy is delivered:

	Summer July 1 – October 31	Winter November 1 – June 30
On-Peak	Weekdays 11am – 7pm TOD Factor = 1.6411	Weekdays 1pm - 9pm TOD Factor = 1.1916

Semi-Peak	Weekdays 6am – 11am; Weekdays 7pm - 10pm TOD Factor = 1.0400	Weekdays 6am – 1pm; Weekdays 9pm – 10pm TOD Factor = 1.0790
Off-Peak*	All other hours TOD Factor = 0.8833	All other hours TOD Factor = 0.7928
*All hours during NERC holidays are off-peak.		

- (c) Monthly Energy Payment. For each month, Buyer shall pay Seller for the Product an amount equal to the sum for each hour in the month of the product of the Energy Price times the TOD Factor for the applicable TOD Period times the Delivered Energy in each hour (“Monthly Energy Payment”).

$$\text{Monthly Energy Payment} = \sum \text{Energy Price} \times \text{TOD Factor} \times \text{Delivered Energy}$$

4.2 Imbalance Energy. Buyer and Seller recognize that from time to time the amount of Delivered Energy will deviate from the amount of Scheduled Energy. When Delivered Energy minus Scheduled Energy is a positive amount, it shall be considered “Positive Imbalance Energy;” when Delivered Energy minus Scheduled Energy is a negative amount, the absolute (i.e., positive) value of that amount shall be considered the “Negative Imbalance Energy.” Buyer and Seller shall cooperate to minimize charges and imbalances associated with Imbalance Energy to the extent possible. Seller shall promptly notify Buyer as soon as possible of any material imbalance that is occurring or has occurred. Such notification shall not alter Seller’s responsibilities for payment for such charges to the extent allocated to Seller in accordance with the terms of this Agreement. Buyer shall receive all Green Attributes for the Positive Imbalance Energy in all settlement intervals regardless as to whether it was sold into the CAISO.

4.3 Additional Compensation. To the extent not otherwise provided for in this Agreement, in the event that Seller is compensated by a third party for any Product produced by the Project, including, but not limited to, compensation for Resource Adequacy or Green Attributes, Seller shall remit all such compensation directly to Buyer; provided that for avoidance of doubt, nothing herein precludes Seller from retaining credits related to transmission upgrades funded by Seller.

4.4 Test Energy. Prior to Commercial Operation and Seller obtaining EIRP certification for the Project, Buyer shall pay Seller an amount equal to the sum for each hour of the product of 75% of the Energy Price in Contract Year 1 multiplied by the TOD Factor multiplied by the Test Energy delivered by Seller and received by Buyer in each hour.

4.5 Expenditures Exceeding Compliance Expenditure Cap:- For purposes of Section 3.1(j)(i), Section 3.3(a), and Section 10.2, the term “commercially reasonable efforts” shall not require Seller to incur additional out-of-pocket expenditures in the aggregate in excess of the Compliance Expenditure Cap in any individual Contract Year, or over the term of the Agreement, as applicable, in complying with the changes in Law described in such sections unless Buyer has agreed in writing, on terms and conditions reasonably acceptable to Seller, to reimburse Seller for or to pay directly such excess expenditures (“Buyer Fronted Expenses”). To the extent Seller has incurred expenses that are subject to the Compliance Expenditure Cap each

subsequent Contract Year in a net amount (after netting out Buyer Fronted Expenses in such subsequent Contract Year) that is less than the Compliance Expenditure Cap, Seller shall reimburse Buyer for all Buyer Fronted Expenses with interest at Buyer's then weighted average cost of capital. Such reimbursement by Seller to Buyer shall be considered an expense that is also subject to the Compliance Expenditure Cap for each such subsequent Contract Year. Seller shall have no continuing obligation to reimburse Buyer for any such Buyer Fronted Expenses that have not been fully reimbursed by the end of the final Contract Year; provided, however, the foregoing shall not limit Buyer's rights to reimbursement of such Buyer Fronted Expenses with interest after an early termination of this Agreement upon an Event of Default where Seller is the Defaulting Party or Force Majeure event where Seller is the claiming Party. The Parties shall cooperate throughout each Contract Year to promptly address, account for, and inform each other of any expenses that are subject to the Compliance Expenditure Cap. Within thirty (30) days after the end of each Contract Year, Seller shall prepare an invoice detailing the expenses that are subject to the Compliance Expenditure Cap, the Buyer Fronted Expenses and interest thereon, and any payments or reimbursements owed to either Party in respect thereof and send Notice of the same to Buyer. Within thirty (30) days after such Notice, each Party shall pay or reimburse the other Party to the extent of any amounts owed.

ARTICLE FIVE: EVENTS OF DEFAULT; FORCE MAJEURE

5.1 Events of Default. An "Event of Default" shall mean,

- (a) with respect to a Party that is subject to the Event of Default the occurrence of any of the following:
 - (i) the failure by such Party to make, when due, any payment required pursuant to this Agreement and such failure is not remedied within five (5) Business Days after Notice thereof;
 - (ii) any representation or warranty made by such Party herein is false or misleading in any material respect when made or when deemed made or repeated, and such default is not remedied within thirty (30) days after Notice thereof;
 - (iii) the failure by such Party to perform any material covenant or obligation set forth in this Agreement (except to the extent constituting a separate Event of Default, and except for such Party's obligations to Schedule, deliver, or receive the Product, the exclusive remedy for which is provided in Section 3.1(h)) and such failure is not remedied within thirty (30) days after Notice thereof;
 - (iv) such Party becomes Bankrupt;
 - (v) such Party assigns this Agreement or any of its rights hereunder other than in compliance with Section 13.2; or

- (vi) such Party consolidates or amalgamates with, or merges with or into, or transfers all or substantially all of its assets to, another entity and, at the time of such consolidation, amalgamation, merger or transfer, the resulting, surviving or transferee entity fails to assume all the obligations of such Party under this Agreement to which it or its predecessor was a party by operation of Law or pursuant to an agreement reasonably satisfactory to the other Party.
- (b) with respect to Seller as the Defaulting Party, the occurrence of any of the following:
- (i) if at any time, Seller delivers or attempts to deliver to the Delivery Point for sale under this Agreement Energy that was not generated by the Project;
 - (ii) the failure by Seller to achieve the Commercial Operation Date no later than the end of the Project Cure Period;
 - (iii) the failure by Seller to achieve the Default Energy Production requirement during any Performance Measurement Period as set forth in Section 3.1(e) of this Agreement; or
 - (iv) [intentionally omitted]
 - (v) the failure by Seller to deliver a Remedial Action Plan that reasonably demonstrates in detail how Seller will achieve the Commercial Operation Date within the Project Cure Period, if such failure is not remedied within ten (10) days after Notice;
 - (vi) failure by Seller to satisfy the collateral requirements pursuant to Sections 8.3, 8.4, or 8.5 of this Agreement, if such failure is not remedied within five (5) Business Days after Notice;
 - (vii) with respect to any Guaranty provided for the benefit of Buyer, the failure by Seller to provide for the benefit of Buyer either (1) cash, (2) a replacement Guaranty from a different Guarantor meeting the criteria set forth in the definition of Guarantor, or (3) a replacement Letter of Credit from an issuer meeting the criteria set forth in the definition of Letter of Credit, in each case, in the amount required hereunder within five (5) Business Days after Seller receives Notice of the occurrence of any of the following events:
 - (A) if any representation or warranty made by the Guarantor in connection with this Agreement is false or misleading in any material respect when made or when deemed made or repeated, and such default is not remedied within thirty (30) days after Notice thereof;

- (B) the failure of the Guarantor to make any payment required or to perform any other material covenant or obligation in any Guaranty;
- (C) the Guarantor becomes Bankrupt;
- (D) the Guarantor shall fail to meet the criteria for an acceptable Guarantor as set forth in the definition of Guarantor;
- (E) the failure of the Guaranty to be in full force and effect (other than in accordance with its terms) prior to the indefeasible satisfaction of all obligations of Seller hereunder; or
- (F) the Guarantor shall repudiate, disaffirm, disclaim, or reject, in whole or in part, or challenge the validity of any Guaranty; or
 - (viii) with respect to any outstanding Letter of Credit provided for the benefit of Buyer, the failure by Seller to provide for the benefit of Buyer either (1) cash, or (2) a substitute Letter of Credit from a different issuer meeting the criteria set forth in the definition of Letter of Credit, in each case, in the amount required hereunder within five (5) Business Days after Seller receives Notice of the occurrence of any of the following events:
 - (A) the issuer of the outstanding Letter of Credit shall fail to maintain a Credit Rating of at least "A-" by S&P or "A3" by Moody's;
 - (B) the issuer of such Letter of Credit becomes Bankrupt;
 - (C) the issuer of the outstanding Letter of Credit shall fail to comply with or perform its obligations under such Letter of Credit and such failure shall be continuing after the lapse of any applicable grace period permitted under such Letter of Credit;
 - (D) the issuer of the outstanding Letter of Credit shall fail to honor a properly documented request to draw on such Letter of Credit;
 - (E) the issuer of the outstanding Letter of Credit shall disaffirm, disclaim, repudiate or reject, in whole or in part, or challenge the validity of, such Letter of Credit; or
 - (F) Seller shall fail to renew or cause the renewal of each outstanding Letter of Credit on a timely basis as provided in the relevant Letter of Credit and as provided in accordance with this Agreement, and in no event less than thirty (30) days prior to the expiration of the outstanding Letter of Credit.

5.2 Remedies; Declaration of Early Termination Date. If an Event of Default with respect to a Defaulting Party shall have occurred and be continuing, the other Party ("Non-Defaulting Party") shall have the right (a) to send Notice, designating a day, no earlier than the

day such Notice is deemed to be received and no later than twenty (20) days after such Notice is deemed to be received, as an early termination date of this Agreement (“Early Termination Date”) that terminates this Agreement and ends the Delivery Term effective as of the Early Termination Date, to accelerate all amounts owing between the Parties, and to collect liquidated damages calculated in accordance with Section 5.3 below (“Termination Payment”); (b) to withhold any payments due to the Defaulting Party under this Agreement; (c) to suspend performance; and (d) to exercise any other right or remedy available at law or in equity, including specific performance or injunctive relief, except to the extent such remedies are expressly limited under this Agreement.

5.3 Termination Payment. The Termination Payment for a Terminated Transaction shall be the aggregate of all Settlement Amounts plus any or all other amounts due to the Non-Defaulting Party netted into a single amount. Except in the case of a termination of this Agreement by the Non-Defaulting Party solely as a result of an Event of Default by the Defaulting Party under Section 5.1(a)(iv) [Bankruptcy], if the Non-Defaulting Party’s aggregate Gains exceed its aggregate Losses and Costs, if any, resulting from the termination of this Agreement, the Termination Payment shall be zero. The Non-Defaulting Party shall calculate, in a commercially reasonable manner, a Settlement Amount for the Terminated Transaction as of the Early Termination Date. Third parties supplying information for purposes of the calculation of Gains or Losses may include, without limitation, dealers in the relevant markets, end-users of the relevant product, information vendors and other sources of market information. The Settlement Amount shall not include consequential, incidental, punitive, exemplary, indirect or business interruption damages; provided, however, that any lost Capacity Attributes, Green Attributes, and ITC benefits (if such ITC benefits are actually lost) (that Seller has not been able to mitigate after use of reasonable efforts) shall be deemed direct damages covered by this Agreement. Without prejudice to the Non-Defaulting Party’s duty to mitigate, the Non-Defaulting Party shall not have to enter into replacement transactions to establish a Settlement Amount. Each Party agrees and acknowledges that (a) the actual damages that the Non-Defaulting Party would incur in connection with a Terminated Transaction would be difficult or impossible to predict with certainty, (b) the Termination Payment described in this section is a reasonable and appropriate approximation of such damages, and (c) the Termination Payment described in this section is the exclusive remedy of the Non-Defaulting Party in connection with a Terminated Transaction but shall not otherwise act to limit any of the Non-Defaulting Party’s rights or remedies if the Non-Defaulting Party does not elect a Terminated Transaction as its remedy for an Event of Default by the Defaulting Party.

5.4 Notice of Payment of Termination Payment. As soon as practicable after a Terminated Transaction, Notice shall be given by the Non-Defaulting Party to the Defaulting Party of the amount of the Termination Payment and whether the Termination Payment is due to the Non-Defaulting Party. The Notice shall include a written statement explaining in reasonable detail the calculation of such amount and the sources for such calculation. The Termination Payment shall be made to the Non-Defaulting Party, as applicable, within ten (10) Business Days after such Notice is effective.

5.5 Disputes With Respect to Termination Payment. If the Defaulting Party disputes the Non-Defaulting Party’s calculation of the Termination Payment, in whole or in part, the Defaulting Party shall, within five (5) Business Days of receipt of the Non-Defaulting Party’s

calculation of the Termination Payment, provide to the Non-Defaulting Party a detailed written explanation of the basis for such dispute. Disputes regarding the Termination Payment shall be determined in accordance with Article 12.

5.6 Rights And Remedies Are Cumulative. Except where liquidated damages are provided as the exclusive remedy, the rights and remedies of a Party pursuant to this Article 5 shall be cumulative and in addition to the rights of the Parties otherwise provided in this Agreement.

5.7 Mitigation. Any Non-Defaulting Party shall be obligated to mitigate its Costs, losses and damages resulting from any Event of Default of the other Party under this Agreement.

5.8 Force Majeure. To the extent either Party is prevented or delayed by Force Majeure from carrying out, in whole or part, its obligations under this Agreement and such Party gives Notice and details of the Force Majeure to the other Party as detailed below, then, the Party impacted by Force Majeure shall be excused from the performance of its obligations to the extent impacted. Within forty-eight (48) hours after becoming aware of the commencement of an event of Force Majeure, the non-performing Party shall provide the other Party with oral notice of the event of Force Majeure, and within two (2) weeks of the commencement of an event of Force Majeure the non-performing Party shall provide the other Party with Notice in the form of a letter describing in detail the particulars of the occurrence giving rise to the Force Majeure claim. Seller shall not substitute Product from any other source for the output of the Project during an outage resulting from Force Majeure. The suspension of performance due to a claim of Force Majeure must be of no greater scope and of no longer duration than is required by the Force Majeure. Buyer shall not be required to make any payments for any Product that Seller fails to Schedule, deliver or provide as a result of Force Majeure during the term of a Force Majeure. This Agreement may be terminated by the non-claiming Party with no further obligation to either Party (other than payment obligations that are due and payable at the time of termination) if a Force Majeure event prevents the performance of a material portion of the obligations hereunder and such Force Majeure event is not resolved within twelve (12) months, or eighteen (18) months if the Force Majeure involves the failure of a long lead time major component of the Project, after the commencement of such Force Majeure event.

ARTICLE SIX: PAYMENT

6.1 Billing and Payment. On or about the tenth (10th) day of each month beginning with the second month of the first Contract Year and every month thereafter, and continuing through and including the first month following the end of the Delivery Term, Seller shall provide to Buyer (a) records of metered data, including CAISO metering and transaction data sufficient to document and verify the generation of Product by the Project for any CAISO settlement time interval during the preceding months, (b) access to any records, including invoices or settlement data from CAISO, necessary to verify the invoice; and (c) an invoice, in a format reasonably specified by Buyer, covering the services provided in the preceding month determined in accordance with Article 4 (which may include preceding months), with all component charges and unit prices identified and all calculations used to arrive at invoiced amounts described in reasonable detail. Buyer shall pay the undisputed amount of such invoices on or before thirty (30) days after receipt of the invoice. If either the invoice date or payment

date is not a Business Day, then such invoice or payment shall be provided on the next following Business Day. Each Party will make payments by electronic funds transfer, or by other mutually agreeable method(s), to the account designated by the other Party. Any undisputed amounts not paid by the due date will be deemed delinquent and will accrue interest at the Default Rate, such interest to be calculated from and including the due date to but excluding the date the delinquent amount is paid in full. Invoices may be sent by facsimile or e-mail.

6.2 Disputes and Adjustments of Invoices. A Party may, in good faith, dispute the correctness of any invoice or any adjustment to an invoice, rendered under this Agreement or adjust any invoice for any arithmetic or computational error within twelve (12) months of the date the invoice, or adjustment to an invoice, was rendered. In the event an invoice or portion thereof, or any other claim or adjustment arising hereunder, is disputed, payment of the undisputed portion of the invoice shall be required to be made when due. Any invoice dispute or invoice adjustment shall be in writing and shall state the basis for the dispute or adjustment. Payment of the disputed amount shall not be required until the dispute is resolved. Upon resolution of the dispute, any required payment shall be made within two (2) Business Days of such resolution along with interest accrued at the Default Rate from and including the original due date to but excluding the date paid. Inadvertent overpayments shall be returned upon request or deducted by the Party receiving such overpayment from subsequent payments, with interest accrued at the Interest Rate from and including the date of such overpayment to but excluding the date repaid or deducted by the Party receiving such overpayment. Any dispute with respect to an invoice is waived if the other Party is not notified in accordance with this Section 6.2 within twelve (12) months after the invoice is rendered or subsequently adjusted, except to the extent any misinformation was from a third party not Affiliated with any Party and such third party corrects its information after the twelve-month period. If an invoice is not rendered within twelve (12) months after the close of the month during which performance occurred, the right to payment for such performance is waived.

6.3 Netting of Payments. The Parties hereby agree that they shall discharge mutual debts and payment obligations due and owing to each other on the same date through netting, in which case all amounts owed by each Party to the other Party for the purchase and sale of Product during the monthly billing period under this Agreement, including any related damages calculated pursuant to Section 3.1(h), interest, and payments or credits, shall be netted so that only the excess amount remaining due shall be paid by the Party who owes it.

ARTICLE SEVEN: LIMITATIONS

7.1 Limitation of Remedies, Liability and Damages. EXCEPT AS SET FORTH HEREIN, THERE IS NO WARRANTY OF MERCHANTABILITY OR FITNESS FOR A PARTICULAR PURPOSE, AND ANY AND ALL IMPLIED WARRANTIES ARE DISCLAIMED. THE PARTIES CONFIRM THAT THE EXPRESS REMEDIES AND MEASURES OF DAMAGES PROVIDED IN THIS AGREEMENT SATISFY THE ESSENTIAL PURPOSES HEREOF. FOR BREACH OF ANY PROVISION FOR WHICH AN EXPRESS REMEDY OR MEASURE OF DAMAGES IS PROVIDED, SUCH EXPRESS REMEDY OR MEASURE OF DAMAGES SHALL BE THE SOLE AND EXCLUSIVE REMEDY, THE OBLIGOR'S LIABILITY SHALL BE LIMITED AS SET FORTH IN SUCH PROVISION AND ALL OTHER REMEDIES OR DAMAGES AT LAW OR IN EQUITY ARE

WAIVED, UNLESS THE PROVISION IN QUESTION PROVIDES THAT THE EXPRESS REMEDIES ARE IN ADDITION TO OTHER REMEDIES THAT MAY BE AVAILABLE. EXCEPT FOR A PARTY'S INDEMNITY OBLIGATION IN RESPECT OF THIRD PARTY CLAIMS OR AS OTHERWISE EXPRESSLY HEREIN PROVIDED, NEITHER PARTY SHALL BE LIABLE FOR CONSEQUENTIAL, INCIDENTAL, PUNITIVE, EXEMPLARY OR INDIRECT DAMAGES, LOST PROFITS OR OTHER BUSINESS INTERRUPTION DAMAGES, BY STATUTE, IN TORT OR CONTRACT, UNDER ANY INDEMNITY PROVISION OR OTHERWISE. UNLESS EXPRESSLY HEREIN PROVIDED, AND SUBJECT TO THE PROVISIONS OF SECTION 11.2 (INDEMNITIES), IT IS THE INTENT OF THE PARTIES THAT THE LIMITATIONS HEREIN IMPOSED ON REMEDIES AND THE MEASURE OF DAMAGES BE WITHOUT REGARD TO THE CAUSE OR CAUSES RELATED THERETO, INCLUDING THE NEGLIGENCE OF ANY PARTY, WHETHER SUCH NEGLIGENCE BE SOLE, JOINT OR CONCURRENT, OR ACTIVE OR PASSIVE. TO THE EXTENT ANY DAMAGES REQUIRED TO BE PAID HEREUNDER ARE LIQUIDATED, THE PARTIES ACKNOWLEDGE THAT THE DAMAGES ARE DIFFICULT OR IMPOSSIBLE TO DETERMINE, OR OTHERWISE OBTAINING AN ADEQUATE REMEDY IS INCONVENIENT AND THE DAMAGES CALCULATED HEREUNDER CONSTITUTE A REASONABLE APPROXIMATION OF THE HARM OR LOSS.

ARTICLE EIGHT: CREDIT AND COLLATERAL REQUIREMENTS

8.1 Buyer Financial Information. If requested by Seller, Buyer shall deliver (i) within one hundred twenty (120) days following the end of each fiscal year, a copy of Buyer's annual report containing audited consolidated financial statements for such fiscal year and (ii) within sixty (60) days after the end of each of its first three fiscal quarters of each fiscal year, a copy of Buyer's quarterly report containing unaudited consolidated financial statements for such fiscal quarter. In all cases the statements shall be for the most recent accounting period and prepared in accordance with generally accepted accounting principles; provided, however, that should any such statements not be available on a timely basis due to a delay in preparation or certification, such delay shall not be an Event of Default so long as Buyer diligently pursues the preparation, certification and delivery of the statements. Buyer shall be deemed to have satisfied such delivery requirement if the applicable report is publicly available.

8.2 Seller Financial Information. Seller shall provide the following financial information:

- (a) If requested by Buyer, Seller shall deliver (i) within one hundred twenty (120) days following the end of each fiscal year, a copy of Seller's annual report containing unaudited consolidated financial statements for such fiscal year certified by an officer of Seller and (ii) within sixty (60) days after the end of each of its first three fiscal quarters of each fiscal year, a copy of Seller's quarterly report containing unaudited consolidated financial statements for such fiscal quarter certified by an officer of Seller. In all cases the statements shall be for the most recent accounting period and prepared in accordance with generally accepted accounting principles; provided, however, that should any such statements not be available on a timely basis due to a

delay in preparation or certification, such delay shall not be an Event of Default so long as Seller diligently pursues the preparation, certification and delivery of the statements.

- (b) If a Guaranty is provided and if requested by Buyer, Seller shall deliver (i) within one hundred twenty (120) days following the end of each fiscal year, a copy of Guarantor's annual report containing audited consolidated financial statements for such fiscal year and (ii) within sixty (60) days after the end of each of its first three fiscal quarters of each fiscal year, a copy of Guarantor's quarterly report containing unaudited consolidated financial statements for such fiscal quarter certified by an officer of Guarantor. In all cases the statements shall be for the most recent accounting period and prepared in accordance with generally accepted accounting principles; provided, however, that should any such statements not be available on a timely basis due to a delay in preparation or certification, such delay shall not be an Event of Default so long as Guarantor diligently pursues the preparation, certification and delivery of the statements. Seller shall be deemed to have satisfied such delivery requirement if the applicable report is publicly available.

8.3 Grant of Security Interest/Remedies. To secure its obligations under this Agreement and to the extent Seller delivers Performance Assurance hereunder, Seller hereby grants to Buyer a present and continuing first priority security interest in, and lien on (and right of setoff against), and assignment of, all cash collateral and cash equivalent collateral and any and all proceeds resulting therefrom or the liquidation thereof, whether now or hereafter held by, on behalf of, or for the benefit of, Buyer, and each Party agrees to take such action as the other Party reasonably requires in order to perfect the Buyer's first-priority security interest in, and lien on (and right of setoff against), such collateral and any and all proceeds resulting therefrom or from the liquidation thereof. Upon or any time after the occurrence and during the continuation of an Event of Default by Seller or an Early Termination Date as a result thereof, Buyer may do any one or more of the following: (i) exercise any of the rights and remedies of a secured party with respect to all Performance Assurance, including any such rights and remedies under Law then in effect; (ii) exercise its rights of setoff against such collateral and any and all proceeds resulting therefrom or from the liquidation thereof; (iii) draw on any outstanding Letter of Credit issued for its benefit; and (iv) liquidate all or any portion of any Performance Assurance then held by or for the benefit of Buyer free from any claim or right of any nature whatsoever of Seller, including any equity or right of purchase or redemption by Seller. Buyer shall apply the proceeds of the collateral realized upon the exercise of any such rights or remedies to reduce the Seller's obligations under the Agreement (Seller remaining liable for any amounts owing to Buyer after such application), subject to Buyer's obligation to return any surplus proceeds remaining after such obligations are satisfied in full.

8.4 Performance Assurance.

- (a) Development Period Security, Construction Period Security, Delivery Term Security. To secure its obligations under this Agreement Seller

agrees to deliver to Buyer and maintain in full force and effect for the period set forth below, the following Performance Assurance:

- (i) Development Period Security in the amount of US\$78,000.00 in the form of cash, a Letter of Credit or a Guaranty from the Execution Date of this Agreement until the later of the CP Satisfaction Date and the date Seller posts Construction Period Security pursuant to subpart (ii) below, with Buyer;
- (ii) Construction Period Security in the amount of US\$660,000.00 in the form of cash, a Letter of Credit or a Guaranty from the CP Satisfaction Date until the later of the commencement of the Delivery Term and the date Seller posts Delivery Term Security pursuant to subpart (iii) below, with Buyer; and
- (iii) Delivery Term Security in the amount of US\$660,000.00 in the form of cash, a Letter of Credit or a Guaranty from the commencement of the Delivery Term until the end of the Delivery Term.

Except as set forth in Section 2.2 as it pertains to the Development Period Security, any such Performance Assurance shall not be deemed a limitation of damages.

(b) Return of Performance Assurance.

- (i) Buyer shall promptly return to Seller the unused portion of the Development Period Security after the earlier of (A) the first date on or after the CP Satisfaction Date that Seller has delivered the Construction Period Security, and (B) termination of the Agreement by either Party under Section 2.4(b) unless it constitutes a termination by Seller under Section 2.4(b)(ii).
- (ii) Buyer shall promptly return to Seller the unused portion of the Construction Period Security after the earlier of (A) the first date on or after the Commercial Operation Date that Seller has delivered the Delivery Term Security, and (B) the date that all payment obligations of the Seller arising under this Agreement, including compensation for penalties, Termination Payment, indemnification payments or other damages are paid in full (whether directly or indirectly such as through set-off or netting) after an Early Termination Date.
- (iii) Buyer shall promptly return to Seller the unused portion of the Delivery Term Security after the following have occurred: (A) the Delivery Term has expired or terminated early; and (B) all payment obligations of the Seller arising under this Agreement, including compensation for penalties, Termination Payment,

indemnification payments or other damages are paid in full (whether directly or indirectly such as through set-off or netting).

8.5 Interest on Cash. If Seller provides Performance Assurance in the form of cash, Buyer shall pay interest on such cash held as Development Period Security, Construction Period Security, or Delivery Term Security, as applicable, at the Interest Rate. On or before each Interest Payment Date, Buyer shall transfer the sum of all accrued and unpaid Interest Amounts due to Seller for such security in the form of cash by wire transfer to the bank account specified under “Wire Transfer” in the Cover Sheet.

8.6 Costs of Letter of Credit. If Seller provides Performance Assurance in the form of a Letter of Credit, in all cases, the costs and expenses assessed by the institution providing the Letter of Credit for establishing, renewing, substituting, canceling, increasing and reducing the amount of (as the case may be) one or more Letters of Credit shall be borne by the Seller.

ARTICLE NINE: GOVERNMENTAL CHARGES

9.1 Cooperation. Each Party shall use reasonable efforts to implement the provisions of and to administer this Agreement in accordance with the intent of the Parties to minimize all taxes, so long as neither Party is materially adversely affected by such efforts.

9.2 Governmental Charges. Seller shall pay or cause to be paid all taxes imposed by any governmental authority (“Governmental Charges”) on or with respect to the Product or the transaction under this Agreement arising prior to the Delivery Point, including, but not limited to, ad valorem taxes and other taxes attributable to the Project, land, land rights or interests in land for the Project. Buyer shall pay or cause to be paid all Governmental Charges on or with respect to the Product or the transaction under this Agreement at and from the Delivery Point. In the event Seller is required by Law or regulation to remit or pay Governmental Charges which are Buyer’s responsibility hereunder, Buyer shall promptly reimburse Seller for such Governmental Charges. If Buyer is required by Law or regulation to remit or pay Governmental Charges which are Seller’s responsibility hereunder, Buyer may deduct such amounts from payments to Seller with respect to payments under the Agreement; if Buyer elects not to deduct such amounts from Seller’s payments, Seller shall promptly reimburse Buyer for such amounts upon request. Nothing shall obligate or cause a Party to pay or be liable to pay any Governmental Charges for which it is exempt under the Law.

ARTICLE TEN: REPRESENTATIONS AND WARRANTIES; COVENANTS

10.1 General Representations and Warranties. On the Execution Date and the CP Satisfaction Date (unless specified below), each Party represents and warrants to the other Party that:

- (a) it is duly organized, validly existing and in good standing under the Laws of the jurisdiction of its formation;
- (b) it has all Governmental Approvals necessary for it to perform its obligations under this Agreement, except for as of the Execution Date
 - (i) CPUC Approval in the case of Buyer, and
 - (ii) all Governmental

Approvals necessary to construct, operate and maintain the Project and related interconnection facilities in the case of Seller;

- (c) the execution, delivery and performance of this Agreement is within its powers, have been duly authorized by all necessary action and do not violate any of the terms and conditions in its governing documents, any contracts to which it is a party or any applicable Law;
- (d) this Agreement and each other document executed and delivered in accordance with this Agreement constitutes a legally valid and binding obligation enforceable against it in accordance with its terms, subject to any Equitable Defenses;
- (e) it is not Bankrupt and, on the Execution Date only, there are no proceedings pending or being contemplated by it or, to its knowledge, threatened against it which would result in it being or becoming Bankrupt;
- (f) On the Execution Date only, there is not pending or, to its knowledge, threatened against it or any of its Affiliates any legal proceedings that could materially adversely affect its ability to perform its obligations under this Agreement;
- (g) no Event of Default with respect to it has occurred and is continuing and no such event or circumstance would occur as a result of its entering into or performing its obligations under this Agreement;
- (h) it is acting for its own account, has made its own independent decision to enter into this Agreement and as to whether this Agreement is appropriate or proper for it based upon its own judgment, is not relying upon the advice or recommendations of the other Party in so doing, and is capable of assessing the merits of and understanding, and understands and accepts, the terms, conditions and risks of this Agreement; and
- (i) it has entered into this Agreement in connection with the conduct of its business and it has the capacity or the ability to make or take delivery of the Product as provided in this Agreement.

10.2 Seller Representations and Warranties. Seller's obligations under this Section 10.2(a) and (b) are subject to Section 4.5:

- (a) Seller, and, if applicable, its successors, represents and warrants that throughout the Delivery Term of this Agreement that: (i) the Project qualifies and is certified by the CEC as an Eligible Renewable Energy Resource ("ERR") as such term is defined in Public Utilities Code Section 399.12 or Section 399.16; and (ii) the Project's output delivered to Buyer qualifies under the requirements of the California Renewables

Portfolio Standard. To the extent a change in Law occurs after execution of this Agreement that causes this representation and warranty to be materially false or misleading, it shall not be an Event of Default if Seller has used commercially reasonable efforts to comply with such change in Law.

- (b) Seller and, if applicable, its successors, represents and warrants that throughout the Delivery Term of this Agreement the Renewable Energy Credits transferred to Buyer conform to the definition and attributes required for compliance with the California Renewables Portfolio Standard, as set forth in CPUC Decision 08-08-028, and as may be modified by subsequent decision of the CPUC or by subsequent legislation. To the extent a change in Law occurs after execution of this Agreement that causes this representation and warranty to be materially false or misleading, it shall not be an Event of Default if Seller has used commercially reasonable efforts to comply with such change in Law.

10.3 Covenants.

- (a) General Covenants. Each Party covenants that throughout the Delivery Term:
 - (i) it shall continue to be duly organized, validly existing and in good standing under the Laws of the jurisdiction of its formation;
 - (ii) it shall maintain (or obtain from time to time as required, including through renewal, as applicable) all Governmental Approvals necessary for it to legally perform its obligations under this Agreement;
 - (iii) it shall perform its obligations under this Agreement in a manner that does not violate any of the terms and conditions in its governing documents, any contracts to which it is a party or any applicable Law; and
 - (iv) it shall not dispute its status as a “forward contract merchant” within the meaning of the United States Bankruptcy Code.
- (b) Seller Covenants.
 - (i) Seller covenants throughout the Delivery Term that it, or its permitted successors or assigns, shall maintain an ownership of a fee or long-term leasehold interest in the Project.
 - (ii) Seller covenants throughout the Delivery Term that it shall maintain market based rate authority from FERC to sell Product to Buyer under the terms of this Agreement.

- (iii) If at any time during the Delivery Term Seller's representations and warranties set forth in Section 10.2 become materially false or misleading, then Seller covenants that it shall provide prompt Notice to Buyer describing the circumstances which make Seller's representation and warranties in Section 10.2 materially false and misleading and the efforts that Seller has undertaken and will undertake so that Seller's representation and warranties in Section 10.2 are no longer materially false and misleading.

ARTICLE ELEVEN: TITLE, RISK OF LOSS, INDEMNITIES

11.1 Title and Risk of Loss. Title to and risk of loss related to the Product shall transfer from Seller to Buyer at the Delivery Point. Seller warrants that it will deliver to Buyer the Product free and clear of all liens, security interests, claims and encumbrances or any interest therein or thereto by any person arising prior to or at the Delivery Point.

11.2 Indemnities.

- (a) Indemnity by Seller. Seller shall release, indemnify, defend, and hold harmless Buyer, its Affiliates, and its and their directors, officers, employees, agents, and representatives against and from any and all actions, suits, losses, costs, damages, injuries, liabilities, claims, demands, penalties and interest, including reasonable costs and attorneys' fees ("Claims") to the extent resulting from or arising out of (i) any event, circumstance, act, or incident relating to the Product delivered under this Agreement up to and at the Delivery Point, (ii) Seller's development, permitting, construction, ownership, operation and/or maintenance of the Project, (iii) the failure by Seller or the failure of the Project to comply with applicable Law, including without limitation the CAISO Tariff, (iv) any Governmental Charges for which Seller is responsible hereunder, or (v) any liens, security interests, encumbrances, or other adverse claims against the Product delivered hereunder made by, under, or through Seller, in all cases including, without limitation, any Claim for or on account of injury, bodily or otherwise, to or death of persons, or for damage to or destruction of property belonging to Buyer, Seller, or others, excepting only such Claim to the extent caused by the willful misconduct or gross negligence of Buyer, its Affiliates, and its and their directors, officers, employees, agents, and representatives.
- (b) Indemnity by Buyer. Buyer shall release, indemnify, defend, and hold harmless Seller, its Affiliates, and its and their directors, officers, employees, agents, and representatives against and from any and all Claims to the extent resulting from or arising out of (i) any event, circumstance, act, or incident relating to the Product received by Buyer under this Agreement at and after the Delivery Point, (ii) the failure by

Buyer to comply with applicable Law, including without limitation the CAISO Tariff, or (iii) any Governmental Charges for which Buyer is responsible hereunder, in all cases including, without limitation, any Claim for or on account of injury, bodily or otherwise, to or death of persons, or for damage to or destruction of property belonging to Buyer, Seller, or others, excepting only such Claim to the extent caused by the willful misconduct or gross negligence of Seller, its Affiliates, and its and their directors, officers, employees, agents, and representatives.

ARTICLE TWELVE: DISPUTE RESOLUTION

12.1 Intent of the Parties. Except as provided in the next sentence, the sole procedure to resolve any claim arising out of or relating to this Agreement or any related agreement is the dispute resolution procedure set forth in this Article 12. Either Party may seek a preliminary injunction or other provisional judicial remedy if such action is necessary to prevent irreparable harm or preserve the status quo, in which case both Parties nonetheless will continue to pursue resolution of the dispute by means of the dispute resolution procedure set forth in this Article 12.

12.2 Management Negotiations.

- (a) The Parties will attempt in good faith to resolve any controversy or claim arising out of or relating to this Agreement by prompt negotiations between each Party's authorized representative designated in writing as a representative of the Party (each a "Manager"). Either Manager may request a meeting to initiate negotiations to be held within ten (10) Business Days of the other Party's receipt of such request, at a mutually agreed time and place (either in person or telephonically). If the matter is not resolved within fifteen (15) Business Days of their first meeting ("Initial Negotiation End Date"), the Managers shall refer the matter to the designated senior officers of their respective companies that have authority to settle the dispute ("Executive(s)"). Within five (5) Business Days of the Initial Negotiation End Date ("Referral Date"), each Party shall provide one another Notice confirming the referral and identifying the name and title of the Executive who will represent the Party.
- (b) Within five (5) Business Days of the Referral Date, the Executives shall establish a mutually acceptable location and date, which date shall not be greater than thirty (30) days from the Referral Date, to meet. After the initial meeting date, the Executives shall meet, as often as they reasonably deem necessary, to exchange relevant information and to attempt to resolve the dispute.
- (c) All communication and writing exchanged between the Parties in connection with these negotiations shall be confidential and shall not be

used or referred to in any subsequent binding adjudicatory process between the Parties.

- (d) If the matter is not resolved within forty-five (45) days of the Referral Date, or if the Party receiving the written request to meet, pursuant to Section 12.2(a) above, refuses or does not meet within the ten (10) Business Day period specified in Section 12.2(a) above, either Party may initiate arbitration of the controversy or claim by providing Notice of a demand for binding arbitration at any time thereafter.

12.3 Arbitration. Any dispute that cannot be resolved by management negotiations as set forth in Section 12.2 above shall be resolved through binding arbitration by a retired judge or justice from the AAA panel conducted in San Diego, California, administered by and in accordance with AAA's Commercial Arbitration Rules ("Arbitration").

- (a) Any arbitrator shall have no affiliation with, financial or other interest in, or prior employment with either Party and shall be knowledgeable in the field of the dispute. The Parties shall cooperate with one another in selecting the arbitrator within sixty (60) days after Notice of the demand for arbitration. If, notwithstanding their good faith efforts, the Parties are unable to agree upon a mutually-acceptable arbitrator, the arbitrator shall be appointed as provided for in AAA's Commercial Arbitration Rules.
- (b) At the request of a Party, the arbitrator shall have the discretion to order depositions of witnesses to the extent the arbitrator deems such discovery relevant and appropriate. Depositions shall be limited to a maximum of three (3) per Party and shall be held within thirty (30) days of the making of a request. Additional depositions may be scheduled only with the permission of the arbitrator, and for good cause shown. Each deposition shall be limited to a maximum of six (6) hours duration unless otherwise permitted by the arbitrator for good cause shown. All objections are reserved for the Arbitration hearing except for objections based on privilege and proprietary and confidential information. The arbitrator shall also have discretion to order the Parties to exchange relevant documents. The arbitrator shall also have discretion to order the Parties to answer interrogatories, upon good cause shown.
- (c) The arbitrator shall have no authority to award punitive or exemplary damages or any other damages other than direct and actual damages and the other remedies contemplated by this Agreement.
- (d) The arbitrator's award shall be made within nine (9) months of the filing of the notice of intention to arbitrate (demand) and the arbitrator shall agree to comply with this schedule before accepting appointment.

However, this time limit may be extended by agreement of the Parties or by the arbitrator, if necessary.

- (e) Judgment on the award may be entered in any court having jurisdiction.
- (f) The prevailing Party in this dispute resolution process is entitled to recover its costs. Until such award is made, however, the Parties shall share equally in paying the costs of the Arbitration.
- (g) The arbitrator shall have the authority to grant dispositive motions prior to the commencement of or following the completion of discovery if the arbitrator concludes that there is no material issue of fact pending before the arbitrator.
- (h) The existence, content, and results of any Arbitration hereunder is confidential information that is subject to the provisions of Section 13.1.

ARTICLE THIRTEEN: MISCELLANEOUS

13.1 Confidentiality.

- (a) General. Neither Party shall disclose the non-public terms or conditions of this Agreement or any transaction hereunder to a third party, other than (i) the Party's Affiliates and its and their officers, directors, employees, lenders, investors, contractors, counsel, accountants, or advisors who have a need to know such information and have agreed to keep such terms confidential, (ii) for disclosure to the Buyer's Procurement Review Group, as defined in CPUC Decision (D) 02-08-071, subject to a confidentiality agreement, (iii) to the CPUC under seal for purposes of review, (iv) disclosure of terms specified in and pursuant to Section 13.1(b) of this Agreement; (v) in order to comply with any applicable Law, regulation, or any exchange, control area or CAISO rule, or order issued by a court or entity with competent jurisdiction over the disclosing Party ("Disclosing Party"), other than to those entities set forth in subsection (vi); or (vi) in order to comply with any applicable regulation, rule, or order of the CPUC, CEC, or the Federal Energy Regulatory Commission. In connection with requests made pursuant to clause (v) of this Section 13.1(a) ("Disclosure Order") each Party shall, to the extent practicable, use reasonable efforts to (i) notify the other Party prior to disclosing the confidential information, if practicable, and (ii) prevent or limit such disclosure. After using such reasonable efforts, the Disclosing Party shall not be: (i) prohibited from complying with a Disclosure Order or (ii) liable to the other Party for monetary or other damages incurred in connection with the disclosure of the confidential information. Except as provided in the preceding sentence, the Parties shall be entitled to all remedies available at law or

in equity to enforce, or seek relief in connection with, this confidentiality obligation.

- (b) RPS Confidentiality. Notwithstanding Section 13.1(a) of this Agreement, at any time on or after the date on which the Buyer makes its filing seeking CPUC Approval of this Agreement, either Party shall be permitted to disclose the following terms with respect to this Agreement: Party names, resource type, Delivery Term, Project location, Contract Capacity, anticipated Commercial Operation Date, Contract Quantity, and Delivery Point.
- (c) Publicity. Except as otherwise agreed to in this Section 13.1 above, no announcement, publicity, advertising, press release, promotional or marketing materials regarding the arrangement contemplated under this Agreement, including the existence hereof, shall be made by either Party without the prior written approval of the other Party which approval shall not be unreasonably withheld or delayed.

13.2 Assignment. Neither Party shall assign this Agreement or its rights hereunder without the prior written consent of the other Party, which consent shall not be unreasonably withheld. For purposes hereof, a change in control of Seller (or any entity holding a direct or indirect equity interest in Seller if such interest constitutes more than twenty percent (20%) of the value of such entity), or a merger, consolidation or reorganization of Seller shall also constitute an assignment of this Agreement requiring Buyer's prior written consent, which shall not be unreasonably withheld or delayed; provided, however, Buyer agrees to consent to an assignment by Seller through a change in control or a merger, consolidation or reorganization of Seller if (i) the creditworthiness of the "Seller" hereunder would not be materially and adversely affected; and (ii) the proposed transferee or the managing member or other similar entity controlling the management of Seller following the proposed transfer has, either itself or by contract with other parties, at least five (5) years experience and expertise in the operation of power plants. Notwithstanding the foregoing, either Party may, without the consent of the other Party (and without relieving itself from liability hereunder), transfer, sell, pledge, encumber, or assign this Agreement or the accounts, revenues or proceeds hereof to its financing providers. In connection with any financing or refinancing of the Project by Seller, Buyer shall in good faith negotiate and agree upon a consent to collateral assignment of this Agreement in a form that is commercially reasonable and customary in the industry.

13.3 Audit. Each Party has the right, at its sole expense and during normal working hours, to examine the records of the other Party to the extent reasonably necessary to verify the accuracy of any statement, charge or computation made pursuant to this Agreement including amounts of Delivered Energy or Scheduled Energy, or to verify Seller's representation and warranties in Section 10.2. If any such examination reveals any inaccuracy in any statement, the necessary adjustments in such statement and the payments thereof will be made promptly and shall bear interest calculated at the Default Rate from the date the overpayment or underpayment was made until paid; provided, however, that no adjustment for any statement or payment will be made unless objection to the accuracy thereof was made prior to the lapse of twelve (12) months from the rendition thereof, and thereafter any objection shall be deemed waived except to the

extent any misinformation was from a third party not Affiliated with any Party and such third party corrects its information after such twelve-month period.

13.4 Sarbanes-Oxley and Securities and Exchange Commission Requirements.

- (a) The Parties acknowledge that accounting principles generally accepted in the United States of America (“GAAP”) and Securities and Exchange Commission (“SEC”) rules require Buyer and its independent auditor to evaluate whether Buyer must consolidate Seller’s financial information (but not financial information of Seller’s constituent members unless deemed to be included in the entity under GAAP). Buyer will require access to certain records, including but not limited to financial records, and personnel of Seller to determine if consolidated financial reporting is required. If Buyer and its independent auditor determine at any time that the Buyer must consolidate the Seller’s financial statements to comply with GAAP and/or SEC rules regarding consolidated financial reporting, Buyer shall require from Seller and Seller agrees to provide to Buyer the following during the Term of this Agreement:
 - (i) Unaudited financial statements of the Seller prepared in accordance with GAAP as of the end of the quarterly period. The financial statements should include quarter to date and year to date information and are to be provided within fifteen (15) calendar days of the end of the applicable reporting period (or the Business Day thereafter);
 - (ii) Unaudited financial schedules of the Seller, as deemed necessary for Buyer to prepare Buyer’s consolidated financial statements and related footnotes to the financial statements in accordance with GAAP as of the end of the quarterly period. The financial schedules should include quarter to date and year to date information underlying the financial statements and footnotes to the financial statements and are to be provided within twenty (20) calendar days of the end of the applicable reporting period (or the Business Day thereafter);
 - (iii) Access to Seller’s records, accounting and other, and accounting and management personnel as reasonably determined by both Buyer and Seller so that (A) Buyer’s independent auditor or its internal auditors may conduct financial audits (in accordance with the standards of the Public Company Accounting Oversight Board (United States)) as well as internal control audits (in accordance with Section 404 of the Sarbanes-Oxley Act of 2002) and (B) Buyer can be provided analytical information, as needed, to enable Buyer to meet its SEC filing requirements, including but not limited to those under Item 2 on Form 10-Q, and Item 7 on

Form 10-K, "Management's Discussion and Analysis of Financial Condition and Results of Operations;"

- (iv) Upon the request of Buyer, and whether or not Seller is otherwise required by Law to provide them, such certifications by a duly authorized representative(s) of Seller as may be reasonably requested by Buyer (which certifications shall presumptively be reasonable if the certifications are substantially identical to those required by Buyer or its parent or business units of Buyer or its parent); and
 - (v) As reasonably requested by Buyer, such information or schedules, similar to the items noted in clauses (i)-(iv) above, to enable Buyer to prepare consolidated financial statements and schedules as may be required for Buyer to obtain financing or to prepare other reports as required by regulatory bodies, such as the SEC, for periods other than as of the end of the monthly, quarterly or year to date periods then ended.
- (b) If Buyer (i) in its sole discretion determines that the financial statements of the Seller would be considered material to the Buyer or its parent company's financial statements, financial condition, or internal controls over financial reporting, and (ii) reasonably determines Seller's internal controls over financial reporting are not operating effectively or have resulted in a control deficiency, Buyer shall provide Notice to Seller. Upon receipt of such Notice, Seller will have thirty (30) days to remediate any significant deficiency in Seller's internal controls over financial reporting identified by the Buyer, which Buyer and Buyer's independent auditor deem to be necessary to ensure Seller's internal controls over financial reporting are adequate, during or as a result of the audits permitted under Section 13.4(a)(iii) or any other provision of this Agreement.
- (c) As soon as possible, but in no event later than two (2) Business Days following any occurrence that would affect Seller in any material way, Seller shall provide to Buyer a Notice describing such occurrence in sufficient detail to permit the Buyer to file a report on SEC Form 8-K. Such occurrences include all reportable events on the then current Form 8-K that applies to Buyer and its parent company at such time, including but not limited to a material acquisition or disposition of assets, a material direct financial obligation or off-balance sheet financing arrangement, material litigation, and the execution or termination of a material contract.
- (d) Any information provided to Buyer shall be treated as confidential except that it may be disclosed in connection with the preparation, review, certification and publication of Buyer's financial statements.

- (e) Seller shall notify Buyer at any time during the term of this Agreement of any services provided or proposed to be provided to Seller by Buyer's independent auditor. Seller is prohibited from engaging Buyer's independent auditor for any services or in any consulting agreement without the express written consent of partner in charge of Buyer's independent audit.

13.5 Entire Agreement. This Agreement, together with the Cover Sheet and each and every appendix, attachment, amendment, schedule and any written supplements hereto, if any, between the Parties constitutes the entire agreement between the Parties.

13.6 Recording. Unless a Party expressly objects to a Recording (defined below) at the beginning of a telephone conversation, each Party consents to the creation of a tape or electronic recording ("Recording") of all telephone conversations between the Parties to this Agreement, and that any such Recordings will be retained in confidence, secured from improper access, and may be submitted in evidence in any proceeding or action relating to this Agreement. Each Party waives any further notice of such monitoring or recording, and agrees to notify its officers and employees of such monitoring or recording and to obtain any necessary consent of such officers and employees.

13.7 Forward Contract. The Parties acknowledge and agree that this Agreement constitutes a "forward contract" within the meaning of the United States Bankruptcy Code.

13.8 Governing Law. THIS AGREEMENT AND THE RIGHTS AND DUTIES OF THE PARTIES HEREUNDER SHALL BE GOVERNED BY AND CONSTRUED, ENFORCED AND PERFORMED IN ACCORDANCE WITH THE LAWS OF THE STATE OF CALIFORNIA, WITHOUT REGARD TO PRINCIPLES OF CONFLICTS OF LAW. TO THE EXTENT ENFORCEABLE AT SUCH TIME, EACH PARTY WAIVES ITS RESPECTIVE RIGHT TO ANY JURY TRIAL WITH RESPECT TO ANY LITIGATION ARISING UNDER OR IN CONNECTION WITH THIS AGREEMENT.

13.9 Attorneys' Fees. In any proceeding brought to enforce this Agreement or because of the breach by any Party of any covenant or condition herein contained, the prevailing Party shall be entitled to reasonable attorneys' fees (including reasonably allocated fees of in-house counsel) in addition to court costs and any and all other costs recoverable in said action.

13.10 General. This Agreement shall be considered for all purposes as prepared through the joint efforts of the Parties and shall not be construed against one Party or the other as a result of the preparation, substitution, submission or other event of negotiation, drafting or execution hereof. Except to the extent provided for herein, no amendment or modification to this Agreement shall be enforceable unless reduced to writing and executed by both Parties. This Agreement shall not impart any rights enforceable by any third party (other than a permitted successor or assignee bound to this Agreement). Waiver by a Party of any default by the other Party shall not be construed as a waiver of any other default. The headings used herein are for convenience and reference purposes only. This Agreement shall be binding on each Party's successors and permitted assigns.

13.11 Severability. If any provision in this Agreement is determined to be invalid, void or unenforceable by any court having jurisdiction, such determination shall not invalidate, void, or make unenforceable any other provision, agreement or covenant of this Agreement and the Parties shall use their best efforts to modify this Agreement to give effect to the original intention of the Parties.

13.12 Counterparts. This Agreement may be executed in one or more counterparts each of which shall be deemed an original and all of which shall be deemed one and the same Agreement. Delivery of an executed counterpart of this Agreement by fax will be deemed as effective as delivery of an originally executed counterpart. Any Party delivering an executed counterpart of this Agreement by facsimile will also deliver an originally executed counterpart, but the failure of any Party to deliver an originally executed counterpart of this Agreement will not affect the validity or effectiveness of this Agreement.

13.13 Notices. Whenever this Agreement requires or permits delivery of a "Notice" (or requires a Party to "notify"), the Party with such right or obligation shall provide a written communication in the manner specified in herein; provided, however, that notices of Outages or other Scheduling or dispatch information or requests, shall be provided in accordance with the terms set forth in the relevant section of this Agreement. Invoices may be sent by facsimile or e-mail. A Notice sent by facsimile transmission or e-mail will be recognized and shall be deemed received on the Business Day on which such Notice was transmitted if received before 5:00 p.m. (and if received after 5:00 p.m., on the next Business Day) and a Notice of overnight mail or courier shall be deemed to have been received two (2) Business Days after it was sent or such earlier time as is confirmed by the receiving Party. Each Party shall provide Notice to the other Party of the persons authorized to nominate and/or agree to a Schedule or Dispatch Order for the delivery or acceptance of the Product or make other Notices on behalf of such Party and specify the scope of their individual authority and responsibilities, and may change its designation of such persons from time to time in its sole discretion by providing Notice.

13.14 Mobile Sierra. Notwithstanding any provision of this Agreement, neither Party shall seek, nor shall they support any third party in seeking, to prospectively or retroactively revise the rates, terms or conditions of service of this Agreement through application or complaint to FERC pursuant to the provisions of Section 205, 206 or 306 of the Federal Power Act, or any other provisions of the Federal Power Act, absent prior written agreement of the Parties. Further, absent the prior agreement in writing by both Parties, the standard of review for changes to the rates, terms or conditions of service of this Agreement proposed by a Party, a non-Party or the FERC acting *sua sponte* shall be the "public interest" application of the "just and reasonable" standard of review set forth in *United Gas Pipe Line Co. v. Mobile Gas Service Corp.*, 350 US 332 (1956) and *Federal Power Commission v. Sierra Pacific Power Co.*, 350 US 348 (1956).

[Remainder of page intentionally left blank]

IN WITNESS WHEREOF, the Parties have caused this Agreement to be duly executed as of the date first above written.

NRG SOLAR BORREGO I LLC
a Delaware limited liability company

SAN DIEGO GAS & ELECTRIC COMPANY
a California corporation

By:

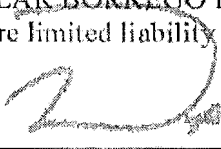

Name: Tom Doyle
Title: President

By:

Name: Matt Burkhart
Title: Vice President of
Electric & Fuel Procurement

IN WITNESS WHEREOF, the Parties have caused this Agreement to be duly executed as of the date first above written.

NRG SOLAR BORREGO I LLC
a Delaware limited liability company

SAN DIEGO GAS & ELECTRIC COMPANY
a California corporation

By: _____
Name: _____
Title: _____

By: 
Name: Matt Burkhart
Title: Vice President of
Electric & Fuel Procurement

APPROVED as to legal form a.s.

Exhibit A

PROJECT DESCRIPTION INCLUDING DESCRIPTION OF SITE

PROJECT DESCRIPTION

Project name: NRG Solar Borrego I LLC

Project Site name: Borrego PV I

Project physical address: Borrego Valley Road, Borrego Springs, CA

Technology Type: Photovoltaic

Substation: Borrego

The term "Site" as defined in the Agreement means the following parcel description upon which the Project is located:

The Project Site is approximately 204 acres of private land in Borrego Springs. It is located within property bounded by Borrego Valley Road on the east and Henderson Canyon Road on the north.

The nameplate capacity of the Project is 26 MW.

The electric generating units utilized as generation assets as part of the Project are described in the following single line diagram.

NRG Solar Borrego I LLC 26 MW

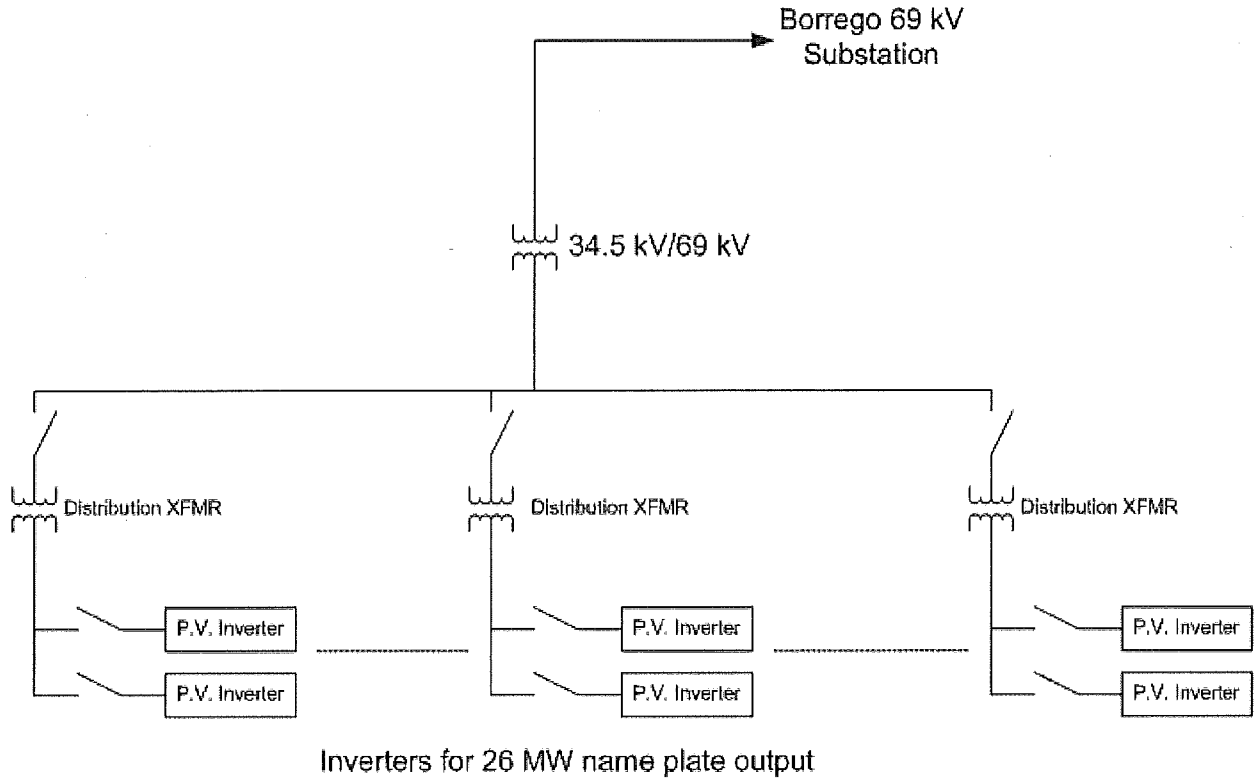

Exhibit B

MILESTONE SCHEDULE

<i>No.</i>	<i>Date</i>	<i>Milestones</i>
1.	Sept 30, 2011	Receives CEC Certification and Verification.
2.	Sept 30, 2011	Obtains control of all lands and rights-of-way comprising the Site.
3.	Sept 30, 2011	Executes an Engineering, Procurement and Construction (“EPC”) contract.
4.	Sept 30, 2011	Receives all Governmental Approvals, including the <i>San Diego County Major Use Permit</i>
5.	Sept 30, 2011	Completes financing.
6.	Oct 31, 2011	Delivers full NTP under EPC contract and begins construction of the Project.
7.	June 30, 2012	Begins startup activities.
8.	June 30, 2012	Executes Meter Service Agreement and Participating Generator Agreement.
9.	July 15, 2012	Achieves initial operation.
10.	July 30, 2012	Demonstrates the Contract Capacity.
11.	July 31, 2012	Commercial Operation Date.

Exhibit C

FORM OF LETTER OF CREDIT

[DATE]

To: [Name and Address of Secured Party]

Re: Our Irrevocable Standby Letter of Credit No. _____
In the Amount of US _____

Gentlemen:

We hereby open our irrevocable standby Letter of Credit Number _____ in favor of [name of Secured Party] (“Secured Party”), by order and for account of [name of Account Party] (“Account Party”), [address of Account Party], available at sight upon demand at our counters, at [location] for an amount of US\$ _____ [amount spelled out and xx/100 U.S. Dollars] against presentation one of the following documents:

- 1- Statement signed by a person purported to be an authorized representative of Secured Party stating that: “[name of Account Party] (“Account Party”) is in default under the agreement between Secured Party and Account Party dated _____ or under any transaction contemplated thereby (whether by failure to perform or pay any obligation thereunder or by occurrence of a “default”, “event of default” or similar term as defined in such agreement, any other agreement between Secured Party and Account Party, or otherwise). The amount due to Secured Party is US \$_____.”

or

- 2- Statement signed by a person purported to be an authorized representative of Secured Party stating that: “as of the close of business on ____ [insert date, which is less than 60 days prior to the expiration date of the Letter of Credit] you have provided written notice to us indicating your election not to permit extension of this Letter of Credit beyond its current expiry date. The amount due to Secured Party, whether or not a default has occurred, is U.S. \$_____.”

Special Conditions:

- All costs and banking charges pertaining to this Letter of Credit are for the account of Account Party.
- Partial and multiple drawings are permitted.

- Fax of Document 1 or 2 above acceptable.

This Letter of Credit expires on _____ at our counters.

We hereby engage with Secured Party that upon presentation of a document as specified under and in compliance with the terms of this Letter of Credit, this Letter of Credit will be duly honored in the amount stated in Document 1 or 2 above. If a document is so presented by 1:00 pm on any New York banking day, we will honor the same in full in immediately available New York funds on that day and, if so presented after 1:00 pm on a New York banking day, we will honor the same in full in immediately available New York funds by noon on the following New York banking day.

It is a condition of this Letter of Credit that it shall be deemed automatically extended without an amendment for a one year period beginning on the present expiry date hereof and upon each anniversary of such date, unless at least ninety (90) days prior to any such expiry date we have sent you written notice by regular and registered mail or courier service that we elect not to permit this Letter of Credit to be so extended beyond, and will expire on its then current expiry date. No presentation made under this Letter of Credit after such expiry date will be honored.

We agree that if this Letter of Credit would otherwise expire during, or within 30 days after, an interruption of our business caused by an act of god, riot, civil commotion, insurrection, act of terrorism, war or any other cause beyond our control or by any strike or lockout, then this Letter of Credit shall expire on the 30th day following the day on which we resume our business after the cause of such interruption has been removed or eliminated and any drawing on this Letter of Credit which could properly have been made but for such interruption shall be permitted during such extended period.

This Letter of Credit is subject to the Uniform Customs and Practice for Documentary Credits (2007 Revision) International Chamber of Commerce, Publication No. 600 ("UCP"), except to the extent that the terms hereof are inconsistent with the provisions of the UCP, including but not limited to Articles 14(b) and 36 of the UCP, in which case the terms of this Letter of Credit shall govern. Matters not covered by the UCP shall be governed and construed in accordance with the laws of the State of California.

[Name of Bank]

Authorized Signature(s)

Exhibit D

FORM OF GUARANTY

GUARANTY

In consideration of San Diego Gas and Electric Company ("Company") entering into a power purchase agreement with [NAME OF COUNTERPARTY] (hereinafter referred to as "Applicant"), [NAME OF GUARANTOR], a [TYPE OF LEGAL ENTITY i.e. California corporation], (hereinafter referred to as "Guarantor") agrees with Company as follows:

1. The term "Obligations" shall mean all obligations, liabilities and indebtedness of any kind whatsoever arising in connection with _____ or arising in connection with or under any security agreement or other agreement between the Company and Applicant. The amount of Obligations existing from time to time shall be calculated after giving effect to all contractual netting arrangements between Applicant and the Company.

2. Guarantor unconditionally and irrevocably guarantees to Company the full, prompt and faithful payment and performance when due of each and all of the Obligations.

3. This is a continuing guaranty relating to the Obligations. Guarantor acknowledges that there is a continuing consideration to Guarantor for this Guaranty and therefore Guarantor waives and relinquishes the right to revoke or terminate this Guaranty as provided in California Civil Code Section 2815.

4. Any of the Obligations may be amended, modified, waived, or increased (whether or not beyond any dollar limitation hereunder), further agreements may be entered into between Company and Applicant, Company may provide additional goods or services or credit to Applicant or increase or decrease the dollar value of such goods, services or credit, and further obligations (including, without limitation, the provision or pledging of security to Company for any obligation), indebtedness and liabilities may be entered into or incurred from time to time by Applicant and without further authorization from or notice to Guarantor and no such action shall terminate, release, impair, reduce, discharge, diminish or in any way affect any of the obligations of Guarantor hereunder or any security furnished by Guarantor or give Guarantor any recourse or defense against Company. Company need not inquire into the power of Applicant or the authority of its officers, directors, partners or agents acting or purporting to act in its behalf.

5. With respect to all Obligations, this is a guaranty of payment and performance and not of collection, and Guarantor waives and agrees not to assert or take advantage of:

(a) any right to require Company to proceed against Applicant or any other person or to resort to, proceed against or exhaust any security held by it at any time or to pursue any other remedy in its power before proceeding against any Guarantor;

(b) demand, presentment, protest and notice of any kind including, without limiting the generality of the foregoing, notice of nonperformance, protest, dishonor and

acceptance of this Guaranty, notice under Section 9611 of the California Commercial Code, and notice of the existence, creation or incurring of any new or additional indebtedness or obligation or of any action or non-action on the part of Applicant, Company, a guarantor under this or any other instrument, or creditor of Applicant or any other person whomsoever, in connection with any of the Obligations or any collateral for any of the Obligations or in connection with any of the Obligations; and

(c) any suretyship defenses and suretyship rights of every nature otherwise available under California law and the laws of any other state or jurisdiction, including, without limitation, all defenses and rights arising under Sections 2787 through 2855 of the California Civil Code (the "Suretyship Provisions") and any successor provisions to those Sections. Without limiting the generality of the foregoing, Guarantor acknowledges his, her or its understanding that the Suretyship Provisions provide various partial or complete defenses to the recovery by Company from Guarantor and/or grant Guarantor rights the enforcement of which could reduce or eliminate entirely Guarantor's liability hereunder to Company. Among the defenses and rights contained in the Suretyship Provisions are the following: (1) Section 2809 of the Civil Code, which provides, in part, that the obligation of a surety must not be either larger in amount or in other respects more burdensome than that of the principal; (2) Section 2810 of the Civil Code, which provides, in part, that a surety is not liable if for any reason other than the mere personal disability of the principal there is no liability upon the part of the principal at the time of execution of the contract, or the liability of the principal thereafter ceases; (3) Section 2819 of the Civil Code, which provides, in part, that a surety is exonerated if the creditor alters the original obligation of the principal without the consent of the surety; (4) Section 2845 of the Civil Code, which provides, in part, that a surety is exonerated to the extent that the creditor fails to proceed against the principal, or to pursue any other remedy in the creditor's power which the surety cannot pursue and which would lighten the surety's burden; (5) Section 2846 of the Civil Code, which provides that a surety may compel his principal to perform the obligation when due; (6) Section 2847 of the Civil Code, which provides, in part, that if a surety satisfies the principal obligation, or any part thereof, the principal is obligated to reimburse the surety for the amounts paid by the surety; (7) Section 2848 of the Civil Code, which provides, in part, that a surety, upon satisfaction of the obligation of the principal is entitled to enforce remedies which the creditor then has against the principal; (8) Section 2849 of the Civil Code, which provides, in part, that a surety is entitled to the benefit of security held by the creditor for the performance of the principal obligation held by the creditor; (9) Section 2850 of the Civil Code, which provides, in part, that whenever the property of a surety is hypothecated with property of the principal, the surety is entitled to have the property of the principal first applied to the discharge of the obligation; and (10) Section 2822 of the Civil Code, which provides, in part, for a right to have the principal designate the portion of any obligation to be satisfied by the surety in the event that the principal provides partial satisfaction of such obligation.

6. All existing and future indebtedness of Applicant to Guarantor ("Intercompany Obligations") is subordinated to all Obligations hereby guaranteed. All of Guarantor's right, title and interest in and to the Intercompany Obligations and rights to receive any payments of the Intercompany Obligations are hereby granted and assigned to Company as continuing security for the Obligations hereby guaranteed, and, in the event of any default in the payment of any of the Obligations when due and until the Obligations guaranteed hereby have been paid in full (a) at the Company's request, Applicant shall forthwith pay to the Company all or any part of such

Intercompany Obligations and any capital which Guarantor is entitled to withdraw until all of the Obligations guaranteed hereby have been paid in full, and (b) Guarantor shall pay to Company immediately any payments of such Intercompany Obligations received by Guarantor.

7. Guarantor agrees to pay all attorneys' fees (including without limitation, reasonably allocated fees of in-house counsel) and all other costs and expenses which may be incurred by Company in the enforcement of this Guaranty against Guarantor.

8. This Guaranty is not assignable by Guarantor without Company's consent. This Guaranty shall inure to the benefit of Company and its successors and assigns, including the assignees of any Obligations, and bind the heirs, executors, administrators, successors and permitted (if any) assigns of Guarantor. This Guaranty is assignable by Company with respect to all or any portion of the Obligations, and when so assigned Guarantor shall be liable to the assignees under this Guaranty without in any manner affecting the liability of Guarantor hereunder with respect to any Obligations retained by Company.

9. This Guaranty shall be governed by and construed in accordance with the laws of the State of California, without reference to its choice of law provisions. Guarantor hereby irrevocably and unconditionally agrees that any legal action or proceeding against Guarantor or any of Guarantor's property with respect to this Guaranty may be brought in the courts of the State of California in the County of San Diego or the courts of the United States in the County of San Diego, as Company may elect, and by executing and delivering this Guaranty Guarantor hereby submits to and accepts with regard to any such action or proceeding for himself, herself or itself and in respect of his, her or its property, generally, irrevocably and unconditionally, the jurisdiction of the above mentioned courts. Guarantor hereby irrevocably appoints the Secretary of State of the State of California as his, her or its agent for service of process in any suit or proceeding if the Guarantor is located outside the State of California at the time of service or cannot reasonably be located by Company. The foregoing, however, shall not limit the right of Company as it may elect to bring any legal action or proceeding or to obtain execution of judgment in any other appropriate jurisdiction including but not limited to any other jurisdiction in which Guarantor or his, her or its property is located.

10. Except as provided in any other written agreement now or at any time hereafter in force between Company and Guarantor, this Guaranty shall constitute the entire agreement of Guarantor with Company with respect to the subject matter hereof and no representation, understanding, promise or condition concerning the subject matter hereof shall be binding upon Company unless expressed herein.

11. All notices, demands, requests and other communications required or permitted hereunder shall be in writing and shall be given personally, by certified or registered mail, postage prepaid, return receipt requested, or by reliable overnight courier to the address of the Company set forth below (or to such new address as Company may designate hereafter in a notice to Guarantor) in the case of a communication to the Company and to the address appearing next to Guarantor's signature on this Guaranty (or to such new address as Guarantor may designate hereafter in a notice to Company) in the case of a communication to Guarantor. Any notice served personally shall be deemed delivered upon receipt, and any notice served by certified or registered mail or by reliable overnight courier shall be deemed delivered on the date

of receipt as shown on the addressee's registry or certification of receipt or on the date receipt is refused as shown on the records or manifest of the U.S. Postal Service or such courier.

San Diego Gas and Electric Company
555 W. Fifth Street
Attn: Major Markets 10E3, Credit Manager
Los Angeles, CA 90013
Fax No.: (213) 244-8316

12. Until all of the Obligations guaranteed hereby have been satisfied in full, Guarantor shall have no right of subrogation or reimbursement from the Applicant which Guarantor may have as a result of any payment by Guarantor under this Guaranty, and waives any right to enforce any remedy which Company now has or may hereafter have against the Applicant as a result of such payment by Guarantor under this Guaranty and waives any right under section 2849 of the California Civil Code and any other benefit of or right to participate in any security now or hereafter held by Company.

13. All amounts payable by Guarantor hereunder shall be paid without set-off or counterclaim and without any deduction or withholding whatsoever unless and to the extent that Guarantor shall be prohibited by law from doing so, in which case Guarantor shall pay to Company such additional amount as shall be necessary to ensure that Company receives the full amount it would have received if no such deduction or withholding had been made.

14. If any portion of this Guaranty is held to be unenforceable by a court of competent jurisdiction, the remainder of this Guaranty shall remain in full force and effect.

IN WITNESS WHEREOF, the undersigned Guarantor has executed this Guaranty on [MONTH AND DAY], 2011.

GUARANTOR: [NAME OF
GUARANTOR]

Signature

Title

Printed Name of Person Signing for
Guarantor

Guarantor's Address

City, State, Zip

Guarantor's Phone No.

Exhibit E

COMMERCIAL OPERATION CERTIFICATE

The undersigned, _____ (“EPC Contractor”), _____ (“[_____] Supplier”), _____ (“Licensed Professional Engineer”) and [_____] (“Owner”) make the following certifications to San Diego Gas & Electric Company (“SDG&E”), dated as of _____. All capitalized terms not otherwise defined herein shall have the meaning given to them in the Sale Agreement dated _____ between Owner and SDG&E (the “Agreement”).

[Major Generation Equipment Supplier or Licensed Professional Engineer] hereby certifies that:

1. The [_____] comprising the Project have been erected and installed at the project site and have been commissioned as required under the Supply and Installation Agreement (“[_____] Supply Agreement”) dated as of _____, by and between [_____] Supplier and Owner and each such [_____] has passed the performance testing required to be performed pursuant to the [_____] Supply Agreement.
2. The Warranty Period under the Warranty Agreement (“Warranty Agreement”) dated as of _____, by and between [_____] Supplier and Owner has commenced.

[EPC Contractor or Licensed Professional Engineer] hereby certifies that:

All requirements necessary to achieve [Commercial Operation/Substantial Completion] as set forth in the agreement between the EPC Contractor and Owner dated _____ (“EPC Contract”) have been completed and the Project has successfully passed all performance tests at a level that demonstrates satisfaction of at least the [minimum performance guarantees].

Owner hereby certifies that:

1. Except for punch list items that would not materially affect the performance, reliability or safe operation of the Project, the Project has been completed in accordance with all applicable specifications and is ready for continuous commercial operation in compliance with all applicable laws and governmental approvals. The Project has successfully passed all performance tests at a level that demonstrates satisfaction of at least the [insert minimum performance guarantees], and complete test reports have been submitted to Buyer.
2. The Operation and Maintenance Agreement (O&M Agreement), by and between Owner and _____ dated as of _____ has commenced.

3. Owner has a valid leasehold or real property interest in the Project Site for a term of at least [] years from the Commercial Operation date.
4. The interconnection facilities have been completed in accordance with applicable specifications, tariffs, laws and governmental approvals to enable power generated by the Project to be received at the Delivery Point.
5. Owner has obtained all governmental approvals necessary for the continuous commercial operation of the Project and the Project is in compliance with all such governmental approvals and all other applicable laws.

Licensed Professional Engineer certifies that:

1. We have read the Agreement, the [] Supply Contract, and the EPC Contract and we understand the requirements for Commercial Operation under the Agreement, the specifications and performance testing requirements under the [] Supply Contract, and the requirements for [Commercial Operation/Substantial Completion] under the EPC Contract.
2. We have reviewed the material and data made available to us by the Owner, the [] Supplier, and the EPC Contractor for the Project.
3. To the extent practical, we have reviewed the engineering, procurement, construction and performance testing for the Project and in the course of this review we have not discovered any material errors or omissions in the work performed to date.
4. We have reviewed the certificates of Owner, [] Supplier, and EPC Contractor above, and find the representations provided to be correct in all material respects.
5. We have reviewed all Governmental Approvals and permits identified by the Owner as being required for the construction and operation of the Project and are of the opinion that the Project as completed is in compliance in all material respects with the environmental and technical requirements contained therein.
6. Based on our review of the aforementioned information and of information provided to us by others which we have not independently verified, we are of the opinion that, as of, Commercial Operation has occurred as defined in the Agreement.

Executed this ___ day of ___, 201__

[[_____] SUPPLIER]
[Name of [_____] Supplier]
a _____ corporation

By: _____
Name:
Title:

[EPC CONTRACTOR]
[Name of EPC Contractor]
a _____ corporation

By: _____
Name:
Title:

OWNER
[Name of Owner]
a _____ limited liability company

By: _____
Name:
Title:

LICENSED PROFESSIONAL ENGINEER:
[Name of Licensed Professional Engineer]
a _____

By: _____
Name:
Title:

ACCEPTED BY SAN DIEGO GAS & ELECTRIC COMPANY

By: _____
Name: _____
Title: _____
Date: _____

Exhibit F

FORM OF QUARTERLY PROGRESS REPORT

**Quarterly Progress Report
of**

[_____]

(“Seller”)

**provided to
San Diego Gas & Electric Company**

[Date]

Table of Contents

[Insert Table of Contents]

1.0 Instructions.

All capitalized terms used in this report shall have the meanings set forth below and any capitalized terms used in this report which are not defined below shall have the meanings ascribed thereto in the Power Purchase and Sale Agreement by and between _____ (“Seller”) and San Diego Gas & Electric Company dated _____, _____ (the “Agreement”).

Seller shall review the status of each significant element of the Project schedule and Seller shall identify such matters referenced in clauses (i)-(v) below as known to Seller and which in Seller’s reasonable judgment are expected to adversely affect the Project or the Project schedule, and with respect to any such matters, shall state the actions which Seller intends to take to ensure that Conditions Precedent and the Milestones will be attained by their required dates. Such matters may include, but shall not be limited to:

(i) Any material matter or issue arising in connection with a Governmental Approval, or compliance therewith, with respect to which there is an actual or threatened dispute over the interpretation of a law or regulation, actual or threatened opposition to the granting of a necessary Governmental Approval, any organized public opposition, any action or expenditure required for compliance or obtaining approval that Seller is unwilling to take or make, or in each case which could reasonably be expected to materially threaten or prevent financing of the Project, attaining any Condition or Milestone, or obtaining any contemplated agreements with other parties which are necessary for attaining any Condition or Milestone or which otherwise reasonably could be expected to materially threaten Seller’s ability to attain any Condition or Milestone;

(ii) Any development or event in the financial markets or the independent power industry, any change in taxation or accounting standards or practices or in Seller’s business or prospects which reasonably could be expected to materially threaten financing of the Project, attainment of any Condition or Milestone or materially threaten any contemplated agreements with other parties which are necessary for attaining any Condition or Milestone or could otherwise reasonably be expected to materially threaten Seller’s ability to attain any Condition or Milestone;

(iii) A change in, or discovery by Seller of, any legal or regulatory requirement which would reasonably be expected to materially threaten Seller’s ability to attain any Condition or Milestone;

(iv) Any material change in the Seller’s schedule for initiating or completing any material aspect of Project;

(v) The status of any matter or issue identified as outstanding in any prior Quarterly Report and any material change in the Seller’s proposed actions to remedy or overcome such matter or issue.

Seller shall complete, certify, and deliver this form Quarter Quarterly Progress Report to [_____] , together with all attachments and exhibits, with [3] copies of the Report delivered to [_____] and [_____].

2.0 Executive Summary.

2.1 Major activities to be performed for each aspect of the Project during the current calendar quarter.

Please provide a brief summary of the Major² activities to be performed for each of the following aspects of the Project during the current calendar quarter:

- 2.1.1 Design
- 2.1.2 Engineering
- 2.1.3 Major Equipment procurement
- 2.1.4 Construction
- 2.1.5 Milestone report
- 2.1.6 Permitting (See Section 3.0)

2.2 Major activities scheduled to be performed in the previous calendar quarter but not completed as scheduled.

Please provide a brief summary of the Major activities which were scheduled to be performed in the previous calendar quarter and their status, including those activities that were not completed as scheduled:

- 2.2.1 Design
- 2.2.2 Engineering
- 2.2.3 Major Equipment procurement
- 2.2.4 Construction
- 2.2.5 Milestone report
- 2.2.6 Permitting

² For Purposes of this Report, "Major" shall mean any activity, event, or occurrence which may have a material adverse impact on the construction of the Facility or completion of the Project on a timely basis if such activity, event, or occurrence occurs or if such activity, event, or occurrence fails to occur as anticipated or scheduled, which material adverse impact includes, but is not limited to, Seller's inability to achieve a Milestone Date.

3.0 Permitting.

The following describes each of the major Governmental Approvals required for the construction of the Project and the status of each:

3.1 State and/or federal Governmental Approvals.

Please describe each of the Major state and/or federal Governmental Approval (including the Permit to Construct issued by the San Diego County Air Pollution Control District) to be obtained by Seller (or EPC Contractor) and the status of each.

DESCRIPTION	STATUS

3.2 Local and/or county Governmental Approvals.

Please describe each of the Major local and/or county Governmental Approvals to be obtained by Seller and the status of each.

DESCRIPTION	STATUS

3.3 Permitting activities which occurred during the previous calendar quarter.

Please list all permitting activities which occurred during the previous calendar quarter.

3.4 Permitting activities occurring during the current calendar quarter.

Please list all permitting activities which are expected to occur during the current calendar quarter.

3.5 Permitting Notices received from EPC Contractor.

Please attach to this Quarterly Progress Report copies of any notices related to permitting activities received from EPC Contractor during the previous calendar quarter.

4.0 Design Activities.

4.1 Table of design schedule to be followed by Seller and its subcontractors.

The following table lists the design schedule to be followed by Seller and its subcontractors.

ACTIVITY	CONTRACTOR/ SUBCONTRACTOR	SCHEDULED COMPLETION DATE	ACTUAL COMPLETION DATE

4.2 Design activities to be performed during the current calendar quarter.

Please explain in detail the design activities which are expected to be performed during the current calendar quarter.

4.3 Table of design activities completed during the previous calendar quarter.

Please explain in detail the design activities which were completed during the previous calendar quarter.

5.0 Engineering Activities.

5.1 Table of engineering schedule to be followed by Seller and its subcontractors.

The following table lists the engineering schedule to be followed by Seller and its subcontractors:

ACTIVITY	CONTRACTOR/ SUBCONTRACTOR	SCHEDULED COMPLETION DATE	ACTUAL COMPLETION DATE

5.2 Engineering activities to be performed during the current calendar quarter.

Please explain in detail the engineering activities which are expected to be performed during the current calendar quarter.

5.3 Engineering activities completed during the previous calendar month.

Please explain in detail the engineering activities which were completed during the previous calendar quarter.

5.4 Three-month look-ahead engineering schedule.

Please provide a three-month look ahead engineering schedule.

6.0 Major Equipment Procurement.

6.1 Table of major equipment to be procured by Seller and its subcontractors.

The following table lists major equipment to be procured by Seller and its subcontractors:

EQUIPMENT DESCRIPTION	MANUFACTURER	MODEL	CONTRACTED DELIVERY DATE	ACTUAL DELIVERY DATE	PROJECTED INSTALLATION DATE	ACTUAL INSTALLATION DATE

6.2 Major Equipment procurement activities to be performed during the current calendar quarter.

Please explain in detail the major equipment procurement activities which are expected to be performed during the current calendar quarter.

6.3 Major Equipment procurement activities completed during the previous calendar quarter.

Please explain in detail the major equipment procurement activities which were completed during the previous calendar quarter.

7.0 Construction Activities.

7.1 Table of construction activities to be performed by Seller and its subcontractors.

The following tables lists construction activities to be performed by Seller and its subcontractors:

ACTIVITY	CONTRACTOR/ SUBCONTRACTOR	SCHEDULED COMPLETION DATE	ACTUAL COMPLETION DATE
Civil Progress			
Structural Progress			
[Steam] Generator Progress			
Piping Progress			
IC and Electrical Progress			
Subcontractor Progress			

7.2 Construction activities to be performed during the current calendar quarter.

Please explain in detail the construction activities which are expected to be performed during the current calendar quarter.

7.3 Construction activities completed during the previous calendar quarter.

Please explain in detail the construction activities which are expected to be performed during the previous calendar quarter.

7.4 EPC Contractor Monthly Progress Report.

Please attach a copy of the Monthly Progress Reports received during the previous calendar quarter from the EPC Contractor pursuant to the EPC Contract, certified by the EPC Contractor as being true and correct as of the date issued.

7.5 Three-month look-ahead construction schedule.

Please provide a three-month look ahead construction schedule.

8.0 Milestones.

8.1 Milestone schedule.

Please state the status and progress of each Milestone and identify any completed Milestone(s) for the previous calendar quarter.

8.2 Remedial Action Plan (applicable if Seller fails to achieve Milestone by the Milestone Date).

Please explain in detail each of the following aspects of Seller's remedial action plan:

8.2.1 Missed Milestone

8.2.2 Plans to achieve missed Milestone

8.2.3 Plans to achieve subsequent Milestone

8.2.4 Delays in engineering schedule

Please explain in detail any delays beyond the scheduled Milestone Dates stated in Section 5.1, any impact from the delays on the engineering schedule, and Seller's plans to remedy such impact.

8.2.5 Delays in Major Equipment procurement

Please explain in detail any delays beyond the contracted delivery date and/or the projected installation date stated in Section 6.1, any impact from the delays on Major Equipment procurement schedule, and Seller's plans to remedy such impact.

8.2.6 Delays in construction schedule

Please explain in detail any delays beyond the scheduled completion dates stated in Section 7.1, any impact from the delays on the construction schedule, and Seller's plans to remedy such impact.

9.0 Safety and Health Reports

9.1 Please list all accidents from the previous calendar quarter:

9.2 Any work stoppage from the previous calendar quarter:

9.3 Work stoppage impact on construction of the Project:

I, _____, on behalf of and as an authorized representative of, do hereby certify that any and all information contained in the attached Seller's Quarterly Progress Report is true and accurate, and reflects, to the best of my knowledge, the current status of the construction of the Project as of the date specified below.

By: _____

Name: _____

Title: _____

Date: _____

RPS Project Development Status Report

**Project Name
Date**

Date of Latest Construction Progress Report from Counterparty:

Project Owner/Counterparty:

Technology:

Capacity (MW):

Annual Energy (GWh/year):

On-Line Date:

Term/Duration (years):

Construction Start Date:

Point of Delivery:

Location:

Status At-A-Glance

The below to be filled in w/ either: Completed, Acceptable, Unknown, or Concern. See Section B for a description of milestones. When the answer is "Concern" the milestone should be flagged with a notation number where additional detail is provided in Section A.

Milestones	Status	Initial Completion Date	Projected Completion Date
Fuel/Resource Supply:			
Financing:			
Corporate Financing			
Project Financing			
Site Control (100%):			
Permitting:			
Engineering:			
Major Equipment Procurement:			
Construction:			
Startup Testing and Commissioning:			
Transmission:			

Transmission - Detail (see Section C)

Dependent Transmission Upgrade(s):

Scheduled Completion:

Point of Interconnection:

Early Interconnection:

Gen-Tie Length:

Gen-Tie Voltage:

ISO Queue Position:

Feasibility Study (FS):

System Impact Study (SIS):

Facilities Study (FAS):

Remedial Action Plan:

Additional Comments:

Date of Preparation:

Exhibit G

OUTAGE NOTIFICATION FORM

OUTAGE NOTIFICATION FORM

This form may be used to comply with CAISO's outage notification requirements for both planned and forced outages. Report outages as soon as possible by submitting form via email to TSched@SemptraUtilities.com or via fax at (858) 650-6191.

Request Type:

New Scheduled Maintenance Outage ▼

Previous Notification (if applicable)

Date Sent: mm/dd/yyyy
Time Sent: hh:mm

Generator Name: _____
Location Code: _____
Address: _____

(For times, use 24hr format)

Today's Date: mm/dd/yyyy
Current Time: hh:mm

Contact Name: _____
Phone Number: _____
Email: _____

Outage Start Date: mm/dd/yyyy
Outage Start Time: hh:mm

Outage End Date: mm/dd/yyyy
Outage End Time: hh:mm

Alternate Name: _____
Alternate Number: _____
Email: _____

Outage Duration: _____
MW Available During Outage: _____
MW Unavailable During Outage: _____
RMR Unit? Yes/No

System (Select One)

- Boiler
Codes 0010-1999
- Generator
Codes 4500-4899
- Regulatory, Safety, Environmental
Codes 9504-9720
- Balance of Plant
Codes 3110-3999
- Pollution Control Equipment
Codes 8000-8835
- Others
Codes 9900-9999
- Steam Turbine
Codes 4000-4499
- External
Codes 9000-9040

Cause Code Ranges / Affected Component

(Select One) ▼

Cause Code / Component Problem

(Select One) ▼

Comments

