



ARC WELDING PROCEDURE REQUIREMENT ALL STRESS LEVELS

D-22

Asset Type: Gas Transmission and Distribution

Function: Design and Construction

Issued by: [REDACTED]

Original Signed By [REDACTED]

Date: 04-29-09

Rev. #05: This document replaces Revision #04. For a description of the changes, see Page 14.

This document also appears in the following manual:

- *Gas Applicant Design Manual*

Purpose and Scope

This numbered document shall be included as a part of all welding procedure specifications used on natural gas facilities governed by 49 CFR Part 192 (latest revision), Subpart E, and API 1104. Changes or deviations to these welding standards shall be approved by the responsible engineer following consultation with the welding specialist.

Acronyms

API:	American Petroleum Institute
ASME:	American Society of Mechanical Engineers
ASTM:	American Society for Testing and Materials
ATS:	Applied Technology Services
AWS:	American Welding Society
CE:	carbon equivalent
CFR:	<i>Code of Federal Regulations</i>
dc:	direct current
FCAW:	flux cored arc welding
GIS:	Geographic Information System
GMAW:	gas metal arc welding
GTAW:	gas tungsten arc welding
GT&D:	Gas Transmission and Distribution
MAOP:	maximum allowable operating pressure
OD:	outside diameter
psi:	pounds per square inch
psig:	pounds per square inch gauge
SAW:	submerged arc welding
SMAW:	shielded metal arc welding
SMYS:	specified minimum yield strength
WPS:	Weld Procedure Specification

References

	Document
Drain Tube on 2" to 6" Pipelines and Sample Tube on All Pipeline Sizes	A-32
Drain Tube Installation for 8" to 34" Pipelines in Service	A-32.1
Gas Main Welding Sleeves (Type B Sleeves With Circumferential Welds)	A-60
In-Service Welding	D-23
Direct Deposition Welding	D-23.1
Welder Qualification for Under 20% of SMYS	D-30
Arc Welder Qualification for Working on Pipelines That Operate at Over 20% of SMYS	D-30.2
Weld Inspection	D-40
Welding of Pipelines and Related Facilities	API 1104

Arc Welding Procedure Requirement All Stress Levels

Welding Specifications

1. Materials to be welded using the procedures in this numbered document include the following. Any exceptions shall be noted in the particular welding procedure specification.
 - API 5L, Grade B up to and including X-70
 - ASTM A-53, Grade B
 - ASTM A-106, Grade B
 - ASTM A-516, Grade 70 (38,000 psi yield)
 - ASTM A-242 (50,000 psi yield)
 - ASTM A-633, Grade E (60,000 psi yield)
 - ASTM A-234, Grade WPB
 - ASTM A-105 (35,000 psi yield)
 - ASTM A-572 (50,000 psi yield)
2. All welding on pipe and fittings shall be completed using detailed procedure specifications established, qualified, and recorded in accordance with 49 CFR Part 192 and API 1104.
3. Weld Procedure Selection
 - A. Before welding pipe or fittings, the welder must first identify the pipe size, the type of material to be welded, the SMYS, and the stress level at which the pipe is designed to operate. The maximum hoop stress permitted, the appropriate welding process, and the procedure shall be determined from Items 3B through 3E below.
 - B. All piping, fittings, and appurtenances designed to operate above 60 psi or 20% SMYS, regardless of size, shall be welded by using one, or a combination of, the following processes:
 - SMAW (See Numbered Document D-30.2 for qualification procedure)
 - GMAW
 - FCAW
 - GTAW
 - SAW
 - C. This numbered document covers the SMAW process using cellulose and low-hydrogen electrodes and the GMAW process for all stress levels.
 - D. SMAW and GMAW shall be the preferred welding processes used for all piping larger than 2" nominal diameter, with a wall thickness greater than 0.154", and designed to be operated above 60 psi or 20% SMYS.
 - E. Piping designed to operate at less than or equal to 60 psi may be welded using any of the arc welding processes listed in Item 3B above.
 - F. GMAW is the preferred process for making branch-connection welds on piping designed to operate above 60 psi or 20% SMYS. If the SMAW process is performed to weld branch connections, cellulose electrodes can be used for the first and second passes, followed by low-hydrogen electrodes for the filler and cover passes.
 - G. When performing a circumferential welding on pipe greater than 12" in diameter (nominal), a minimum of two welders shall work simultaneously on opposite sides of the pipe.
 - H. Before welding, ensure that there are no liquids in the segment of the pipeline to be welded. If liquids are suspected, take one of the following steps:
 - (1) Remove liquid using an existing drain.
 - (2) Install a drain per Numbered Document A-32 or A-32.1, and remove the liquid.
 - (3) Perform in-service welding as described in Numbered Document D-23.
 - I. The maximum hoop stress permitted when welding on pressurized piping shall be determined as follows:
 - (1) When applicable, welding may be performed with no reduction of operating pressure in accordance with Numbered Documents D-23 and D-23.1.

Arc Welding Procedure Requirement All Stress Levels

- (2) If in-service welding is not the preferred choice or is not applicable, evaluate the operating pressure before welding. The maximum operating pressure permitted during welding is the least pressure given in Items 3I(2)(a), 3I(2)(b), and 3I(2)(c) below.

The maximum pressures are also shown on the Gas Transmission GIS. Where the condition of the pipe is found to be poor, or where other conditions exist which could cause problems while welding, it may be necessary to lower the operating pressure. This lower pressure should be determined based on evaluating the observed condition of the pipe and by good engineering judgment.

- (a) For seamless and double-submerged arc welded pipe, the maximum pressure permitted during welding shall be determined using the formula given below, the MAOP, or a pressure which will produce a hoop stress of 50% of the SMYS, whichever is lowest.

$$P = \frac{2S \times (t - 0.094) \times 0.72}{D}$$

where,

P = internal pressure, psig
 S = specified minimum yield strength, psi
 t = nominal pipe wall thickness, inches
 D = outside pipe diameter, inches

For all other pipe, the maximum pressure permitted during welding shall be determined using the formula given above, the MAOP, or a pressure which will produce a hoop stress of 40% of the SMYS, whichever is lowest.

- (b) The maximum hoop stress permitted during welding shall not exceed 20% of the SMYS when:

- Welding within 3" of the longitudinal seam, the circumferential, and any branch weld on any type of pipe (except the longitudinal seam of double-submerged arc welded pipe).
- Welding within 3" of any defect (gouges, corrosion, laminations, etc.) in the pipe which exceeds 1/3 of the nominal wall thickness in depth and/or 1/4 of the nominal pipe diameter in length. Any number of closely spaced adjacent defects shall be treated as one defect of a size and depth encompassing all the defects.
- More than one weld repair is required in any length equal to five pipe diameters or 5', whichever is less.

- (c) Preheating above 450°F, or high-temperature stress relieving, is not permitted on pipelines under pressure. The yield point and fracture sensitivity of non-expanded, high-strength pipe are adversely affected when pipe is heated above 600°F, unless it is heated and cooled under controlled conditions. The yield point of expanded pipe is permanently lowered by approximately 20% when it is heated above this temperature.

J. Low-hydrogen electrodes or GMAW shall be used, if the line flow cannot be made static, or if the temperature of the pipe is less than 50°F, and operates above 60 psi.

4. Weld Preparation

- A. Welding electrodes shall conform to AWS Specifications A-5.1, A-5.5, or A-5.18. Refer to the "Welding With Cellulose-Coated and Wire Electrodes" section on Page 10, Table 3 on Page 10, Table 4 on Page 11, Figure 9 and Figure 10 on Page 11, the "Welding With Low-Hydrogen Electrodes" section on Page 12, and Figure 11 and Figure 12 on Page 12.
- B. The welding operation must be protected (shielded) from any weather conditions (rain, snow, ice, or high winds) that would impair the quality of the completed weld.
- C. Before welding, the weld groove and the adjacent surfaces up to 1" around it shall be cleaned and kept free of all dirt, paint, rust, scale, moisture, oil, grease, or other foreign material harmful to welding. Clean by filing, hand or power wire brushing or grinding, and/or by using approved solvents. Alcohol (methanol or ethanol) or acetone are acceptable solvents for cleaning and drying. Do not expose these solvents or their fumes to open flame, arcs, or hot surfaces.
- D. Before sections of pipe and fittings are assembled for welding, all rust, scale, slag, dirt, liquids, or other foreign matter shall be removed from the inside surface of the pipe by swabbing with clean rags or by other

**Arc Welding Procedure Requirement
All Stress Levels**

acceptable methods. The responsible person (people) on the job shall ensure compliance with this requirement.

- E. Pipe and/or fittings joined by welding shall be aligned to minimize any offset (high or low) of the pipe wall surfaces around the circumference of the pipe. For joining pipe and/or fittings of the same nominal wall thickness, the internal offset should not exceed 1/8". Internal offset greater than this dimension is permissible provided the pipe end dimension is within the tolerances contained in the material specification and is distributed evenly around the circumference of the pipe. If the pipe or fitting ends are defective or damaged (scratches, gouges, dents, etc.), the ends shall be rebeveled. For joining pipe of unequal wall thickness, the internal offset shall not exceed 3/32". If this value is exceeded, refer to Figure 2 through Figure 8 on Page 9 of this numbered document. The external offset shall be limited to the out-of-roundness and the pipe and fitting end-diameter tolerances given in the material specifications.
- F. All hammers used for aligning pipe and fittings must be bronze or brass faced. Avoid denting, gouging, or scratching the pipe and/or fittings.
- G. When aligning abutting lengths of the pipe for welding, the longitudinal seams shall be staggered (no closer than 3") within the top quadrant (10 to 2 o'clock).
- H. A lineup clamp shall be used on pipe with a nominal diameter 3" or larger. It is recommended that the lineup clamp be left in place until the root pass is at least 50% completed and equally deposited around the weld groove. No stress (movement) shall be placed on the weld groove until the root pass and second pass are completed.
- I. The minimum separation between any two circumferential welds, wherever possible, shall be as follows:
 - (1) One pipe diameter for welds on pipelines and station piping but never less than 3" (except as allowed by Item (2) below).
 - (2) 1", as measured along the inside arc radius of any welding elbow and the transverse segments of this elbow for 2" or more in nominal diameter. See 49 CFR 192.313(c).
 - (3) Branch-connection welds, including reinforcing member welds, shall be located at least 3" away from circumferential welds whenever possible.
- J. To perform work safely, adequate working clearance shall be provided and maintained around the pipe and/or fittings at all points to be welded.
- K. When cutting or welding near fittings containing rubber stoppers, it is recommended that the minimum distance between the face of the stopper and the cutting or welding operation be as indicated in Table 1 below.

Table 1 Minimum Distance Between Stopper and Weld or Cut

Pipe Size (Inches)	Minimum Distance Between Stopper and Weld or Cut ¹ (Inches)
3/4	6
1	6
1-1/4	6
1-1/2	7
2	8
2-1/2	9
3	10
4	12
6	14
8	16
10	18
12 and larger	20

¹ In those cases where it is not possible to maintain the recommended minimum distance between the stopper face and the cutting or welding operation, some auxiliary cooling means such as wet burlap or wet rags should be placed around the fitting to reduce the temperature.

Arc Welding Procedure Requirement All Stress Levels

5. Preheating

A. Preheating of 200°F minimum to 400°F maximum must be achieved and maintained at the weld location until the completion of welding when any of the following conditions exist:

- (1) When the pipe or fitting wall thickness (regardless of pipe grade) is greater than 0.5".
- (2) When welding on pressurized pipe with the MAOP above 60 psi pressure.
- (3) When the pipe mill heat analysis shows a carbon content in excess of 0.32%.
- (4) When CE exceeds 0.65% (CE% = carbon % + 1/4 manganese %).

Pipe material meeting API Specification 5L and ASTM A-53 or A-106, Grade B specifications, does not exceed the chemical limits required for preheating that are shown above. Certain fitting materials may exceed the limits and therefore would require preheating.

- (5) When specified by the WPS.

B. The preheated area shall be at least 6" wide around all points where weld metal will be deposited.

C. The preheat temperature shall be checked at the weld area outside of the weld groove using temperature-sensitive crayons, such as "Tempilsticks", or a contact pyrometer.

D. If welding is interrupted, the weld area shall be preheated again before welding is resumed.

E. The interpass temperature is the temperature of the weld area between each deposit of weld beads. The minimum interpass temperature shall comply with the minimum preheat temperature requirements.

6. Stress Relieving

A. Stress relieving shall be required under the following conditions:

- (1) When the carbon content of the pipe fitting material, as determined by heat analysis, exceeds 0.32% or the CE exceeds 0.65%. (Pipe meeting API Specification 5L and ASTM A-53 or A-106, Grade B specifications, does not exceed these limits. Certain fitting materials may exceed these limits and therefore require stress relieving.)
- (2) When the wall thickness of the pipe or fitting being welded is 0.750" or greater, unless low-hydrogen or GMAW welding processes are used. Stress relieving is mandatory for all thickness 1-1/4" or greater.
- (3) When couplings, weldolets, or socket-weld fittings larger than 2" are welded to a header wall with a thickness 0.750" or greater, unless low-hydrogen or GMAW welding processes are used. Stress relieving is mandatory for all header wall thickness 1-1/4" or greater.

B. Stress-Relieving Temperature

- (1) For welding being performed under API specifications as in this numbered document, heat uniformly to achieve stress-relieving temperatures at a rate suitable to the type of equipment being used. When welding to ASME specifications, heat uniformly at a rate not to exceed 600°F per hour, while the temperature is below 600°F, and not to exceed 400°F per hour when above 600°F.
- (2) The weld being stress relieved shall be held in the range of 1,100°F to 1,200°F for a period of 1 hour per inch of wall thickness, but in no case less than 45 minutes.
- (3) After stress relieving is completed, the weld shall be cooled to 600°F at a cooling rate not to exceed 500°F per hour. For 600°F and below, the weld may be cooled in still air. Accelerated cooling is not allowed.
- (4) The minimum width of the area on each side of the weld that will be stress relieved shall be equal to four times the wall thickness, or 2", whichever is greater.

C. Equipment for Local Stress Relieving

- (1) Stress relieving may be accomplished by electric induction, electric resistance, or other suitable means of heating in compliance with Item 6B above.
- (2) The stress-relieving temperature shall be checked with recording, thermocouple pyrometers. The recording charts shall be properly identified and kept as part of the job records.

Arc Welding Procedure Requirement All Stress Levels

7. Horizontal and Vertical Fixed-Position Welding; Cellulose-Type Electrode or Wire-Type Electrode for GMAW

Horizontal and vertical, fixed-position, shielded, metal-arc welding with cellulose-covered electrodes (AWS E6010, E7010, or E8010) or wire electrodes (ER70S-6) shall be performed using the "downhill" method. Refer to Figure 10 on Page 11 for the proper electrode to use with specific materials.

A. Root Pass and Hot Pass (Second Pass)

- (1) The amount of root opening (gap) for the welding process used shall fall within the range given in Figure 9 on Page 11 and should suit the preference of the welder responsible for the integrity of the root pass. During alignment and tacking, hold the joint together by a lineup clamp. Ensure full penetration and complete fusion during tacking and the root pass.
- (2) Strike the arc in the weld groove only. Make the stringer bead for SMAW by using a drag technique (the electrode coating resting on the bevel as the electrode is dragged downhill). Thoroughly clean the stringer before applying the hot pass (second pass). Use disc grinding to remove bumpy starts and slag, improve the bead contour, or remove excessive wagon tracks (see Figure 1 below) before applying the hot pass (second pass).

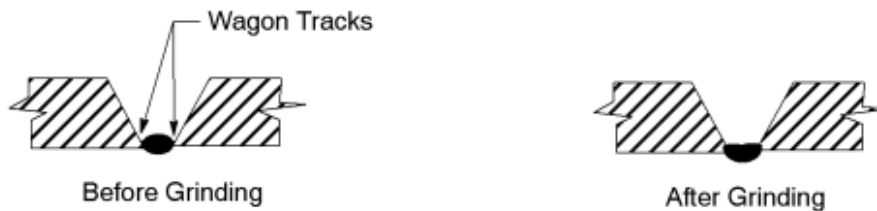


Figure 1
Wagon Tracks – Slag-Filled Crevices on Either Side of Root Pass

- (3) When applying the hot pass with SMAW, sufficient heat (amperage) will be needed to melt out shallow wagon tracks and float any remaining slag to the surface. Use a slight up-and-down whipping motion. Start the hot pass immediately after completion of the root pass (within 5 minutes).

B. Filler and Cover Passes

- (1) Use a side-to-side weave motion when applying the filler passes. Filler metal shall be added to any concave portion of the groove, before applying the cover pass.
- (2) On heavy wall pipe and fittings with a wide welding groove, more than one bead per layer shall be used for filling in the downhill direction.
- (3) Strip capping shall be used for the cover pass when welding in the vertical, fixed position. Wash passes are not acceptable when welding in this position.
- (4) Filler and cover passes made using the weave motion when welding downhill on horizontally fixed pipe and fittings shall be no wider than four times the electrode diameter for SMAW and 3/4" for GMAW. Welds shall be uniform and without undercutting.
- (5) The face of the completed weld should be approximately 1/8" greater than the width of the original groove. At no point shall the crown surface be below the outside surface of the pipe, nor should it be raised above the parent metal more than 3/32".
- (6) The completed weld shall be thoroughly brushed and cleaned.

8. Horizontal and Vertical, Fixed-Position Welding – Low-Hydrogen Electrodes (see Item 4 on Page 12 for recommended use)

- A. To perform properly, low-hydrogen electrodes must be stored and handled in a manner which will prevent the absorption of moisture. They shall either be stored in the manufacturer's hermetically sealed, unopened containers, or in holding ovens if the containers have been opened. Electrodes in unopened sealed containers remain dry indefinitely under good storage conditions. The storage area should be enclosed, clean, dry, and have adequate facilities for safe storage to prevent deterioration.
- B. If used immediately, low-hydrogen electrodes may be taken directly from freshly opened, hermetically sealed containers. The remaining electrodes shall be removed from the containers and placed in an electric holding oven or portable rod warmer and held at a temperature of 250°F to 350°F.

Arc Welding Procedure Requirement All Stress Levels

- C. Electrodes shall be withdrawn from the holding oven or portable rod warmer in small quantities and used immediately.
- D. The electric holding oven or portable rod warmer shall be powered by a reliable electric source.
- E. Electrodes shall not be exposed to moisture. They shall not be used after having been removed from their sealed containers or holding oven for a period exceeding 4 hours.
- F. Electrodes subjected to the conditions described in Item 8E must be dried or discarded. Dry electrodes by baking them in an electric oven at 700°F to 800°F for a minimum of 1 hour. Transfer them to a holding oven and hold them there until used. Discard any electrodes if the coating becomes fragile. Discard any electrodes that flake or break off while welding, or that develop a noticeable difference in handling or arc characteristics.
- G. Qualified welders using low-hydrogen electrodes shall be thoroughly instructed in storage and handling requirements and be issued an electric heater or portable electrode warmer. Low-hydrogen electrodes shall always be issued in portable rod warmers, or the electrodes shall be returned to the heated storage oven within the time specified in Item 8E.
- H. Welding Technique With Low-Hydrogen Electrodes (refer to Figure 11 through Figure 20 on Pages 12 and 13)
- (1) On horizontally fixed pipe and fittings, the root pass and hot pass shall be made by welding downhill, using shielded metal-arc welding with E6010(5P), E7010(HYP+), or E8010(70+) electrodes.
 - (2) On horizontally fixed pipe and fittings, filler and cover passes shall be made by welding uphill using E7016 or E7018 electrodes for all grades of pipe through X-60, and E8016 or E8018 electrodes for X-65 and X-70 pipe. See specific WPS.
 - (3) On heavy wall pipe or fittings (greater than Schedule 40) with a wide welding groove, use more than one filler and/or cover pass per layer.
 - (4) Filler and cover passes made by welding uphill using the weave motion on horizontally fixed pipe and fittings shall be no wider than 5/8" if using a 3/32" diameter rod and 3/4" if using a 1/8" diameter rod.
 - (5) On pipe or fittings in the vertically fixed position, each weld layer shall be deposited with multiple passes in the horizontal plane when the weld groove is three times the electrode diameter. Large weave passes shall not be permitted.
 - (6) On vertically fixed pipe and fittings, the root pass and hot pass shall be made by using SMAW with E6010(5P), E7010(HYP+), or E8010(70+) electrodes.

9. Roll Welding

For roll or flat welding, the welding arc is struck on the top of the pipe or fitting and held there to deposit the bead as the pipe or fitting is steadily revolved. When applicable, roll welding will be permitted, providing alignment and support are maintained.

10. Fillet Weld

The bead shape of all fillet welds shall be flat or slightly convex, and the length of each weld leg shall be equal. All attachments using fillet welds shall be made in accordance with Figure 13 through Figure 20 on Page 13 of this numbered document.

- A. When welding slip-on flanges to pipe, the inside weld joining the pipe end to the flange's inside-diameter bore surface shall be completed first, followed by the weld at the outside of the flange to the outside circumference of the pipe, as shown in Figure 16 on Page 13.
- B. Fillet welds to attach supports and other non-pressure attachments to pressure piping must be designed and approved by the responsible pipeline engineer.

11. Back Welding

- A. Back welding and end preparation when joining unequal wall thicknesses shall be performed as specified on Page 9 of this numbered document. Before back welding, disc grind or wire buff any loose scale from the backside of the weld groove.
- B. When 16" and larger diameter valves and fittings are welded to each other or to pipe, the joint shall have a two-pass weld on the inside as well as the outside weld, if the internal misalignment exceeds 3/32". This requirement also applies to smaller diameter valves and fittings when it is practical. Back welding is not required if the valves and fittings are supplied already shop welded to pipe of the same wall thickness as the line pipe.

Arc Welding Procedure Requirement All Stress Levels

C. Back welding shall be done using SMAW with E6010, E7010, or E8010 electrodes. Use a small weave to penetrate and fuse the backside of the weld groove. The bead width and height should exceed the minimum requirements shown in Figure 2 through Figure 8 on Page 9 by as small a margin as practical. If a second fill pass is needed, this pass should form a smooth transition from one side of the pipe to the other. Do not overweld.

12. Repair or Removal of Defects and Cracks

A. Preheating the segment(s) to be repaired is required if conditions exist which would adversely affect the quality of the weld repair. Post-weld heat treatment and nondestructive examination shall be the same as that required for the original weld joint.

B. If a section of pipe has arc burns that are repaired by grinding, the remaining wall thickness must at least be equal to either:

- (1) The nominal wall thickness required for the design pressure of the pipeline, or
- (2) The minimum wall thickness required by the tolerance in the specification to which the pipe was manufactured. The amount of allowable wall thickness reduction based on the manufactured pipe specifications is as follows:
 - 12-1/2% for ASTM A-106 pipe
 - 10% for API-5L pipe
 - 8% for API-5LX pipe
 - 12-1/2% for ASTM A-53 pipe
- (3) Alternate acceptance criteria to establish the minimum required remaining wall thickness may be applicable (such as RSTRENG), but must be approved by GT&D gas engineering personnel.

C. Grinding and fill welding

- (1) A facility engineer or a pipeline engineer is responsible for having a written weld repair procedure prepared when grinding and fill welding is to be used for any of the following conditions:
 - (a) Repair of cracks.
 - (b) Any defect in a previously repaired area for new construction.
 - (c) All repairs on existing pipelines.
- (2) If the repair is to be performed on a pressurized pipeline with an MAOP above 60 psi refer to Numbered Documents D-23 and D-23.1.
- (3) Areas to be repaired shall be thoroughly cleaned and prepared in accordance with the requirements given in this numbered document before grinding or welding.
- (4) Cracks in circumferential or branch-connection welds that exceed 8% of the total weld length and cracks in original pipe longitudinal seam welds may not be repaired using grinding and fill welding.
- (5) Oxy-fuel gas gouging (flame gouging), air carbon-arc gouging, grinding, and chipping are acceptable methods for removing cracks and other defects. However, only grinding or chipping may be used on pressurized lines.
- (6) After removing any cracks, the repair groove must be examined by a magnetic particle test to ensure complete removal of the cracks (per requirements of Numbered Document D-40).
- (7) After removing any defects other than cracks, the area shall be visually examined to verify that the defects have been completely removed.
- (8) Weld metal shall be deposited to restore the original material contour. The surface of the finished repair shall be ground smooth to the contour of the pipe on all lines operating over 100 psig.
- (9) The completed repair shall be inspected per the requirements of Numbered Document D-40.

13. Identifying Welds

Where the number of welders makes identifying an individual welder's work difficult, welders shall identify their work by using a paint pen or other suitable marker to apply an assigned number or initials.

Arc Welding Procedure Requirement All Stress Levels

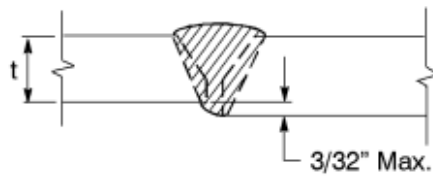


Figure 2

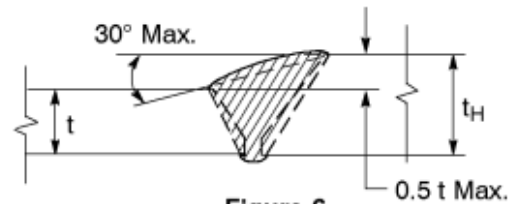


Figure 6

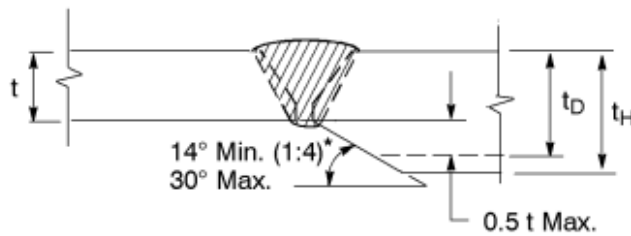


Figure 3

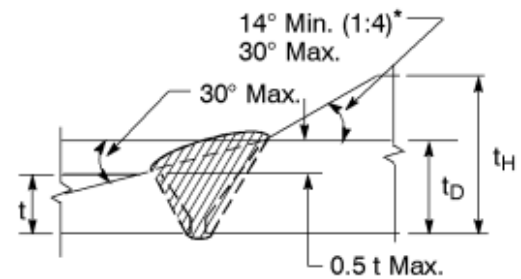


Figure 7

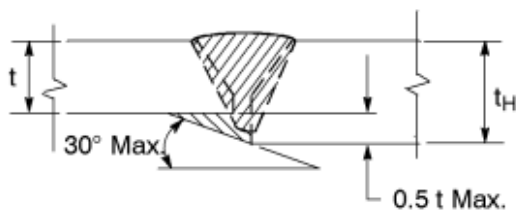


Figure 4

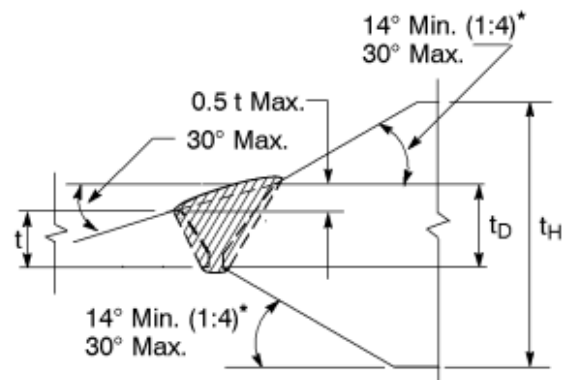


Figure 8

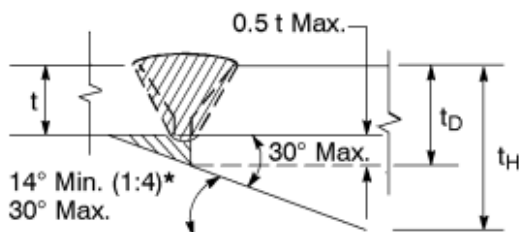


Figure 5

Notes

1. The joint design shown in Figure 3 shall not be used where a thicker pipe wall has a lower yield strength. A joint of this type can be used where the location class changes.
2. If the materials being joined have different yield strengths, the welding electrodes used must be suitable for the highest yield material in each joint.
3. A legend of values and symbols used in Figure 3 through Figure 8 is shown as follows:
 - t_D – The required wall thickness designed for heavy wall pipe which is being joined to thinner pipe. The t_D value may not exceed $1.5 t$.
 - t_H – The actual wall thickness of the heavier wall pipe.
 - * – No minimum when joined materials have equal yield strength.

Arc Welding Procedure Requirement All Stress Levels

Welding With Cellulose-Coated and Wire Electrodes

1. All current used shall be as specified in the applicable WPS.
2. If back welding, use "hot pass" techniques for the first back-weld pass. Use conventional filler and cover techniques if multiple passes are required.
3. In some older pipeline installations, "PG&E Specified" pipe was installed. This pipe does not necessarily comply with API, ASTM, or any other pipeline standard. Before welding on "PG&E Specified" pipe, consult GT&D gas engineering personnel for the proper welding procedures and electrodes to use.
4. When welding fittings in pipelines, and there is more than one suitable electrode given in Table 3, use the higher-strength electrodes (i.e., E7010 instead of E6010, or E8010 instead of E7010).

Table 2 Codes for the Cellulose-Coated and Wire Electrodes

Electrodes	Code
3/32", E6010, Fleetweld 5P or Equal	159252
1/8", E6010, Fleetweld 5P or Equal	159026
5/32", E6010, Fleetweld 5P or Equal	159027
3/16", E6010, Fleetweld or Equal	159028
1/8", E7010, Shield Arc Hyp+ or Equal	159285
5/32", E7010, Shield Arc Hyp+ or Equal	159286
3/16", E7010, Shield Arc Hyp+ or Equal	159287
1/8", E8010, Shield Arc 70+ or Equal	159405
5/32", E8010, Shield Arc 70+ or Equal	159406
3/16", E8010, Shield Arc 70+ or Equal	159407
0.035", ER70S-6, Lincoln L-56 or Equal	150075

Table 3 Electrodes Suitable for Welding Various Materials

Material		Electrode	
		AWS A-5.1 and 5.5 SMAW	AWS A-5.18 GMAW
Pipe (See Item 3 Above)	API 5L, Grade B and A-25	E6010	ER70S-6
	API 5L, Grade X-42 to X-48	E6010	ER70S-6
	API 5L, Grade X-52 to X-60	E7010	ER70S-6
	API 5L, Grade X-65	E8010	ER70S-6
	API 5L, Grade X-70	E8010	ER70S-6
Pipe (See Item 3 Above)	ASTM A-53, Grade B	E6010	ER70S-6
	ASTM A-106, Grade B	E6010	ER70S-6
Fittings	ASTM A-105	E6010	ER70S-6
	ASTM A-234, Grade WPB	E6010	ER70S-6
	ASTM A-242 and A-441	E6010	ER70S-6
	ASTM-A516, Grade 70	E6010	ER70S-6
	ASTM A-633, Grade E	E7010	ER70S-6

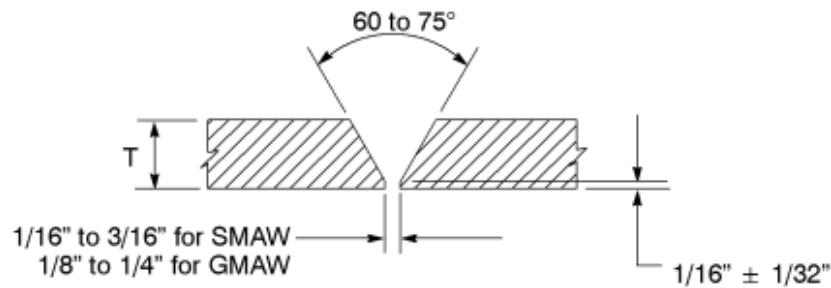
Arc Welding Procedure Requirement All Stress Levels

Table 4 Weld Detail for SMAW and GMAW With Cellulose-Coated and Wire Electrodes

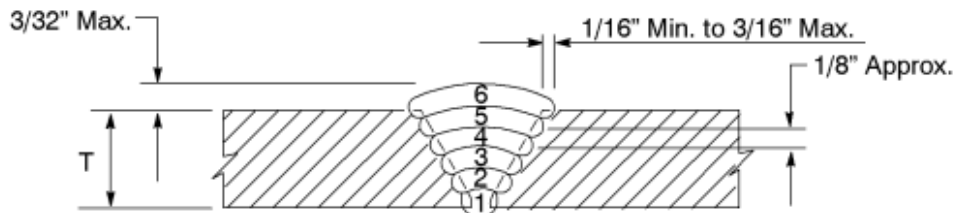
Weld Layer	Method		Electrode		Recommended	
	Horizontal Fixed Position	Vertical Fixed Position ¹	Class	Size	Amperes	Volts
First Pass	Downhill	Bead	Table 3	All	90 to 100 (GMAW) 100 to 170 (SMAW)	18 to 20 (GMAW) 26 to 28 (SMAW)
Hot Pass (See Item 2 on Page 10)	Downhill	Bead	Table 3	1/8" or 5/32"	120 to 160	24 to 28
Filler Passes	Downhill ²	Bead	Table 3	All	140 to 180	24 to 28
Cover Pass	Downhill ²	Bead	Table 3	All	140 to 180	24 to 28

¹ Large weave passes shall not be used for the vertically fixed position.

² Exceptionally wide, downhill, large weave passes are not permitted.



**Figure 9
Weld Design With Cellulose-Coated and Wire Electrodes**



Sequence of Beads (The number will vary with changes in the wall thickness, etc.)

**Figure 10
Standard V Bevel Butt Joint**

Arc Welding Procedure Requirement All Stress Levels

Welding With Low-Hydrogen Electrodes

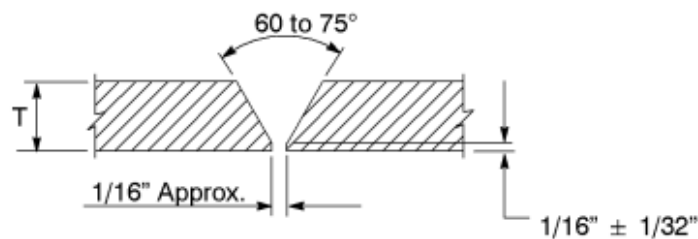
1. All current used shall be as specified in the applicable WPS.
2. The electrodes specified in Table 5 below are suitable for all API grades through X-60. For Grade X-65 and X-70, use E8016 or E8018. See specific WPS for electrodes for filler and cover passes.
3. The handling instructions and weld techniques in "Welding Specifications," Item 8 on Page 6 must be followed.
4. Low-hydrogen electrodes are recommended for high-yield, heavy wall pipe for station piping, river crossings, or other locations where vibration or external loading may occur. Contact one of the following if more information is required:
 - ATS welding services engineer
 - GT&D gas field support personnel
5. For the root pass and the hot pass, use the electrodes as shown in Table 3 on Page 10.
6. Low-hydrogen electrodes: To order the 1/8" E7018 (Alt: E7016) Hobart, Airco, Alloy Rods, or Lincoln, use Code 159194.

Table 5 Weld Detail With Low-Hydrogen Electrodes

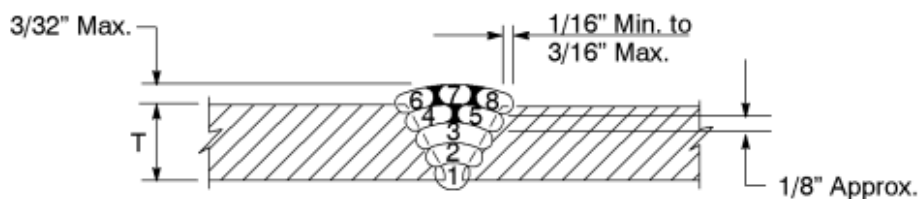
Weld Layer	Method		Electrode		Recommended	
	Horizontal Fixed Position	Vertical Fixed Position ¹	Class	Size	Amps	Volts
First Pass	Downhill	Bead	See Note 5 Above	All	100 to 170	26 to 28
Hot Pass ²	Downhill	Bead	See Note 5 Above	1/8" or 5/32"	120 to 160	24 to 28
Filler Passes	Uphill	Bead	E7016 or E7018	3/32" or 1/8"	100 to 150	22 to 25
Cover Pass	Uphill	Bead	E7016 or E7018	3/32" or 1/8"	100 to 150	22 to 25

¹ Large weave passes shall not be used for the vertically fixed position.

² If back welding, use hot-pass techniques for the first back-weld pass. Use conventional filler and cover techniques if multiple passes are required.



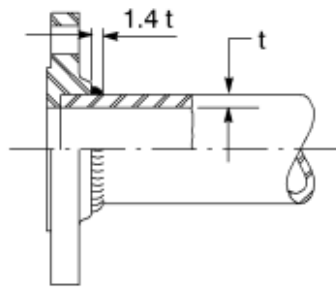
**Figure 11
Weld Design With Low-Hydrogen Electrodes**



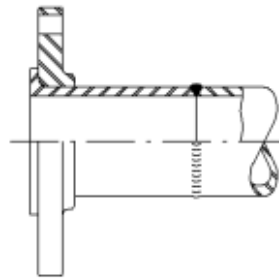
Sequence of Beads (The number and position will vary with changes in the wall thickness, etc.)

**Figure 12
Standard V Bevel Butt Joint**

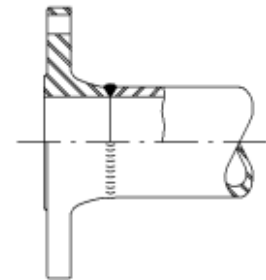
**Arc Welding Procedure Requirement
All Stress Levels**



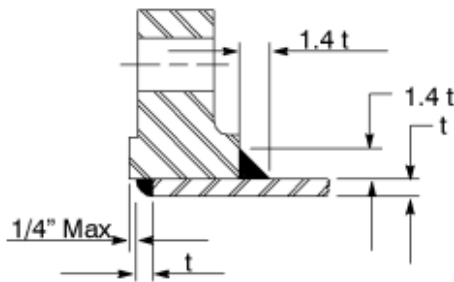
**Figure 13
Socket-Welding Flange**



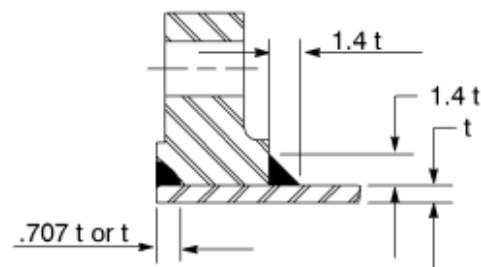
**Figure 14
Lap-Joint Flange**



**Figure 15
Butt-Welding Flange**

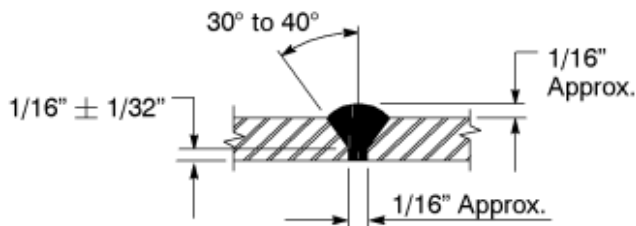


Front and Back Weld

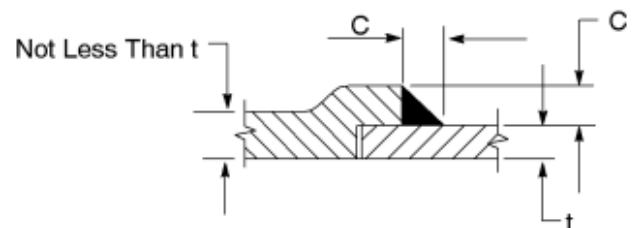


Face and Back Weld

**Figure 16
Slip-On Flanges**

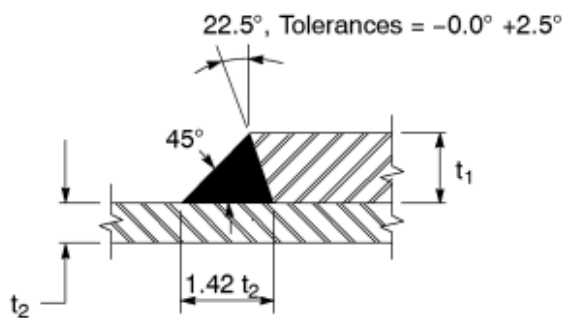


**Figure 17
Butt-Welding Joint**

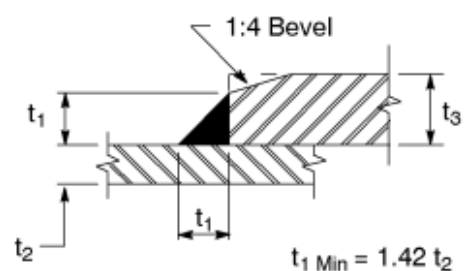


t = Wall Thickness Nominal
C Minimum = 1-1/4 t, But Not Less Than 5/32"

**Figure 18
Socket-Welding Joint**



**Figure 19
Welding Sleeve Attachments for Any Pipe Diameter
(Must be used for 18" OD and larger pipe.
Refer to Numbered Document A-60 for the weld details.)**



**Figure 20
Welding Sleeve Attachments
for 16" OD and Smaller Pipe**

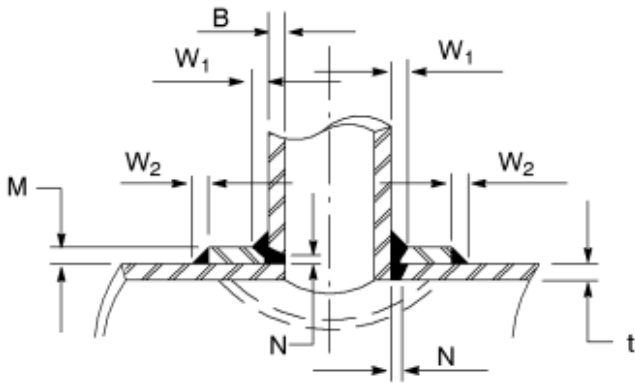
**Arc Welding Procedure Requirement
All Stress Levels**

A legend of the symbols for Figure 21 and Figure 22 are as follows:

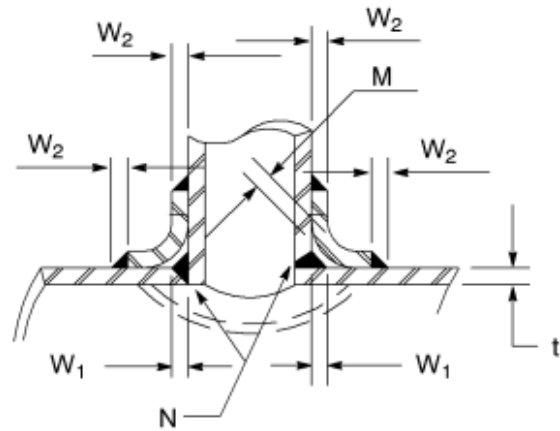
W_1 Min. = $0.375 B$, But Not Less Than $1/4"$

W_2 Min. = $0.5 M$, But Not Less Than $1/4"$ or t , Whichever is Smaller

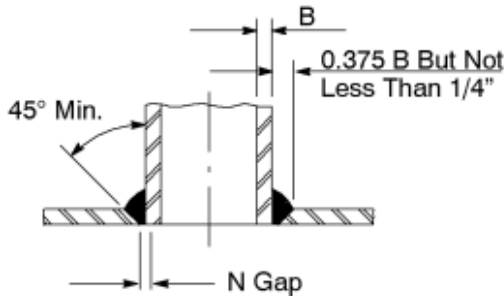
$N = 1/16"$ Min., $3/16"$ Max.



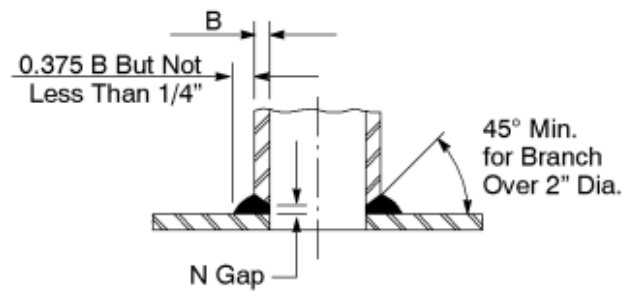
**Figure 21
Pad-Type Reinforcement**



**Figure 22
Saddle-Type Reinforcement**



Branch Cut Into a Header



Branch-Abutting Header

**Figure 23
Welding of Branch Connections Joint Design**

Revision Notes

Revision 05 has the following changes:

1. Updated the "Acronyms" section.
2. Clarified the list of the materials to be welded using the procedures in this numbered document. See Item 1 on Page 2.
3. Added the "60 psi" criteria to existing "20% SMYS" criteria in Items 3B, 3D, and 3F on Page 2.
4. Deleted oxyacetylene gas welding from weld procedure selection list in Item 3 on Page 2.
5. Revised Items 3J on Page 3 and 4H on Page 4.
6. Added Item 4K and Table 1 on Page 4.
7. Revised completely Items 5A(2) and 5A(5) on Page 5.
8. Revised Item 7 on Page 6 in several places to clarify language and update requirements.
9. Revised Item 8E on Page 7.

Arc Welding Procedure Requirement All Stress Levels

10. Added Item 8H(6) on Page 7.
11. Revised Item 10 on Page 7.
12. Revised Item 12C(2) on Page 8.
13. Deleted former Items 12C(2)(a) and (b).
14. Revised Item 1 on Page 10.
15. Revised a code number for 0.035", ER70S-6, Lincoln L-56 or equal electrodes in Table 2 on Page 10.
16. Revised an API 5LX material to an API 5L in Table 3 on Page 10.
17. Revised Items 1, 2, 4, and 5 on Page 12.
18. Updated the naming of the weld passes throughout this document.
19. Revised some dimensions in Figures 9, 10, 12, 16, 18, 21, 22, and 23.
20. This document is part of Change 61.