

Establishing Pressure Set Points and Checking for Lock-Up for Regulators and Monitors Using the Long/Short Line Technique

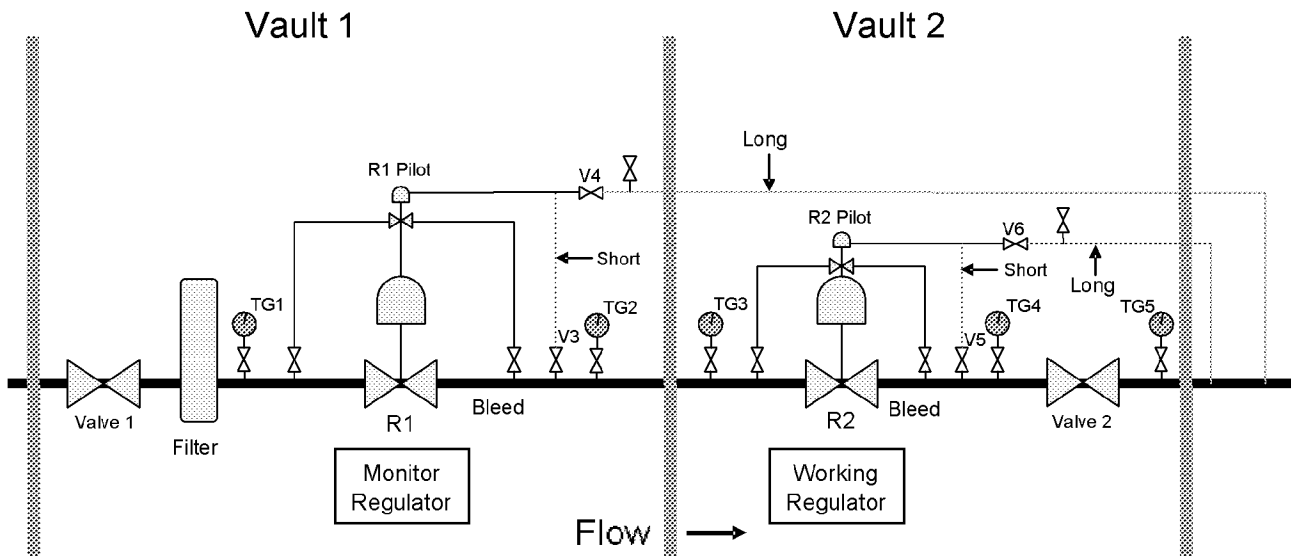

1. Install test gauges (TG1 – TG5).
2. Record as-found regulator set point on TG5.
3. Move regulator sense line to short line.
 - a. Open V5.
 - b. Close V6.
4. Slowly close Valve 2, the downstream valve.
5. Record results of regulator lockup test on TG4. (yes/no).
6. Open Valve 2 to restore flow.
7. Move monitor sense line to short line.
 - a. Open V3.
 - b. Close V4.
8. Record as-found monitor set point on TG2.
9. Slowly close Valve 2, the downstream valve.
10. Record results of monitor lockup test on TG2. (yes/no).
11. Open Valve 2 to restore flow.
12. If necessary, set the monitor pilot (R1 Pilot) to the desired set point.
13. Back out the working regulator pilot (R2 Pilot). (optional)
14. Return monitor sense line to long line.
 - a. Open V4.
 - b. Close V3.
15. If necessary, reset the regulator pilot (R2 Pilot) to station set point.
16. Return regulator sense line to long line.
 - a. Open V6.
 - b. Close V5.
17. Check to ensure that all valves are in normal operating position. Remove the test gauges.