



ARC WELDER QUALIFICATION FOR WORKING ON PIPELINES THAT OPERATE AT OVER 20% OF SMYS

D-30.2

Asset Type: Gas Transmission and Distribution

Function: Design and Construction

Issued by: [REDACTED]

Original Signed By: [REDACTED]

Date: 04-08-09

Rev. #04: This document replaces Revision #03. For a description of the changes, see Page 5.

Purpose and Scope

This numbered document establishes the requirements for arc welding on all grades of pipe and fittings.

Acronyms

API: American Petroleum Institute
 AWS: American Welding Society
 CFR: Code of Federal Regulations
 OD: outside diameter
 psi: pounds per square inch
 SMYS: specified minimum yield strength

References

Document

| | |
|---|----------------|
| Arc Welding Procedure Requirement – All Stress Levels | D-32 |
| Standard of Acceptability for Welding: Nondestructive and Destructive Testing | D-33 |
| Weld Inspection | D-30 |
| Welding of Pipelines and Related Facilities | API 1104 |
| What documents are incorporated by reference partly or wholly in this part? | 49 CFR 192.7 |
| Qualification of welders | 49 CFR 192.227 |

General Information

1. A welder qualified under this numbered document may perform arc welding on all grades of pipe and fittings up to and including X-70. This would include all natural gas lines designed to operate at stress levels of 20% or more of the SMYS to comply with the latest edition of 49 CFR 192.227.
2. The gas standard definitions contained in the latest edition of API 1104 and in the edition referenced in latest 49 CFR 192.7 shall apply to this numbered document.

Qualification Test

3. The qualification test administrator may terminate a qualification test at any point when it becomes apparent that a welder lacks the skill necessary to produce satisfactory results.
4. Welders may use a grinder during a qualification test only to grind the root pass before applying the hot pass (second pass), to feather starts and stops, or to clean and remove occasional minor undercut, porosity, or slag. Grinding shall not be used extensively during the course of a test for removing gross welder-induced defects. Excessive use of a grinder shall be grounds for termination of the test.
5. Welders shall use the same welding technique and proceed with the same speed that was used to qualify the weld procedure.
6. Qualification and requalification tests shall be performed under the supervision of a qualification-test administrator. A qualification-test administrator shall have knowledge and complete comprehension of the applicable PG&E numbered documents, PG&E welding procedure specifications, and sections pertaining to welder qualification in API 1104 and 49 CFR.
7. Before performing any production welding on pipelines or components designed to operate at over 20% of SMYS, welders shall be qualified using an approved procedure. The weld shall meet the visual inspection requirements of Numbered Document D-40, section "Visual Inspection." The weld shall also be qualified by either the radiographic testing requirements of Numbered Document D-31 (for butt welds only), or the destructive testing requirements of

**Arc Welder Qualification for Working on Pipelines
that Operate at Over 20% of SMYS**

Numbered Document D-31. The radiographic testing requirements are located under the "Standard of Acceptability Nondestructive Testing" section. The destructive testing requirements are located in either the "Standards of Acceptability – Destructive Testing" or the "Destructive Testing of Welded Joints – Branch Welds" section.

- A. The following tests can be performed on steel pipe of any grade; however, the qualification test described below is based on using API 5L Grade B pipe.
- (1) **Butt Weld** - The welder shall make a butt weld on 12-3/4" OD x 0.375" wall thickness pipe in the fixed position with the axis of the pipe either in the horizontal plane or inclined from the horizontal plane at an angle not exceeding 45" (see Figure 1 on Page 3). The 6010 butt-weld test shall not exceed 2 hours and the 7018 butt-weld test shall not exceed 3 hours.
 - (2) **Branch Connection for Full Qualification** – The welder shall lay out, cut, fit, and weld a full-size branch connection on 12-3/4" OD pipe. The weld shall be made with the run-pipe axis in the horizontal position and the branch-pipe axis extending vertically downward from the run (see Figure 2 on Page 4). The 6010 branch-connection test shall not exceed 6 hours and the 7018 branch-connection test shall not exceed 7 hours.

B. Scope of Qualification

- (1) **Full Qualification** - A welder who has successfully completed the 12-3/4" OD butt-weld qualification test described in Item 7A(1) and a full size 12-3/4" OD branch-connection weld described in Item 7A(2) shall be qualified to weld on natural gas pipelines in all positions, on all wall thicknesses, joint designs (including fillet welds), and fittings, and on all pipe diameters and all grades of pipe if the essential variables in Item 8 remain unchanged.
- (2) A welder whose qualification is based on nondestructive testing may not weld on compressor-station pipe or components.
- (3) Note that when welding with low-hydrogen electrodes, the essential variables listed in Item 8 are changed from those used in the qualification procedure described in Item 7A. Welders must be requalified using the new procedure before making these welds.

Requalification

8. If any of the following essential variables are changed, the welder must be requalified using the new procedure.
- A. A change from one welding process to any other welding process or combination of welding processes.
 - B. A change in the direction of welding from vertical up to vertical down or vice versa. (The direction of welding shall be only as allowed by Numbered Document D-22.)
 - C. A change in filler metal classification from Group 1 or 2 to Group 3, or from Group 3 to Group 1 or 2. (See Table 1 below.)

Table 1 Filler Metal Classification Groups

| Group | AWS Specification | Electrode |
|-------|-------------------|---------------------|
| 1 | A5.1 | E6010, E6011 |
| | A5.5 | E7010, E7011 |
| 2 | A5.5 | E8010, E8011, E8011 |
| 3 | A5.1 | E7015, E7016, E7018 |
| | A5.5 | E8015, E8016, E8018 |

9. Requalifying Arc Welders

- A. Welders shall be requalified no later than the last day of the sixth calendar month following the calendar month in which the last previous test was satisfactorily passed. Requalification may consist of successfully passing a radiographic examination of a production butt weld, or by repeating the butt-weld test in Item 7. If the sixth month expires before requalification, the welder must pass the full qualification test again (Item 7).
- B. A requalification test using the destructive method of testing as described in Item 7 may also be required if there is reason to question the welder's ability.

Arc Welder Qualification for Working on Pipelines that Operate at Over 20% of SMYS

Retests

10. If, in the opinion of the qualification-test administrator, a welder fails to pass the qualification or requalification test because of an unavoidable condition or conditions beyond his/her control, the welder may be given a second opportunity to qualify by repeating the test(s) required for qualification or requalification. No further retests shall be given until the welder gets further training or has more practice.
11. Welders who fail the qualification test as described in Item 7, or the requalification test as described in Item 9, and who do not meet the conditions described in Item 10, must:
 - A. Undergo further training or practice before retesting. The extent of training or practice required shall be determined by the qualification-test administrator.
 - B. Pass both the "butt-weld" test and the "branch-connection" test outlined in Item 7 in order to be qualified, or requalified if previously qualified.

Records

12. Records for all welders who have been qualified under this numbered document shall be retained as outlined below:
 - A. All "Employee Qualification and Requalification" records must be retained for a minimum of 5 years.
 - B. All "Employee Qualification and Requalification" records must be retained even through temporary lapses in a welder's qualification.
 - C. The "Employee Qualification and Requalification" record shall be documented by filling out Form FD-90.2.A, "Arc Welder Qualification Test for Piping Systems Operating at Hoop Stresses of 20% or More of the Specified Minimum Yield Strength."

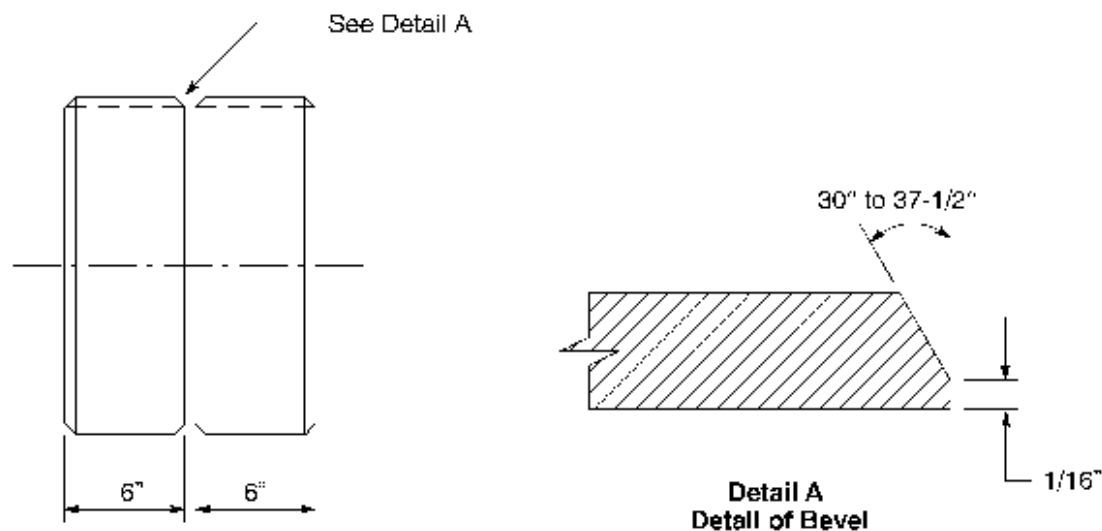

Figure 1
Butt-Weld Test Spools

Butt-Weld Test Spools Notes

1. Welders can use spools to qualify for both cellulose-coated and low-hydrogen electrodes, as documented in Numbered Document D-22.
2. Refer to Numbered Document D-31, for the type, number, and location(s) of butt-weld test specimens.
3. Welds must meet the visual testing requirements of Numbered Document D-40, and either the radiographic testing requirements or the destructive testing requirements of Numbered Document D-31.

**Arc Welder Qualification for Working on Pipelines
that Operate at Over 20% of SMYS**

Ordering Instructions

Specify: Spool, test, 12-3/4" OD, 0.375" wall thickness, API 5L Grade B, 6' length with 30° through 37.5° bevel at both ends. Numbered Document D-30.2, Code 022583.

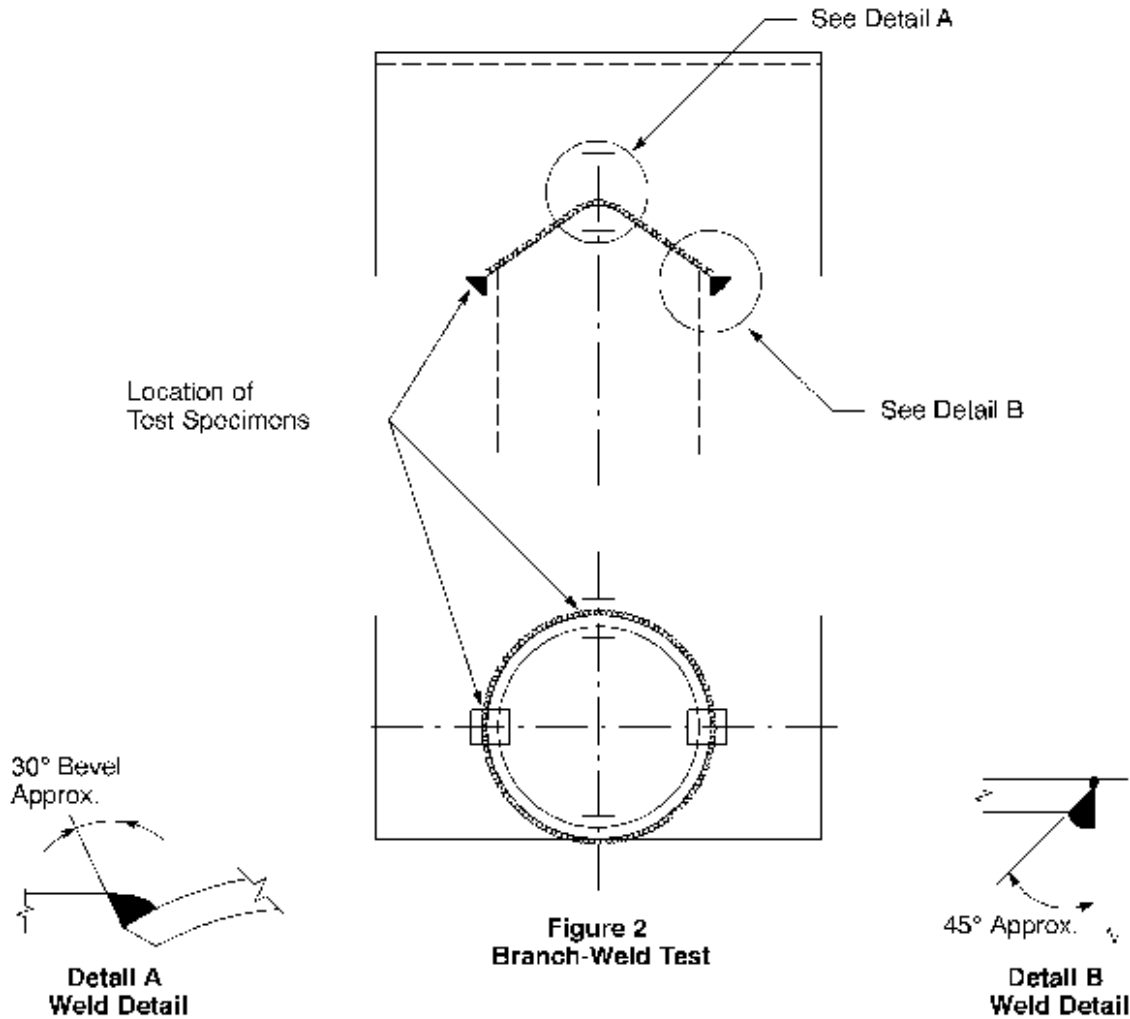

Branch-Weld Test Notes

1. Tests for welding a branch connection for full qualification.
 - A. The pipe is 12-3/4" OD x 0.375" wall thickness, API 5L Grade B.
 - B. The welder must lay out, cut, fit, and weld a branch-fitting connection. A full hole is to be cut in the run.
 - C. The weld is to be made with the run-pipe axis fixed in the horizontal position and the branch-pipe axis extending vertically downward from the run.
 - D. The weld must meet the visual testing requirements of Numbered Document D-40, Section 4, and the destructive testing requirements of Numbered Document D-31.
 - E. Four nick-break specimens are required from the locations indicated. Specimens shall meet the requirements of Numbered Document D-31.
2. Tests for welding a branch connection for limited qualification.
 - A. The pipe is 6-5/8" OD x 0.280" wall thickness, API 5L Grade B.
 - B. Follow the directions as described in Items 1B through 1E above.

**Arc Welder Qualification for Working on Pipelines
that Operate at Over 20% of SMYS**

Revision Notes

Revision 04 has the following changes:

1. Updated the "References" section.
2. Added the hyperlinks in Items 1 and 2 of the "General Information" section on Page 1, and in Item 12C in the "Records" section on Page 3.
3. Revised Figure 2 on Page 4.
4. This document is part of Change 61.