

Prepared by: [REDACTED]



STANDARD OF ACCEPTABILITY FOR WELDING: NONDESTRUCTIVE AND DESTRUCTIVE TESTING

D-31

Asset Type: Gas Transmission and Distribution

Function: Construction

Issued by: [REDACTED]

Original Signed By [REDACTED]

Date: 04-29-09

Rev. #01: This document replaces Revision #00. For a description of the changes, see Page 13.

Purpose and Scope

This numbered document establishes the limits of acceptability for nondestructive inspection (except for visual inspection) of production welding, and for destructive and nondestructive testing for welders. It also provides procedures for preparing test specimens for destructive and specimen testing.

References

Document

<u>Arc Welding Procedure Requirement – All Stress Levels</u>	<u>D-22</u>
<u>Welder Qualification for Under 20% of SMYS</u>	<u>D-30</u>
<u>Arc Welder Qualification for Working on Pipelines That Operate at Over 20% of SMYS</u>	<u>D-30.2</u>
<u>Radiographic Procedure: Double-Wall Panoramic Techniques – Butt-Welded Pipe</u>	<u>D-33</u>
<u>Weld Inspection</u>	<u>D-40</u>
<u>Selection of Steel Gas Pipeline Repair Methods</u>	<u>Utility Standard S4134</u>

Standards of Acceptability – Magnetic Particle Inspection

1. Any indication with a maximum dimension of 1/16" or less shall be classified as non-relevant.
2. Relevant linear indications are those in which the length is more than three times the width.
3. Relevant rounded indications are those in which the length is less than, or equal to, three times the width.
4. The following indications shall be considered unacceptable:
 - A. Linear indications, evaluated as crater or star cracks, with a dimension exceeding 5/32" in length.
 - B. Linear indications evaluated as incomplete fusion (IF) and exceeding 1" total length in a continuous 12" length of weld or 8% of the total weld length, whichever is smaller.
 - C. Any other linear indication not evaluated as IF, star, or crater cracks.
 - D. An individual rounded indication with a size exceeding 1/8".
 - E. An individual rounded indication with a size exceeding 25% of the thinner nominal thickness being joined.
 - F. The distribution of scattered pores exceeds the concentration permitted in Figure 19 on Page 12 or Figure 20 on Page 13.
 - G. Cluster porosity exceeding 1/2" in diameter.
 - H. Cluster porosity with a length exceeding 1/2" in any continuous 12" of weld length.

Standards of Acceptability – Nondestructive Testing

5. Introduction
 - A. Use these standards of acceptability to determine the sizes and type of defects located by radiography and other nondestructive test methods, including visual inspection.
 - B. Classify the weld as unacceptable if it contains any defect exceeding the limits outlined in this numbered document.
 - C. The visual inspection requirements of Item 6 on Page 2 apply only to welder qualification test welds. Refer to Numbered Document D-40 for visual inspection requirements for production welding.

Rev. #01: 04-29-09

D-31 Page 1 of 13

Standard of Acceptability for Welding: Nondestructive and Destructive Testing

- D. Do not subject welds which are to be destructively tested to nondestructive testing other than the visual inspection requirements of Item 6.
- E. Outline radiographic procedures as shown in [Numbered Document D-33](#). Radiography is not normally used on lines smaller than 6".
- F. Since radiographic test methods only provide two-dimensional results, the inspector may reject welds which appear to meet the standards of acceptability documented in this numbered document if, in the inspector's opinion, the *depth* of the defect may be detrimental to the strength of the weld.
6. Visual - Welder Qualifications for Test Welds Only (See [Numbered Document D-40](#) for Production Welds)
- Ensure the weld is free of cracks, inadequate penetration (IP), unrepaired burn through (BT) and other defects. The weld must present a neat, professional appearance. External undercut shall not exceed 1/32" depth or 12-1/2% of the pipe wall thickness, whichever is smaller. There shall be no more than 2" of undercutting in any continuous 12" of weld. See Item 14, "Undercutting" on Page 4. Any weld not meeting these requirements shall be failed without further testing.
7. Inadequate Penetration (IP)
- IP occurs when the weld root is not completely filled with weld metal. Types of IP are listed below.
- A. IP of Weld Root
- IP without high-low present occurs when the weld root is not completely filled. See Figure 1 on Page 7. Ensure any individual condition due to this type of IP does not exceed 1". The total length of such a condition in any continuous 12" length of weld shall not exceed 1". If the weld is less than 12" long, then the total length of such a condition shall not exceed 8% of the weld length.
- B. Inadequate Penetration Due to High-Low (IPD)
- High-low is a condition where the pipe and/or fitting surfaces are misaligned. This situation is represented schematically in Figures 2 and 3 on Page 7. High-low is not objectionable provided that the end preparation meets the requirements of [Numbered Document D-22](#) and the root of adjacent pipe and/or fitting joints are completely tied in (bonded) by weld metal (see Figure 3 on Page 7). When one edge of the root is exposed (or unbonded), the length of this condition shall not exceed 2" at individual locations or 3" in any continuous 12" length of weld (see Figure 2 on Page 7).
- C. Internal Concavity (IC)
- IC, as used in this numbered document, means a bead which is properly fused to and completely penetrates the pipe wall thickness along both sides of the bevel, but the center of the bead is less than flush with the inside surface of the pipe wall. IC is associated with a continuously deposited weld bead, and it differs from BT areas which are associated with intermittently deposited weld metal. The magnitude of concavity shall be defined as the perpendicular distance between an axial extension of the pipe wall surface and the lowest weld bead surface point. It is shown schematically in Figure 4 on Page 7.
- IC is allowable provided the density of the radiographic image does not exceed that of the adjacent base metal. If the density exceeds that of the base metal, dimensions of such areas shall not exceed those specified for BT in Items 5 and 5A.
8. Incomplete Fusion (IF)
- A. IF is the lack of bond between beads or between weld metal and base metal. IF at the root of the joint or at the top of the joint between the weld and the base metal (see Figure 5 on Page 7) shall not exceed 1" in length. The total length of such conditions in any 12" length of weld metal shall not exceed 1". If the weld is less than 12" long, then the total length of such conditions shall not exceed 8% of the weld length.
- B. Incomplete Fusion Due to Cold Lap (IFD)
- IFD is a discontinuity between two adjacent weld beads or between a weld bead and the base metal. For the purposes of this numbered document, IFD is a subsurface discontinuity and differs from IF. IFD is depicted schematically in Figure 6 on Page 7. Individual IFD discontinuities shall not exceed 2" in length. The total length of IFD in any continuous 12" length of weld shall not exceed 2".
9. Burn Through (BT)
- BT is that portion of the root pipe bead where excessive penetration has caused the weld puddle to be blown into the pipe.

Standard of Acceptability for Welding: Nondestructive and Destructive Testing

A. For Pipe 2-3/8" Outside Diameter and Larger

Any unrepaired BT shall not exceed 1/4" or the thickness of the pipe wall, whichever is smaller, in any dimension. The sum of the maximum dimensions of separate, unrepaired BT in any continuous 12" length of weld shall not exceed 1/2".

B. For Pipe Less Than 2-3/8" Outside Diameter

No more than one unrepaired BT is acceptable and it shall not exceed 1/4" or the thickness of the pipe wall, whichever is smaller, in any dimension.

C. Radiographs of repaired BTs shall show that these have been properly repaired. BT shall be considered to have been acceptably repaired if the density of the radiographic image of the BT does not exceed that of the adjacent base metal.

10. Slag Inclusions

A slag inclusion is a nonmetallic solid entrapped in weld metal, or between the weld metal and the pipe metal. Elongated slag inclusions (ESI) are usually found at the fusion zone. Isolated slag inclusions are irregularly shaped inclusions and may be located anywhere in the weld. Wagon tracks are parallel ESIs that are approximately the width of the root pass.

A. Elongated Slag Inclusion (ESI)

Wagon Tracks (WT)

(1) For Pipe 2-3/8" Outside Diameter and Larger

Any ESIs shall not exceed 2" in length or 1/16" in width. The total length of ESIs in any continuous 12" length of weld shall not exceed 2". Parallel slag lines shall be considered as separate conditions if the width of either exceeds 1/32". The aggregate length of ESI indications shall not exceed 8% of the weld length.

(2) For Pipe Less Than 2-3/8" Outside Diameter

Individual ESIs shall not exceed 1/16" in width, or three times the nominal wall thickness in length. Parallel slag lines shall be considered as separate conditions if the width of either one of them exceeds 1/32". The aggregate length of ESI indications shall not exceed 8% of the weld length.

B. Isolated Slag Inclusion (ISI)

(1) For Pipe 2-3/8" Outside Diameter and Larger

The maximum width of any ISIs shall not exceed 1/8". The total length of ISIs in any continuous 12" length of the weld shall not exceed 1/2", nor shall there be more than four ISIs of the maximum width of 1/8" in this length. The aggregate length of ISI indications shall not exceed 8% of the weld length.

(2) For Pipe Less Than 2-3/8" Outside Diameter

The maximum width of any ISIs shall not exceed 1/2 the nominal wall thickness and the total length of such inclusions shall not exceed twice the nominal wall thickness. The aggregate length of ISI indications shall not exceed 8% of the weld length.

11. Porosity (P)

Porosity is defined as gas trapped by solidifying weld metal before the gas has a chance to rise to the surface of the molten puddle and escape. Porosity is generally spherical, but may be elongated or irregular in shape.

A. Individual or Scattered Porosity

The maximum dimension of any individual spherical gas pocket shall not exceed 1/8" or 25% of the pipe wall thickness, whichever is less. The maximum distribution of spherical porosity shall not exceed that shown in Figure 19 on Page 12 and Figure 20 on Page 13.

B. Cluster Porosity (CP)

CP, which occurs in the finish pass, shall not exceed an area of 1/2" in diameter with the maximum dimensions of any individual gas pocket within the cluster not to exceed 1/16". The total length of CP in any continuous 12" length of weld shall not exceed 1/2". CP occurring in all other passes shall comply with Item 7A.

**Standard of Acceptability for Welding:
Nondestructive and Destructive Testing**

C. Hollow Bead (HB)

HB is elongated linear porosity occurring in the root pass. The maximum length of this discontinuity shall not exceed 1/2". The total length of HB in any continuous 12" length of weld metal shall not exceed 2", and individual adjacent discontinuity exceeding 1/4" in length shall be separated by at least 2" of sound weld metal. The aggregate length of all HB indications shall not exceed 8% of the weld length.

12. Cracks (C)

Shallow crater cracks or star cracks which are located at the stopping point of weld beads and which are the result of weld metal contraction during solidification are not considered injurious defects unless their length exceeds 5/32". With the exception of these shallow crater cracks, no weld containing cracks, regardless of size or location, shall be acceptable.

13. Accumulation of Discontinuities (AD)

Excluding IP, high-low and undercutting, any AD having a total length of more than 2" in a continuous weld length of 12" or more than 8% of a continuous weld length if the total weld length is less than 12", is unacceptable. Any AD which totals more than 8% of the weld length associated with an entire joint is unacceptable.

14. Undercutting

Undercutting is defined as a groove melted into base metal adjacent to the toe or root of the weld and left unfilled by weld metal. Undercutting can be checked using an X-ray or by visual/mechanical measurements.

Undercutting adjacent to the cover pass (external undercutting or EU) or root pass (internal undercutting or IU) shall be unacceptable when any of the following conditions exists.

- A. The aggregate length of indications of EU or IU in any combination, in any 12" length, exceeds 2".
- B. The aggregate length of EU or IU, in any combination, exceeds 1/6 of the weld length.

Use Table 1 for acceptance standards for undercutting when using visual and mechanical measurements. Table 1 does not apply to acceptance standards for undercutting when using an X-ray.

Table 1 Acceptance Standards for Undercutting Using Visual and Mechanical Measurements

Depth	Length
1/32" or 12-1/2% of the pipe wall thickness, whichever is smaller	Not acceptable
Above 1/64" to 1/32" or 6% to 12-1/2% of the pipe wall thickness, whichever is smaller	2" or 1/6 the length of the weld, whichever is smaller
1/64" or 6% of the pipe wall thickness, whichever is smaller	Acceptable regardless of length

Standards of Acceptability – Destructive Testing

15. Introduction

These standards of acceptability allow a mechanical evaluation of a test weld. Before destructively testing a weld, it must meet visual inspection requirements as outlined in Item 6 on Page 2. Other than these visual requirements, the standards of acceptability for nondestructive testing (see "Standards of Acceptability – Nondestructive Testing" on Page 1) shall not be applied to destructive test specimens.

All test specimens shall be air cooled to ambient temperature before being tested.

16. Tensile Strength of Butt Welds

A. Preparation

The specimens in Figure 12 through Figure 17 on Pages 10 and 11 shall be a minimum of 9" long and approximately 1" wide. They may be machine cut or torch cut. Sides must be smooth and parallel. If necessary, the sides shall be machined.

B. Method

Tensile test specimens shall be ruptured under tensile load. The tensile strength shall be computed by dividing the maximum load at failure by the least cross-sectional area of the specimen, as measured before load is applied.



Standard of Acceptability for Welding: Nondestructive and Destructive Testing

C. Requirements

The tensile strength of the weld, including the fusion zone of each specimen, shall be equal to or greater than the specified minimum tensile strength of the pipe material, but need not be greater than the actual tensile strength of the pipe material. If the specimen breaks outside the weld and fusion zone (i.e., in parent pipe material) and meets the specified minimum tensile strength for the pipe material, the weld is acceptable.

If the specimen breaks in the weld or fusion zone, and the observed strength is equal to or greater than the specified minimum tensile strength of the pipe material (and meets the nick-break test requirements), the weld is acceptable.

If the specimen breaks below the specified minimum tensile strength of the pipe material, the weld shall be set aside and a new test weld made.

17. Nick-Break Test (Butt Welds)

A. Preparation

The specimens, illustrated in Figure 12 through Figure 17 on Pages 10 and 11, shall be a minimum of 9" long and approximately 1" wide. They may be machine cut or torch cut. They shall be notched with a hacksaw on each side at the center of the weld. Each notch shall be approximately 1/8" deep.

Nick-break specimens prepared in this manner from welds made with certain automatic and semi-automatic processes may fail through the pipe instead of the weld. When this occurs, the external reinforcement may be notched to a depth not to exceed 1/16" measured from the original weld surface.

B. Method

Break the specimens by pulling them in a tensile machine or by supporting their ends and striking their centers. The exposed area of the fracture shall be at least 3/4" wide.

C. Requirements

The exposed surface of each specimen shall show complete penetration and fusion, and:

- (1) The greatest dimension of any gas pocket shall not exceed 1/16", and the combined area of gas pockets shall not exceed 2% of the exposed area.
- (2) Slag inclusions shall not be more than 1/32" in depth, 1/8" or 1/2 the nominal wall thickness in length, whichever is shorter. There shall be at least 1/2" of sound weld metal between adjacent inclusions. The dimensions should be measured as shown in Figure 18 on Page 11.

18. Root and Face Bend Test (Butt Welds)

A. Preparation

The specimens, illustrated in Figure 12 through Figure 17 on Pages 10 and 11, shall be at least 9" long by 1" wide and the long edges shall be rounded. They may be machine cut or torch cut. The cover pass and root bead reinforcement shall be ground or machine flush with the surface of the specimen. These surfaces shall be smooth and any scratches which exist shall be light and transverse to the weld.

B. Method

The specimens shall be bent in a guided bend test jig. Each specimen shall be placed on the die with the weld at mid-span. Face bend specimens shall be placed with the face of the weld directed toward the gap and root bend specimens shall be placed with the root of the weld directed toward the gap. The plunger shall be forced into the gap until the curvature of the specimen is approximately U-shaped.

C. Requirements

The bend test shall be considered acceptable if no crack or other defect exceeding 1/8" or 1/2 the nominal wall thickness, whichever is smaller, in any direction is present in the weld or between the weld and the fusion zone after bending. Cracks which originate along the edges of the specimen during testing and which are less than 1/4" measured in any direction shall not be considered unless obvious defects are observed. Each specimen subjected to the bend test shall meet these requirements.

19. Side Bend Test (Butt Welds)

A. Preparation

The specimens, illustrated in Figure 12 through Figure 17 on Pages 10 and 11, shall be at least 9" long by 1/2" wide and the long edges shall be rounded. They shall be machine cut or they may be torch cut to

Standard of Acceptability for Welding: Nondestructive and Destructive Testing

approximately a 3/4" width and then machined or ground to the 1/2" width. The sides shall be smooth and parallel. The cover and root bead reinforcements shall be ground or machine flush with the surfaces of the specimen.

B. Method

The specimens shall be bent in a guided bend test jig. Each specimen shall be placed on the die with the weld at mid-span and with the face of the weld at 90° to the gap. The plunger shall be forced into the gap until the curvature of the specimen is approximately U-shaped.

C. Requirements

Each specimen subjected to the bend test shall meet the face and root bend test requirements.

Destructive Testing of Welded Joints - Branch Welds

20. Preparation

Specimens shall be cut from the joint at the locations shown in [Numbered Document D-30.2](#).

21. Method

Prepare and break the specimens as shown in Figure 8 through Figure 11 on Page 9.

Repair or Removal of Defects (for Production Welds)

22. Each weld that does not meet the Standards of Acceptability documented in this numbered document shall be repaired or removed.

23. For new construction, a weld must be removed if it has a crack that is more than 8% of the weld length. For operating lines, see [Utility Standard S4134](#).

24. Each weld that is repaired must have the defect removed down to sound metal. The segment to be repaired must be preheated if conditions exist which would adversely affect the quality of the weld repair. After repair, the segment of the weld that was repaired must be radiographed or inspected by same means previously used.

25. Repair a crack, or any defect in a previously repaired area, in accordance with written repair procedures that have been qualified under Numbered Documents [D-30](#) or [D-30.2](#). The minimum mechanical properties specified for the welding procedure used to make the original weld must be met when completing of the final weld repair.

Records

26. Inspection and Test Reports for Pipeline Welds

Records providing documentation of the number of welds inspected must be retained for the life of the facility. See [Numbered Document D-40](#).

27. Employee Qualification and Requalification Records

Records for all welders who have been qualified under this numbered document shall be retained as outlined below.

A. Retain all Employee Qualification and Requalification records for a minimum of five years.

B. Retain all Employee Qualification and Requalification records through temporary lapses in a welder's qualification.

The record shall be made by completing the form specified in the numbered document containing the procedure for which the welder is qualified.

Weld Inspectors

28. All weld inspections shall be performed by persons qualified to inspect welds as stated in [Numbered Document D-40](#).

29. Welder qualification or requalification tests shall be performed in the presence of a qualified welding inspector. The inspector shall ensure that these test welds meet the visual inspection requirement of Item 6 on Page 2 and that they are performed in accordance with the welding procedure.

**Standard of Acceptability for Welding:
Nondestructive and Destructive Testing**

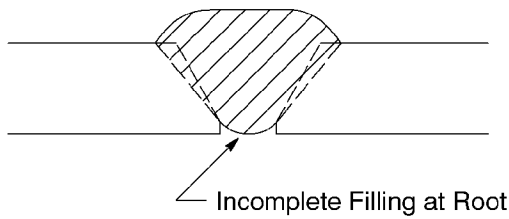

Notes: One or Both Bevels May be Inadequately Filled at Inside Surface, No High-Low at Root

Figure 1
Inadequate Penetration of Weld Groove

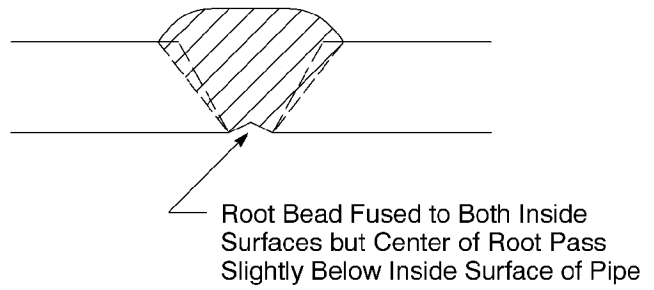
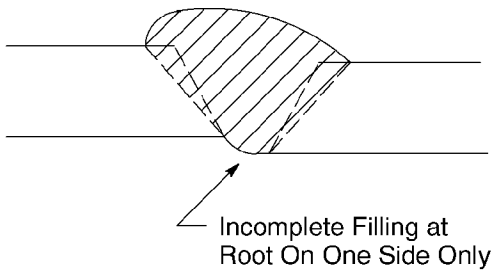

Figure 4
Inadequate Penetration Due to Internal Concavity



Note: High-Low at Root

Figure 2
Inadequate Penetration Due to High-Low

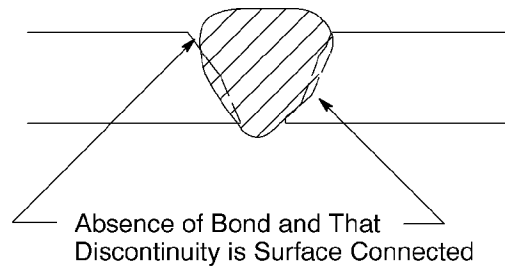

Figure 5
Incomplete Fusion at Root of Bead or Top of the Joint

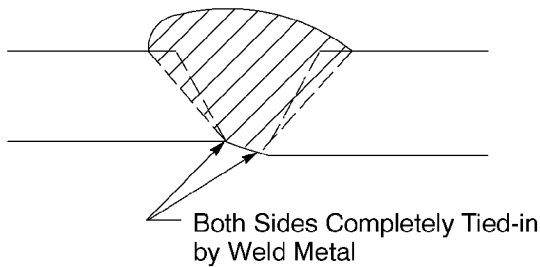
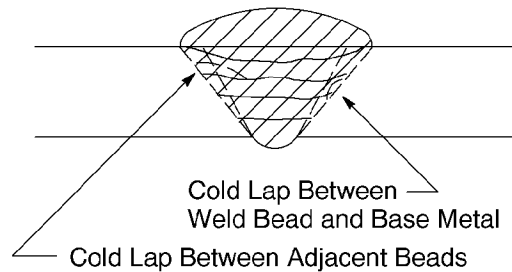

Figure 3
Penetration Adequate With High-Low Present



Note: Cold Lap is Not Surface Connected

Figure 6
Incomplete Fusion Due to Cold Lap



**Standard of Acceptability for Welding:
Nondestructive and Destructive Testing**

Table 2 Type and Number of Test Specimens

Pipe Size in Inches	Tensile ¹	Nick Break	Root Bend	Face Bend	Side Bend	Total
Wall Thickness - 1/2" and Under						
2-3/8 through 4-1/2	0	2	2	0	0	4
Over 4-1/2 through 12-3/4	2	2	2	0	0	6
Over 12-3/4	4	4	2	2	0	12
Wall Thickness - Over 1/2"						
Over 4-1/2 through 12-3/4	2	2	0	0	2	6
Over 12-3/4	4	4	0	0	4	12

¹ Tensile test may be omitted if specimens designated for tensile test are subjected to nick-break test instead.

Note for Figure 7

Pipe Seam - Position the pipe so that the longitudinal pipe seam is not in an area where specimens are required.

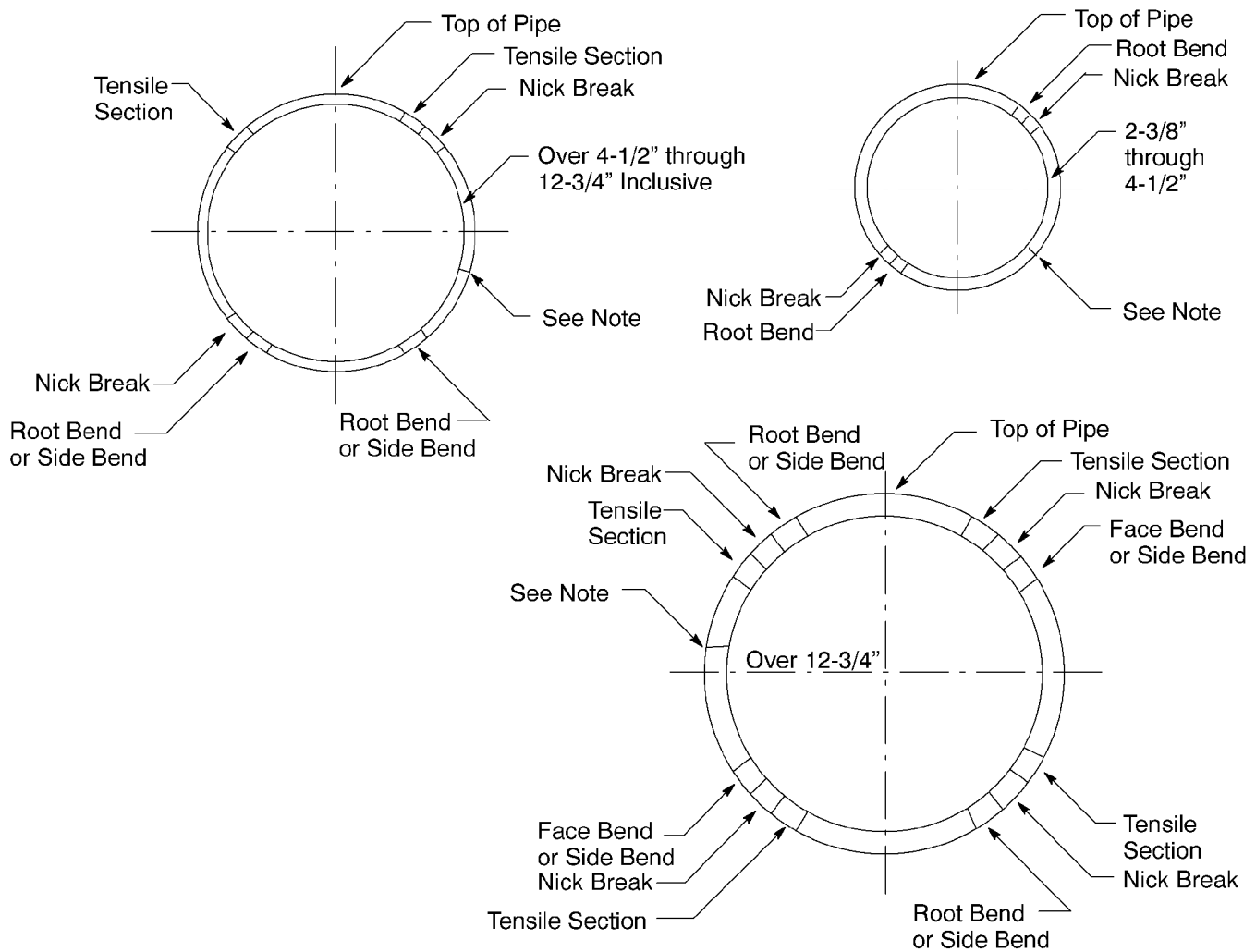

**Figure 7
Location of Butt-Weld Test Specimen**

**Standard of Acceptability for Welding:
Nondestructive and Destructive Testing**

Note for Figure 8 through Figure 11

Nick-break of specimens from the branch-weld test (arc welder qualification for over 20% of SMYS). See Numbered Document D-30.2 for number and location of specimens.

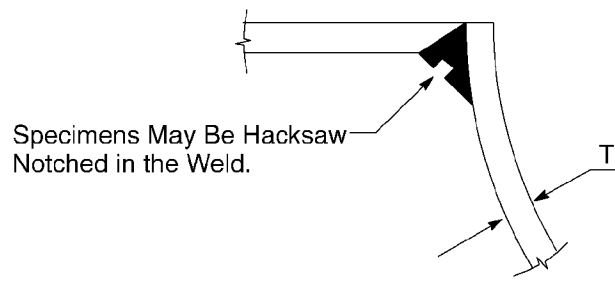

Figure 8
Specimen May Be Hacksaw Notched in the Weld

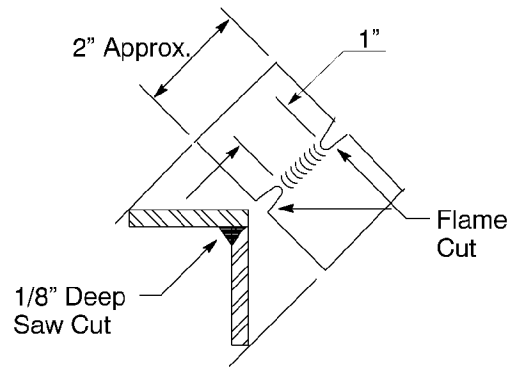
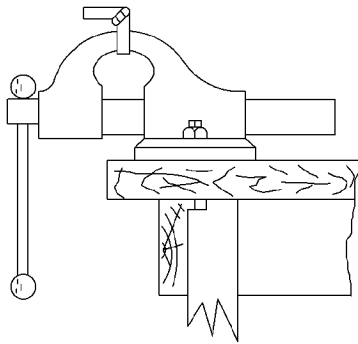
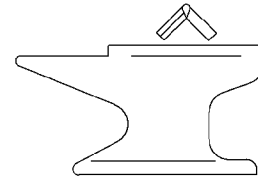

Figure 9
May Be Cut and Nicked With Torch, Do Not Remove Weld Reinforcement



Step 1

Figure 10
Strike With Hammer to Close Saw Cut



Step 2

Figure 11
Strike With Hammer to Break Coupon

**Standard of Acceptability for Welding:
Nondestructive and Destructive Testing**

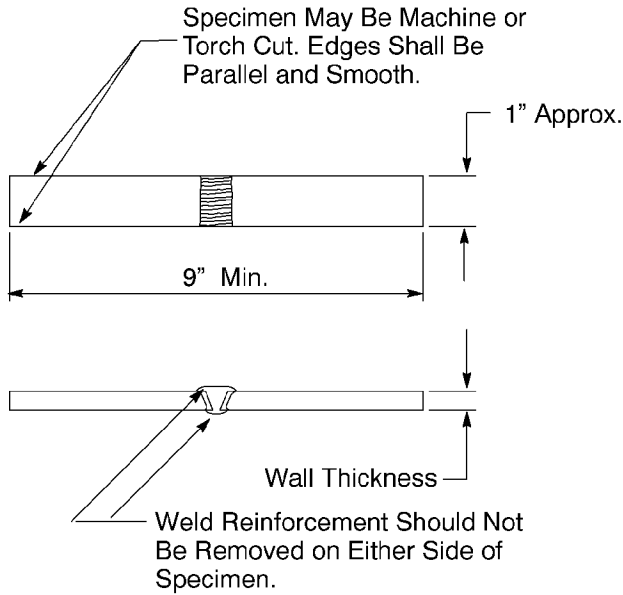

Figure 12
Tensile Test Specimen

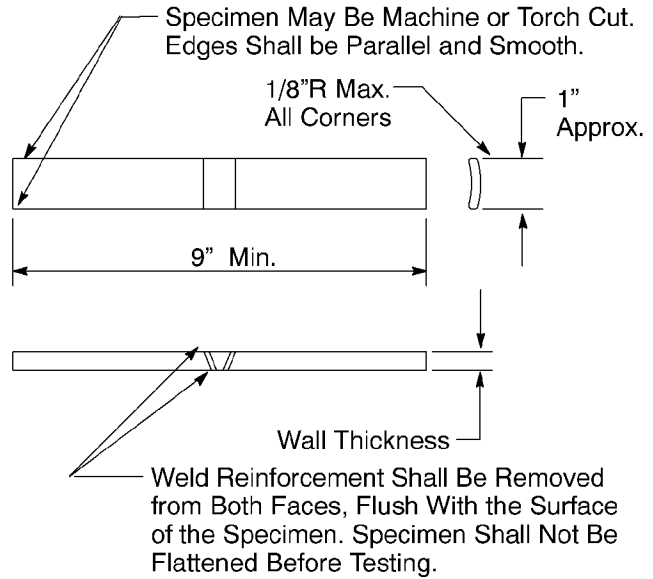

Figure 13
Root Bend and Face Bend Test Specimen

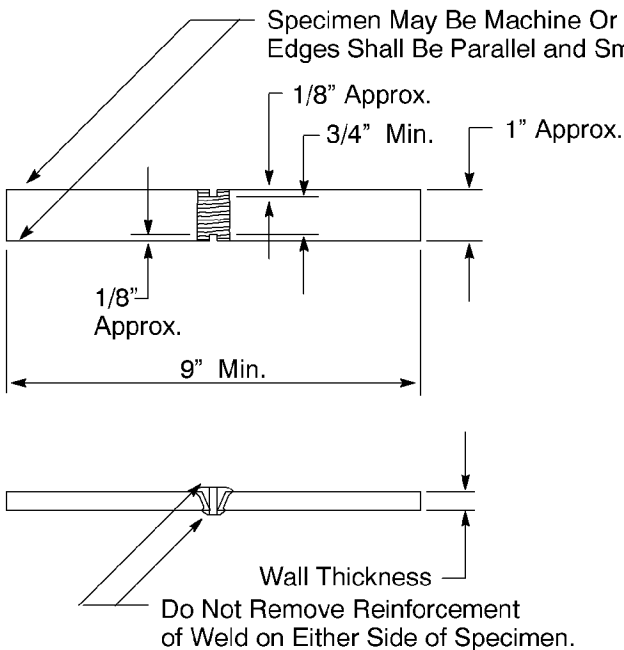

Figure 14
Notch Cut by Hacksaw

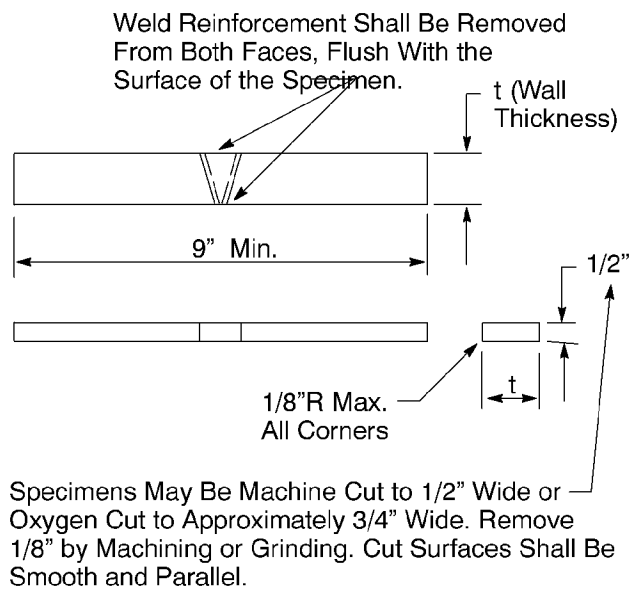
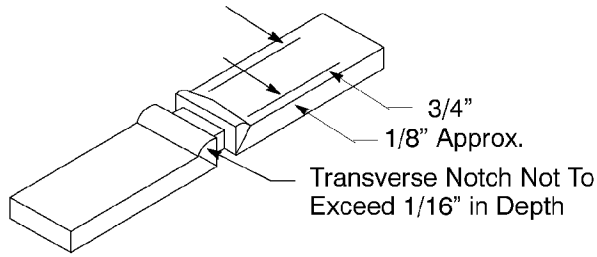

Figure 15
Side Bend Test Specimen

**Standard of Acceptability for Welding:
Nondestructive and Destructive Testing**



Optional Nick Break Test Specimen for Automatic and Semi-Automatic Welding

**Figure 16
Nick Break Test Specimen**

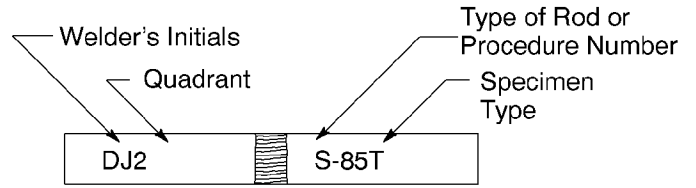

When Sending Specimens to Department of Engineering Research, Identify Samples from a Single Qualification and Bind Together. Fill Out Form No.75-292 and Include With Specimen.

**Figure 17
Identity of Specimen**

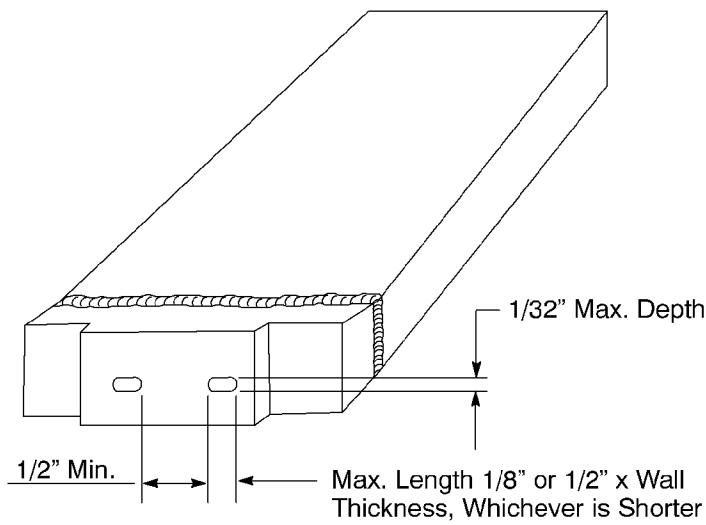

**Figure 18
Evaluation of Slag Inclusions in Weld Nick Break
Has Been Made**

**Standard of Acceptability for Welding:
Nondestructive and Destructive Testing**

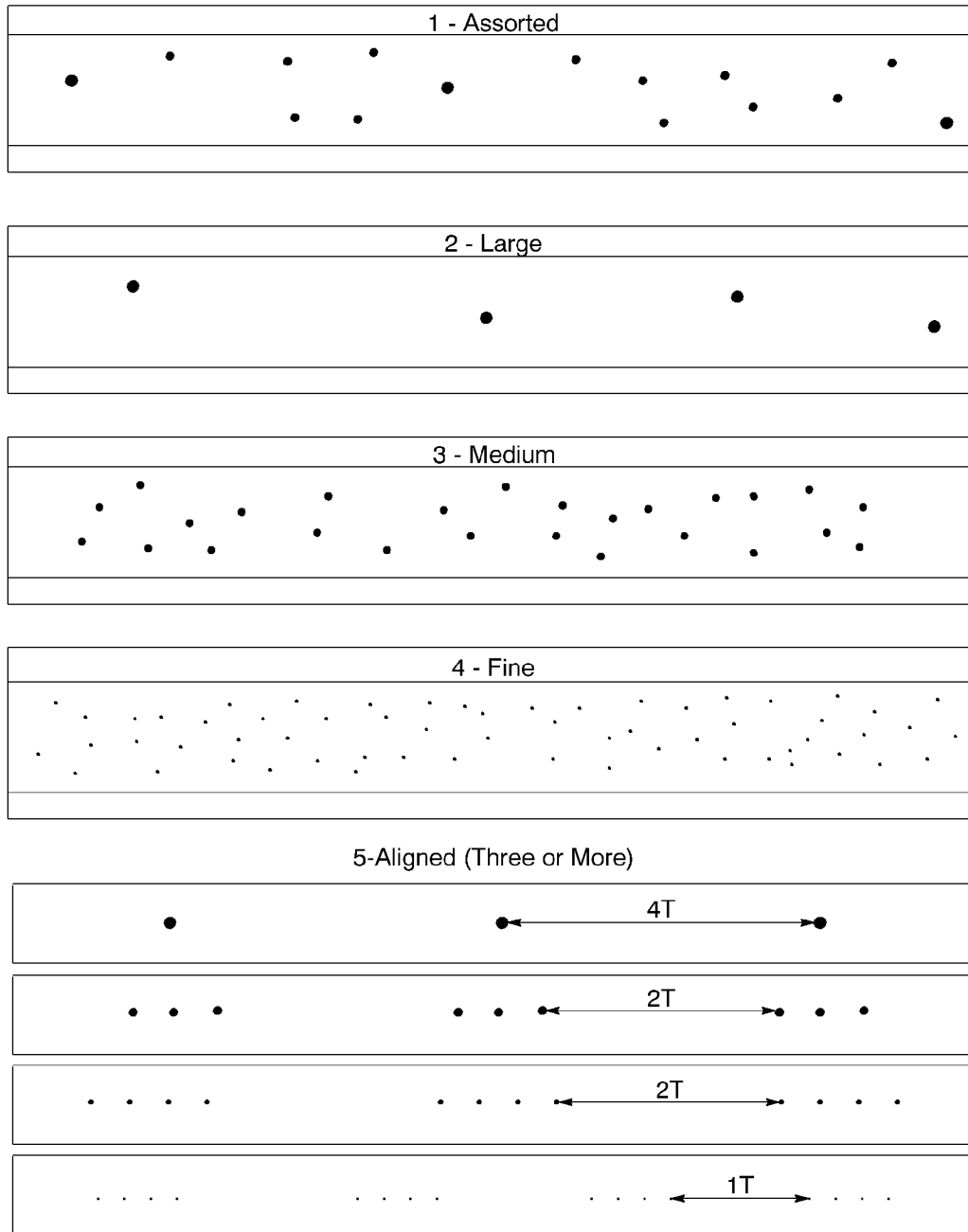
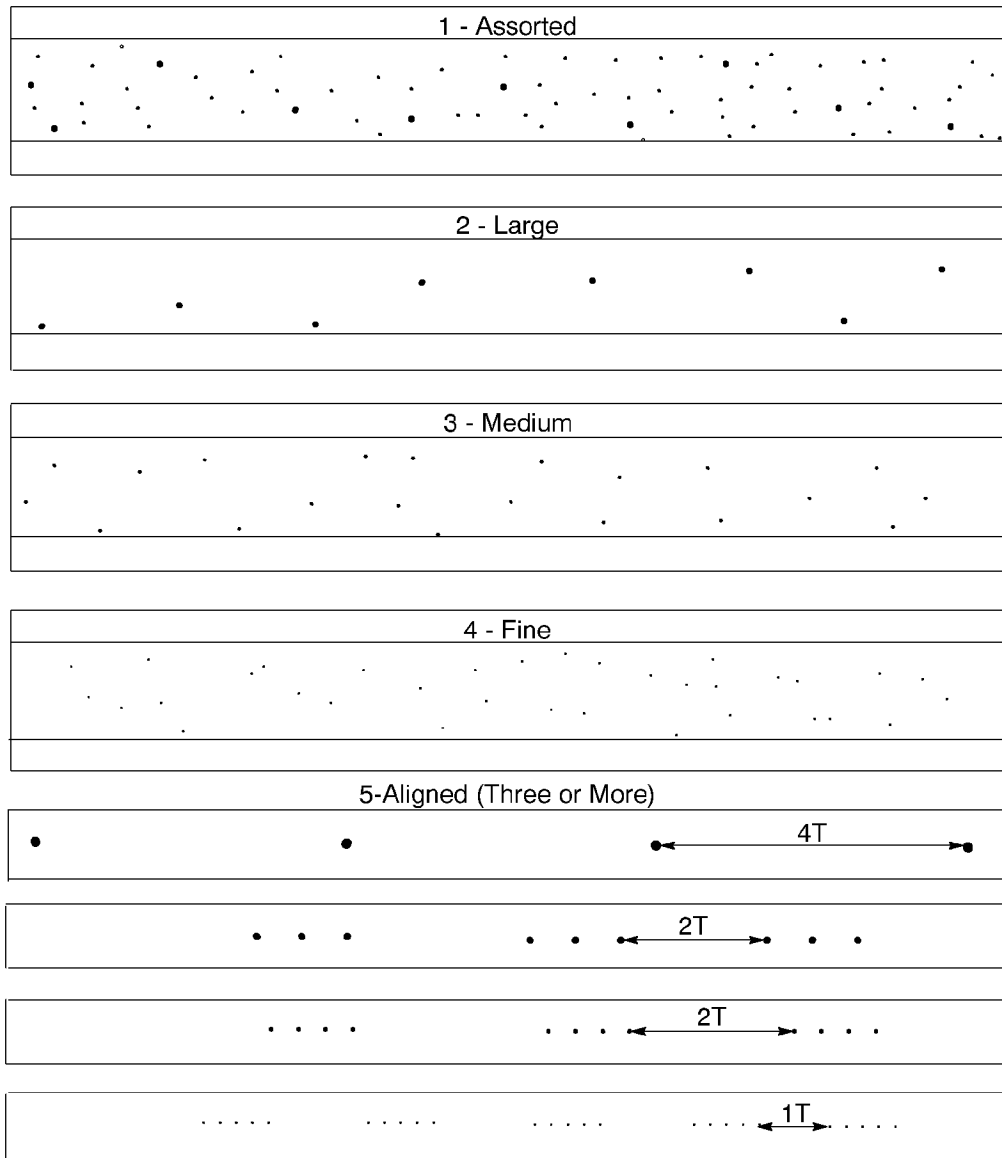

Figure 19
Maximum Distribution of Gas Pockets, Wall Thickness 1/2" or Less

**Standard of Acceptability for Welding:
Nondestructive and Destructive Testing**



T = Pipe Wall Thickness

Figure 20
Maximum Distribution of Gas Pockets Wall Thickness, Over 1/2" to 1-1/4"

Revision Notes

Revision 01 has the following changes:

1. Updated the "References" section.
2. Added the hyperlinks to all references.
3. Added the "Standards of Acceptability – Magnetic Particle Inspection" section.
4. Deleted references to Numbered Document M-26 in Items 18B and 19B on Page 6.
5. Deleted former Item 22A on Page 6.
6. This document is part of Change 61.

