

1. SCOPE

- 1.1 This procedure covers radiographic inspection of weldments in piping 6 inch nominal diameter and larger, and between .156 and 1.25 inch wall thickness using double wall and panoramic techniques, single wall viewing.
- 1.2 This procedure shall be employed when radiographic inspection is specified to comply with Section 192.243 of G.O. 112-C.
- 1.3 It is required that the radiographer shall have at his disposal and understand the contents of this document and API Std. 1104, Section 8.0.
- 1.4 Radiographic inspection shall be performed and interpreted only by qualified personnel who are certified in accordance with the requirements of Section 192.243 of G.O. 112-C.
- 1.5 Radiation Source shall be Iridium 192 and portable X-Ray Units.

2. GENERAL

- 2.1 This procedure shall be used only under the terms and conditions of a valid State of California radioactive materials license.

3. EQUIPMENT

- 3.1 Iridium 192 - Original source intensity shall be approximately one hundred curies. Physical dimensions shall be no greater than 1/8 inch in diameter by 1/8 inch long.
- 3.2 Portable X-Ray Units - Andrex 150 KV, Andrex 160 KV and Andrex 160 KV 360° X-Ray.
- 3.3 Film shall be fine grain of one of the following types or their equivalent: Kodak Type AA, M, T.  
AnSCO
- 3.4 Intensifying screens shall be 0.005 or 0.010 inch thick lead front and back.
- 3.5 Cassettes shall be paper or plastic types. Permacel P 741 black crepe tape shall be used to seal light leaks.
- 3.6 Penetrimeters shall be made of the same material radiographically as the material being welded. Their thickness and identifying numbers shall be as shown on Appendix A.

1	8-2-77	Title Revision & Chg. Par. 1, 3, 1, 4, 6 & 11.1					
CHG.	DATE	DESCRIPTION	APPRD.	CHG.	DATE	DESCRIPTION	APPRD.

APPROVED		<b>PIPING - DATA SHEET</b> <b>RADIOGRAPHIC PROCEDURE DOUBLE WALL</b> <b>PANORAMIC TECHNIQUES BUTT WELDED PIPE</b> <b>GAS STANDARD</b> <b>PACIFIC GAS AND ELECTRIC COMPANY</b> <b>SAN FRANCISCO, CAL.</b>	SUPERSEDES	
BY			SUPERSEDED BY	
DSGN.			SHEET No. 1 of 12 SHEETS	
DR.			DRAWING NUMBER	CHANGE
CH.			085210	/
O.K.				
DATE	SCALE			
2-77	None			

4. LOCATION OF PENETRAMETERS

- 4.1 The radiographic quality shall be evaluated by the image of a properly located penetrameter (See Appendixes B and B-1).
- 4.2 The penetrameter shall be placed on the side nearest the radiation source. Where it is physically impossible to do this, a film side penetrameter shall be placed on the film side of the joint.
- 4.3 The penetrameter thickness shall be based on the single wall thickness.
- 4.4 A lead letter "F" at least 1/2 inch high shall be placed adjacent to the penetrameter whenever a film side penetrameter is used.
- 4.5 A lead letter "S" at least 1/2 inch high shall be placed adjacent to the penetrameter whenever a source side penetrameter is used.
- 4.6 When a complete girth weld is radiographed in a single exposure using a source on the inside of the pipe, three penetrameters equally spaced around the circumference shall be used. When a girth weld is radiographed using a multiple exposure procedure, a penetrameter shall be located within one inch of each end of the applicable limits of film coverage.
- 4.7 If the weld metal is not radiographically similar to the base metal, a penetrameter shall be placed over the weld metal so that it is on an overlaid portion of the film and moved on each successive exposure in order to get full coverage of the weld.
- 4.8 Shims shall be used to produce a total thickness under the penetrameter equal to the nominal thickness of the base metal plus the height of the crown or reinforcement. Shims shall be of a radiographically similar material to the weld metal.

5. FILM QUALITY

- 5.1 All radiographs shall be free from mechanical, chemical or other processing defects that could interfere with proper interpretation of the radiograph such as:
  - a) fogging;
  - b) processing defects such as streaking, watermarks or chemical stains;
  - c) scratches, finger marks, crimps, dirt, static marks, smudges or tears;
  - d) loss of detail due to poor screens or artifacts caused by defective film.

SHEET <u>2</u> OF <u>12</u> SHEETS	DRAWING NUMBER	CHANGE
P. G. and E. CO.	085210	1

6. FILM IDENTIFICATION

- 6.1 Locations markers, the images of which will appear on the film, shall be placed adjacent to the weld on the pipe (not the film) and their locations shall be marked on the pipe surface near the weld in such a manner that it is evident on the film that complete coverage of the weld has been obtained (See Appendix B).
- 6.2 Distance between station numbers or markers is to be spaced so that normal exposure and development will produce a density (E & D) range in accordance with Par. 11.
- 6.3 Maximum acceptable film lengths shall be in accordance with Appendix D.

7. SOURCE TO FILM DISTANCE

- 7.1 Minimum source to film distance for Iridium 192 shall be computed in accordance with Appendixes C and C-1 of this procedure.
- 7.2 The film and source shall be placed against the pipe as shown in Appendix B.

8. TIME OF RADIOGRAPHIC EXAMINATION

- 8.1 Where post weld heat treatment is required, radiography shall be performed after such post weld heat treatment.

9. BACK SCATTER

- 9.1 A lead letter "B", a minimum of 1/2 inch high and 1/16 inch thick, shall be attached to the back of each film holder to insure the use of adequate protection from back scatter. If the letter "B" is discernable on the radiograph, the test is unacceptable.
- 9.2 If back scatter is apparent, a backing lead shall be placed at the back side of the film holder for all exposures. Backing lead thickness shall be 1/16 inch to 1/8 inch.

10. FILM PROCESSING

- 10.1 The developer shall be maintained at a controlled temperature of 68° F. Time adjustment shall be made for temperature changes greater than 2° F. See Manufacturer's recommendation.
- 10.2 No more film should be developed than can be accommodated with at least 1/2 inch separation between hangers.
- 10.3 Solutions shall be stirred prior to the start of processing.

SHEET 3 OF 12 SHEETS	DRAWING NUMBER	085210	DATE
P. G. and E. CO.			

- 10.4 Film shall be agitated during the developing cycle to insure uniformity of developing across the entire surface of the film.
- 10.5 Development time: Manufacturer's recommendations on development time shall be followed.
- 10.6 Stop Bath: After development is complete, the activity of the developer remaining in the emulsion must be halted by an acid bath, or, if this is not feasible, by prolonged rinsing of not less than 15 minutes. The recommendations of the film manufacturer shall be rigorously followed.
- 10.7 Fixing: The hangers shall be agitated vertically for about 10 seconds and again at the end of the first minute, to insure uniform and rapid fixation.
  - 10.7.1 The fixing time shall be three (3) times the clearing time. If the clearing time exceeds four (4) minutes, the solution shall be discarded.
- 10.8 Washing: The washing efficiency decreases rapidly with decreasing temperatures below 60° F. If water temperature is above 68° F., film shall be removed from water as soon as washing is completed, since the gelatin in the film has a natural tendency to soften considerably in warm water.
  - 10.8.1 Washing time shall be 20 to 40 minutes.
  - 10.8.2 Water: There shall be a complete change of water at least once a day.
- 10.9 After washing, film shall be rinsed in a bath of water-spot preventive (wetting agent) such as "Photo Flo" (by Kodak) for approximately 1 minute, to facilitate drainage and to minimize the clinging of water droplets.
- 10.10 Drying: Film should be left on hangers for drying. Drying racks should hold the hanger sufficiently rigid so that film cannot touch one another during drying. Do not dry film on a clothesline outside of the mobile unit.
  - 10.10.1 Drying time shall be adequate to complete drying of film and hangers.

11. FILM DENSITY

- 11.1 Film shall be exposed so that the average H & D density through the thickest portion of the weld metal shall be not less than 1.5 for transparent base film or 0.50 for opaque based film.

39707

SHEET 4 OF 12 SHEETS	DRAWING NUMBER	REVISION
P. G. and E. CO.	085210	1

12. ACCEPTANCE-REJECTION OF DISCONTINUITIES

12.1 Radiographic examination of welded joints shall conform to the Gas Standards and Specifications, Section D-31, Par. 7.0, Standards of Acceptability.

13. REPAIRS

13.1 Welds showing unacceptable discontinuities shall be repaired as provided in the Gas Standards and Specifications, Section D-31.

13.2 All portions of welds which have been repaired shall be re-radiographed using the procedure described herein.

13.3 Repairs shall be identified with letter "R".

14. VIEWING

14.1 Only personnel qualified in the established procedures shall view film for acceptance/rejection, and sign film viewing reports.

14.2 Rejected areas on the film shall be circled in red, initialed by the film viewer, and identified on the film.

14.3 Film Viewing Facilities

14.14.1 Viewing facilities should be so constructed as to provide subdued lighting and exclude background lighting of an intensity which may cause reflections on the radiographic film. Equipment used to view film for radiographic interpretation shall provide a high intensity light source sufficient for the specified density range such that the proper penetrometer and hole for the specified quality level shall be readily visible for the specified density range. The extraneous light from the illuminator shall be masked. The edges of the radiograph shall be masked. If the radiograph contains regions considerably less dense, these areas shall be masked.

15. SAFETY

15.1 Safety regulations shall be followed in accordance with the emergency and operating procedures of the Pacific Gas and Electric Company and the State of California, Department of Public Health.

16. QUALIFICATION OF PROCEDURE

16.1 When it is impracticable to comply with this procedure because of conditions existing which were not anticipated when the

SHEET	5	OF	12	SHEETS	SEARCHED	INDEXED
P. G. and E. CO.					085210	

procedure was specified, a new procedure may be qualified. A copy of the revised procedure shall be forwarded to Gas Construction Department.

17. REPORTING

- 17.1 A record of all procedure qualifications shall be maintained by the Gas Construction Department.
- 17.2 Records of certification for Company personnel performing radiographic examination shall be maintained by the Gas Construction Department with a copy to Department of Engineering Research, Emeryville.

SHEET 6 OF 12	ENGINEERING NUMBER	CHARGE
P. G. and E. CO.	085210	

APPENDIX A

<u>WELD THICKNESS RANGE</u>	<u>SOURCE SIDE</u>		<u>FILM SIDE</u>	
	<u>SOURCE SIDE PENETRAMETER THICKNESS</u>	<u>DESIGNATION ON PENETRAMETER</u>	<u>FILM SIDE PENETRAMETER THICKNESS</u>	<u>PENETRAMETER DESIG- NATION</u>
Up to 1/4 in. incl.	0.005 in.	5	0.005	5
Over 1/4 in. thru 3/8	0.075	7	0.075	7
Over 3/8 thru 1/2	0.010	10	0.010	10
Over 1/2 thru 5/8	0.0125	12	0.010	10
Over 5/8 thru 3/4	0.015	15	0.0125	12
Over 3/4 thru 7/8	0.0175	17	0.015	15
Over 7/8 thru 1	0.020	20	0.0175	17
Over 1 thru 1-1/4	0.025	25	0.020	20
Over 1-1/4 thru 1-1/2	0.030	30	0.025	25
Over 1-1/2 thru 2	0.035	35	0.030	30

SHEET ..... 7 ..... OF ..... 12 ..... SHEETS	DRAWING NUMBER	CHANGE
P. G. and E. CO.	085210	

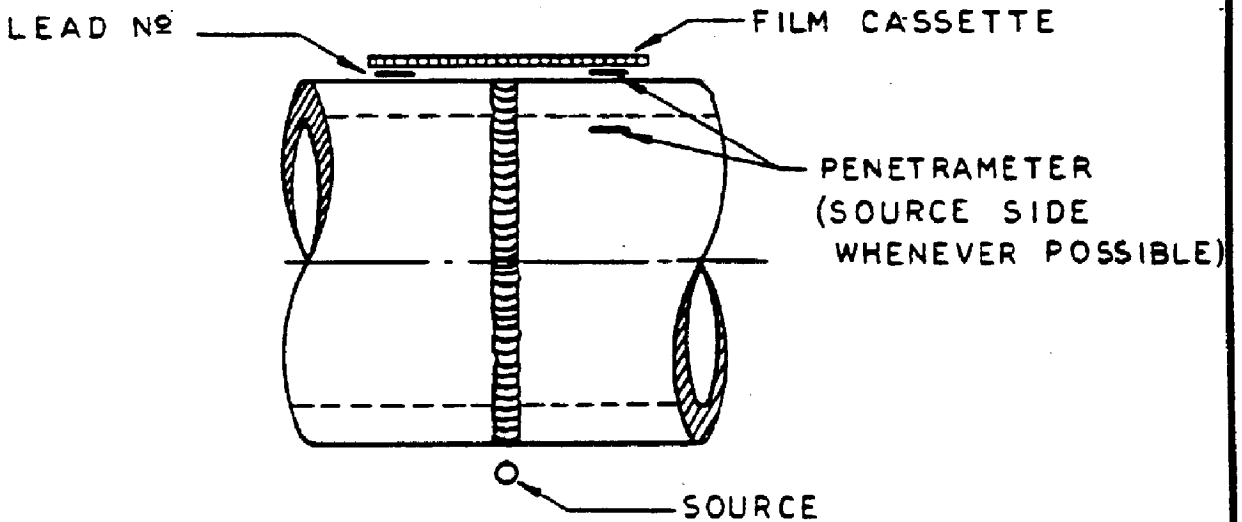
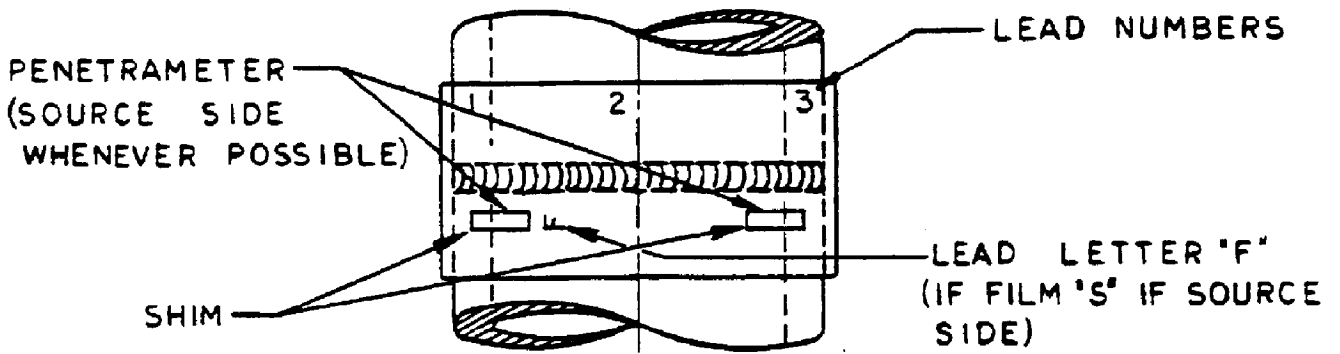
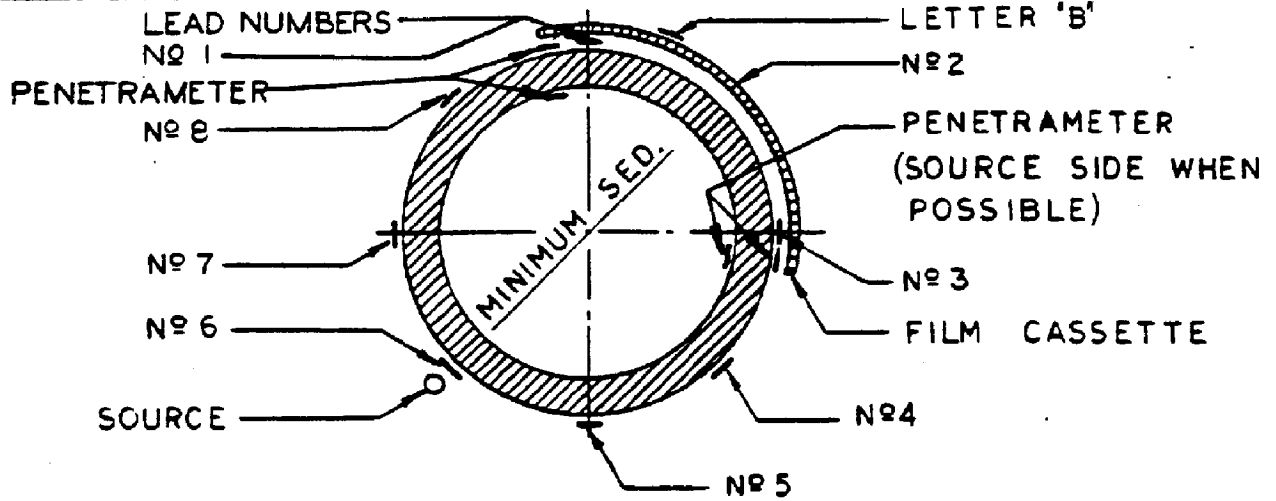

APPROVED BY							
1		9-2-76	TITLE REVISION, REVISED PENETRATOR LOC.				
CHG.	DATE	DESCRIPTION		CH	BY	CH.	APP.
SUPV. BY DSGN. DR. CH. O.K. DATE 2-11-1971 SCALE NONE				DRAWING LIST SUPERSEDED BY SHEET NO. 8 OF 12 SHEETS DRAWING NUMBER 085210 CHANGE /			
PIPING - DETAILS APPENDIX B DOUBLE WALL TECHNIQUE PLACEMENT OF LOCATION MARKERS FILM IDENTIFICATION & SOURCE GAS STANDARD PACIFIC GAS AND ELECTRIC COMPANY SAN FRANCISCO, CALIFORNIA							



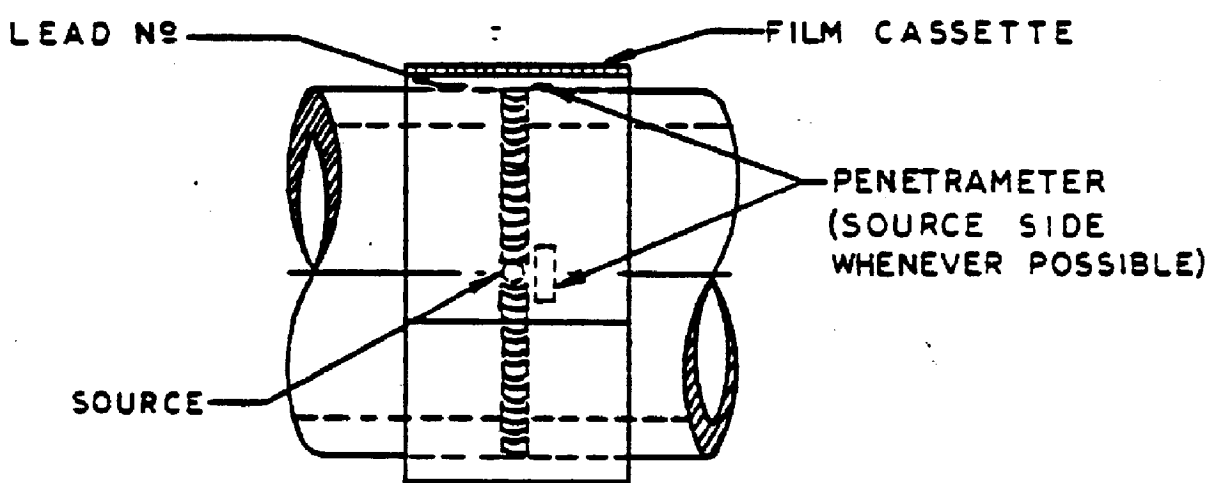
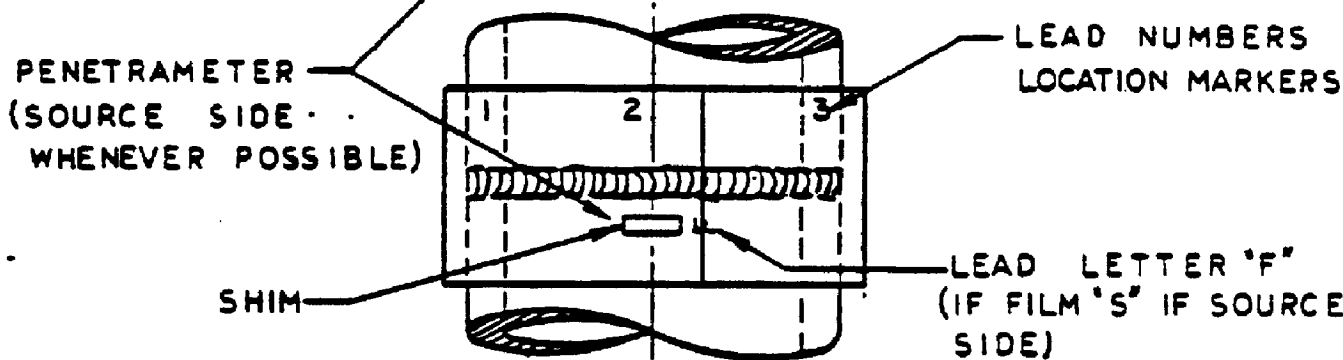
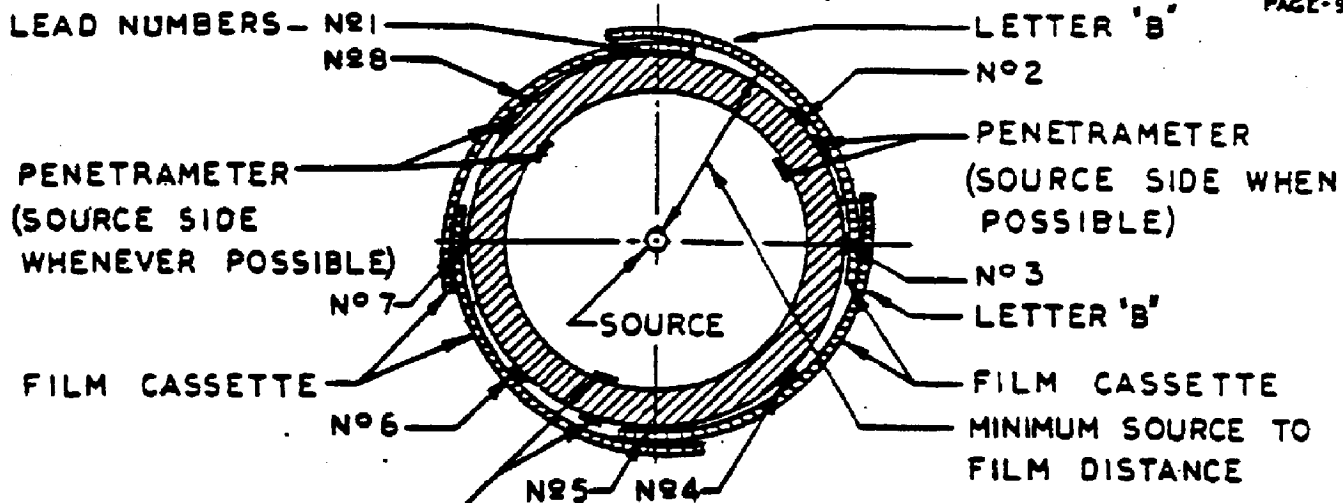

1 9-278 TITLE REVISION

CHG.	DATE	DESCRIPTION	APPROV.	CHG.	DATE	DESCRIPTION	APPROV.

APPROVED

BY

DRGN.

DR.

CH.

O.K.

DATE 2-11-71

SCALE NONE

PIPING - DETAILS  
APPENDIX B-1  
PANORAMIC TECHNIQUE PLACEMENT OF LOCATION  
MARKERS FILM IDENTIFICATION & SOURCE  
GAS STANDARD  
PACIFIC GAS AND ELECTRIC COMPANY

SUPERSEDED

SUPERSEDED BY

SHEET No. 9 of 12 SHEETS

DRAWING NUMBER 085210

SCALE /

SOURCE DIAMETER [INCHES]

$\frac{3}{8}$   $\frac{5}{16}$   $\frac{1}{4}$   $\frac{3}{16}$   $\frac{1}{8}$   $\frac{3}{32}$   $\frac{1}{16}$   $\frac{1}{32}$

MINIMUM SOURCE TO FILM DISTANCE [INCHES]

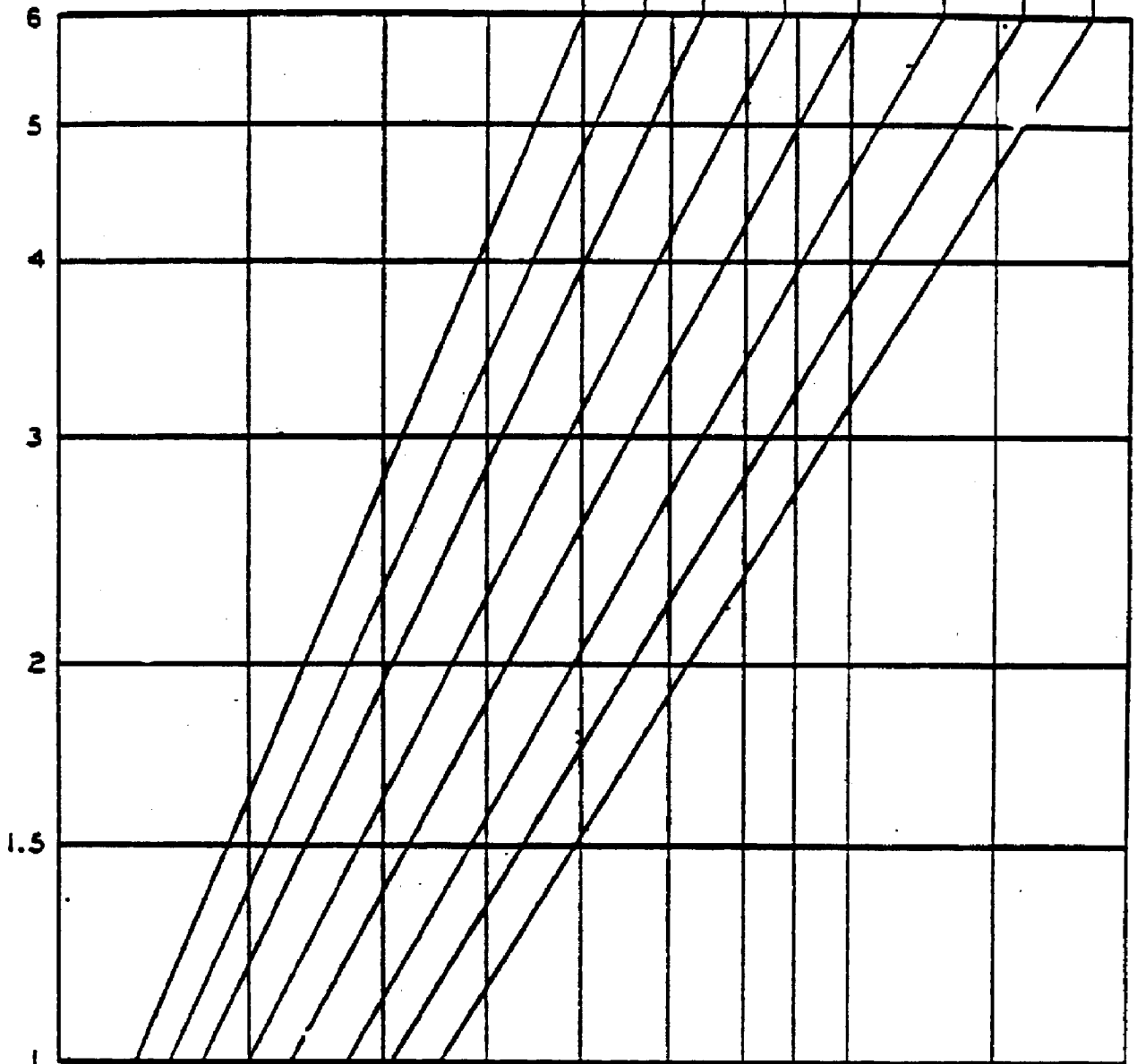

$\frac{1}{3}$   $\frac{1}{4}$   $\frac{3}{8}$   $\frac{1}{2}$   $\frac{5}{8}$   $\frac{3}{4}$   $\frac{7}{8}$  1  $\frac{1}{2}$  2

SPECIMEN THICKNESS [INCHES]

RADIOACTIVE SOURCES WHICH ARE UNCOLLIMATED MUST HAVE MINIMUM SFD CORRECTED BY THE MULTIPLICATION FACTORS SHOWN IN APPENDIX C-1 IF THE SOURCE LENGTH IS GREATER THAN 1/16 INCH. SPECIMEN THICKNESS IS FOR SINGLE WALL.

APPROVED BY							
		1	3-2-76	REVISED TITLE			
		CHG.	DATE	DESCRIPTION	EN	BY	CHK.
SUP. BY DSGN. DR. CH. O.K. DATE 1-21-71		PIPING - DETAILS APPENDIX C SOURCE TO FILM DISTANCE GAS STANDARD PACIFIC GAS AND ELECTRIC COMPANY SAN FRANCISCO, CALIFORNIA			DRAWING LIST SUPERSEDED BY SUPERSEDED BY SHEET NO. 10 of 12 SHEETS DRAWING NUMBER 085210 /		

REQUIRED INCREASE IN SFD  
RATIO FOR SOURCE LENGTH  $\frac{1}{16}$  IN.

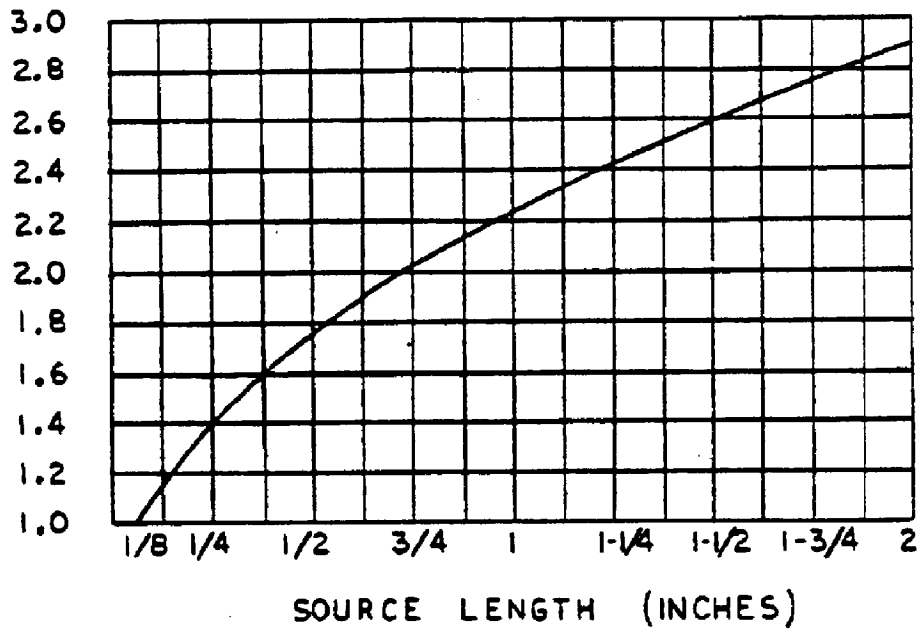

APPROVED BY							
[Redacted]							
1		9-2-76	REVISED TITLE				
	CHG.	DATE	DESCRIPTION		GM	BY	CH. APPR.
SUPY. BY		<p align="center"> <b>PIPING - DETAILS</b>  <b>APPENDIX C-1</b>  <b>SOURCE TO FILM DISTANCE</b>  <b>SOURCE TO LENGTH CORRECTION</b>  <small>GAS STANDARD</small>  <b>PACIFIC GAS AND ELECTRIC COMPANY</b>  <b>SAN FRANCISCO, CALIFORNIA</b> </p>				DRAWING LIST	
DSGN.						SUPERSEDES	
DR.						SUPERSEDED BY	
CH.						SHEET NO. 11 OF 12 SHEETS	
C.K.						DRAWING NUMBER CHANGE	
DATE	SCALE			085210		/	
2-11-1971	NONE						

**APPENDIX D  
Maximum Acceptable Film Lengths**

**PIPE DIAMETER  
(Inches)**

	6 5/8	8 5/8	10 3/4	12 3/4	14	16	18	20	22	24	26	28	30	32	34	36	40	42
7	7.0																	
9	5.8	9.6																
11	4.8	8.0	11.0															
13	4.4	6.7	9.5	13.2														
14	4.2	6.2	8.5	11.6	15.4													
16	4.0	5.8	7.9	10.5	13.6	17.3												
18	3.9	5.6	7.5	9.8	12.5	15.6	19.0											
20	3.8	5.4	7.2	9.3	11.7	14.5	17.6	22.2										
22	3.8	5.2	6.9	8.9	11.1	13.6	16.5	20.0	24.4									
24	3.7	5.1	6.7	8.6	10.8	12.9	15.5	18.5	22.2	26.5								
26	3.7	5.0	6.6	8.3	10.3	12.3	14.8	17.4	20.7	24.2	28.8							
28	3.6	5.0	6.4	8.1	10.0	11.9	14.2	16.7	19.6	22.5	26.2	30.6						
30	3.6	4.9	6.3	7.9	9.7	11.5	13.7	16.0	18.6	21.3	24.5	28.3	32.6					
32	3.5	4.8	6.2	7.8	9.5	11.2	13.3	15.4	17.9	20.3	23.2	26.7	30.2	34.9				
34	3.5	4.8	6.2	7.7	9.3	11.0	13.0	15.0	17.3	19.6	22.3	25.5	28.7	32.2	37.3			
36	3.4	4.7	6.1	7.6	9.1	10.8	12.7	14.6	16.8	19.0	21.5	24.4	27.4	30.7	34.5	39.5		
40								14.1	16.0	18.1	20.3	22.8	25.4	27.8	31.0	35.0	43.8	
42								13.8	15.6	17.7	19.8	22.2	24.6	26.6	29.7	33.1	41.2	45.8
44								13.6	15.3	17.3	19.4	21.7	23.9	26.0	28.6	31.6	39.0	42.8
46								13.4	15.2	17.0	19.0	21.3	23.4	25.4	27.7	30.4	37.0	40.9
54								12.8	14.1	15.8	17.8	19.8	21.7	23.2	25.4	27.7	32.6	35.0
60													20.6	22.2	24.0	26.0	30.5	32.7
66													19.8	21.4	23.1	24.9	29.0	31.0
72													19.3	20.7	22.3	23.9	27.8	29.7
80													18.7	20.1	21.5	23.1	26.4	28.2

**SOURCE-FILM DISTANCE (Inches)**

P. G. & E. CO. 085210

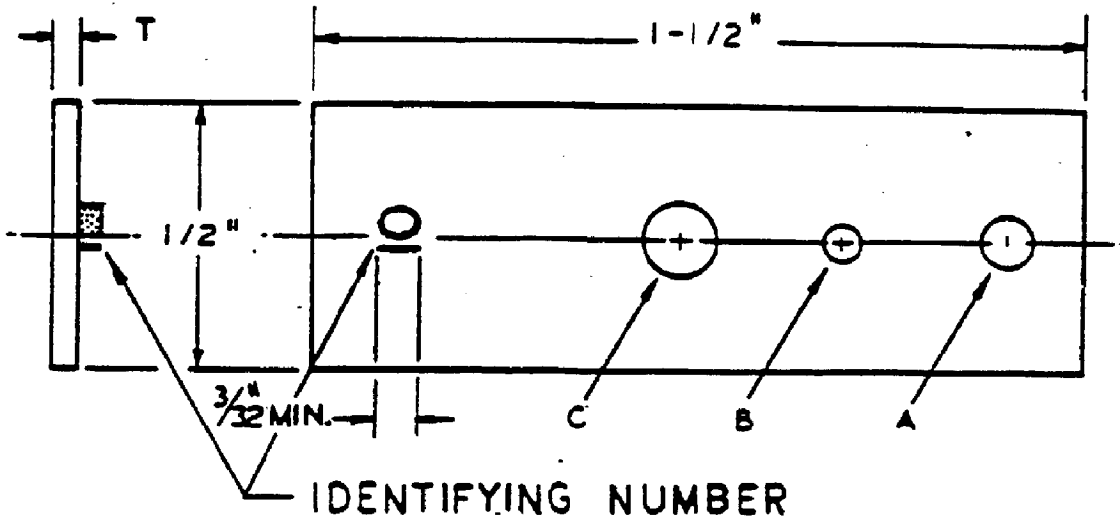

T = PENETRATOR THICKNESS

A DIAMETER = 2 T

B DIAMETER = 1 T

C DIAMETER = 4 T

EXCEPT THAT THE SMALLEST HOLE NEED NOT BE LESS THAN 1/16" IN DIAMETER.

HOLES SHALL BE ROUND AND DRILLED PERPENDICULAR TO THE SURFACE.

HOLES SHALL BE FREE OF BURRS BUT EDGES SHALL NOT BE CHAMFERED.

EACH PENETRATOR SHALL CARRY A LEAD IDENTIFICATION NUMBER.

APPROVED BY								
2		11-19-76	REVISED TITLE, TRANSFERRED FROM STD. D-31.					
1		6-1-70	REVISED TO AGREE WITH PAGE 12 OF 1104 (API)					
CHK.	DATE	DESCRIPTION		CHK.	BY	CHK.		
DRY. IN		<p align="center"><b>PIPING - DATA SHEET</b>  <b>STANDARD PENETRATOR</b>  <b>GAS STANDARD</b>                  PACIFIC GAS AND ELECTRIC COMPANY                  SAN FRANCISCO, CALIFORNIA</p>		DRAWING LIST				
DSGN.				SUPERSEDED 083446 IN 9				
DR.				SUPERSEDED BY				
CH.				SHEET NO.				
G.K.				DRAWING NUMBER		084118		
DATE	SCALE					SHEETS	2	
8-65	None							