

**Attachment 2
Calculation to Determine the Estimated Maximum Strain in a Dent**

1. To determine if a plain dent can be accepted, calculate the estimated maximum strain (as allowed in Table I-C). Contact Pipeline Engineering or System Integrity in GSM&TS for assistance. The strain shall be estimated using data from direct measurement of the deformation contour. Direct measurement techniques may consist of any method capable of describing the depth and shape in terms needed to estimate strain. The strain-estimating techniques may differ, depending on the type of data available. Interpolation or other mathematical techniques may be used to develop surface contour information.
2. Although a method for estimating strain is described below, it is not intended to preclude the use of other strain-estimating techniques.
 - A. R_0 is the initial pipe surface radius, equal to one-half the pipe's nominal outside diameter (OD). Determine the indented OD surface radius of curvature, R_1 , in a transverse plane through the dent. The dent may only partially flatten the pipe such that the curvature of the pipe surface in the transverse plane is in the same direction as the original surface curvature, in which case R_1 is a positive quantity. If the dent is re-entrant (meaning the curvature of the pipe surface in the transverse plane is actually reversed), R_1 is a negative quantity. Determine the radius of curvature, R_2 , in a longitudinal plane through the dent. The term " R_2 " as used here will always be a negative quantity.

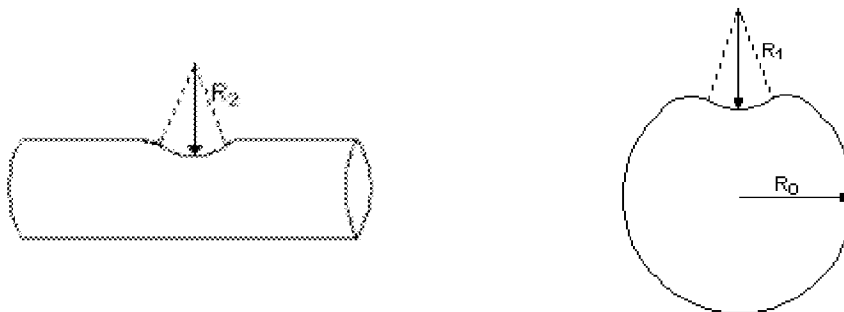

Other dimensional terms are as follows:

- Wall thickness = t
- Dent depth = d
- Dent length = L

Calculate the bending strain in the circumferential direction as:

$$\epsilon_1 = t (1/R_0 - 1/R_1)$$

Calculate the bending strain in the longitudinal direction as:

$$\epsilon_2 = -t/R_2$$

Calculate the extensional strain in the longitudinal direction as:

$$\epsilon_3 = (1/2)(d/L)^2$$

Calculate the strain on the inside pipe surface as:

$$\epsilon_i = [\epsilon_1^2 - \epsilon_1(\epsilon_2 + \epsilon_3) + (\epsilon_2 + \epsilon_3)^2]^{1/2}$$

Calculate the strain on the outside pipe surface as:

$$\epsilon_o = [\epsilon_1^2 + \epsilon_1(-\epsilon_2 + \epsilon_3) + (-\epsilon_2 + \epsilon_3)^2]^{1/2}$$