



OXYACETYLENE WELD PROCEDURE

D-20

Asset Type: Gas Transmission and Distribution

Function: Design and Construction

Issued by: [REDACTED]

Original Signed By: [REDACTED]

Date: 04-06-09

Rev. #01: This document replaces Revision #00. For a description of the changes, see Page 4.

Purpose and Scope

This numbered document complies with 49 CFR Part 192, Subpart E and specifies the requirements for, and defines the limitations of, oxyacetylene welding on gas piping systems operating under 20% of SMYS.

Acronyms

API:	American Petroleum Institute
ASTM:	American Society for Testing and Materials
AWS:	American Welding Society
CFR:	<i>Code of Federal Regulations</i>
psig:	pounds per square inch gauge
SMYS:	specified minimum yield strength
WPS:	Weld Procedure Specification

References**Document**

<u>Steel Butt-Welding Fittings</u>	D-20
<u>Welder Qualification for Under 20% of SMYS</u>	D-20
<u>Welding of Steel in Pipelines</u>	<u>49 CFR 192, Subpart E</u>
<u>Welding of Pipelines and Related Facilities</u>	API 1104

Welding Procedure Specification**1. Materials To Be Welded**

The oxyacetylene welding process is limited to use on the following materials:

- A. Pipe manufactured to API 5L, Grade B or X-42, ASTM A-106-B, and ASTM A-53-B specifications
- B. ASTM-105 forged steel fittings
- C. ASTM A-234 Grade WPB butt weld fittings (Numbered Document D-20)

2. Welding

All welding on pipe and fittings shall be completed using detailed procedural specifications that have been established, qualified, and recorded in accordance with 49 CFR Part 192, API 1104, and the WPS manual.

3. Application

- A. The oxyacetylene welding process may be used on steel gas piping systems designed to operate at a pressure less than or equal to 60 psig within the following limitations:
 - (1) Pipe size 4" diameter and smaller, including butt and sleeve welds, patches, and other repairs.
 - (2) Lateral connection 2" diameter and smaller off header diameter not to exceed 8".
 - (3) Pipe wall thickness maximum 0.188".
 - (4) When cutting or welding near fittings containing rubber stoppers, it is recommended that the minimum distance between the face of the stopper and the cutting or welding operation be as indicated in Table 1 on Page 2.

Oxyacetylene Weld Procedure

Table 1 Minimum Distance Between Stopper and Weld or Cut

Pipe Size (Inches)	Minimum Distance Between Stopper and Weld or Cut ¹ (Inches)
3/4	6
1	6
1-1/4	6
1-1/2	7
2	8
2-1/2	9
3	10
4	12

¹ In those cases where it is not possible to maintain the recommended minimum distance between the stopper face and the cutting or welding operation, some auxiliary cooling means such as wet burlap or wet rags should be placed around the fitting to reduce the temperature.

4. Materials and Equipment

- A. The welding rod type shall meet the requirements of AWS Publication A5.2 Class R60, and shall be approved by gas engineering personnel. Sizes are specified in Table 2 below.
- B. The codes for approved welding rods are 159050 (1/8" x 36" R60) and 150185 (3/32" x 36" R60).
- C. Welding tip size is specified in Table 2 below.
- D. Only approved oxygen and acetylene regulators shall be used.
 - (1) Acetylene shall not be used at a pressure in excess of 15 psig.
 - (2) Oxygen and acetylene regulators for welding should be set to pressures listed in Table 2 below.
- E. All tools and equipment used in welding operations shall be in good operating condition, and shall be of a capacity suited to the work for which they are employed.

Table 2 Materials and Equipment

Joint Design	Pipe Size (Inches)	Welding Tip Orifice Size			Welding Rod Diameter (Inches)	Flame Characteristic	Regulator Pressure (psig)	
		Drill Size	Inches	Victor Tip Size			Oxygen	Acetylene
Butt Welds	3/4 – 2	56 – 53	0.046 – 0.060	2 or 3	3/32 – 1/8	Neutral	3 – 7	3 – 6
	3 – 4	53 – 49	0.060 – 0.073	3 or 4	1/8	Neutral	4 – 10	3 – 7
Fillet Weld	3/4 – 1-1/2	56 – 53	0.046 – 0.060	2 or 3	3/32 – 1/8	Neutral	3 – 7	3 – 6
	2 – 4	53 – 49	0.060 – 0.073	3 or 4	1/8	Neutral	4 – 10	3 – 7

5. Weld Preparation

- A. Before welding, the weld groove and the adjacent surfaces up to 1" around it shall be cleaned and kept free of all dirt, paint, rust, scale, moisture, oil, grease, or other foreign material harmful to welding. Clean by filing, hand or power wire brushing or grinding, and/or by using approved solvents. Alcohol (methanol or ethanol) or acetone are acceptable solvents for cleaning and drying. Do not expose these solvents or their fumes to open flame, arcs, or hot surfaces.
- B. Before sections of pipe and fittings are assembled for welding, all rust, scale, slag, dirt, liquids, or other foreign matter shall be removed from the inside surface of the pipe by swabbing with clean rags or by other acceptable methods. The responsible person (people) on the job shall ensure compliance with this requirement.

Oxyacetylene Weld Procedure

- C. The weld design requirements for end bevels, fillet welds, fitting, joints, and branch connections are specified in Figure 1 through Figure 5 on Pages 3 and 4.
- D. Lineup clamps shall be used on 3" and 4" diameter pipe and is optional on 2" diameter pipe. Maintain 1/8" to 3/16" root gap. Two-inch pipe shall be tack welded at a minimum of two points and welding commenced at a third point. Three- and four-inch pipe shall be tack welded at a minimum of three points and welding commenced at a fourth point.
- E. Adequate working clearance shall be provided around the pipe at all joints to be welded. Flammable materials shall be removed or protected and a fully charged fire extinguisher shall be immediately available at each location where welding or cutting will be conducted.
- F. The welding operation must be protected (shielded) from any weather conditions (rain, snow, ice, or high winds) that would impair the quality of the completed weld.

6. Welding Technique

A. Butt Welds

- (1) Horizontal Welds (butt welds with pipe axis in the vertical position) and Vertical Welds (butt welds with pipe axis in the horizontal position)

- (a) Welds shall be completed by using the forehand process.
- (b) Welds shall be performed using a single pass method.
- (c) Use the joint design as shown in Figure 1 and Figure 2 below.
- (d) The pipe shall be adequately supported and alignment maintained during welding.

B. Fillet Welds

- (1) The bead shape of all fillet welds shall be flat or slightly convex, and the length of each weld leg shall be equal. All attachments using fillet welds shall be made in accordance with Figure 3 through Figure 5 on Page 4.

- (a) Welds shall be completed by using the forehand process, and uphill method only.
- (b) Welds shall be performed using a single pass method.
- (c) The pipe shall be adequately supported and alignment maintained during welding.

7. Stress Relief

Stress relief is not required.

8. Cooling

There shall be no accelerated cooling of weld joints.

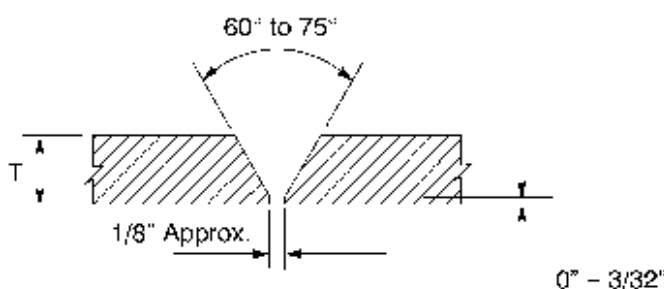

Figure 1
Butt-Weld Joint Design

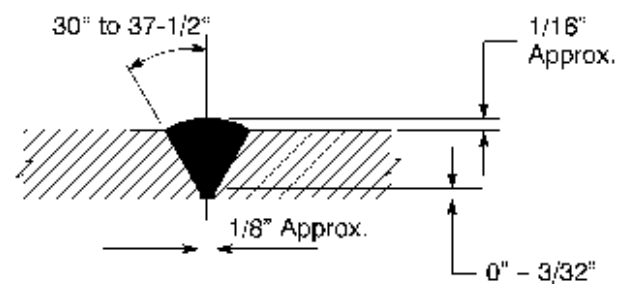

Figure 2
Standard Butt-Weld Design

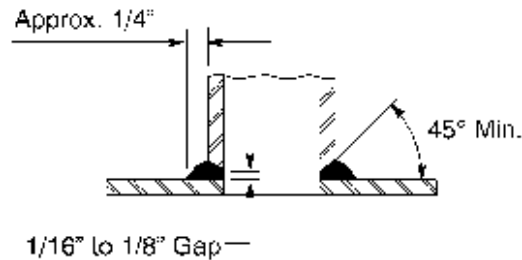
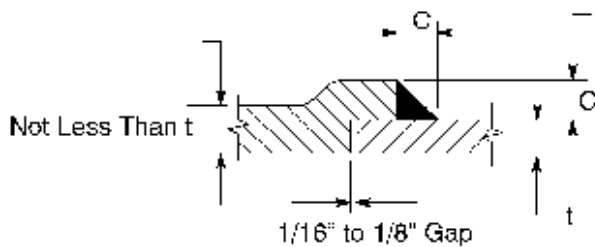

Figure 3
Branch Abutting Header



t = Wall Thickness Nominal

C Minimum = $1-1/4 t$, But Not Less Than $5/32$ "

Figure 4
Socket-Welding Joint

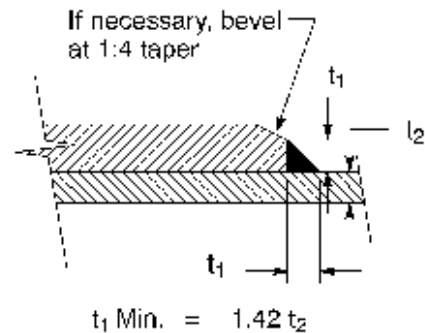

Figure 5
Welding Sleeve Attachments or Patches

Revision Notes

Revision 01 has the following changes:

1. Updated the "Acronyms" and "References" sections.
2. Revised Item 1 on Page 1 in the "Welding Procedure Specification" section.
3. Added WPS manual to Item 2 on Page 1 in the "Welding Procedure Specification" section.
4. Revised the operating pressure limit in Item 3A on Page 1.
5. Added Item 3A(4) on Page 1 and Table 1 on Page 2.
6. Added the "Victor Tip Size" column to Table 2 on Page 2.
7. Deleted the "Pipe Bevel" column from Table 2 on Page 2.
8. Revised regulator pressures for oxygen and acetylene in Table 2 on Page 2.
9. Revised dimensions in Figure 1 and Figure 2 on Page 3, and in Figure 4 and Figure 5 above.
10. This document is part of Change 61.